

# InRow<sup>®</sup> RD

Air-Cooled/Fluid-Cooled — 50/60 Hz



ACRD100, ACRD101,  
ACRD200, ACRD201



ACRD500, ACRD501,  
ACRD502

*Technical Data*

## American Power Conversion Legal Disclaimer

The information presented in this manual is not warranted by the American Power Conversion Corporation to be authoritative, error free, or complete. This publication is not meant to be a substitute for a detailed operational and site specific development plan. Therefore, American Power Conversion Corporation assumes no liability for damages, violations of codes, improper installation, system failures, or any other problems that could arise based on the use of this Publication.

The information contained in this Publication is provided as is and has been prepared solely for the purpose of evaluating data center design and construction. This Publication has been compiled in good faith by American Power Conversion Corporation. However, no representation is made or warranty given, either express or implied, as to the completeness or accuracy of the information this Publication contains.

**IN NO EVENT SHALL AMERICAN POWER CONVERSION CORPORATION BE LIABLE FOR ANY DIRECT, INDIRECT, CONSEQUENTIAL, PUNITIVE, SPECIAL, OR INCIDENTAL DAMAGES (INCLUDING, WITHOUT LIMITATION, DAMAGES FOR LOSS OF BUSINESS, CONTRACT, REVENUE, DATA, INFORMATION, OR BUSINESS INTERRUPTION) RESULTING FROM, ARISING OUT, OR IN CONNECTION WITH THE USE OF, OR INABILITY TO USE THIS PUBLICATION OR THE CONTENT, EVEN IF AMERICAN POWER CONVERSION CORPORATION HAS BEEN EXPRESSLY ADVISED OF THE POSSIBILITY OF SUCH DAMAGES. AMERICAN POWER CONVERSION CORPORATION RESERVES THE RIGHT TO MAKE CHANGES OR UPDATES WITH RESPECT TO OR IN THE CONTENT OF THE PUBLICATION OR THE FORMAT THEREOF AT ANY TIME WITHOUT NOTICE.**

Copyright, intellectual, and all other proprietary rights in the content (including but not limited to software, audio, video, text, and photographs) rests with American Power Conversion Corporation or its licensors. All rights in the content not expressly granted herein are reserved. No rights of any kind are licensed or assigned or shall otherwise pass to persons accessing this information.

This Publication shall not be for resale in whole or in part.





# Contents

---

- Overview ..... 1**
  
- Scalable Solution for Critical Environments ..... 2**
  - InRow Advantages ..... 2
  - Scalable for High Density ..... 2
  - Hot Aisle Containment System ..... 3
  
- Standard Features..... 4**
  - Cabinet ..... 4
  - Shutdown Input/Alarm Output ..... 4
  - Variable Speed Fans ..... 4
  - Counterflow Cooling Coil/Condensate Pan ..... 4
  - Filters ..... 4
  - Selectable Top or Bottom Piping Connections ..... 4
  - Condensate Pump ..... 4
  - Network Management Card ..... 5
  - Bay Kit-InRow RD/NetShelter SX ..... 5
  - Remote Temperature Sensors ..... 5
  
- Optional Features..... 6**
  - Cable Water Detector ..... 6
  - Network Cable ..... 6
  - Filters ..... 6
  - Power Trough ..... 6
  - Data Partition ..... 6
  - Height Adapters ..... 6
  
- Microprocessor Controller ..... 7**
  - Microprocessor Controller ..... 7
  - Open Architecture ..... 7
  - Control Type ..... 7
  - Functions ..... 7
  - Logging ..... 7
  - Display Interface ..... 7
  - Alarms ..... 8

## **InRow RD Models ..... 9**

Exterior components: ACRD100 and ACRD200 series .....	9
Interior components (front): ACRD100 series .....	10
Interior components (rear): ACRD100 series .....	11
Interior components (front): ACRD200 series .....	12
Interior components (rear): ACRD200 series .....	13
Exterior components: ACRD500 series .....	14
Interior components (front): ACRD500 series .....	15
Electrical panel: ACRD100 and ACRD200 series .....	17
Electrical panel: ACRD500 series .....	18
User interface panel: ACRD500 series .....	19

## **Performance Specifications ..... 20**

Net Cooling Capacity (Air and Glycol Cooled) .....	20
Net Cooling Capacity (Water Cooled) .....	21

### **Performance at Percentage of Fan Speed ..... 22**

ACRD100 Series .....	22
ACRD200 Series .....	23
ACRD500 Series .....	24

## **General Data ..... 25**

General Specifications - ACRD200 Series .....	25
Fluid-cooled .....	25
Air-Cooled .....	26
Altitude Correction Factors .....	27
Sound Performance Data .....	27
Electrical Data .....	28

## **Dimensional Data ..... 29**

ACRD100 and ACRD200 series .....	29
ACRD500 series .....	30
NetShelter SX to VX Height Adapter: ACRD100 and ACRD200 series	31
NetShelter SX to VX Height Adapter: ACRD500 series .....	31
NetShelter SX to 48-U SX Height Adapter: ACRD100 and ACRD200 series	31
NetShelter SX to 48-U SX Height Adapter: ACRD500 series .....	31

## **Piping and Mechanical Connections ..... 32**

Refrigeration Piping Diagram (ACRD100 and ACRD500 series) . .	32
Water cooled piping (ACRD200 series) . . . . .	33
Glycol cooled piping (ACRD200 series) . . . . .	34
Top piping and power access locations (ACRD100 series and ACRD200 series)	35
Bottom piping and power access locations (ACRD100 series and ACRD200 series)	36
Top piping and power access locations (ACRD500 series) . . . . .	37
Bottom piping and power access locations (ACRD500 series) . . .	38

## **Outdoor Heat Exchangers ..... 39**

ACCD75201 and ACCD75204 . . . . .	41
ACCD75202 and ACCD75205 . . . . .	41
ACCD75203 and ACCD75206 . . . . .	41
ACCD75207 . . . . .	42
ACCD75208 and ACCD75209 . . . . .	42
ACFC75256 . . . . .	45
Air-cooled Condenser Features . . . . .	45

## **Guide Specifications ..... 46**

<b>Guidelines for Installation . . . . .</b>	<b>53</b>
Room preparation . . . . .	53
Service access . . . . .	53
Receiving the unit . . . . .	53
Rigging . . . . .	53
Condensate drain . . . . .	54

<b>SKU Selection</b>	<b>Width</b>	<b>Voltage</b>	<b>Plug Type</b>
ACRD100	300 mm	208-240V 60 Hz 1 ph	Hard wired
ACRD101	300 mm	220-240V 50 Hz 1 ph	Hard wired
ACRD200	300 mm	208-240V 60 Hz 1 ph	Hard wired
ACRD201	300 mm	220-240V 50 Hz 1 ph	Hard wired
ACRD500	600 mm	200-240V 50/60 Hz 3 ph	Hard wired
ACRD501	600 mm	460-480V 60 Hz 3 ph	Hard wired
ACRD502	600 mm	380-415V 50/60 Hz 3 ph	Hard wired



# Overview

---

The modular, row-based computer room cooling system offers efficient, predictable, and economical cooling for a variety of spaces.

Critical environmental requirements now reach far beyond the confines of the traditional data center or computer room to encompass a larger suite of applications, referred to as technology rooms. Critical environment applications include:

- Computer rooms
- Telecommunication facilities
- Clean rooms
- Power equipment
- Medical equipment rooms
- LAN/WAN environments

A worldwide network of APC representatives is fully qualified to provide engineering, sales, installation, and service for our products.

APC warrants all parts for 12 months from the date of purchase. Extended warranties are available.

## Capacities

InRow RD units are available in two sizes (300mm and 600mm) with nominal capacities ranging from 2-10kW (300mm) and 10-29kW (600mm).

## Room Air Distribution

Row-based systems are placed in line with rack enclosures. At least one system is used per hot aisle. Air is drawn in through the rear of the system, cooled, and discharged into the cold aisle, thereby neutralizing the sensible heating effects of the data processing equipment. The InRow RD delivers high volumes of airflow to eliminate hot spots in densely populated environments.

## Configuration

- Air-cooled
- Fluid-cooled

## Compliance Approval

- UL Listed
- CE
- C-Tick
- C-UL Listed



## Standard Features

### All series:

- Variable-speed fans
- Shutdown input/alarm output
- 2-way/3-way floating point valve
- Top or bottom piping
- Network Management Card (NMC)
- Baying kit-InRow RD to NetShelter® SX rack
- Remote temperature sensor
- Microprocessor controller

### ACRD100 series and ACRD200 series only:

- Insulated cabinet
- Washable filter
- Condensate management with two dual float condensate pumps
- Scroll compressor
- Hot gas bypass

### ACRD100 series only:

- Liquid line solenoid valve

### ACRD500 series only:

- Backward inclined impeller
- Pleated 100-mm (4-in) filter
- NPT to BSPT pipe adapters
- Condensate management with one dual float condensate pump
- Variable speed reciprocating compressor using VFD control
- Pressure equalization solenoid
- Pipe adapters

## Accessories

- Cable leak detector
- Baying kit-InRow RD to NetShelter VX rack
- NetShelter SX 42-U to 48-U height adapters
- NetShelter VX 42-U height adapters
- Bridge trough power cable shield
- Data cable bridge partition
- Isolation ball valves (ACRD100 series only)
- Dry cooler
- Condenser

# Scalable Solution for Critical Environments

---

## InRow Advantages

The row-based solution improves energy efficiency and cooling ability in a number of ways. First, the InRow RD draws air directly from the hot aisle, allowing the InRow RD to take advantage of higher heat transfer efficiency due to higher temperature differences. It can then discharge room-temperature air directly in front of the servers it is cooling. Placing the cooling unit in the row enables the unit to operate at higher return and supply air temperature, yielding 100% sensible capacity. This significantly reduces the need for humidification.

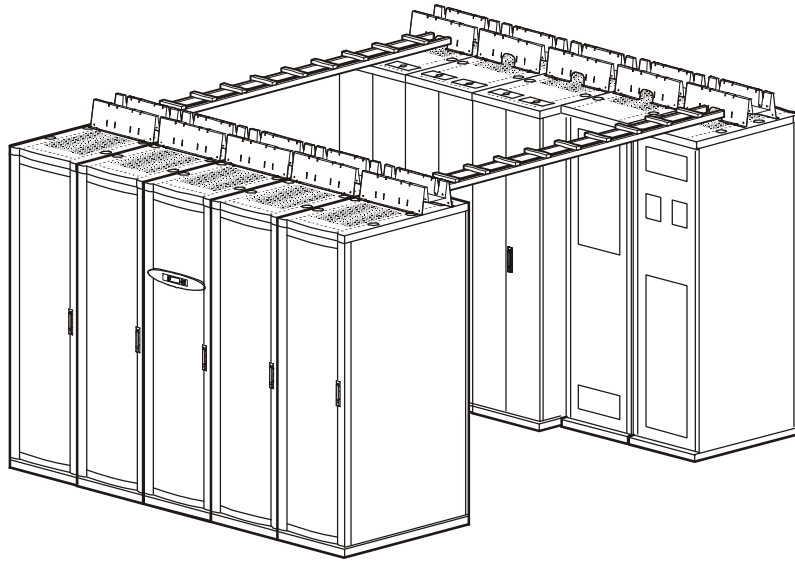

## Scalable for High Density

The predictable performance of the row-based architecture makes it well-suited for high density applications. The focus on heat removal instead of cold air delivery is the key to making this approach scalable. The modular design of the InRow RD allows it to be easily added in the row as the demand for cooling increases.

The additional benefit of the row-based architecture is the ability to add hot aisle containment. Containing the hot aisle further reduces any chance of hot and cold air streams mixing. This provides ultimate predictability and allows the cooling capacity to be matched to the IT heat load.

## Hot Aisle Containment System

Modular ceiling tiles and doors can be used to enclose the hot aisle. This increases the densities that can be handled in a single rack enclosure by eliminating mixing of hot and cold air streams. This method, called load neutralization, removes the heat from the hot aisle, cools it, and then returns it to the surrounding room area at or slightly below room temperature. The warmer return air temperatures that are achieved in this application increase the capacity of the air conditioner.

Use of modular ceiling tiles across a 914.4-mm (3-ft) hot aisle that connects two opposite rack enclosures makes expansion quick and simple. Expansion kits, with the necessary ceiling tile and all baying hardware, can be ordered to increase the size of the hot aisle by one rack on each side. The end doors can be easily removed and re-attached for expansion.

The enclosed hot aisle prevents any warm return air from mixing with cold supply air. In effect, all surrounding room air can act as supply air to the system. The hot aisle containment system is beneficial in any environment. It can be deployed quickly in any controlled space without expensive additions to the infrastructure, such as raised flooring or ductwork.

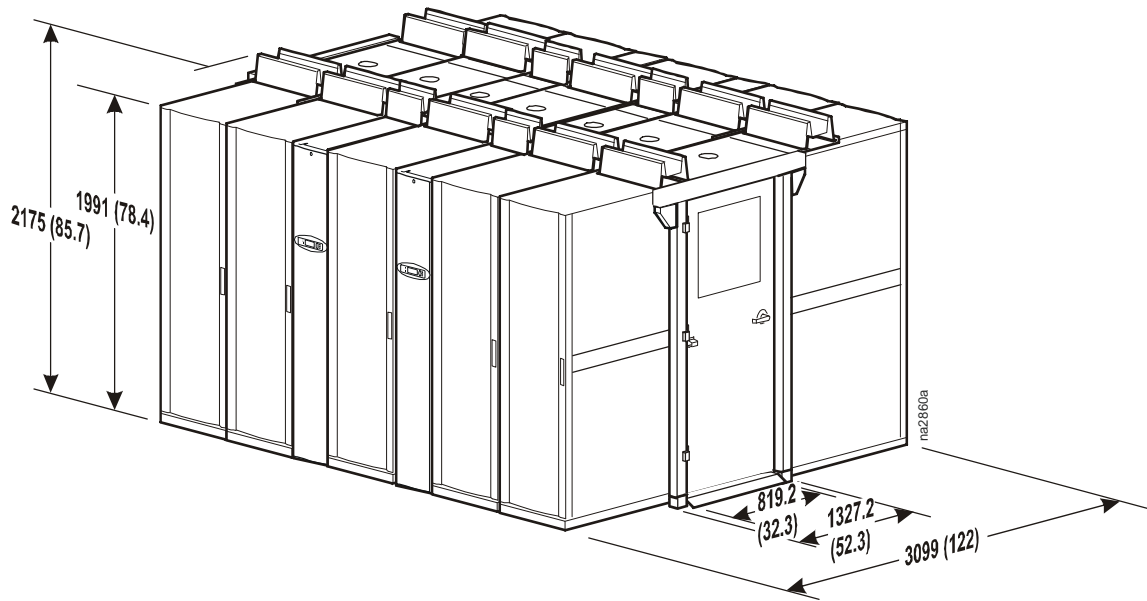

Dimensions are shown in mm (in).

# Standard Features

---

## Cabinet



The frame is constructed of 16 gauge formed steel for maximum strength. The cabinet is serviceable from the front and rear. All exterior panels and corner posts on the frame are powder coated for durability and an attractive finish. The front and rear exterior panels are constructed of 18 gauge perforated steel with 69.5% open free area. All panels, which include a key latch for safety and security, allow easy access and removal. Insulation (ACRD100 and ACRD200 series only) is 80.1 kg/m<sup>3</sup> (5 lb/ft<sup>3</sup>) density and complies with ASTM E84 rating of 25/50.

## Shutdown Input/Alarm Output

The unit provides one field connection input for remote shutdown and one field connection alarm output.

## Variable Speed Fans

Each unit is equipped with variable speed fans to allow for varying heat loads. In order to provide uniform airflow over the cooling coil, the fans provide a draw-through air pattern. The ACRD100 and ACRD200 series units are equipped with six direct drive fan modules. These fans are easily replaceable while the unit is in operation. The ACRD500 series is equipped with two backward inclined, direct drive fans.

## Counterflow Cooling Coil/ Condensate Pan

Designed for high sensible heat ratios, the coil is constructed with copper tubes, raised lance type aluminum fins, and 18 gauge galvanized steel end plates. Coil headers are equipped with anti-drip shields in the event of condensation. The condensate pan is thermal formed non-ferrous material, and is sloped for positive drainage to provide higher indoor air quality.

## Filters

Filtration of conditioned air is extremely vital to maintaining the clean, particle-free environment required by electrical equipment. Filters are easily replaceable from the rear of the unit. The ACRD100 and 200 series systems use greater-than 20% efficiency ASHRAE 52.1, 12.7 mm (1/2 in) washable filters that meet HF-1 standards for electronics (MERV 1 per ASHRAE 52.2). The ACRD500 series system uses a 30% efficient, 102 mm (4 in), deep loading, pleated filter (MERV 8 per ASHRAE 52.2, EN779 G4).

## Selectable Top or Bottom Piping Connections

The unit includes both top and bottom piping connections. All ACRD100 and ACRD500 series connections utilize Roto-Lok fittings for ease of installation and service. The ACRD200 series uses union connectors.

## Condensate Pump

### ACRD100 and ACRD200 series:

Two pumps are factory wired and piped (in parallel) internally to the condensate drain pan. Acting together, the pumps are capable of pumping 9.8 l/hr (2.6 g/hr) against head pressures of up to 50 ft (15.2 m) of total run. Of that run, 16 ft (4.9 m) can be vertical lift as measured from floor level. Dual floats are included with the unit. One float is used for condensate pump control, and the other float generates a condensate pump failure alarm. The InRow RD can be set to either continue running in an alarm condition or shut down to prevent condensate pan overflow.

### ACRD500 series:

The single condensate pump is factory wired and piped internally to the condensate drain pan. The pump is capable of pumping a maximum of 18 m (60 ft) at 32 l/h (8.45 g/hr), which may include a maximum lift of 3.5 m (11.5 ft) as measured from floor level. Dual floats are included with the unit. One float is used for condensate pump control, and the other float generates a condensate pump failure alarm to prevent condensate pan overflow.

## **Network Management Card**

The Network Management Card (NMC) allows communication with the Local Area Network (LAN). In addition, the NMC permits multi-level access to monitoring, control, and event notification features over the building network.

## **Bay Kit-InRow RD/ NetShelter SX**

Baying kits made of 16 gauge steel enable baying the InRow RD to APC NetShelter enclosures.

## **Remote Temperature Sensors**

To control the unit based on rack inlet temperature, remote temperature sensors are provided. The ACRD100 and ACRD200 series units come equipped with one temperature sensor, and the ACRD500 series units come equipped with three. These sensors measure temperature at a point 4m (13ft) from the connection inside the InRow RD unit. These sensors are used for remote placement in the field on an adjacent IT rack.

# Optional Features

---

## Cable Water Detector

A leak detection cable is placed on the floor or subfloor around all possible leak sources. If water or other conductive liquids contact the cable anywhere along its length, the micro-processor controller announces the leak visually, audibly, and across the network. The 6.1-m (20-ft) cable may be cascaded to make custom lengths up to 24.4 m (80 ft).

## Network Cable

Various lengths of network cable are available to ship with your cooling system. The network cable is used to interconnect multiple cooling units in a redundant group, as well as to connect the Network Management Card to your LAN.

## Filters

Electrical equipment requires clean, particle free air, thus making air filtration extremely important. As an optional feature, higher efficiency filters can be purchased for the InRow RD units. The ACRD100 and ACRD200 series units optionally utilize an 50.8mm (2in) pleated, deep loading, 30% ASHRAE 52.1 filter (MERV 8 per ASHRAE 52.2). The ACRD500 series units optionally utilize 102mm (4in) pleated, deep loading, 85% ASHRAE 52.1 filter (MERV 13 per ASHRAE 52.2).

## Power Trough

Overhead power distribution between adjacent NetShelter racks allows for removal of the InRow RD without disrupting overhead power cabling.

## Data Partition

Overhead cable distribution between adjacent NetShelter racks allows for removal of the InRow RD without disrupting overhead cabling.

## Height Adapters

To match the height of the InRow RD to various rack heights, height adapters are available for NetShelter 42-U VX and 48-U SX racks.

# Microprocessor Controller

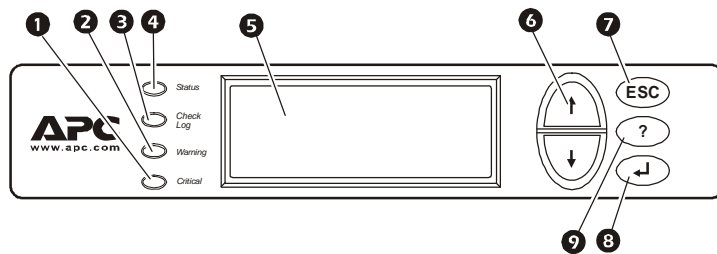

1	Critical Alarm LED
2	Warning Alarm LED
3	Check Log LED
4	Status LED
5	Liquid Crystal Display (LCD)
6	Menu Selection scroll keys
7	Escape key
8	Enter key
9	Help key

## Microprocessor Controller

The microprocessor controller is standard on each unit. The controller provides precision control for the demanding requirements of the following environments:

- Computer rooms
- Telecommunication facilities
- Clean rooms
- Power equipment
- Medical equipment rooms
- LAN/WAN environments

The easy-to-use display interface allows the operator to select options from the menu-driven interface to control and monitor the connected air conditioning system.

## Open Architecture

The InRow RD protocol is open for integration with all building management systems. Communication interface on the system can be Modbus RS485 or Ethernet.

## Control Type

The controller utilizes proportional/integral/derivative (PID), a time-proven precision environmental control method. This allows for custom tuning of control variables to achieve desired system response.

## Functions

- Supply and return air conditions
- Operational mode control
- Event logging
- Alarms
- Redundant group control
- Fan speed adjustment
- Input/output module programming

## Logging

The event log keeps a record of all alarms and events. Each event log contains a time/date stamp as well as operating conditions at the time of occurrence. The controller also displays run time, in hours, for major components (air filters, fans, and condensate pump, as well as humidifier, heater, and compressor for the air-cooled unit).

## Display Interface

The backlit, four-line by twenty-character display interface is password configurable.

## Alarms

The microprocessor controller shall activate a visible and audible alarm in the following occurrences:

### All series:

- Cool Fail
- Air filter clogged
- Return air sensor fault
- Supply air sensor fault
- Rack temperature sensor fault
- High discharge pressure
- Low suction pressure
- Fan fault
- Water detected
- Condensate pump fault
- Air filter run hours violation
- Group communication fault
- Supply air high temperature violation
- Return air high temperature violation
- Filter DP sensor failure
- Suction pressure sensor failure
- Discharge pressure sensor failure
- Persistent high discharge pressure fault
- Rack inlet temperature high violation
- External communication fault
- Internal communication fault
- On standby input contact fault
- A-link isolation relay fault
- Excessive compressor cycling

### ACRD100 series and ACRD200 series only:

- Condensate pan full
- Upper fan power supply fault
- Lower fan power supply fault
- Suction temperature sensor failure
- Persistent low suction pressure fault

### ACRD200 series only:

- Condenser fluid valve actuator fault
- Outdoor heat exchanger (OHE) fault
- Factory configuration not completed
- Liquid refrigerant sensor failure

### ACRD500 series only:

- Compressor drive communication fault
- Compressor drive fault
- Compressor drive warning
- Compressor run hours violation
- Condensate pump run hours violation
- Fan run hours violation
- Supply humidity sensor fault
- High suction pressure



# InRow RD Models

## Exterior components: ACRD100 and ACRD200 series

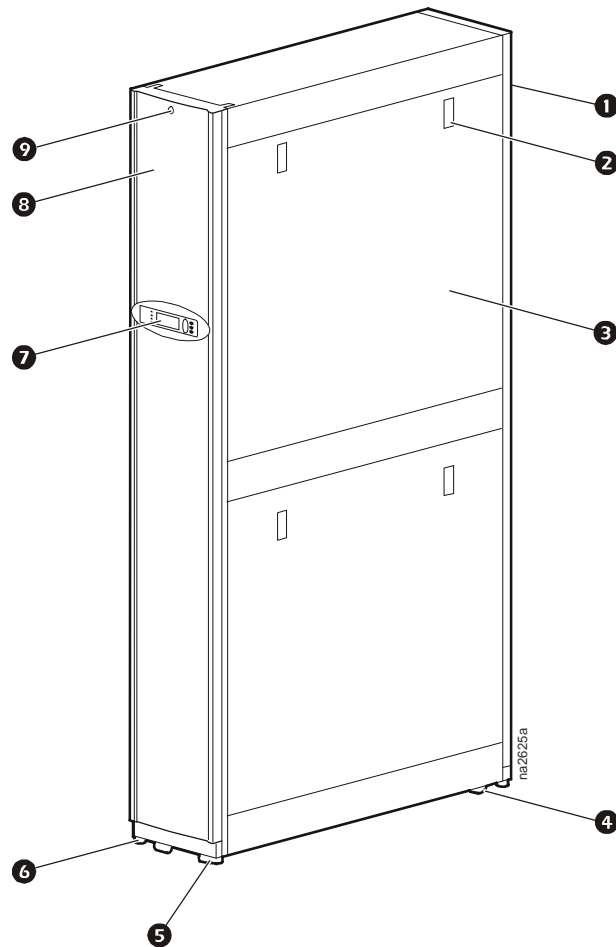

- |                                |                              |
|--------------------------------|------------------------------|
| ❶ Removable rear door          | ❹ Adjustable leveling feet   |
| ❷ Side panel latch             | ❺ Display interface          |
| ❸ Removable side panel         | ❻ Removable front door       |
| ❹ Rear casters (non-swiveling) | ❼ Door lock (front and rear) |
| ❺ Front casters (swiveling)    |                              |

## Interior components (front): ACRD100 series

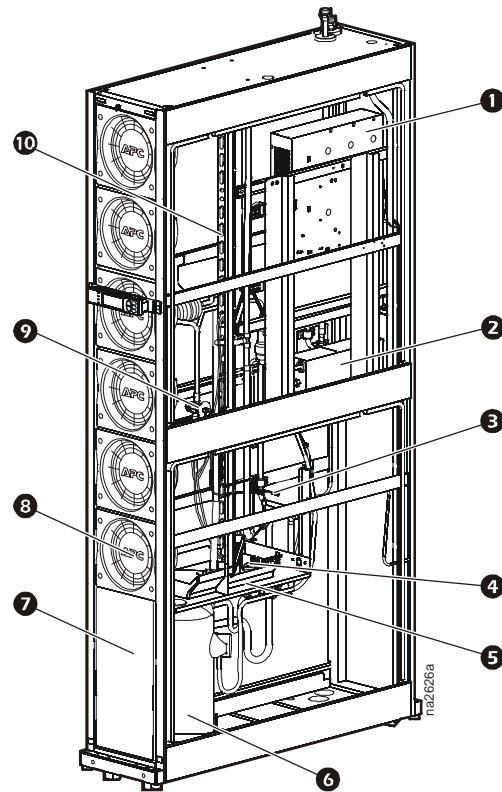

- |  |                                   |
|--|-----------------------------------|
| ❶ Electrical control box 1 (retractable) | ❸ Return air temperature sensor   |
| ❷ Electrical control box 2               | ❹ Condensate pan floats (2 total) |
| ❺ Front air block panel                  | ❻ Compressor                      |
| ❽ Evaporator fans (6 total)              | ❼ Condensate pan                  |
| ❾ Expansion valve                        | ❽ Evaporator coil                 |

## Interior components (rear): ACRD100 series

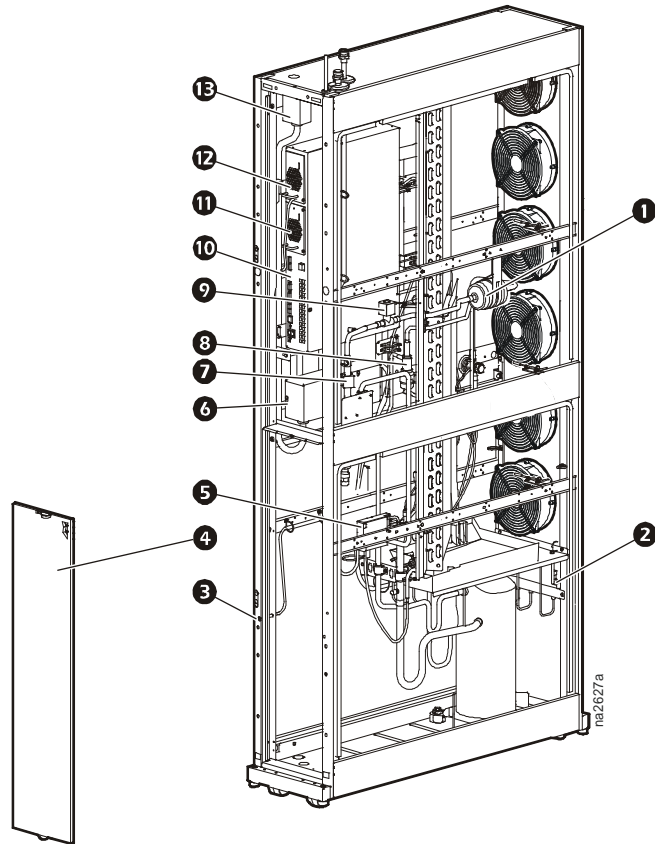

- |   |  |
|---|--|
| ① Filter/dryer  | ⑧ Hot gas bypass valve                   |
| ② Pressure transducer (2 total, located behind air block) | ⑨ Liquid line shutoff solenoid           |
| ③ Filter differential pressure port                       | ⑩ Electrical control box 1               |
| ④ Air filter (2 total)                                    | ⑪ Power supply unit (bottom)             |
| ⑤ Condensate pump (2 total)                               | ⑫ Power supply unit (top)                |
| ⑥ Electrical control box 2                                | ⑬ Service junction box (top entry shown) |
| ⑦ Sight glass   |  |

## Interior components (front): ACRD200 series

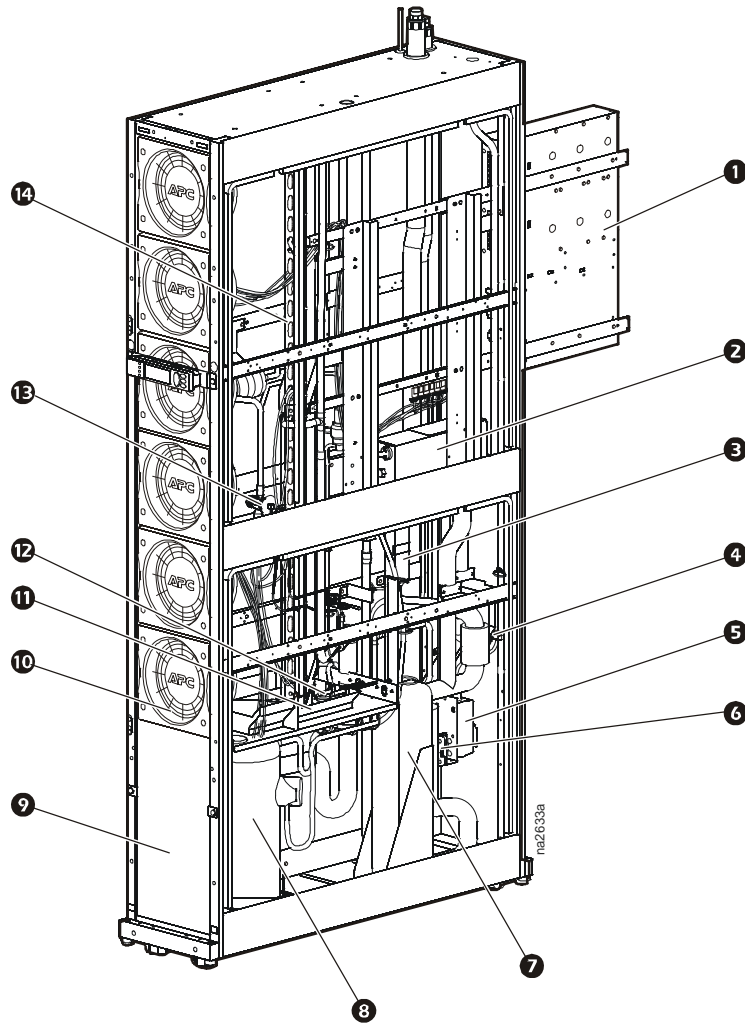

- |  |                                   |
|--|-----------------------------------|
| ❶ Electrical control box 1 (retractable) | ❸ Compressor                      |
| ❷ Electrical control box 2               | ❹ Front air block panel           |
| ❸ Condensate pumps (2 total)             | ❺ Evaporator fans (6 total)       |
| ❹ 2-way valve                            | ❻ Condensate pan                  |
| ❺ Water control actuator                 | ❼ Condensate pan floats (2 total) |
| ❻ 3-way valve                            | ❽ Expansion valve                 |
| ❼ Brazed plate heat exchanger            | ❿ Evaporator coil                 |

## Interior components (rear): ACRD200 series

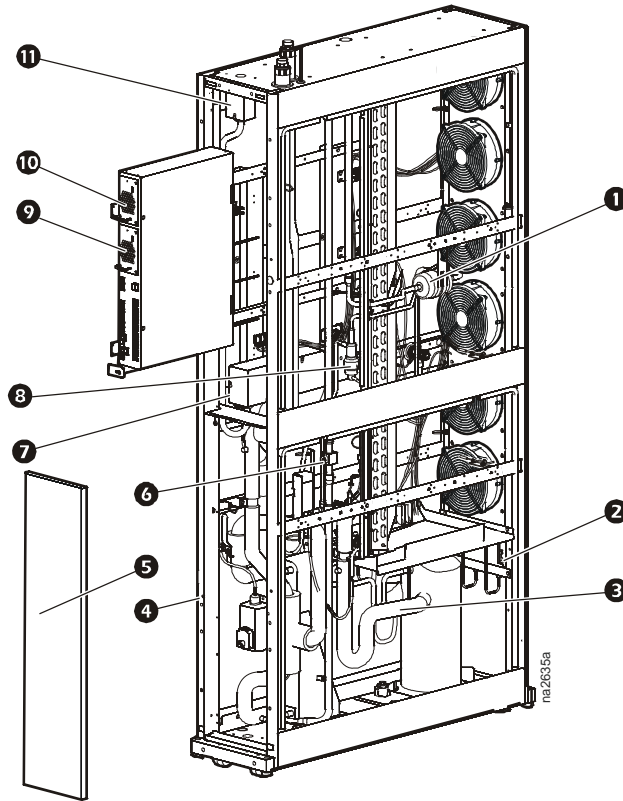

- |   |  |   |  |
|---|--|---|--|
| ❶ | Filter/dryer   | ❷ | Electrical control box 2               |
| ❸ | Pressure transducer (2 total, located behind airblock) | ❸ | Hot gas bypass valve                   |
| ❹ | Suction line   | ❹ | Power supply unit (bottom)             |
| ❺ | Filter differential pressure port                      | ❺ | Power supply unit (top)                |
| ❻ | Air filters (2 total)                                  | ❻ | Service junction box (top entry shown) |
| ❼ | Sight glass  |   |  |

## Exterior components: ACRD500 series

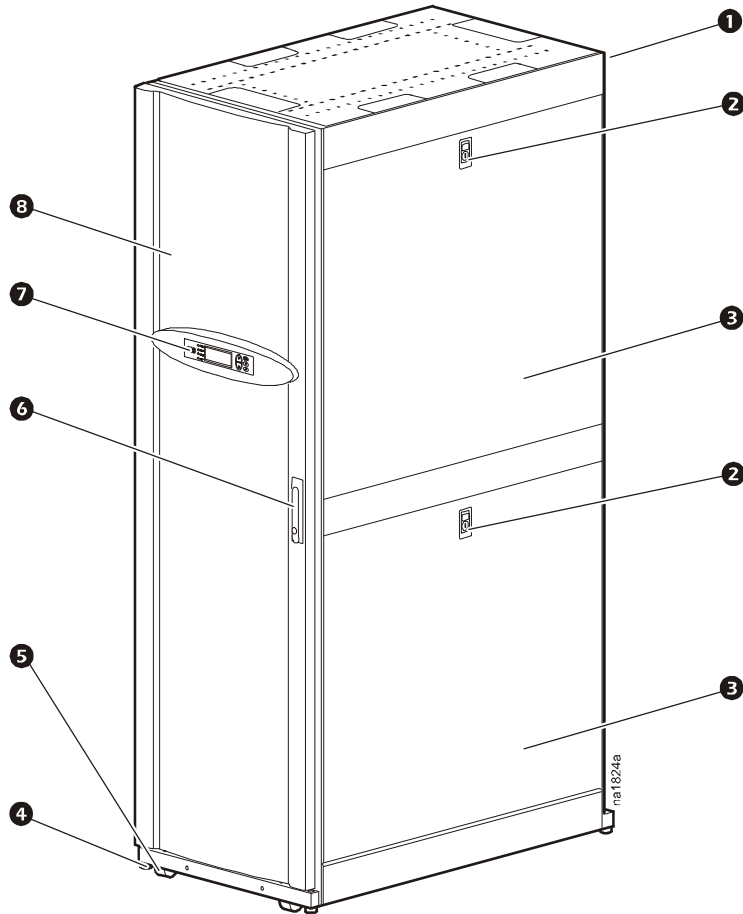

- |                            |                           |
|----------------------------|---------------------------|
| ❶ Removable rear doors     | ❺ Casters (all swiveling) |
| ❷ Side panel lock          | ❻ Door handle and lock    |
| ❸ Removable side panel     | ❼ Display interface       |
| ❹ Adjustable leveling feet | ❽ Removable front door    |

## Interior components (front): ACRD500 series

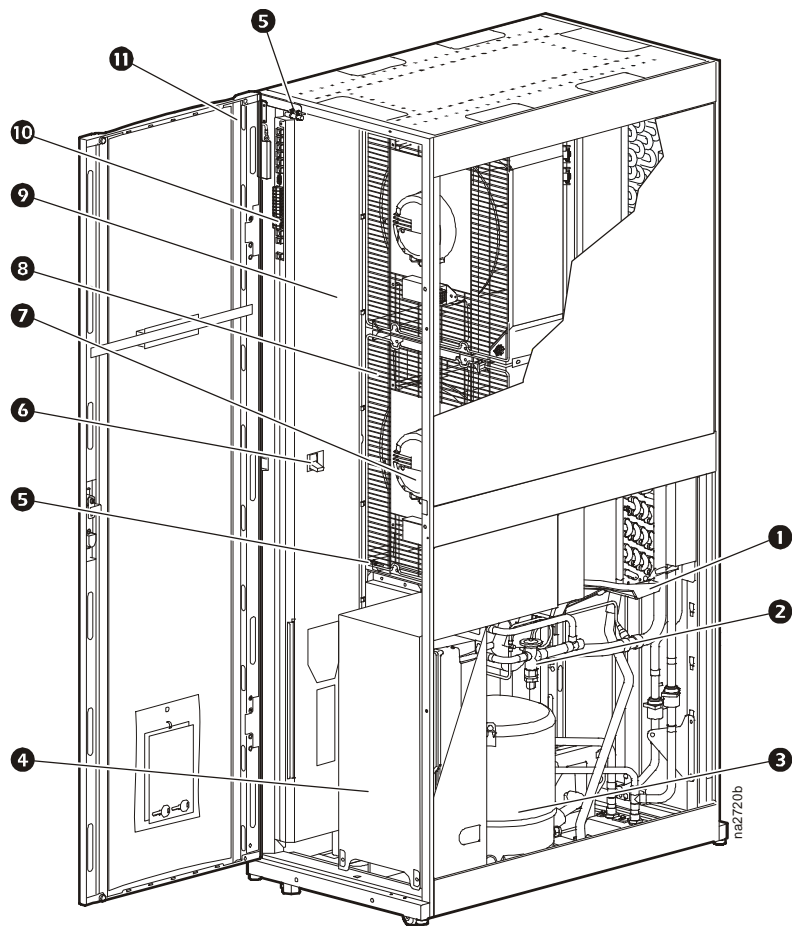

- |   |   |   |  |
|---|---|---|--|
| ❶ | Condensate drain pan                      | ❷ | Fan (2)                                      |
| ❸ | Thermal expansion valve                   | ❸ | Fan guard (2)                                |
| ❹ | Compressor                                | ❹ | Electrical panel                             |
| ❺ | Variable Frequency Drive (for compressor) | ❺ | Communication and external device connectors |
| ❻ | Supply air temperature sensor             | ❻ | Ground wire                                  |
| ❼ | Main circuit breaker                      |   |  |

## Interior components (rear): ACRD500 series

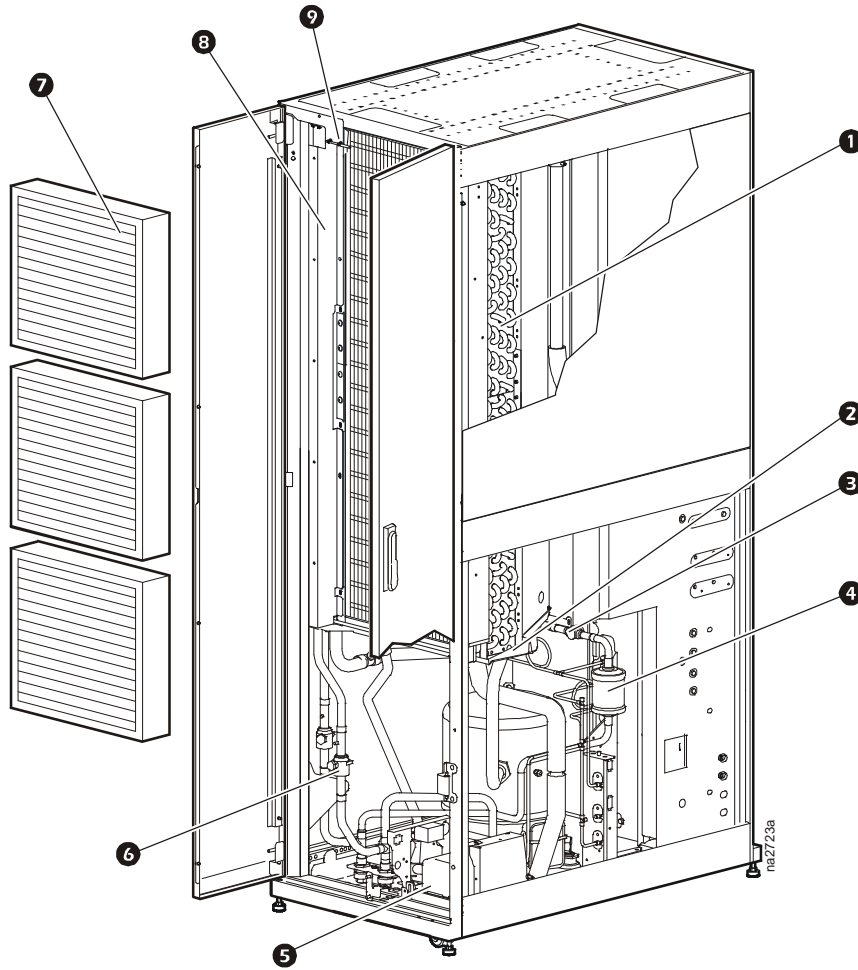

- |   |                      |   |                               |
|---|----------------------|---|-------------------------------|
| ❶ | Evaporator coil      | ❸ | Sight glass                   |
| ❷ | Condensate drain pan | ❹ | Filter dryer                  |
| ❺ | Condensate pump      | ❻ | Shutoff valves                |
|   |                      | ❼ | Air filters                   |
|   |                      | ❽ | Pipe chase                    |
|   |                      | ❾ | Return air temperature sensor |



## Electrical panel: ACRD100 and ACRD200 series

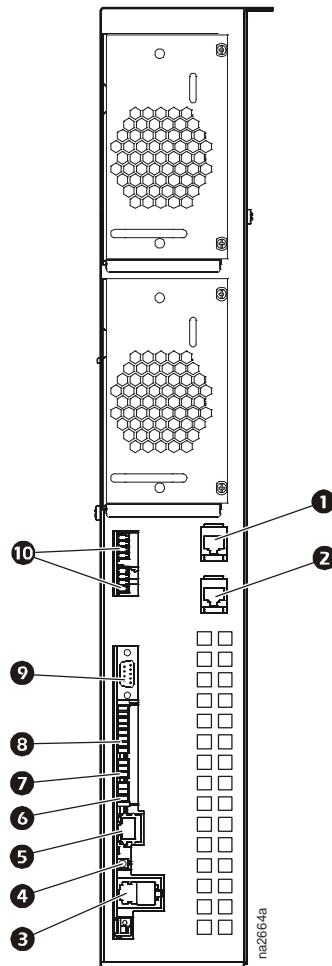

- |                                  |   |  |
|----------------------------------|---|--|
| ❶ Leak detector port             | ❸ A-Link ports  | ❹ RS-232 console port                          |
| ❷ Remote temperature sensor port | ❺ Network port  | ❺ Building management system (BMS) RS-485 port |
| ❸ A-Link ports                   | ❻ Building management system (BMS) RS-485 port  | ❻ Control RS-485 port                          |
| ❹ RS-232 console port            | ❼ Control RS-485 port   | ❼ Form C and shutdown input                    |
| ❺ Network port                   | ❽ Form C and shutdown input   | ❽ RS-232 console port                          |
|                                  | ❾ RS-232 console port   | ❾ RS-232 console port                          |
|                                  | ❿ Outdoor heat exchanger (OHE) input and output ports (optional connection for ACRD100 and ACRD101) |  |

# Electrical panel: ACRD500 series

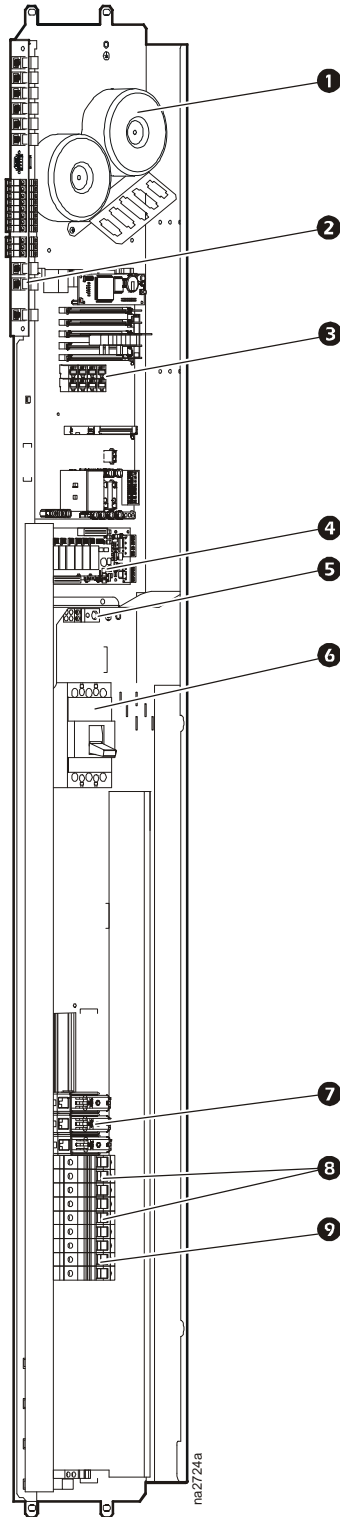

- ❶ Transformers
- ❷ User interface connectors
- ❸ Main controller board
- ❹ Relay board
- ❺ Ground lug
- ❻ Main circuit breaker
- ❼ Compressor fuse block (ACRD500, ACRD501)
- ❽ Compressor circuit breaker (ACRD502)
- ❾ Fan circuit breakers
- ❿ Controller circuit breaker

## User interface panel: ACRD500 series

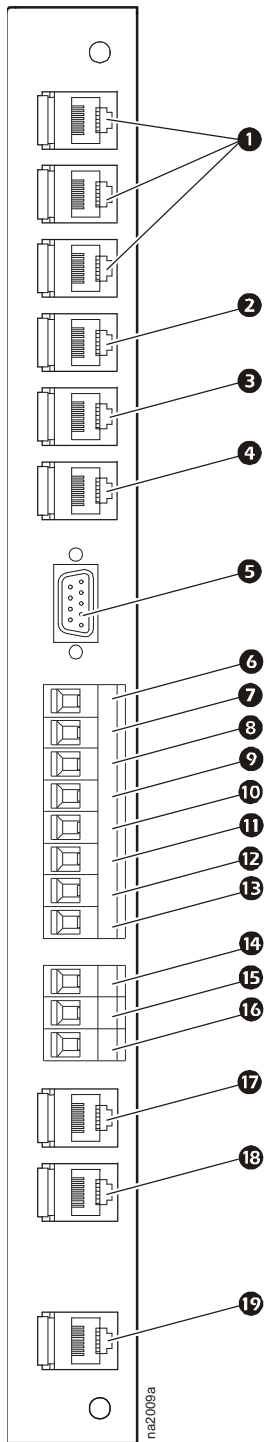

- ❶ Rack inlet temperature sensors 1, 2, 3
- ❷ A-Link IN
- ❸ A-Link OUT
- ❹ Network port
- ❺ Console port
- ❻ Alarm output, NC (Normally Closed)
- ❼ Alarm output, COM (Common)
- ❽ Alarm output, NO (Normally Open)
- ❾ Supply GND (Ground)
- ❿ Supply 12 Vdc (current limit: 20 mA)
- ⓫ Supply 24 Vdc (current limit: 20 mA)
- ⓬ Remote shutdown+ (12–30 Vac/Vdc, 24 Vdc @ 11 mA)
- ⓭ Remote shutdown-
- ⓮ BMS D1 (RXTX+)
- ⓯ BMS D0 (RXTX-)
- ⓰ BMS GND
- ⓱ Supply air temperature sensor (front)
- ⓲ Supply air humidity sensor (front)
- ⓳ Display interface

# Performance Specifications

## Net Cooling Capacity (Air and Glycol Cooled)

Return Air Temperature	SKU	Total Capacity kW (BTU/hr)	Sensible Capacity kW (BTU/hr)
<b>22.2°C DB, 15.5°C WB (72°F DB, 60°F WB)</b>	ACRD100	8.22 (28,000)	8.04 (27,400)
	ACRD101	8.01 (27,200)	7.71 (26,400)
	ACRD200	8.22 (28,000)	8.04 (27,400)
	ACRD201	8.01 (27,200)	7.71 (26,400)
	ACRD500 series	22.8 (78,000)	19.0 (65,000)
<b>23.9°C DB, 16.2°C WB (75°F DB, 61.1°F WB)</b>	ACRD100	8.52 (29,000)	8.52 (29,000)
	ACRD101	8.16 (27,900)	8.16 (27,900)
	ACRD200	8.52 (29,000)	8.52 (29,000)
	ACRD201	8.16 (27,900)	8.16 (27,900)
	ACRD500 series	25.2 (86,000)	21.7 (74,000)
<b>26.7°C DB, 19.4°C WB (80°F DB, 67.0°F WB)</b>	ACRD100	10.02 (34,000)	9.12 (31,000)
	ACRD101	9.72 (33,200)	8.85 (30,200)
	ACRD200	10.02 (34,000)	9.12 (31,000)
	ACRD201	9.72 (33,200)	8.85 (30,200)
	ACRD500 series	N/A	N/A
<b>26.7°C DB, 17.1°C WB (80°F DB, 62.8°F WB)</b>	ACRD100	9.36 (32,000)	9.36 (32,000)
	ACRD101	8.97 (30,700)	8.97 (30,700)
	ACRD200	10.02 (34,000)	9.12 (31,000)
	ACRD201	9.72 (33,200)	8.85 (30,200)
	ACRD500 series	26.9 (92,000)	26.9 (92,000)
<b>29.4°C DB, 18.1°C WB (85°F DB, 64.6°F WB)</b>	ACRD100	9.90 (33,800)	9.90 (33,800)
	ACRD101	9.69 (33,100)	9.69 (33,100)
	ACRD200	9.90 (33,800)	9.90 (33,800)
	ACRD201	9.69 (33,100)	9.69 (33,100)
	ACRD500 series	29.0 (99,000)	29.0 (99,000)
<b>32.2°C DB, 19.0°C WB (90°F DB, 66.2°F WB)<sup>1</sup></b>	ACRD100	10.44 (35,600)	10.44 (35,600)
	ACRD101	10.29 (35,200)	10.29 (35,200)
	ACRD200	10.44 (35,600)	10.44 (35,600)
	ACRD201	10.29 (35,200)	10.29 (35,200)
	ACRD500 series	30.5 (104,000)	30.5 (104,000)
<b>35.0°C DB, 19.9°C WB (95°F DB, 67.8°F WB)<sup>2</sup></b>	ACRD100	10.62 (36,200)	10.62 (36,200)
	ACRD101	10.5 (35,900)	10.5 (35,900)
	ACRD200	10.62 (36,200)	10.62 (36,200)
	ACRD201	10.5 (35,900)	10.5 (35,900)
	ACRD500 series	33.7 (115,000)	33.7 (115,000)
<b>37.8°C DB, 20.7°C WB (100°F DB, 69.3°F WB)<sup>3</sup></b>	ACRD100	10.62 (36,200)	10.62 (36,200)
	ACRD101	10.5 (35,900)	10.5 (35,900)
	ACRD200	10.62 (36,200)	10.62 (36,200)
	ACRD201	10.5 (35,900)	10.5 (35,900)
	ACRD500 series	36.9 (126,000)	36.9 (126,000)
<b>40.6°C DB, 21.6°C WB (105°F DB, 70.8°F WB)<sup>4</sup></b>	ACRD100	10.56 (36,000)	10.56 (36,000)
	ACRD101	10.5 (35,900)	10.5 (35,900)
	ACRD200	10.56 (36,000)	10.56 (36,000)
	ACRD201	10.5 (35,900)	10.5 (35,900)
	ACRD500 series	36.6 (125,000)	36.6 (125,000)
<b>43.3°C DB, 22.2°C WB (110°F DB, 72.0°F WB)<sup>5</sup></b>	ACRD100	10.6 (36,000)	10.6 (36,000)
	ACRD101	10.5 (35,900)	10.5 (35,900)
	ACRD200	10.6 (36,000)	10.6 (36,000)
	ACRD201	10.5 (35,900)	10.5 (35,900)
	ACRD500 series	N/A	N/A

Airflow for the ACRD100 and 200 series is 1081 l/s (2290 SCFM) at full evaporating fan speed.

Airflow for the ACRD500 series is 2171 l/s (4600 SCFM) at full evaporating fan speed.

<sup>1</sup>Airflow is reduced to 887 l/s (1880 SCFM) at this condition to maintain adequate evaporating temperature.

<sup>2</sup>Airflow is reduced to 717 l/s (1520 SCFM) at this condition to maintain adequate evaporating temperature.

<sup>3</sup>Airflow is reduced to 599 l/s (1270 SCFM) at this condition to maintain adequate evaporating temperature.

<sup>4</sup>Airflow is reduced to 510 l/s (1080 SCFM) at this condition to maintain adequate evaporating temperature.

<sup>5</sup>Airflow is reduced to 448 l/s (950 SCFM) at this condition to maintain adequate evaporating temperature.

Note: Minimum recommended loads: ACRD100 series and ACRD200 series - 2kW (6,831 BTU); ACRD500 series - 10kW (34,152 BTU)

Note: For ACRD100 and ACRD500 series the outdoor air temperature is 35° C (95° F)

Note: For ACRD200 series, a 40% at 0.64 l/s (10gpm), the entering glycol mixture temperature is 40.6° C (105° F)

## Net Cooling Capacity (Water Cooled)

Return Air Temperature	SKU	Total Capacity kW (BTU/hr)	Sensible Capacity kW (BTU/hr)
22.2°C DB, 15.5°C WB (72°F DB, 60°F WB)	ACRD200	9.72 (33,200)	8.94 (30,500)
	ACRD201	9.57 (32,700)	8.79 (30,100)
23.9°C DB, 16.2°C WB (75°F DB, 61.1°F WB)	ACRD200	8.43 (28,200)	8.43 (28,200)
	ACRD201	9.30 (31,800)	9.30 (31,800)
26.7°C DB, 19.4°C WB (80°F DB, 67.0°F WB)	ACRD200	11.52 (39,300)	9.90 (33,800)
	ACRD201	11.64 (39,800)	9.99 (34,200)
26.7°C DB, 17.1°C WB (80°F DB, 62.8°F WB)	ACRD200	10.38 (35,400)	10.38 (35,400)
	ACRD201	10.11 (34,500)	10.11 (34,500)
29.4°C DB, 18.1°C WB (85°F DB, 64.6°F WB)	ACRD200	10.92 (37,300)	10.92 (37,300)
	ACRD201	10.98 (37,500)	10.98 (37,500)
32.2°C DB, 19.0°C WB (90°F DB, 66.2°F WB) <sup>1</sup>	ACRD200	11.64 (39,700)	11.64 (39,700)
	ACRD201	11.76 (40,200)	11.76 (40,200)
35.0°C DB, 19.9°C WB (95°F DB, 67.8°F WB) <sup>2</sup>	ACRD200	12.00 (41,000)	12.00 (40,900)
	ACRD201	12.00 (41,000)	12.00 (41,000)
37.8°C DB, 20.7°C WB (100°F DB, 69.3°F WB) <sup>3</sup>	ACRD200	12.06 (41,200)	12.06 (41,200)
	ACRD201	12.00 (41,000)	12.00 (41,000)
40.6°C DB, 21.6°C WB (105°F DB, 70.8°F WB) <sup>4</sup>	ACRD200	12.06 (41,000)	12.00 (41,000)
	ACRD201	12.00 (41,000)	12.00 (41,000)
43.3°C DB, 22.2°C WB (110°F DB, 72.0°F WB) <sup>5</sup>	ACRD200	12.06 (41,200)	12.06 (41,200)
	ACRD201	12.06 (41,200)	12.06 (41,200)

Airflow for the ACRD200 series is 1081 l/s (2290 SCFM) at full evaporating fan speed.

<sup>1</sup>Airflow is reduced to 887 l/s (1880 SCFM) at this condition to maintain adequate evaporating temperature.

<sup>2</sup>Airflow is reduced to 717 l/s (1520 SCFM) at this condition to maintain adequate evaporating temperature.

<sup>3</sup>Airflow is reduced to 599 l/s (1270 SCFM) at this condition to maintain adequate evaporating temperature.

<sup>4</sup>Airflow is reduced to 510 l/s (1080 SCFM) at this condition to maintain adequate evaporating temperature.

<sup>5</sup>Airflow is reduced to 448 l/s (950 SCFM) at this condition to maintain adequate evaporating temperature.

Note: Minimum recommended loads: ACRD200 series - 2kW (6,831 BTU)

Note: For ACRD200 series, a 0.64 l/s (10gpm) entering water temperature is 29.4° C (85° F)

# Performance at Percentage of Fan Speed

## ACRD100 Series

% Fan Speed	Voltage/ Phase/Hz	L/S (SCFM)	Unit Power in kW	Condenser Fan Power in kW	Net Sensible Capacity kW (BTU/h)	SA Temp °C (°F)
<b>Return Air Temperature = 29.4° C (85° F)</b>						
30	200-240/1/60	448 (950)	2.57	0.13	4.60 (15,710)	20.8 (69.5)
	200-240/1/50		2.58	0.13	4.60 (15,710)	20.8 (69.5)
40	200-240/1/60	562 (1190)	2.67	0.18	5.75 (19,637)	20.8 (69.5)
	200-240/1/50		2.70	0.20	5.75 (19,637)	20.8 (69.5)
50	200-240/1/60	947 (1370)	2.76	0.23	6.65 (22,711)	20.8 (69.5)
	200-240/1/50		2.80	0.25	6.65 (22,711)	20.8 (69.5)
60	200-240/1/60	717 (1520)	2.86	0.28	7.35 (25,102)	20.8 (69.5)
	200-240/1/50		2.90	0.29	7.35 (25,102)	20.8 (69.5)
70	200-240/1/60	779 (1650)	2.92	0.32	8.00 (27,321)	20.8 (69.5)
	200-240/1/50		2.98	0.35	8.00 (27,321)	20.8 (69.5)
80	200-240/1/60	850 (1800)	3.04	0.38	8.70 (29,712)	20.8 (69.5)
	200-240/1/50		3.08	0.40	8.70 (29,712)	20.8 (69.5)
90	200-240/1/60	944 (2000)	3.19	0.47	9.70 (33,127)	20.8 (69.5)
	200-240/1/50		3.22	0.49	9.70 (33,127)	20.8 (69.5)
100	200-240/1/60	1081 (2290)	3.46	0.50	9.90 (33,810)	21.7 (71.1)
	200-240/1/50		3.50	0.51	9.90 (33,810)	21.9 (71.5)
<b>Return Air Temperature = 35° C (95° F)</b>						
30	200-240/1/60	448 (950)	2.68	0.28	7.55 (25,785)	20.8 (69.5)
	200-240/1/50		2.70	0.30	7.55 (25,785)	20.8 (69.5)
40	200-240/1/60	562 (1190)	2.80	0.42	9.50 (32,444)	20.8 (69.5)
	200-240/1/50		2.81	0.44	9.50 (32,444)	20.8 (69.5)
50	200-240/1/60	947 (1370)	2.89	0.48	10.20 (34,835)	21.8 (71.2)
	200-240/1/50		2.91	0.48	9.90 (33,810)	22.2 (71.9)
60	200-240/1/60	717 (1520)	3.00	0.52	10.62 (36,269)	22.6 (72.6)
	200-240/1/50		3.01	0.50	10.29 (35,142)	23.1 (73.5)
70	200-240/1/60	N/A	N/A	N/A	N/A	N/A
	200-240/1/50		N/A	N/A	N/A	N/A
80	200-240/1/60	N/A	N/A	N/A	N/A	N/A
	200-240/1/50		N/A	N/A	N/A	N/A
90	200-240/1/60	N/A	N/A	N/A	N/A	N/A
	200-240/1/50		N/A	N/A	N/A	N/A
100	200-240/1/60	N/A	N/A	N/A	N/A	N/A
	200-240/1/50		N/A	N/A	N/A	N/A
<b>Return Air Temperature = 40.6° C (105° F)</b>						
30	200-240/1/60	448 (950)	2.78	0.47	10.20 (34,835)	21.3 (70.4)
	200-240/1/50		2.78	0.48	10.00 (34,152)	21.6 (70.9)
40	200-240/1/60	562 (1190)	2.85	0.51	10.56 (36,064)	24.8 (76.6)
	200-240/1/50		2.87	0.53	10.55 (36,030)	24.8 (76.6)
50	200-240/1/60	N/A	N/A	N/A	N/A	N/A
	200-240/1/50		N/A	N/A	N/A	N/A
60	200-240/1/60	N/A	N/A	N/A	N/A	N/A
	200-240/1/50		N/A	N/A	N/A	N/A
70	200-240/1/60	N/A	N/A	N/A	N/A	N/A
	200-240/1/50		N/A	N/A	N/A	N/A
80	200-240/1/60	N/A	N/A	N/A	N/A	N/A
	200-240/1/50		N/A	N/A	N/A	N/A
90	200-240/1/60	N/A	N/A	N/A	N/A	N/A
	200-240/1/50		N/A	N/A	N/A	N/A
100	200-240/1/60	N/A	N/A	N/A	N/A	N/A
	200-240/1/50		N/A	N/A	N/A	N/A

## ACRD200 Series

% Fan Speed	Voltage/Phase/ Hz	L/S (SCFM)	Unit Power in kW	Net Sensible Capacity kW (BTU/h)	SA Temp °C (°F)
<b>Return Air Temperature = 29.4° C (85° F)</b>					
30	200-240/1/60	448 (950)	2.35	4.60 (15,710)	20.8 (69.5)
	200-240/1/50		2.25	4.60 (15,710)	20.8 (69.5)
40	200-240/1/60	562 (1190)	2.41	5.76 (19,671)	20.8 (69.5)
	200-240/1/50		2.31	5.76 (19,671)	20.8 (69.5)
50	200-240/1/60	947 (1370)	2.47	6.63 (22,643)	20.8 (69.5)
	200-240/1/50		2.37	6.63 (22,643)	20.8 (69.5)
60	200-240/1/60	717 (1520)	2.55	7.36 (25,136)	20.8 (69.5)
	200-240/1/50		2.45	7.36 (25,136)	20.8 (69.5)
70	200-240/1/60	779 (1650)	2.60	8.00 (27,321)	20.8 (69.5)
	200-240/1/50		2.50	8.00 (27,321)	20.8 (69.5)
80	200-240/1/60	850 (1800)	2.68	8.70 (29,712)	20.8 (69.5)
	200-240/1/50		2.58	8.70 (29,712)	20.8 (69.5)
90	200-240/1/60	944 (2000)	2.80	9.70 (33,127)	20.8 (69.5)
	200-240/1/50		2.70	9.70 (33,127)	20.8 (69.5)
100	200-240/1/60	1081 (2290)	3.06	10.90 (37,225)	21.0 (69.8)
	200-240/1/50		3.00	10.98 (37,499)	20.9 (69.7)
<b>Return Air Temperature = 35° C (95° F)</b>					
30	200-240/1/60	448 (950)	2.25	7.50 (25,614)	20.8 (69.5)
	200-240/1/50		2.25	7.50 (25,614)	20.8 (69.5)
40	200-240/1/60	562 (1190)	2.31	9.50 (32,444)	20.8 (69.5)
	200-240/1/50		2.31	9.50 (32,444)	20.8 (69.5)
50	200-240/1/60	947 (1370)	2.37	10.50 (35,859)	21.2 (70.)
	200-240/1/50		2.37	10.50 (35,859)	21.2 (70.)
60	200-240/1/60	717 (1520)	2.50	11.35 (38,762)	21.8 (71.3)
	200-240/1/50		2.45	11.35 (38,762)	21.8 (71.3)
70	200-240/1/60	779 (1650)	2.61	11.75 (40,128)	22.4 (72.4)
	200-240/1/50		2.50	11.75 (40,128)	22.4 (72.4)
80	200-240/1/60	850 (1800)	2.71	12.00 (40,982)	23.2 (73.7)
	200-240/1/50		2.58	12.00 (40,982)	23.2 (73.7)
90	200-240/1/60	N/A	N/A	N/A	N/A
	200-240/1/50		N/A	N/A	N/A
100	200-240/1/60	N/A	N/A	N/A	N/A
	200-240/1/50		N/A	N/A	N/A
<b>Return Air Temperature = 40.6° C (105° F)</b>					
30	200-240/1/60	448 (950)	2.35	10.55 36,030)	20.8 (69.5)
	200-240/1/50		2.25	10.55 36,030)	20.8 (69.5)
40	200-240/1/60	562 (1190)	2.40	11.70 (39,958)	22.8 (73.0)
	200-240/1/50		2.31	11.70 (39,958)	22.8 (73.0)
50	200-240/1/60	947 (1370)	2.46	12.00 (40,982)	24.8 (76.7)
	200-240/1/50		2.37	12.00 (40,982)	24.8 (76.7)
60	200-240/1/60	N/A	N/A	N/A	N/A
	200-240/1/50		N/A	N/A	N/A
70	200-240/1/60	N/A	N/A	N/A	N/A
	200-240/1/50		N/A	N/A	N/A
80	200-240/1/60	N/A	N/A	N/A	N/A
	200-240/1/50		N/A	N/A	N/A
90	200-240/1/60	N/A	N/A	N/A	N/A
	200-240/1/50		N/A	N/A	N/A
100	200-240/1/60	N/A	N/A	N/A	N/A
	200-240/1/50		N/A	N/A	N/A

## ACRD500 Series

% Fan Speed	Voltage	L/S (SCFM)	Unit Power in kW	Condenser Fan Power in kW	Net Sensible Capacity kW (BTU/h)	SA Temp °C (°F)
-------------	---------	------------	---------------------	---------------------------------	--	--------------------

**Return Air Temperature = 29.4° C (85° F)**

30	All	700 (1400)	2.03	0.01	7.3 (24,931)	20.8 (69.5) <sup>1</sup>
40	All	900 (1800)	3.25	0.02	9.8 (33,469)	20.8 (69.5) <sup>1</sup>
50	All	1100 (2300)	4.28	0.03	12.1 (41,324)	20.8 (69.5) <sup>1</sup>
60	All	1300 (2800)	6.32	0.06	14.5 (49,520)	20.8 (69.5)
70	All	1500 (3200)	7.12	0.07	16.9 (57,717)	20.8 (69.5)
80	All	1700 (3700)	9.13	0.10	19.4 (66,254)	20.8 (69.5)
90	All	2000 (4100)	9.52	0.18	21.8 (74,451)	20.8 (69.5)
100	All	2200 (4600)	11.74	0.31	24.2 (82,647)	20.8 (69.5)

**Return Air Temperature = 35° C (95° F)**

30	All	700 (1400)	4.28	0.05	11.95 (40,811)	20.8 (69.5) <sup>1</sup>
40	All	900 (1800)	6.51	0.08	15.93 (54,404)	20.8 (69.5)
50	All	1100 (2300)	7.65	0.14	19.91 (67,996)	20.8 (69.5)
60	All	1300 (2800)	10.19	0.20	23.89 (81,589)	20.8 (69.5)
70	All	1500 (3200)	12.28	0.27	27.87 (95,181)	20.8 (69.5)
80	All	1700 (3700)	14.66	0.45	30.6 (104,505)	21.4 (70.5)
90	All	2000 (4100)	15.09	0.55	33.0 (112,701)	21.9 (71.5)
100	All	2200 (4600)	15.69	0.60	33.7 (115,092)	23 (73.4)

**Return Air Temperature = 40.6° C (105° F)**

30	All	700 (1400)	7.13	0.09	16.6 (56,692)	20.8 (69.5) <sup>1</sup>
40	All	900 (1800)	9.46	0.28	22.2 (75,817)	20.8 (69.5)
50	All	1100 (2300)	11.77	0.57	27.7 (94,600)	20.8 (69.5)
60	All	1300 (2800)	13.96	0.93	29.6 (101,089)	21.1 (70.0)
70	All	1500 (3200)	14.43	1.00	34.5 (117,824)	23 (73.4)
80	All	1700 (3700)	14.93	1.04	35.6 (121,580)	24.7 (76.5)
90	All	2000 (4100)	15.58	1.25	36.5 (124,654)	26.1 (79.0) <sup>2</sup>
100	All	2200 (4600)	16.17	1.55	37.9 (129,435)	27.1 (80.7) <sup>2</sup>

<sup>1</sup> In this case, the compressor will cycle because its speed is down to the minimum of 35 Hz.

The minimum fan speed for the InRow mode is 30%; the minimum fan speed for HACS and RACS mode is 40%.

<sup>2</sup> SA temperature is above 25° C (77° F)

Note: Outdoor temperature is 35° C (95° F)



# General Data

## General Specifications - ACRD200 Series

Data	Units	Water Cooled	Glycol Mixture Cooled
Nominal flow rate entering to the unit	l/s (gpm)	0.64 (10.0)	0.64 (10.0)
Design entering temperature	°C (°F)	29.4 (85.0)	40.6 (105.0)
Maximum heat rejection	kW (Btu/hr)	15.2 (52,000)	15.2 (52,000)
Maximum glycol percentage	%	0	40
Entering temperature range for 0.64 l/s (10 gpm) flow rate entering to the unit	°F (°C)	12.8 - 43.3 (55.0 - 110.0)	12.8 - 43.3 (55.0 - 110.0)
Unit pressure drop at 0.64 l/s (10 gpm)	kPa (psi)	33.1 (4.8)	43.4 (6.3)

### Fluid-cooled

MODEL	ACRD200 Series
<b>AIR SYSTEM - FAN (Standard Filter Installed)</b>	
Size - mm (in)	200 (7.9)
Air Volume - l/s (SCFM)	1080 (2290)
Fan Motor - W (HP) each	115 (0.15)
Number of Fans	6
<b>COOLING COIL - COPPER TUBE/ALUMINUM FIN</b>	
Face Area - m <sup>2</sup> (ft <sup>2</sup> )	0.37 (3.97)
Rows Deep	2
<b>FILTERS - WASHABLE (STANDARD)</b>	
Quantity	2
Size - mm (in)	238 X 933 (9.375 X 36.75)
Depth - mm (in)	13 (1/2)
Efficiency (%)	<20% MERV 1
<b>FILTERS - PLEATED (OPTIONAL)</b>	
Quantity	2
Size - mm (in)	238 X 933 (9.375 X 36.75)
Depth - mm (in)	51 (2)
Efficiency (%)	30% MERV 8
<b>PHYSICAL DATA</b>	
Weight - kg (lbs)	199.09 (438)
Height - mm (in)	1991 (78.39)
Width - mm (in)	300 (11.8)
Depth - mm (in)	1070 (42.13)
<b>CONNECTION SIZES</b>	
<b>Liquid</b>	
In	7/8-in O DF brazed
Return	7/8-in ODF brazed
<b>Condensate Drain</b>	
Drain Line - in	3/16-in ID, 5/16-in OD
<b>REFRIGERANT</b>	
Type	R410A
Charge - kg (oz)	2.4 (84)

## Air-Cooled

Data	SKU	Value
<b>AIR SYSTEM - FAN (Standard Filter Installed)</b>		
Size - mm (in)	ACRD100	200 (7.9)
	ACRD101	200 (7.9)
	ACRD500 series	400 (15.8)
Air Volume - l/s (SCFM)	ACRD100	1080 (2290)
	ACRD101	1080 (2290)
	ACRD500 series	2124 (4500)
Fan Motor - W (HP) each	ACRD100	115 (0.15)
	ACRD101	115 (0.15)
	ACRD500 series	1100 (1.5)
Number of Fans	ACRD100 series	6
	ACRD500 series	2
<b>COOLING COIL - COPPER TUBE/ALUMINUM FIN</b>		
Face Area - m <sup>2</sup> (ft <sup>2</sup> )	ACRD100	0.37 (3.97)
	ACRD101	0.37 (3.97)
	ACRD500 series	0.56 (6.0)
Rows Deep	ACRD100	2
	ACRD101	2
	ACRD500 series	4
<b>FILTERS - WASHABLE (STANDARD)</b>		
Quantity	ACRD100 series	2
Size - mm (in)		238 X 933 (9.375 X 36.75)
Depth - mm (in)		13 (1/2)
Efficiency (%)		<20% MERV 1
<b>FILTERS - PLEATED (STANDARD)</b>		
Quantity	ACRD500 series	4
Size - mm (in)		418 x 470 (16.45 x 18.5)
Depth - mm (in)		101.6 (4)
Efficiency (%)		30
<b>FILTERS - PLEATED (OPTIONAL)</b>		
Quantity	ACRD100 series	2
Size - mm (in)		238 X 933 (9.375 X 36.75)
Depth - mm (in)		51 (2)
Efficiency (%)		30% MERV 8
<b>FILTERS - PLEATED (OPTIONAL)</b>		
Quantity	ACRD500 series	4
Size - mm (in)		418 x 470 (16.45 x 18.5)
Depth - mm (in)		101.6 (4)
Efficiency (%)		85
<b>PHYSICAL DATA</b>		
Weight - kg (lbs)	ACRD100 series	183 (404)
	ACRD500 series	367 (808)
Height - mm (in)	ACRD100 series	1991 (78.39)
	ACRD500 series	1991 (78.39)
Width - mm (in)	ACRD100 series	300 (11.8)
	ACRD500 series	600 (23.62)
Depth - mm (in)	ACRD100 series	1070 (42.13)
	ACRD500 series	1070 (42.13)
<b>CONNECTION SIZES</b>		
<b>Refrigerant</b>		
Discharge	ACRD100 series	1/2 in ODF brazed
	ACRD500 series	7/8 in ODF brazed
Maximum pressure drop - bar (PSI)	ACRD100	0.7 (10)
	ACRD101	0.7 (10)
	ACRD500 series	0.7 (10)
		0.7 (10)
Liquid	ACRD100 series	1/2 in ODF brazed
	ACRD500 series	7/8 in ODF brazed
<b>Condensate Drain</b>		
Drain Line - in	ACRD100 series	3/16-in ID, 5/16-in OD
	ACRD500 series	1/2
<b>REFRIGERANT</b>		
Type	ACRD100 series	R410A (amount determined at installation)
	ACRD500 series	R407C (amount determined at installation)

## Altitude Correction Factors

Room Condition: 72 DB/50% RH

Altitude (ft)	0	1000	2000	3000	4000	5000	6000	7000	8000	9000	10000
Specific volume (ft <sup>3</sup> /lb)	13.58	14.09	14.62	15.18	15.76	16.36	17.00	17.67	18.37	19.11	19.89
Density (lb/ft <sup>3</sup> )	0.074	0.071	0.068	0.066	0.063	0.061	0.059	0.057	0.054	0.052	0.050
Density Ratio	1.000	0.964	0.929	0.895	0.862	0.830	0.799	0.769	0.739	0.711	0.683
Capacity Correction	1.000	0.981	0.962	0.933	0.913	0.884	0.865	0.846	0.826	0.807	0.787

Density ratio is used for air flow correction factor.

Capacity correction is used to derate performance.

## Sound Performance Data

ACRD100 and ACRD200 Series Tested Sound Data												
Fan Speed %	Fan RPM	Airflow m <sup>3</sup> /s (SCFM)	Sound Power dB at Frequency Hz re: 10 <sup>-12</sup> W								Lp Sound Pressure dB re: 20 μPa*	
			125	250	500	1000	2000	4000	8000	dBA**	dBA	
100	4300	1.08 (2290)	70.3	80.8	83.3	85.3	80.3	77.8	72.3	88.3	82.2	
90	3800	0.92 (1950)	68.3	81.8	78.8	80.8	77.3	74.3	68.3	84.5	78.4	
80	3450	0.85 (1800)	67.3	80.3	77.3	78.2	76.3	71.8	66.3	82.7	76.6	
70	3000	0.78 (1650)	65.3	76.3	74.8	77.8	73.8	67.8	61.3	80.8	74.7	
60	2300	0.66 (1400)	62.3	68.3	69.8	74.8	67.8	59.3	53.3	76.5	70.5	

\*Weighted Sound Pressure dBA in a 28.3 m<sup>3</sup> (1000 ft<sup>3</sup>) room at 1.5 m (5-ft) distance.

\*\*Based on compressor operating at full speed.

ACRD500 Series Air-cooled Tested Sound Data											
Fan Speed%	Airflow m <sup>3</sup> /s (SCFM)	Sound Power dB at Frequency Hz re: 10 <sup>-12</sup> W								Lp Sound Pressure dB re: 20 μPa*	
		125	250	500	1000	2000	4000	8000	dBA**	dBA	
50	1.27 (2700)	84.5	87.5	78.0	77.5	75.0	66.5	65.5	83.4	72.8	
75	1.79 (3800)	92.5	90.0	84.0	81.5	77.5	71.5	68.5	87.6	76.8	
100	2.36 (5000)	90.0	98.0	91.0	85.0	81.0	76.5	72.0	92.3	82.8	

\*Weighted Sound Pressure dBA in an 8200 ft<sup>3</sup> (232.2 m<sup>3</sup>) room at 6 ft (1.8 m) distance.

\*\*Based on compressor operating at full speed.

### Electrical Data

SKU	MCA	MOP	FLA	Compressor		Power
				LRA	RLA	
ACRD100 208-240V, 60Hz	25	40	N/A	87.5	16.0	4.6
ACRD101 220-240V, 50Hz	N/A	N/A	21	97.0	16.3	4.4
ACRD200 208-240V, 60Hz	25	40	N/A	87.5	16.0	4.6
ACRD201 220-240V, 50Hz	N/A	N/A	21	97.0	16.3	4.4
ACRD500 200-240V, 50/60Hz	54.0	90	-	160*	50	15
ACRD501 460-480V, 60Hz	27.0	40	-	139*	23.2	16
ACRD502 380-415V, 50Hz	-	-	26.0	139*	23.2	16

Note: Above data is based on maximum operating condition

Note: Installation must comply with national and/or local electrical codes.

Note: Use LRA for estimation of inrush current.

\* The compressor is powered by the VFD.

MCA-Minimum Circuit Ampacity

MOP-Maximum Overcurrent Protection

LRA-Compressor Locked Rotor Amps

RLA-Compressor Rated Load Amps

FLA-Full Load Amps

# Dimensional Data

ACRD100 and ACRD200 series

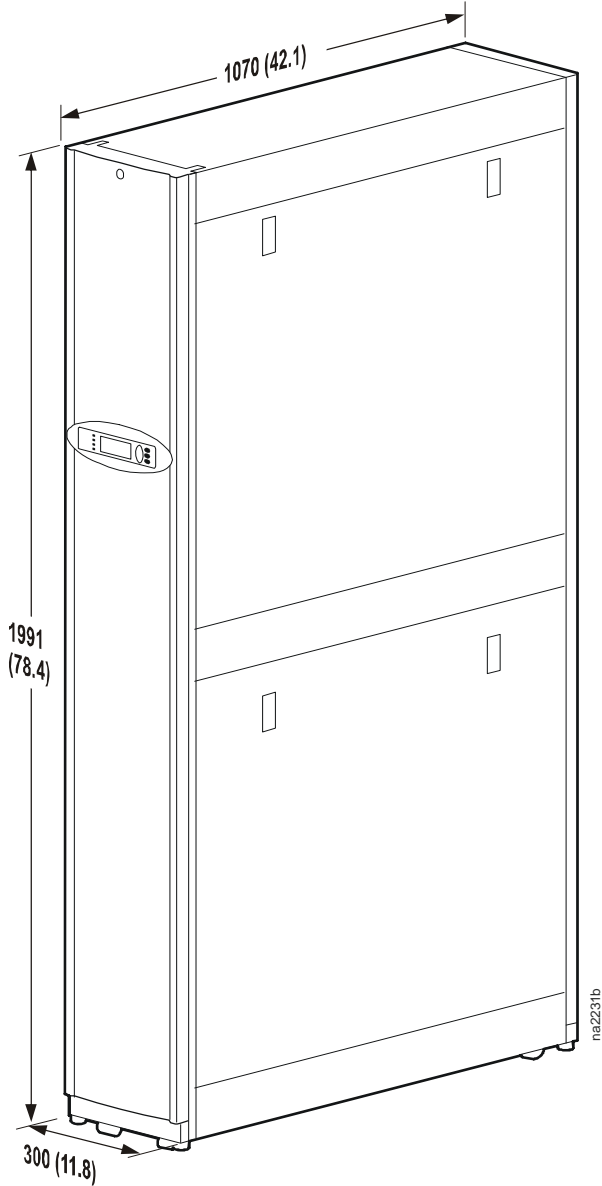

Dimensions are shown in mm (in).

## ACRD500 series

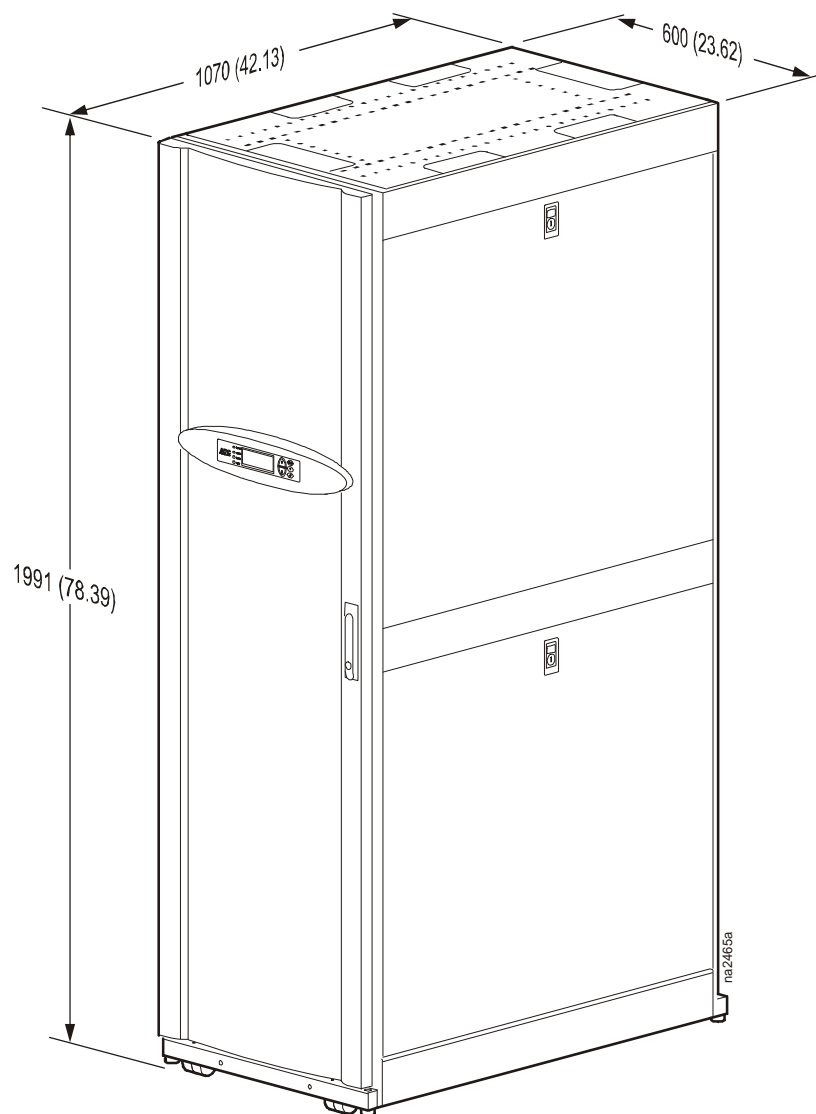

Dimensions are shown in mm (in).

**NetShelter SX to VX Height Adapter: ACRD100 and ACRD200 series**

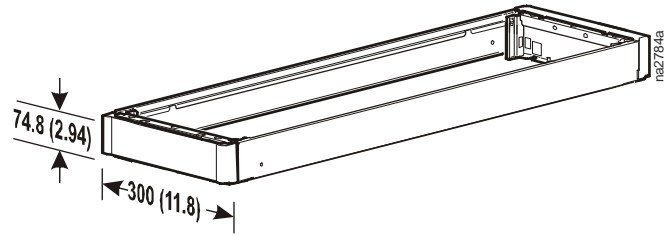

**NetShelter SX to VX Height Adapter: ACRD500 series**

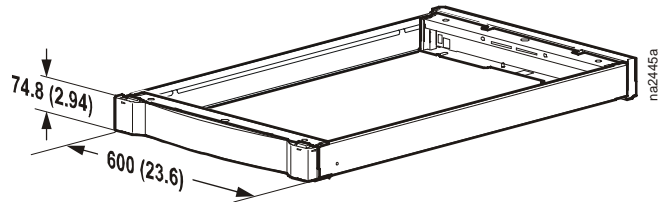

**NetShelter SX to 48-U SX Height Adapter: ACRD100 and ACRD200 series**

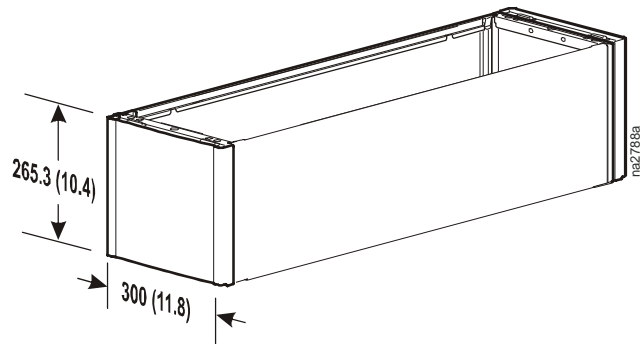

**NetShelter SX to 48-U SX Height Adapter: ACRD500 series**

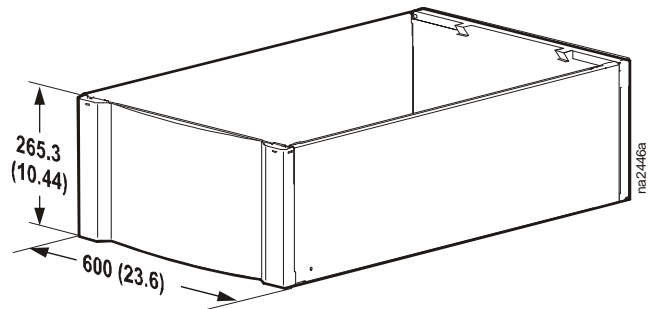

Dimensions are shown in mm (in).

# Piping and Mechanical Connections

## Refrigeration Piping Diagram (ACRD100 and ACRD500 series)

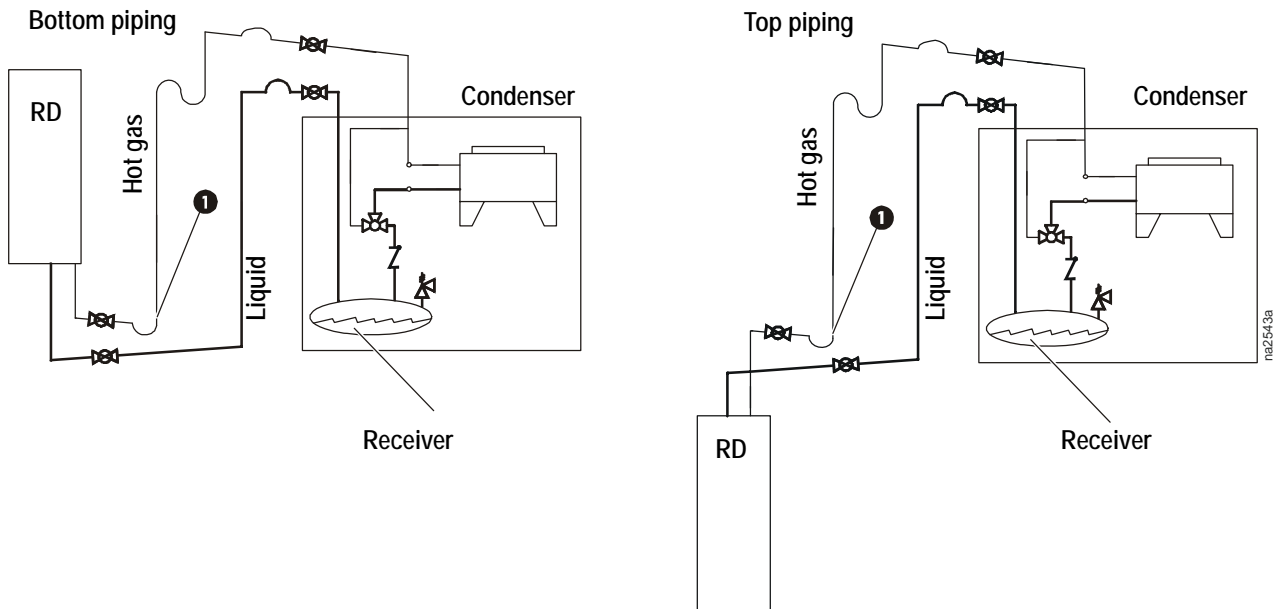

**Note:** Shutoff valves shown nearest to the condensers are not supplied by APC.



Pitch in direction of refrigerant flow; 4 mm per m (1/2 in per 10 ft)



Shutoff valves



Head pressure control valve



Check valve



P-trap



S-trap



Inverted P-trap



Pressure relief valve



**Note:** Route piping through the top or bottom of the InRow RD.

**Note:** All lines are Type L ACR copper tubing.

**Note:** Trap the vertical discharge line every 6 m (20 ft) to ensure proper oil return.

**Note:** Pipe size should change after the P-trap based on the recommended piping charts provided with the installation manual. See the piping diagram created for your site.

**Note:** The maximum piping run is 61 m (200 ft) equivalent length. Size the piping pursuant to accepted refrigeration practice.

**Note:** ACRD100 series only: any equivalent length greater than 46m (150 ft) will result in a 5% decrease in capacity.



**Warning:** Do not install the air-cooled condenser below the InRow RD. The condenser must be positioned above or at the same level as the InRow RD to ensure proper function.



## Water cooled piping (ACRD200 series)



**Note:** Bottom piping shown.

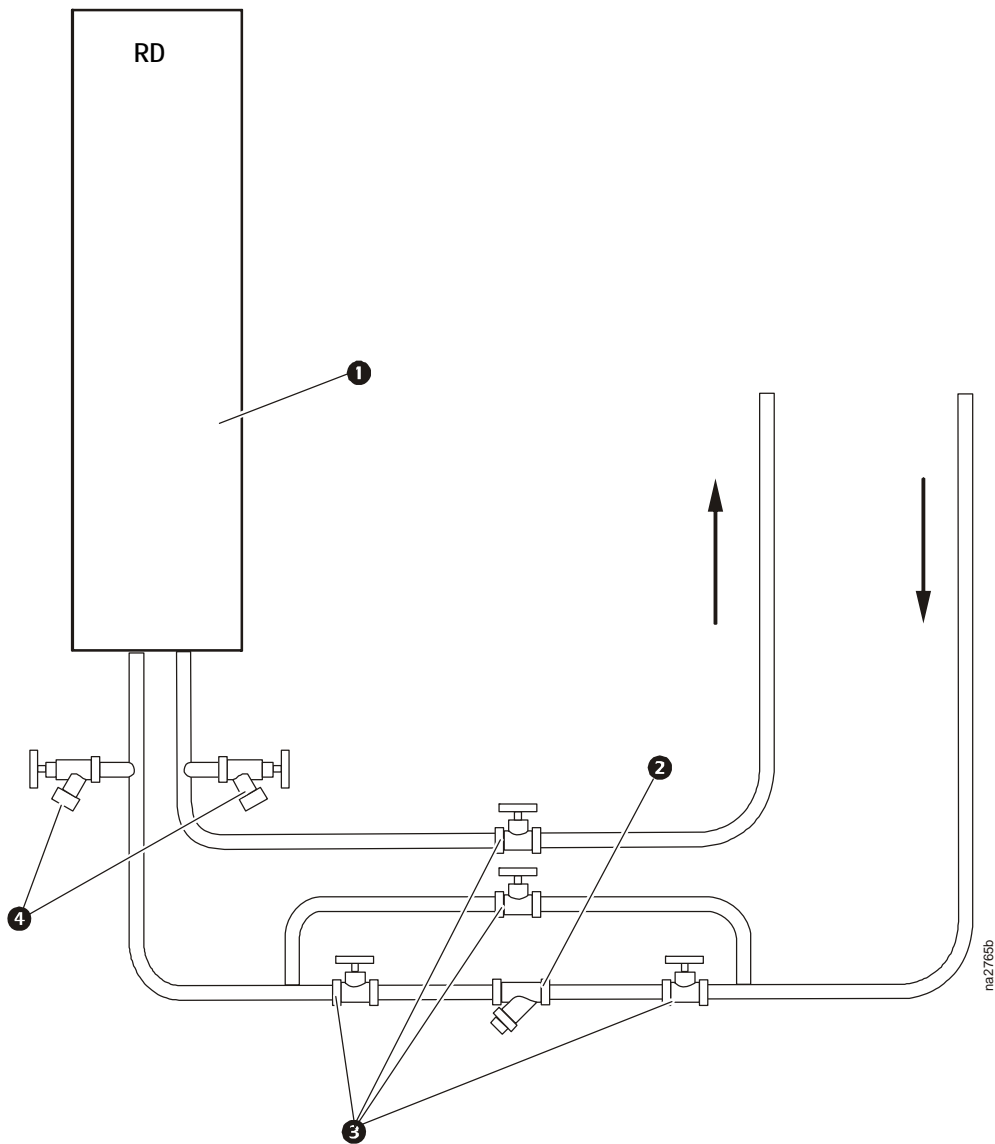

- |                      |               |
|----------------------|---------------|
| ❶ InRow RD           | ❸ Gate valve* |
| ❷ Strainer, 20 mesh* | ❹ Hose bib*   |

\* Field supplied and installed

## Glycol cooled piping (ACRD200 series)



**Note:** Bottom piping shown.

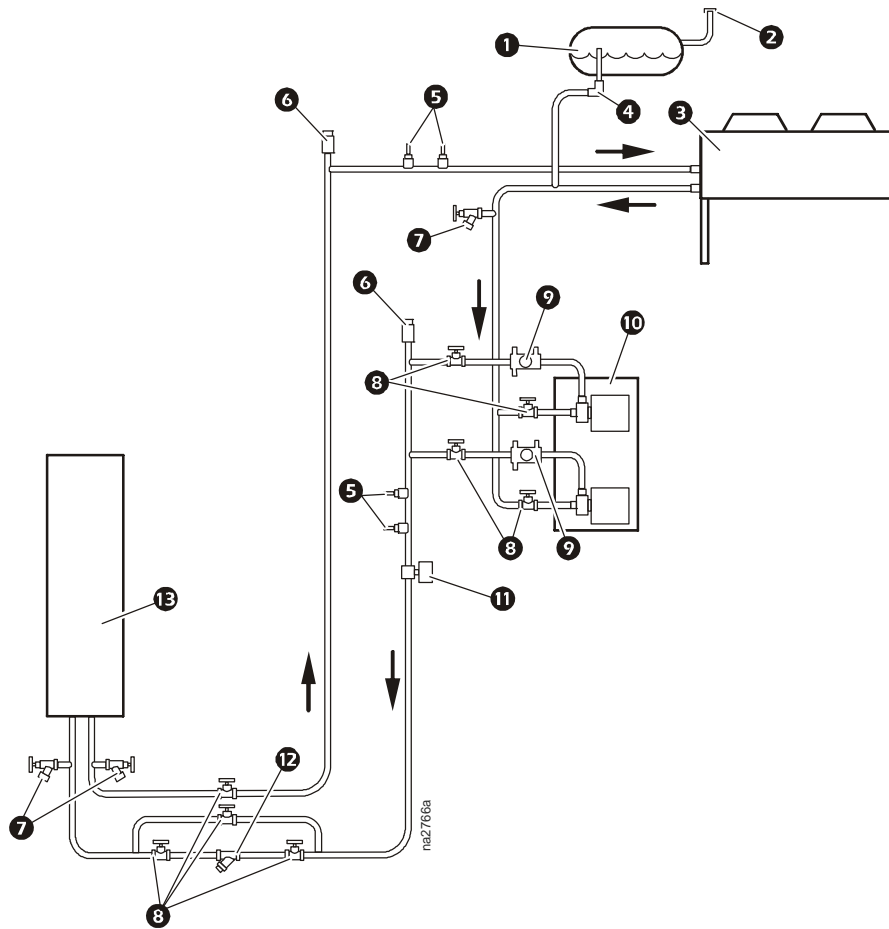

- |                                    |                      |
|------------------------------------|----------------------|
| ❶ Expansion tank*                  | ❷ Hose bibs*         |
| ❷ Tank fill*                       | ❸ Gate valves*       |
| ❸ Fluid-cooler                     | ❹ Pump package*      |
| ❹ Airtrol fitting*                 | ❺ Flow switch        |
| ❺ Temperature and pressure gauges* | ❻ Strainer, 20 mesh* |
| ❻ Air vent*                        | ❼ InRow RD           |

\* Field supplied and installed

## Top piping and power access locations (ACRD100 series and ACRD200 series)

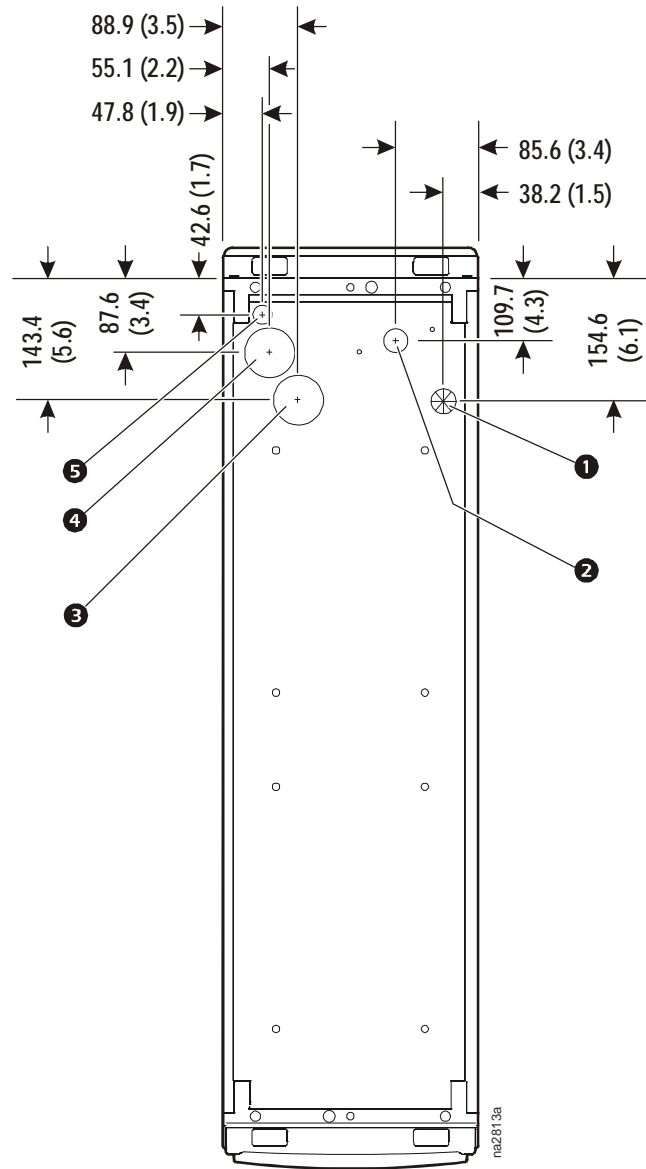

Dimensions are shown in mm (in).

- |  |  |
|--|--|
| ❶ Low voltage wiring input   | ❷ Liquid line (ACRD100 series)<br>Water/glycol in (ACRD200 series) |
| ❸ Electrical input   | ❹ Condensate pump outlet   |
| ❺ Hot gas discharge line (ACRD100 series)<br>Water/glycol out (ACRD200 series) |  |

### Bottom piping and power access locations (ACRD100 series and ACRD200 series)

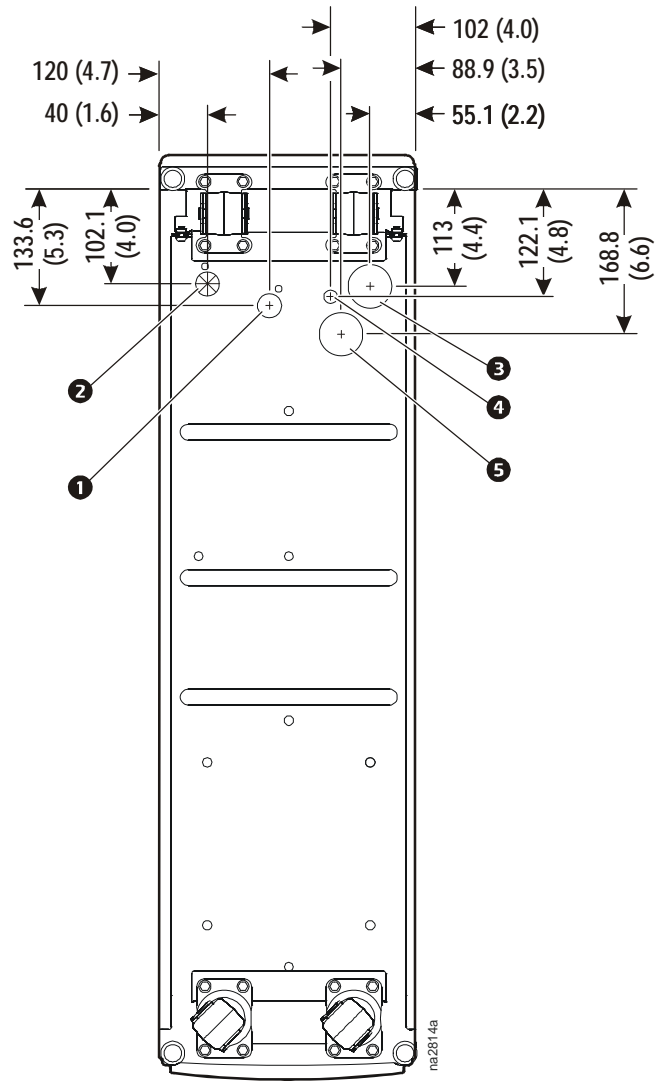

Dimensions are shown in mm (in).

- 1 Electrical input
- 2 Low voltage wiring input
- 3 Liquid line (ACRD100 series)  
Water/glycol in (ACRD200 series)
- 4 Condensate pump outlet
- 5 Hot discharge gas line (ACRD100 series)  
Water/glycol out (ACRD200 series)

## Top piping and power access locations (ACRD500 series)

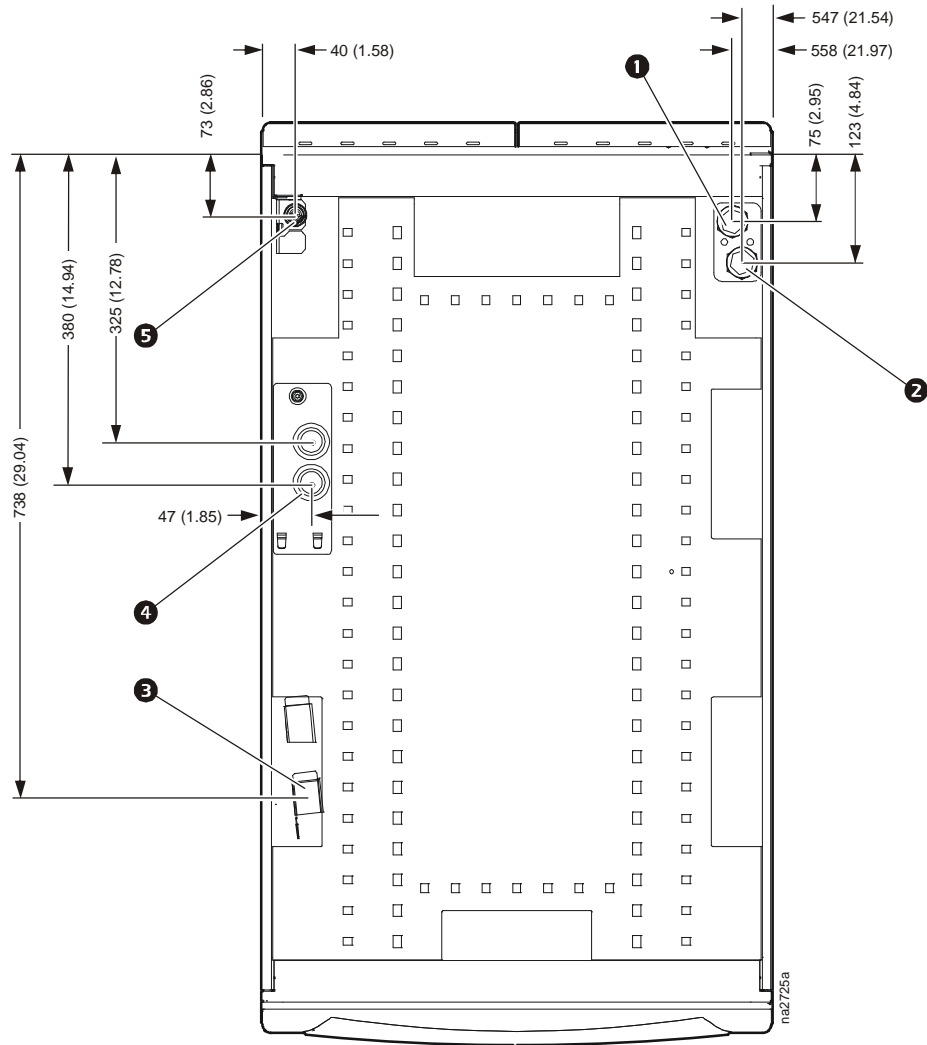

Dimensions are shown in mm (in).

- ❶ Refrigerant discharge line
- ❷ Refrigerant liquid line
- ❸ Trough for communication cables
- ❹ Power connections
- ❺ Condensate drain

## Bottom piping and power access locations (ACRD500 series)

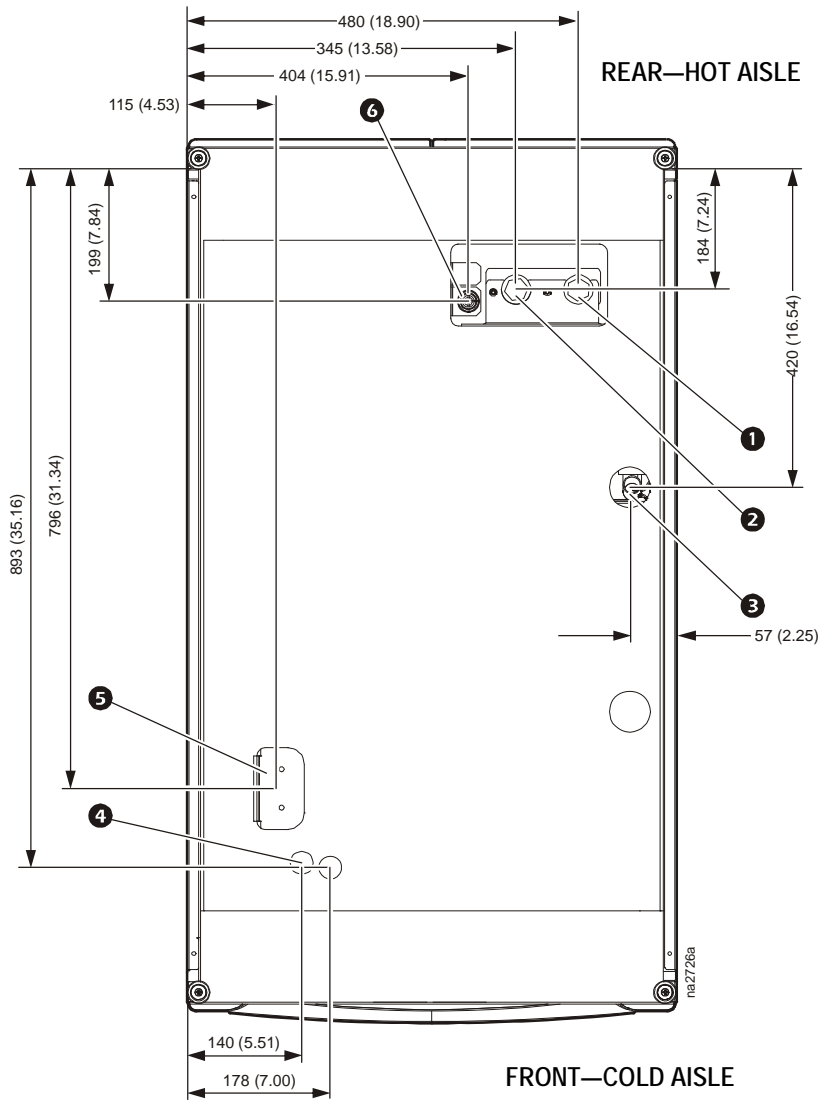

Dimensions are shown in mm (in).

- ❶ Refrigerant liquid line
- ❷ Refrigerant discharge line
- ❸ Condensate overflow—50.00 mm (1.97 in)
- ❹ Communication connections—27.80 mm (1.09 in)
- ❺ Power connections
- ❻ Condensate drain

# Outdoor Heat Exchangers

## Air Cooled Condensers - Mechanical Data (ACRD100 Series)

SKU	Ambient Temp °C (°F)	Sound Pressure (dbA) at 10 ft and 100% Fan Speed	Air Quantity	Fan	Unit	Connection Size		Weight	Capacity	
			l/s (CFM)	Qty.	kW	Hot Gas	Liquid	Kg (Lbs)	MBH/1F TD	kW/1C TD
ACCD75214	35 (95) / 40 (104)	65	2380 (5050)	1	1.1	1 1/8 in	7/8 in	82 (180)	2.43	1.28
ACCD75215	46 (115)	66	3040 (6450)	1	1.1	1 1/8 in	7/8 in	118 (260)	4.00	2.11
ACCD75216	35 (95) / 40 (104)	59	2140 (4530)	1	0.8	22 mm	18 mm	48 (105.8)	2.35	1.24
ACCD75217	46 (115)	62	4280 (9060)	2	1.6	28 mm	22 mm	89 (196.2)	4.30	2.27
ACCD75218	35 (95) / 40 (104)	59	2140 (4530)	1	0.6	22 mm	18 mm	48 (105.8)	2.35	1.24
ACCD75219	46 (115)	62	4280 (9060)	2	1.3	28 mm	22 mm	89 (196.2)	4.30	2.27

## Air Cooled Condensers - Mechanical Data (ACRD500 Series)

SKU	Ambient Temp °C (°F)	Sound Pressure (dbA) at 10 ft and 100% Fan Speed	Sounds Pressure (dbA) at 10 ft set area level, and Max Compressor Speed Selected Ambient Temp	Air Quantity	Fan	Unit	Connection Size (inches)		Weight	Capacity	
				l/s (CFM)	Qty.	kW	Hot Gas	Liquid	Kg (Lbs)	MBH/1F TD	kW/1C TD
ACCD75201	95 (35)	67	62	4955 (10500)	1	2.2	1 3/8	1 3/8	163 (360)	8.8	4.6
ACCD75202	105 (40)	70	65	10383 (22000)	2	4.4	1 5/8	1 5/8	290 (640)	14.6	7.7
ACCD75203	115 (46)	72	68	14819 (31400)	3	6.6	2 1/8	2 1/8	458 (1010)	25.8	13.6
ACCD75204	95 (35)	67	62	4955 (10500)	1	2.2	1 3/8	1 3/8	163 (360)	8.8	4.6
ACCD75205	105 (40)	70	65	10383 (22000)	2	4.4	1 5/8	1 5/8	290 (640)	14.6	7.7
ACCD75206	115 (46)	72	68	14819 (31400)	3	6.6	2 1/8	2 1/8	458 (1010)	25.8	13.6
ACCD75207	95 (35)	54	51	5711 (12100)	1	2.2	42	22	173 (381)	17.6	9.3
ACCD75208	105 (40)	57	54	11940 (25300)	2	4.4	42	28	307 (677)	27.1	14.3
ACCD75209	115 (46)	57	55	11374 (24100)	2	4.4	54	35	360 (792)	48.2	25.4

Specifications given for conditions at sea level.

## Fluid Coolers - Mechanical Data (ACRD200 Series)

SKU	Ambient Temp °C (°F)	Sound Pressure (dbA) at 10 ft and 100% Fan Speed	Air Quantity	Fan	Unit	Connection Size (inches)	Weight	Capacity	
			l/s (CFM)	Qty.	kW		Kg (Lbs)	MBH/1F TD	kW/1C TD
ACFC75210	40 (105)	68	4760 (10100)	2	2.0	1 3/8	205 (450)	3.20	1.69
ACFC75255	35 (95)	65	2380 (5050)	1	1.0	1 1/8	150 (330)	2.36	1.24
ACFC75256	35 (95)	62	4220 (8950)	2	1.6	1 1/2	90 (198)	2.50	1.32
ACFC75257	40 (105)	56	5500 (11650)	2	1.4	2	151 (333)	3.30	1.74

## Air Cooled Condensers - Electrical Data (ACRD100 Series)

SKU	Voltage Phase Frequency	FLA	MCA	MOP
ACCD75214	208-240V 1 ph 60 Hz	4.8	15	15
ACCD75215	208-240V 1 ph 60 Hz	4.8	15	15
ACCD75216	380-415V 3 ph 50 Hz	1.35	N/A	N/A
ACCD75217	380-415V 3 ph 50 Hz	2.7	N/A	N/A
ACCD75218	220-240V 1 ph 50 Hz	3.0	N/A	N/A
ACCD75219	220-240V 1 ph 50 Hz	6.0	N/A	N/A

FLA=Full Load Amps  
MCA=Minimum Circuit Amperes  
MOP=Maximum Overcurrent Protection

## Air Cooled Condensers - Electrical Data (ACRD500 Series)

SKU	Voltage Phase Frequency	FLA	MCA	MOP
ACCD75201	208-230V 3 ph 60 Hz	7.0	15.0	25
ACCD75202	208-230V 3 ph 60 Hz	14.0	20.0	35
ACCD75203	208-230V 3 ph 60 Hz	21.0	22.8	40
ACCD75204	460V 3 ph 60 Hz	3.5	15.0	15
ACCD75205	460V 3 ph 60 Hz	7.0	15.0	15
ACCD75206	460V 3 ph 60 Hz	10.5	15.0	20
ACCD75207	400V 3 ph 50 Hz	3.1	N/A	N/A
ACCD75208	400V 3 ph 50 Hz	6.2	N/A	N/A
ACCD75209	400V 3 ph 50 Hz	6.2	N/A	N/A

FLA=Full Load Amps  
MCA=Minimum Circuit Amperes  
MOP=Maximum Overcurrent Protection

## Fluid Coolers - Electrical Data (ACRD200 Series)

SKU	Voltage Phase Frequency	FLA	MCA	MOP
ACFC75210	460V 3 ph 60 Hz	2.6	15	15
ACFC75255	480V 3 ph 60 Hz	1.3	15	15
ACFC75256	380-415V 3 ph 50 Hz	2.7	N/A	N/A
ACFC75257	380-415V 3 ph 50 Hz	2.7	N/A	N/A

FLA=Full Load Amps  
MCA=Minimum Circuit Amperes  
MOP=Maximum Overcurrent Protection



### ACCD75201 and ACCD75204

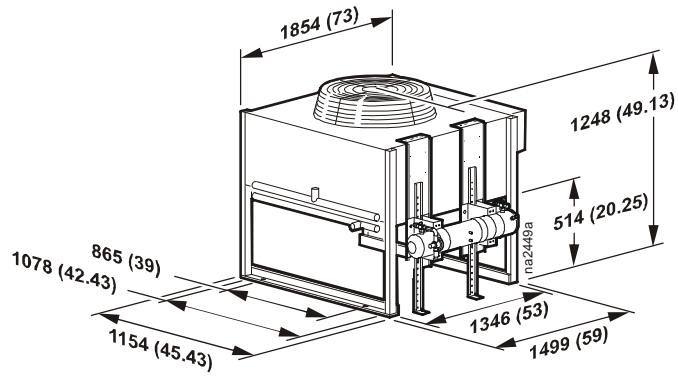

### ACCD75202 and ACCD75205

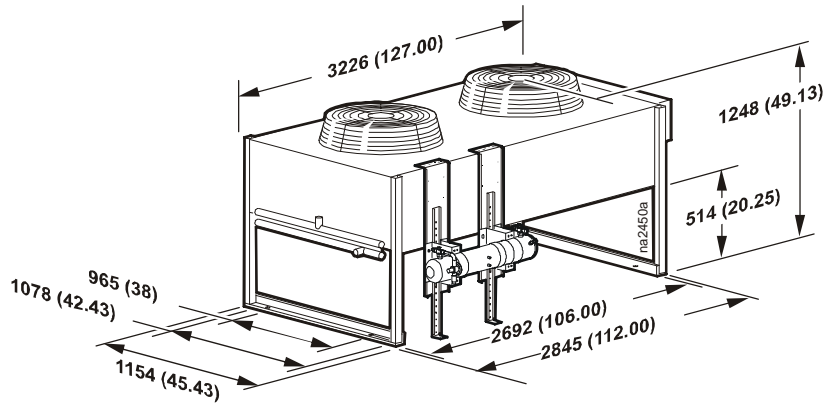

### ACCD75203 and ACCD75206

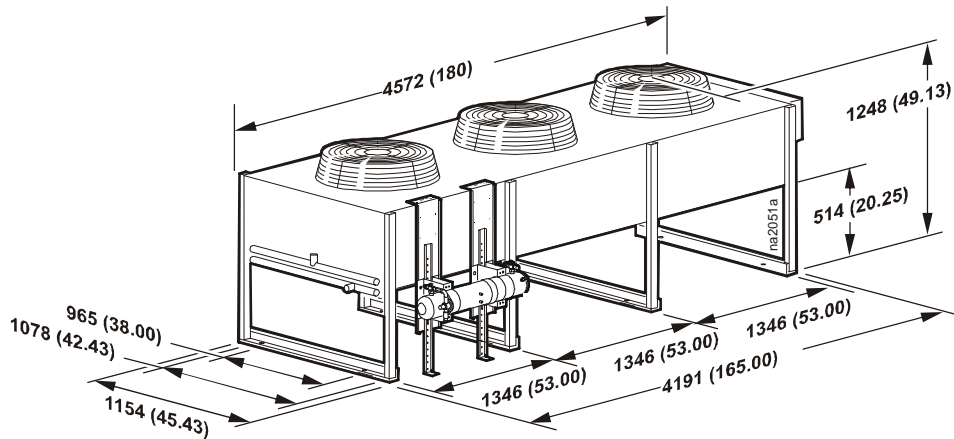

Dimensions are shown in mm (in).  
 All condensers shown on this page have eight 22 mm (0.875 in) mounting holes on their lower rails.

## ACCD75207

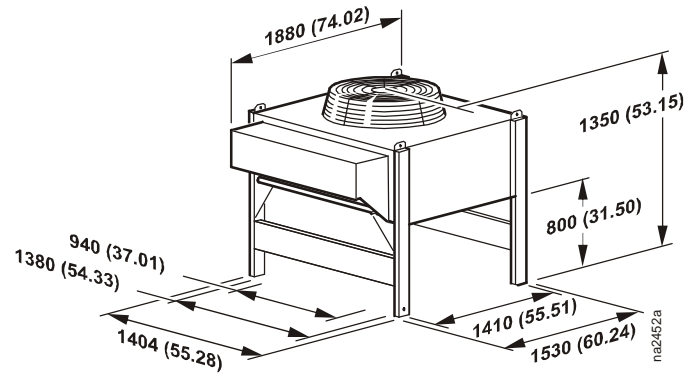

## ACCD75208 and ACCD75209

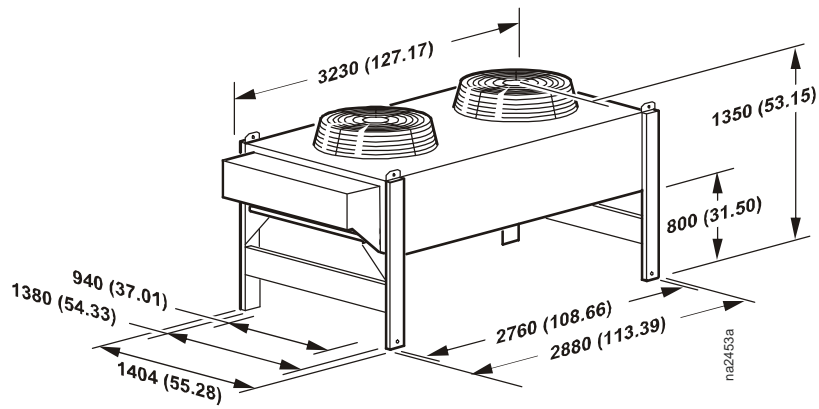

Dimensions are shown in mm (in).

All condensers shown on this page have 16 mm (0.63 in) mounting holes on each of their lower legs.

**ACCD75214**

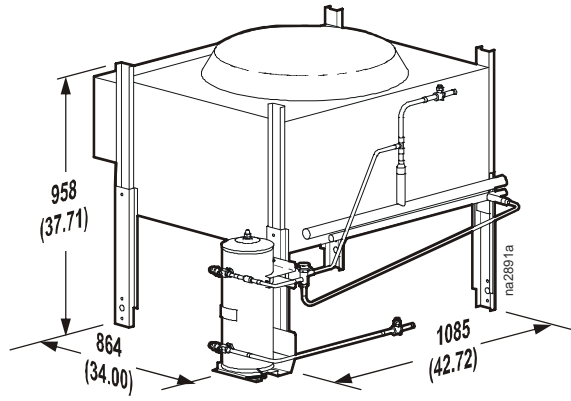

**ACCD75215**

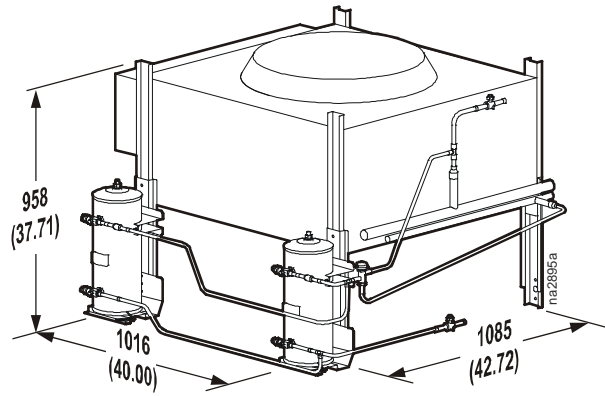

**ACCD75216 and ACCD75218**

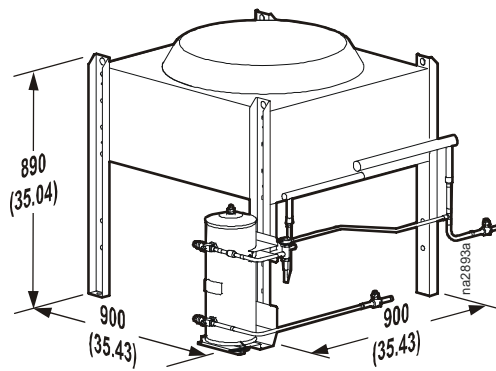

Dimensions are shown in mm (in).

**ACCD75217 and ACCD75219**

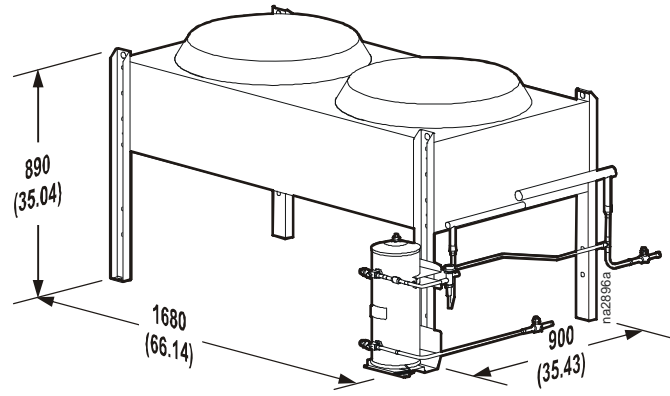

**ACFC75210**

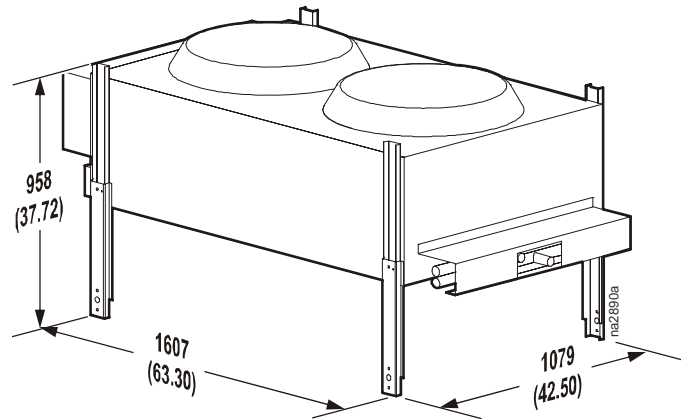

**ACFC75255**

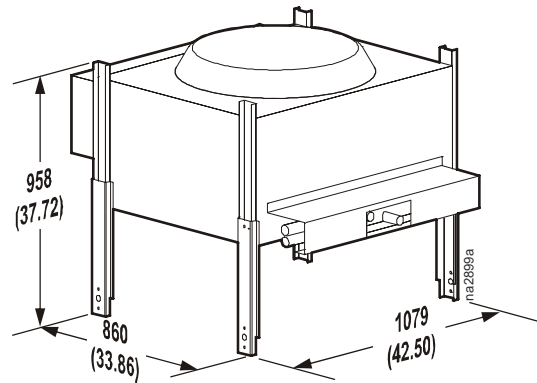

Dimensions are shown in mm (in).

## ACFC75256

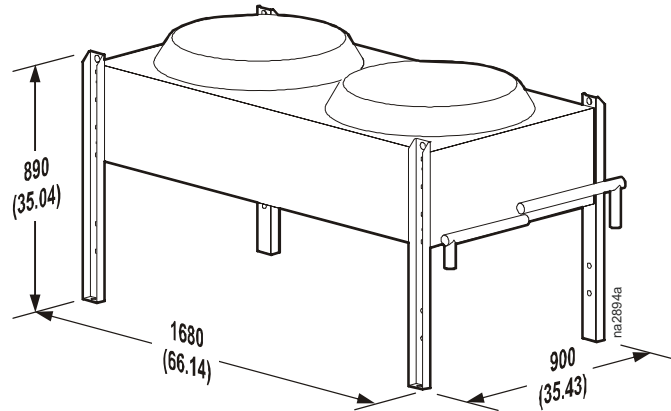

Dimensions are shown in mm (in).

## ACFC75257

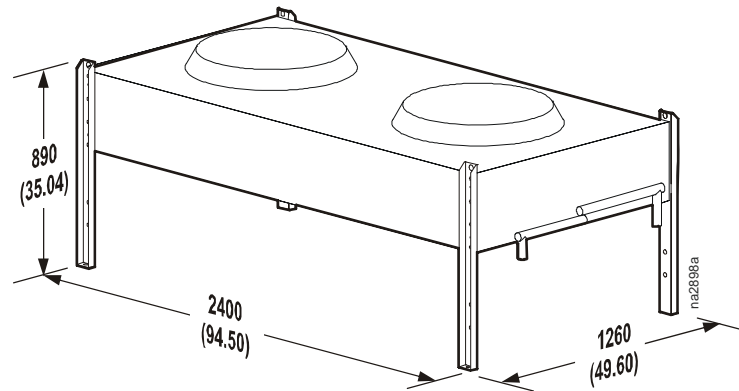

Dimensions are shown in mm (in).

### Air-cooled Condenser Features

Available in one to three fan configurations, APC offers air-cooled condensers with a vertical air discharge pattern. The RD500 series condensers utilize variable speed EC motor technology for improved sound and energy performance. All other condensers utilize variable speed motors.

60 Hz specific features:

- Side access panels for ease of cleaning coil
- Constructed with aluminum housing
- Weatherproof control panel with a factory-mounted door interrupt disconnect switch

50 Hz specific features:

- Constructed with painted galvanized steel



**Note:** A disconnect should be field-supplied based on maximum overcurrent protection (MOP) numbers.

# Guide Specifications

---

## PART 1 — GENERAL

### 1.01 SUMMARY

- A. The environmental control system shall be designed specifically for precision temperature control applications. It will automatically monitor and control cooling and filtering functions for the conditioned space. The system shall be built to the highest quality engineering and manufacturing standards, and shall be floor mounted and configured for horizontal airflow, with draw-through air pattern, to provide uniform air distribution over the entire face of the coil.

### 1.02 DESIGN REQUIREMENTS

- A. The system shall be as described in the following specification as manufactured by APC.
  - 1. Model: \_\_\_\_\_.
  - 2. Total net cooling capacity: \_\_\_\_\_ kW (MBH).
  - 3. Sensible net cooling capacity: \_\_\_\_\_ kW (MBH).
  - 4. Return air dry bulb temperature: \_\_\_\_\_ °C (°F) DB.
  - 5. Return air wet bulb temperature: \_\_\_\_\_ °C (°F) WB.
  - 6. Humidity: \_\_\_\_\_ % RH.
  - 7. Air volume: \_\_\_\_\_ L/s (CFM).
  - 8. Electrical supply: \_\_\_\_\_ V, \_\_\_\_\_ Hz.

### 1.03 SUBMITTALS

- A. Submittals shall be provided with the proposal and shall include: capacity data, electrical data, physical data, electrical connection drawing, and piping connection drawing.

### 1.04 QUALITY ASSURANCE

- A. The system shall be completely factory-tested prior to shipment. Testing shall include, but not be limited to: complete pressure and leak testing to ensure system integrity, dielectric withstand test, and controls calibration and settings. Each system shall ship with a completed test report to verify completion of factory testing procedure. The system shall be NRTL listed, MCA, and the electrical system shall be UL Listed to UL 1995 and CSA 22.2 No. 236.

### 1.05 WARRANTY

- A. System parts shall be warranted for a period of 18 months from date of shipment and 12 months from startup.

## PART 2 — PRODUCT

### 2.01 STANDARD COMPONENTS

#### A. Cabinet Construction

1. Front and rear exterior panels shall be 18 gauge perforated steel with 69.5% open free area, and equipped with a keyed lock to provide a means of securing access to the internal components of the unit.
  - a. ACRD100 and ACRD200 series only: Exterior panels shall be 18 gauge steel with  $80 \text{ kg/m}^3$  ( $5 \text{ lb/ft}^3$ ) density foam insulation. Insulation complies with UL94-5VA ASTM E84 flame spread and smoke developed rating of 25/50.
2. The frame shall be constructed of 16 gauge formed steel welded for maximum strength. All units shall provide maintenance from the front and rear, allowing units to be placed within a row of racks.
3. All exterior panels and frame shall be powder coated for durability and attractive finish. Exterior frame and panel color shall have color values: L = 74.50, a = -0.53, b = +8.20.
4. Units shall include casters and leveling feet to allow ease of installation in the row and provide a means to level the equipment with adjacent IT racks.

#### B. Fans

1. Variable speed direct drive mixed flow DC fan assembly (ACRD100 and ACRD200 series):
  - a. The unit shall be configured for draw-through air pattern to provide uniform air flow over the entire face of the coil. Each unit shall include six 200 mm mixed flow direct drive DC axial fans. Each fan assembly should be designed to provide 180.1 l/s (381.7 CFM) for total unit airflow of 1080.76 l/s (2290 CFM). The ACRD500 series includes two fans. Each fan provides 1085.5 l/s (2300 CFM) for a total unit airflow of 2171 l/s (4600 CFM).
  - b. Variable speed fans: Fans shall be variable speed capable of modulating from 30-100%. Fans shall soft start to minimize in-rush current.
  - c. Fan protection: Each fan assembly shall consist of a plastic injection molded bezel with integral fan discharge finger guard. Inlet of the fan should include a cage type finger guard.
  - d. Operation and service: The unit should be capable of operation in the event of a fan failure. Fans shall be replaceable while the unit is in operation.
2. Variable speed fan assembly (ACRD500 series):
  - a. Variable speed fans: The unit is equipped with two variable speed, electronically commutated, 400-mm backward incline fans complete with inlet volute.
  - b. Fan protection: discharge finger guard. Outlet of the fan should include a cage type finger guard.
  - c. Operation and service: The unit should be capable of operation in the event of a fan failure.

### C. Main Disconnect Switch

1. The unit shall be provided with thermal-magnetic circuit breakers with interrupt capacity ratings per UL489/CSA C22.2/IEC-947.

<b>Voltage</b>	<b>kAIC</b>
200-240V 50/60Hz	50
380-415V 50Hz	36
460-480V 60Hz	22

2. Units shall include a main disconnect switch located on the electrical panel in order to disconnect the power input.
3. A condenser disconnect shall be field-supplied.

### D. Microprocessor Controller

1. **Monitoring and configuration:** The display interface shall allow monitoring and configuration of the air conditioning unit through a menu-based control. Functions include status reporting, set-up, and temperature set points. Four LEDs report the operational status of the connected air conditioning unit.
2. **Controls:** The microprocessor controller shall come equipped with control keys to allow the user to navigate between menus, select items, and input alpha numeric information.
3. **Alarms:** The microprocessor controller shall activate a visible and audible alarm in the occurrence of the following events:
  - a. Cool Fail
  - b. Air filter clogged
  - c. Return air sensor fault
  - d. Supply air sensor fault
  - e. Rack temperature sensor fault
  - f. High discharge pressure
  - g. Low suction pressure
  - h. Fan fault
  - i. Water detected
  - j. Condensate pump fault
  - k. Air filter run hours violation
  - l. Group communication fault
  - m. Supply air high temperature violation
  - n. Return air high temperature violation
  - o. Filter DP sensor failure
  - p. Suction pressure sensor failure
  - q. Discharge pressure sensor failure
  - r. Persistent high discharge pressure fault
  - s. Rack inlet temperature high violation
  - t. External communication fault



- u. Internal communication fault
  - v. On standby input contact fault
  - w. A-link isolation relay fault
  - x. Excessive compressor cycling
  - y. Condensate pan full (ACRD100 series and ACRD200 series only)
  - z. Upper fan power supply fault (ACRD100 series and ACRD200 series only)
  - aa. Lower fan power supply fault (ACRD100 series and ACRD200 series only)
  - ab. Suction temperature sensor failure (ACRD100 series and ACRD200 series only)
  - ac. Persistent low suction pressure fault (ACRD100 series and ACRD200 series only)
  - ad. Condenser fluid valve actuator fault (ACRD200 series only)
  - ae. Outdoor heat exchanger fault (ACRD200 series only)
  - af. Factory configuration not completed (ACRD200 series only)
  - ag. Liquid refrigerant sensor failure (ACRD200 series only)
  - ah. Compressor drive communication fault (ACRD500 series only)
  - ai. Compressor drive fault (ACRD500 series only)
  - aj. Compressor drive warning (ACRD500 series only)
  - ak. Compressor run hours violation (ACRD500 series only)
  - al. Condensate pump run hours violation (ACRD500 series only)
  - am. Fan run hours violation (ACRD500 series only)
  - an. Supply humidity sensor fault (ACRD500 series only)
  - ao. High suction pressure
4. Logging: The microprocessor controller shall log and display all available events. Each alarm log shall contain time/date stamp as well as operating conditions at the time of occurrence. The controller shall display the run time hours for major components.

#### E. Network Management Card

The unit shall include a Network Management Card to provide management through a computer network through TCP/IP. Management through the network should include the ability to change set points as well as view and clear alarms.

## F. Cooling Coil And Condensate Pan

1. ACRD100 and ACRD200 series:
  - a. The cooling coil shall use corrugated aluminum fin and copper tube coils. The coil header is equipped with a drip plate in the bottom to capture and direct the condensation accumulating on the suction header tube to the drain pan.
2. ACRD500 series:
  - a. The cooling coil shall use raised lance type corrugated aluminum fin and 12.7-mm (1/2-in) OD copper tube coils. Fin shall be a minimum of 0.0055 in thick. Tube wall shall be a minimum of 0.016 in thick. Coil end supports shall be a minimum 18 gauge G90 galvanized steel. The coil shall be rated for a maximum pressure of 3447.3 kPa (500 psig) or higher, and the coils are certified in accordance with UL207. The coil header is equipped with a drip plate in the bottom to capture and direct the condensation accumulating on the suction header tube to the drain pan.

## G. Compressor

1. SCROLL COMPRESSOR (ACRD100 series and ACRD200 series only)
  - a. The high EER (up to 20.0) and few moving parts of scroll compressors shall provide efficient and reliable operation. Scroll technology has unparalleled ability to withstand liquid refrigerant ‘slugging’ which is a major cause of compressor failure.
2. VARIABLE SPEED / VFD ASSEMBLY (ACRD500 series only)
  - a. Compressor: The unit shall be configured with a variable speed reciprocating hermetic compressor using a matched VFD. As a result, the compressor speed can be varied through a range between 30 and 85 Hz to accommodate varying load conditions. VFD firmware is written to include oil return protection in cases where pipe velocities may drop to low speeds during low loading periods.
  - b. Compressor is electrically protected through the VFD.
  - c. Compressor utilizes a sound jacket for noise reduction.
  - d. A sight glass is provided for air cooled system oil charging.

## H. Condensate Pump

1. ACRD100 series and ACRD200 series: Dual factory installed and wired condensate pumps shall pump at 9.8 l/h (2.6 g/hr) at 4.9 m (16 ft) of head. Each pump shall have dual internal floats.
2. ACRD500 series: A single factory installed and wired condensate pump shall pump at 11.8 l/h (8.45 g/hr) at 3.5 m (11.5 ft) of head. The pump shall have dual internal floats.
3. Each pump shall have a condensate reservoir made of polymeric materials to prevent corrosion.

## I. Filters

1. ACRD100 series and ACRD200 series:
  - a. The standard filters shall be 20% efficient per ASHRAE 52.1, MERV 1 per ASHRAE 52.2, 1/2 in washable mesh filter.
  - b. The optional filter shall be high capacity 2 in pleated, UL 900 Class 2, moisture resistant, with average atmospheric dust spot efficiency of 30%, per AHRAE Standard 52.1, MERV 8 per ASHRAE 52.2.
2. ACRD500 series:
  - a. The standard pleated filters shall be 96mm (3.75in) deep, and 30% efficient per ASHRAE Standard 52.1, UL Class 2 (MERV 8 per ASHRAE 52.2). Filters shall be EN779 G4 efficient.
  - b. The optional filter shall be 85% efficient per ASHRAE Standard 52.1 (MERV 13 per ASHRAE 52.2, EN779 F7).

## J. Temperature Sensors

1. Internal Temperature Sensors: Thermistor temperature sensors shall be mounted behind the front and rear doors to provide control inputs based on supply and return air temperature. Sensor accuracy shall be within  $\pm 1$  degree F accuracy.
2. Remote Temperature Sensors
  - a. ACRD500 series: Three remote rack inlet temperature sensors shall be shipped with the unit to provide control input based on rack inlet temperature.
  - b. ACRD100 and ACRD200 series: One remote rack inlet temperature sensor shall be shipped with the unit to provide control input based on rack inlet temperature.

## K. Selectable Top Or Bottom Piping (ACRD500 Series)

1. Pipe connections: The unit is equipped to facilitate field connections from either the top or bottom. Unit connections shall be made internal to the unit.
2. Pipe adapter: The unit shall include two pipe adapters that convert a 31.75-mm (1 1/4-in) NPT to a 31.75-mm (1 1/4-in) BSPT (manufactured in accordance with BS21). Pipe adapters shall ship loose with the unit for field installation where applicable.

## L. Cable Water Detector (Optional)

1. The optional leak detection sensing cable shall be shipped loose with the unit. If water or other conductive liquids contact the cable anywhere along its length, the main controller visually and audibly annunciates the leak.
2. The optional detector shall be provided with 6.1 m (20 ft) of cable. Cable may be cascaded up to 24.4 m (80 ft).

## M. Bridge Power Cable Trough

1. An overhead power distribution bridge, that sits between adjacent NetShelter racks and allows for removal of the unit without disrupting the overhead power cabling, is available as an accessory.
2. Cable trough shall be constructed of 16 gauge cold rolled steel with a black powder coat finish.

N. Bridge Data Partition

1. An overhead cable distribution, that sits between adjacent NetShelter racks and allows for removal of the unit without disrupting overhead cabling, is available as an accessory.
2. Data partition shall be constructed of 16 gauge cold rolled steel with a black powder coat finish.

O. Cooling Fluids (ACRD200 Series)

Water and solutions of propylene or ethylene glycol up to 50% may be used. Solutions of brine or other aqueous salt are NOT permitted.

P. Freeze Protection (ACRD200 Series)

Per ASHRAE Handbook Fundamentals 2001 21.5, a maximum of 30% ethylene glycol and 35% propylene glycol are needed for freeze protection. See the ASHRAE handbook for more details.

# Guidelines for Installation

The InRow RD provides reliable, accurate temperature control of computer rooms, laboratories, and other environments that require close tolerance control. The unit incorporates the latest system design innovations to provide you with optimum efficiency, reliability, and accuracy of control.

The InRow RD unit will provide years of trouble-free service when installed and maintained by technically qualified personnel. For more detailed information, see the appropriate InRow RD Installation manual:

ACRD100 series: 990-3211

ACRD200 series: 990-3213

ACRD500 series: 990-3235

## Room preparation

During the design of the room, consideration should be given to the following factors: ease of entry for the system, floor-loading factors, and accessibility of piping and wiring.

The room must be sealed with a vapor barrier to minimize moisture infiltration. Polyethylene film (plastic sheeting) is a good vapor barrier for ceiling and wall applications. Rubber- or plastic-based paints should be applied to concrete floors and walls. The room should be thoroughly insulated to minimize thermal loads and make-up air (if required) should be preconditioned to reduce additional temperature, filtration, and moisture loads.

## Service access

For routine service while in the row, at least 914.4 mm (36 in) of clear space must be left in the front and rear of the unit. To move the equipment outside the row for service, an area of 1219 mm (48 in) of clear space is required.

## Receiving the unit

Your InRow RD unit has been completely tested and inspected prior to shipment. To ensure that you have received the unit in excellent condition, perform a careful inspection of the crating and the unit immediately upon receipt. Verify that all parts ordered were received as specified and that the unit is the correct size and voltage necessary to fulfill your environmental control needs. Report any damage discovered to the freight carrier. If necessary, contact the APC field service department for help in repairing or replacing damaged parts. While APC is not responsible for damage incurred in transit, we want to make sure that you have no undue delays in your system start-up. See the unpacking sheet and installation manual for more information.

## Rigging

The unit is manufactured with a formed steel frame for maximum strength and unit integrity. However, as with all electrical and mechanical equipment, you must take care with proper rigging of your unit.

When using a forklift to move the unit, use the shipping skid to protect the bottom of the unit. When using chains, cables, or rope to lift the unit, use spreader bars to prevent damage to the finished panels. Four threaded M10X16 holes are provided in the top of the frame to accommodate lifting eye bolts that can be utilized to lift the unit.

## Condensate drain

Condensation from the evaporator pan is collected and discharged by the condensate pump to a condensate line supplied with the unit. Additional condensate piping is required to route to the building condensate system.



**Note:** Because of an ongoing program dedicated to product improvement, specifications are subject to revisions without notice. APC assumes no responsibility, and disclaims all liability for damages resulting from use of this information or for any errors or omissions.



# APC Worldwide Customer Support

Customer support for this or any other APC product is available at no charge in any of the following ways:

- Visit the APC Web site to access documents in the APC Knowledge Base and to submit customer support requests.
  - **www.apc.com** (Corporate Headquarters)  
Connect to localized APC Web sites for specific countries, each of which provides customer support information.
  - **www.apc.com/support/**  
Global support searching APC Knowledge Base and using e-support.
- Contact an APC Customer Support center by telephone or e-mail.
  - Regional centers

Direct InfraStruXure Customer Support Line	(1)(877)537-0607 (toll free)
APC headquarters U.S., Canada	(1)(800)800-4272 (toll free)
Latin America	(1)(401)789-5735 (USA)
Europe, Middle East, Africa	(353)(91)702000 (Ireland)
Western Europe (including Scandinavia)	+800 0272 0272
Japan	(0) 36402-2001
Australia	1(800) 652 725 (toll free)
New Zealand	0 (800) 333 373 (toll free)

- Local, country-specific centers: go to **www.apc.com/support/contact** for contact information.

Contact the APC representative or other distributor from whom you purchased your APC product for information on how to obtain local customer support.

Entire contents copyright 2008 American Power Conversion Corporation. All rights reserved. Reproduction in whole or in part without permission is prohibited. APC, the APC logo, InRow, and NetShelter are trademarks of American Power Conversion Corporation. All other trademarks, product names, and corporate names are the property of their respective owners and are used for informational purposes only.

