

**IMPORTANT NOTICE**

Astec Projects Ltd claims proprietary rights to the information disclosed herein. This drawing is furnished in confidence on the express understanding that neither it or any reproduction thereof will be disclosed to others or use for the purpose of manufacture or procurement of the article or part shown herein without the express consent in writing of Astec Projects Ltd. It should be understood that any article or part made in accordance with the attached drawing or copied from an article or part made in accordance with said drawing, without the express permission in writing of Astec Projects Ltd will be an infringement of the copyright which subsists in said drawing and therefore actionable at law.  
© 2010 Astec Projects Limited

**DO NOT SCALE - IF IN DOUBT ASK**

**01** Typical vertical section thro' facade at slab edge (restraining bracket)  
1:20

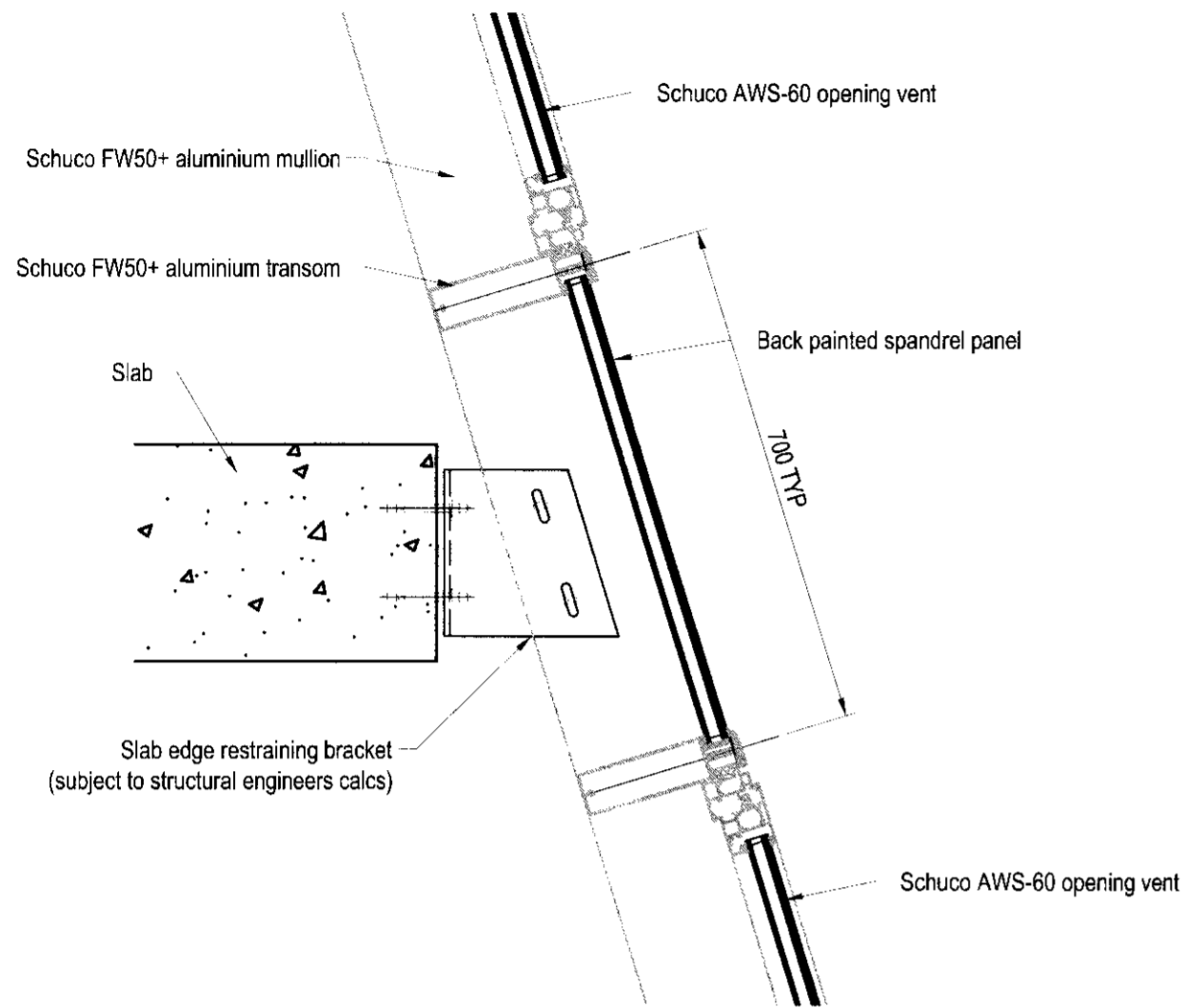

**02** Typical vertical section thro' facade at slab edge (support bracket)  
1:20

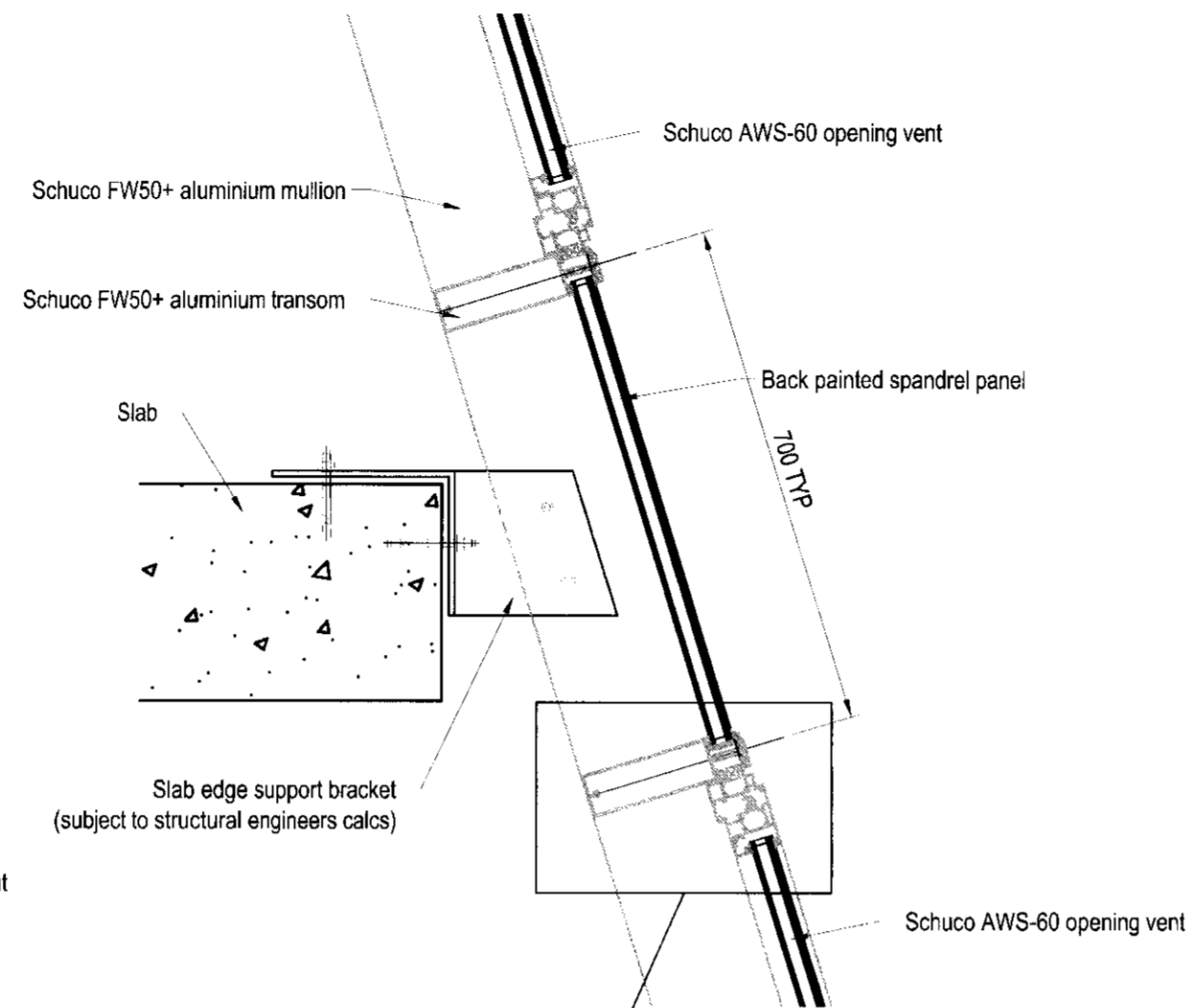

**04** Enlarged detail  
1:5

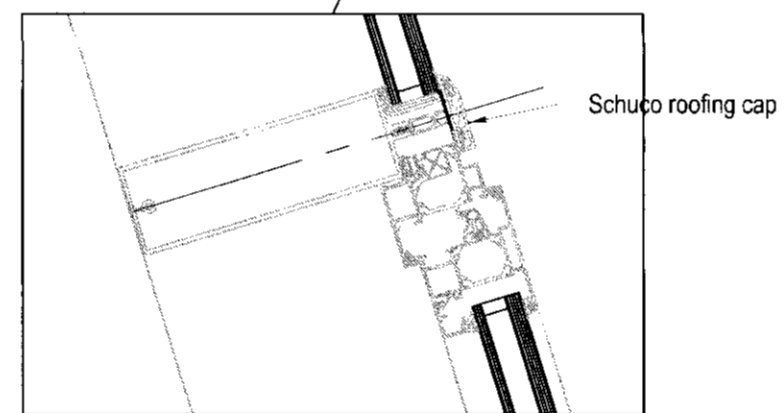

**03** Typical horizontal section thro' mullion at vents  
1:20

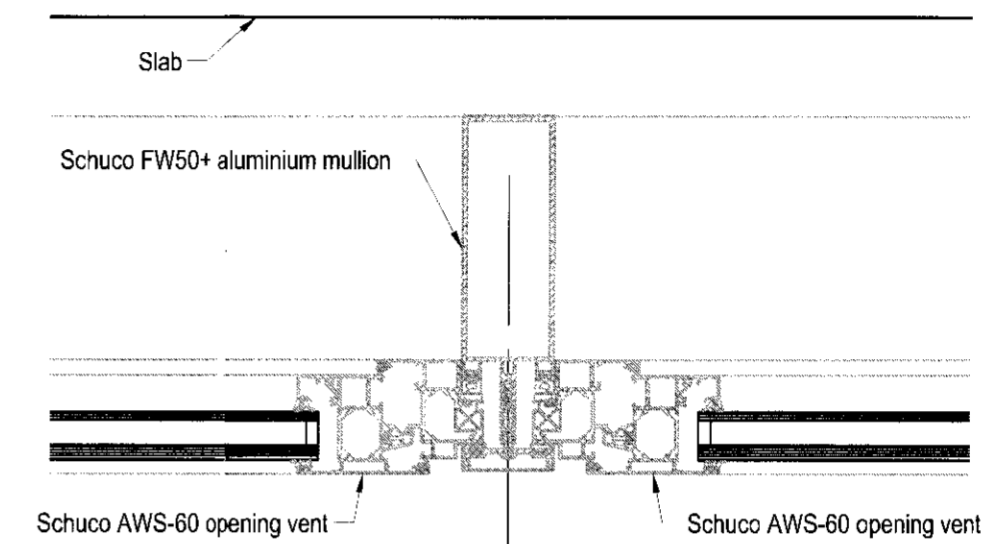

**05** Typical horizontal section thro' facade at spandrel panel  
1:20

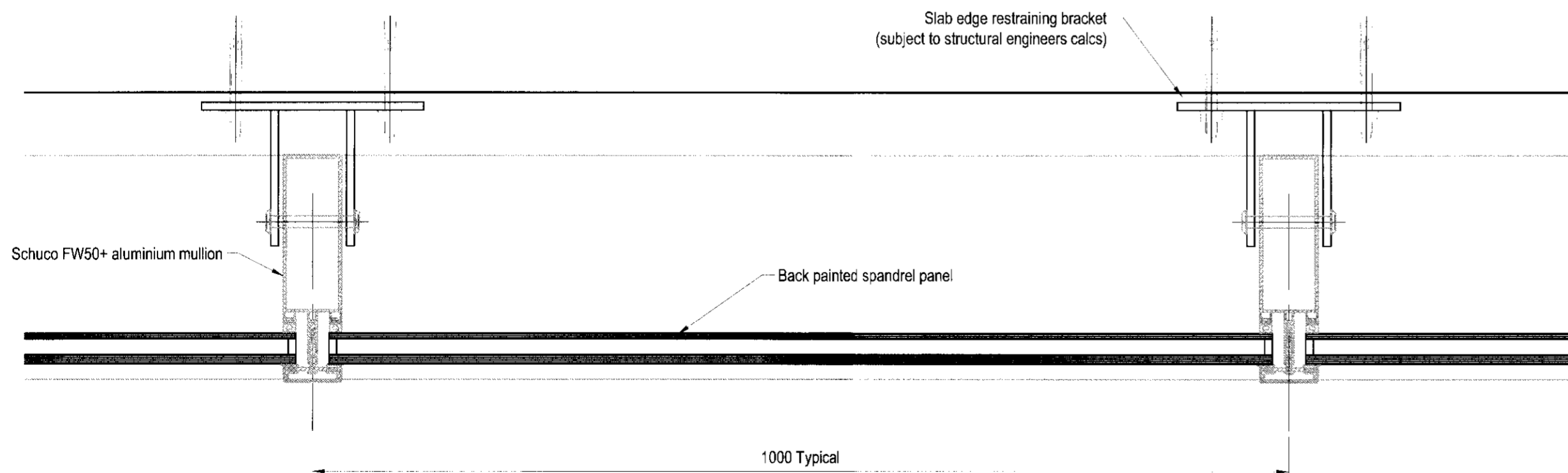

**06** Typical horizontal section thro' facade at support bracket  
1:20

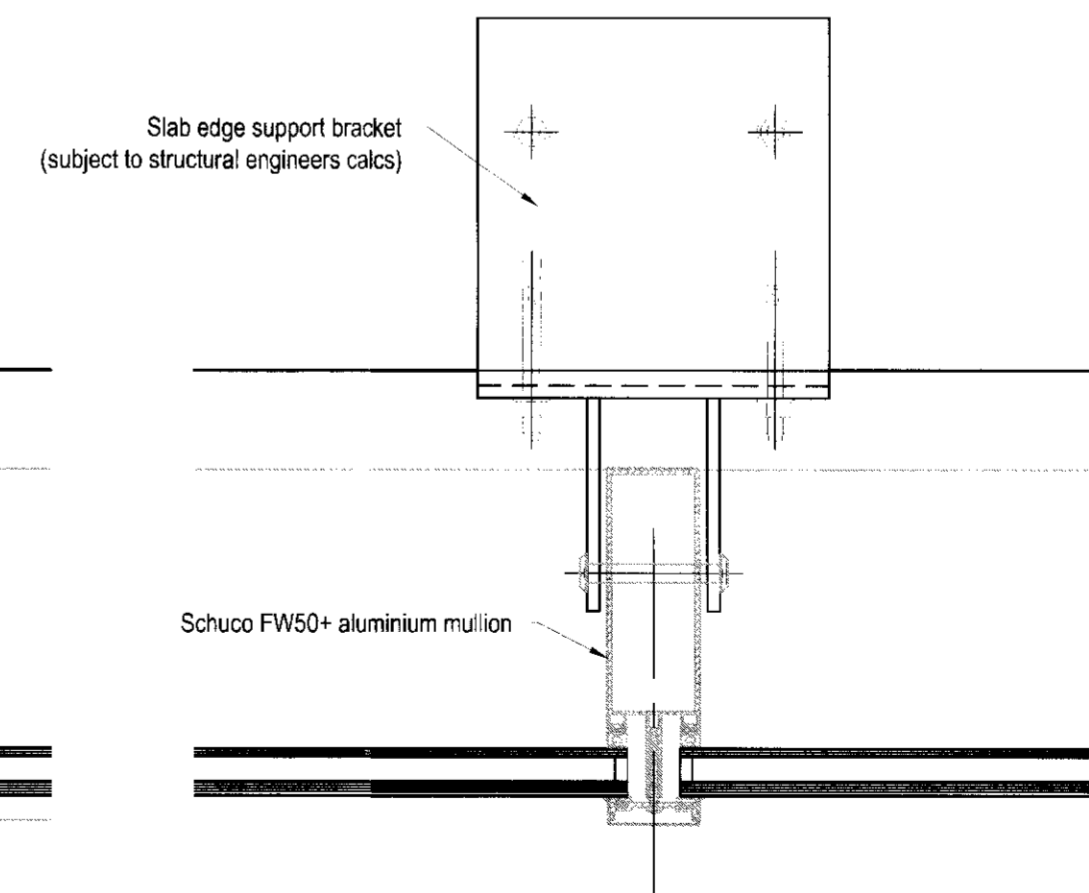

REV	DATE	DESCRIPTION	BY



**ASTEC PROJECTS LIMITED**  
Astec House, 187/189 Kings Road,  
Reading, Berkshire RG1 4EX  
Telephone: 0118 958 1333  
Facsimile: 0118 958 1347  
www.astecprojects.co.uk

**233 SHAFTESBURY AVENUE  
FACADE  
TYPICAL DETAILS**

SCALE	SHOWN	DATE	17.09.10	DRAWN BY	GPK
DRG No.	Q10BLL5490-1/SA/Q1000			CHECKED	DG
ISSUED FOR	REVIEW			REVISION	-
					ORIGINAL SIZE A2