

Signage Specification

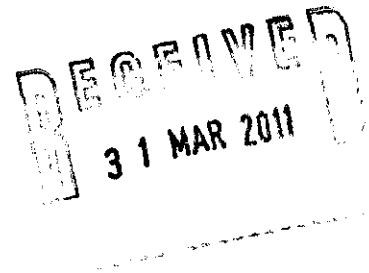
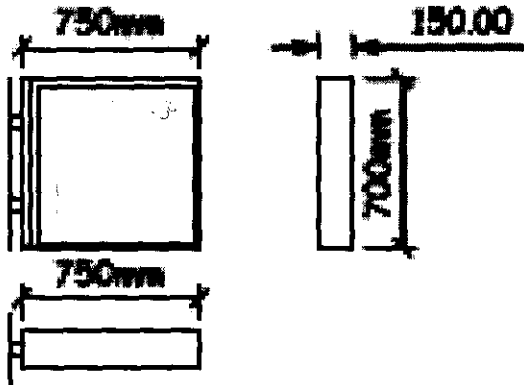

Projecting Sign

Sign case to be constructed from de scaled stainless steel, reinforced internally, etched primed and stave enamelled to match Blue matt finish with suitable projecting arm fixing decorated to match.

Sign case to be fitted with folded 14 gauge aluminium panel suitably etched primed and stave enamelled to match blue matt finish.

Panels to be stencil cut and fitted with text consisting of 6mm opal acrylic onto face of panel. Panel to be internally illuminated by rope of white MiriMAX LED complete with switch start control gear.

Luminance level shall be max 800 candela per sq' metre of area illuminated.

Fascia Sign

Folded aluminium back panels finished powder coat to match Ral 5002. "Jacobs" to be manufactured as built up flat faced de scaled stainless steel lettering powder coated white, complete with 50mm returns and 4mm opal mackrolon back trays, with internal led illumination to provide a halo effect around the lettering. Secondary lettering to be face applied fret cut vinyl lettering.

Luminance level shall be max 800 candela per sq' metre of area illuminated.