



Large Capacity Digital Inverter Twin, Triple & Double Twin Split Systems

- Allows connection of two, three or four indoor units of the same type
- Indoor units are in the same room, operate together and have a single remote controller **(ALL in the same MODE)**
- Ideal for larger shops and retail premises
- Outdoor unit 400V, 3 Phase Supply
- High Efficiency Twin Rotary Inverter Compressor
- Space Saving Small Footprint
- Light weight and Easy to Install
- Toshiba R22 & R407C 'Replace Technology'

This range of outdoor units has been designed to provide a high Capacity output from a very small footprint.

Powered by Toshiba's twin rotary compressor technology along with our inverter technology, these systems offer exceptionally high efficiency levels, long pipe runs and great flexibility for installation.

Ideal for large open spaces such as hotels foyers, restaurants, bars, gyms and retail premises.



Model

Outdoor Unit Large Capacity Digital Inverter

RAV

SM2244AT8-E

SM2804AT8-E

System Data

Cooling capacity range	kW	20 (9.8-22.4)	23 (9.8-27)
Heating capacity range	kW	22.4 (9.8-25.0)	28 (9.8-31.5)
UK Conditions Cooling **	kW	21.7	26.2
UK Conditions Sensible Cooling **	kW	15.2	17.8
UK Conditions Heating **	kW	14.0	17.4
Air Flow	m ³ /min	133	133
Sound Pressure Level, Cooling / Heating	db(A)	56 / 57	57 / 58
Sound Power Level, Cooling / Heating	db(A)	72 / 74	74 / 75
Dimensions, height, width, depth	H x W x D	1540 x 900 x 320	1540 x 900 x 320
Weight	kg	134	134
Operation Range. Cooling / heating	°C	-15 to 46 / -20 to 15	-15 to 46 / -20 to 15
Pipe Connections, gas - liquid	in	1 1/8" - 1.2"	1 1/8" - 1.2"
Pipe Length Maximum/pre-charged	m	70 / 30	70 / 30
Additional R410a charge	g/m	Refer to Manual	Refer to Manual
Maximum height difference, above/below	m	30 / 30	30 / 30
Max operating Current, cooling	A	18	22
Suggested Fuse Size	A	25	25
Power supply to outdoor unit	V-ph-HZ	400 - 3 - 50	400 - 3 - 50
Interconnecting cables		3 + E	3 + E

** UK Conditions are calculated and are approximations only

Data sheet 3 - page 2 of 2

RAV-SM2244AT8-E & RAV-SM2804AT8-E

Dimensions

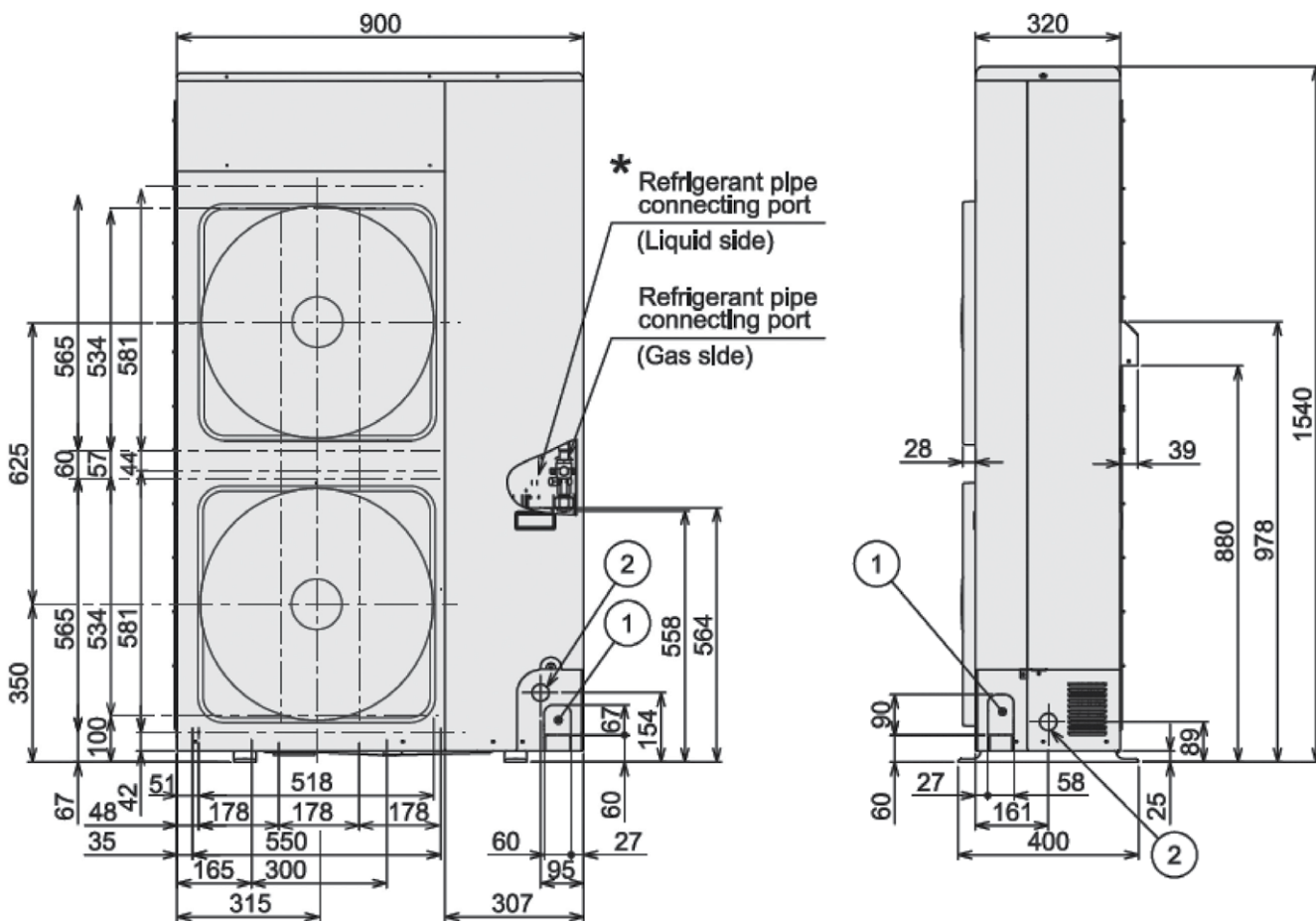

Combinations

	RAV-SM2244AT series	Branch kit
Twin (Simultaneous Same Mode Operation)	SM110 — SM110	RBC-TWP101E
Triple (Simultaneous Same Mode Operation)	SM80 — SM80 — SM80	RBC-TRP100E
Double-Twin (Simultaneous Same Mode Operation)	SM56 — SM56 — SM56 — SM56	RBC-DTWP101E

	RAV-SM2804AT series	Branch kit
Twin (Simultaneous Same Mode Operation)	SM140 — SM140	RBC-TWP101E
Triple (Simultaneous Same Mode Operation)	SM80 — SM80 — SM80	RBC-TRP100E
Double-Twin (Simultaneous Same Mode Operation)	SM80 — SM80 — SM80 — SM80	RBC-DTWP101E

Toshiba Carrier UK Ltd
 United Technologies House
 Guildford Road
 Leatherhead
 Surrey KT22 9UT

Marketing.uk@toshiba-ac.com
 www.toshiba-aircon.co.uk