

wall-Reform®

Solid Wall Insulation System

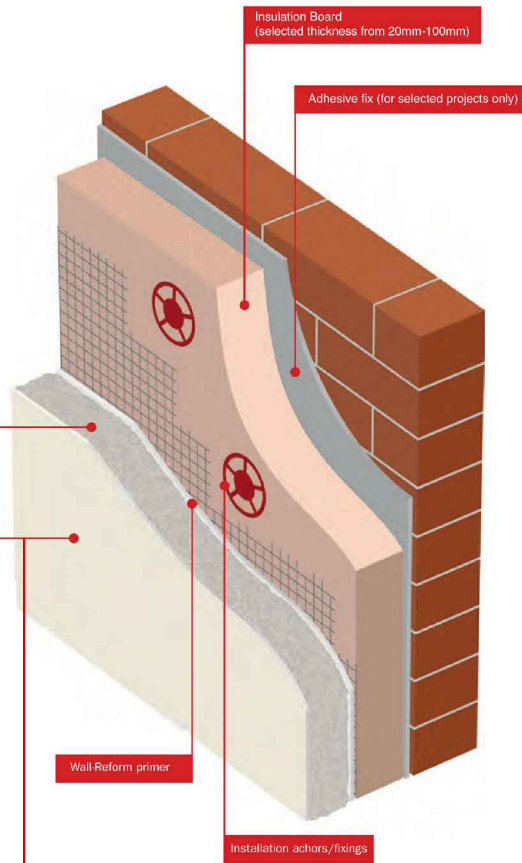

U-values Typical Construction Format for 215mm brickwork

Allowing for a consistent 15mm Wall-Reform and 2mm acrylic/silicone finish

Un-insulated: 2.10W/m².k

Resultant value with:

20mm EWb: 0.61 W/m ² .k	70mm EWb: 0.24 W/m ² .k
30mm EWb: 0.47 W/m ² .k	80mm EWb: 0.22 W/m ² .k
40mm EWb: 0.39 W/m ² .k	90mm EWb: 0.20 W/m ² .k
50mm EWb: 0.31 W/m ² .k	100mm EWb: 0.18 W/m ² .k
60mm EWb: 0.27 W/m ² .k	

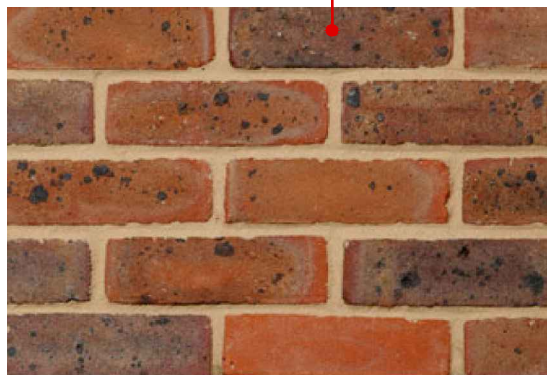

TYPICAL WINDOW

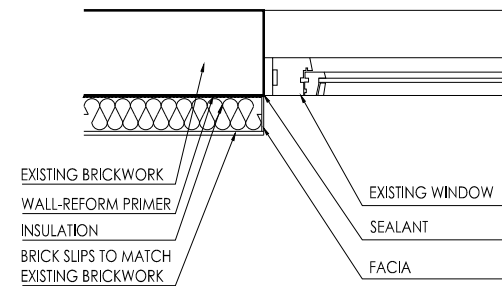

TYPICAL DOOR

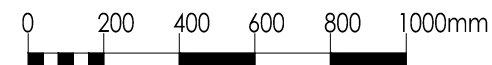
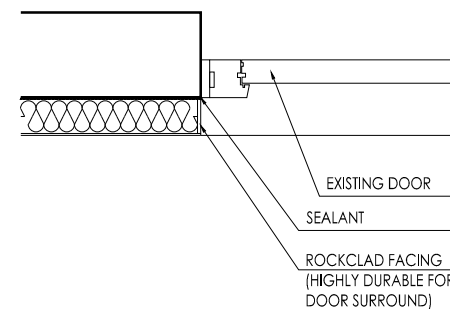

Amendments



DO NOT SCALE FOR CONSTRUCTION

brodie plant goodard

BUILDING SURVEYING
ARCHITECTURE
PROJECT MANAGEMENT
QUANTITY SURVEYING

HOLMBURY HOUSE
DORKING BUSINESS PARK
STATION ROAD, DORKING
SURREY RH4 1JU

T 01306 887070
F 01306 876716
admin@bpg.co.uk
www.bpg.co.uk

PROJECT
ORIGIN HOUSING - OVERCLADDING

CLIENT
ORIGIN HOUSING

DATE
APR 2011

DRAWN SD CHECKED RM

SCALE 1:20@A4 FOR 1:10@A2 PLANNING

TITLE
INSULATION SYSTEM & GENERAL DETAILS

DRAWING NO.
3346/DE00

REV

EXISTING

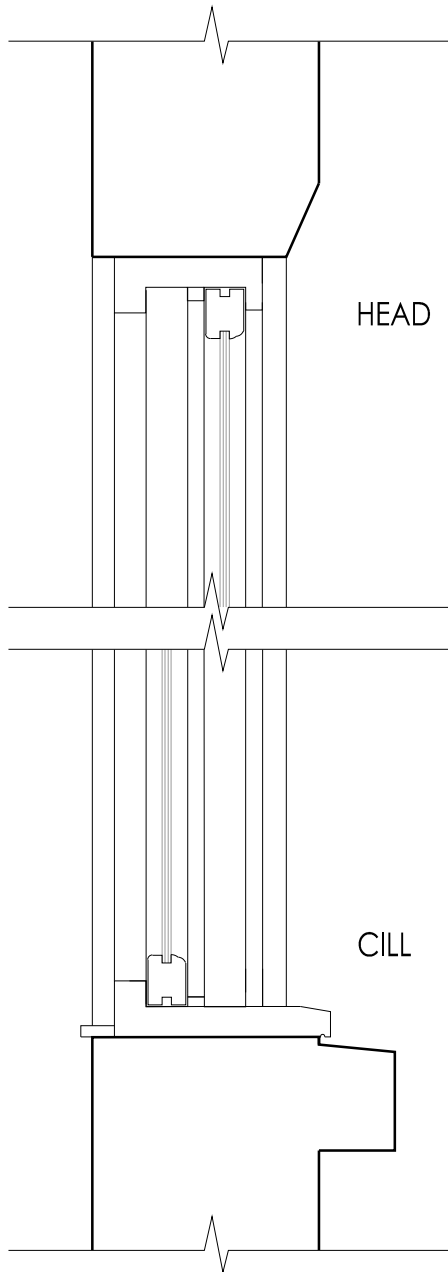

PROPOSED

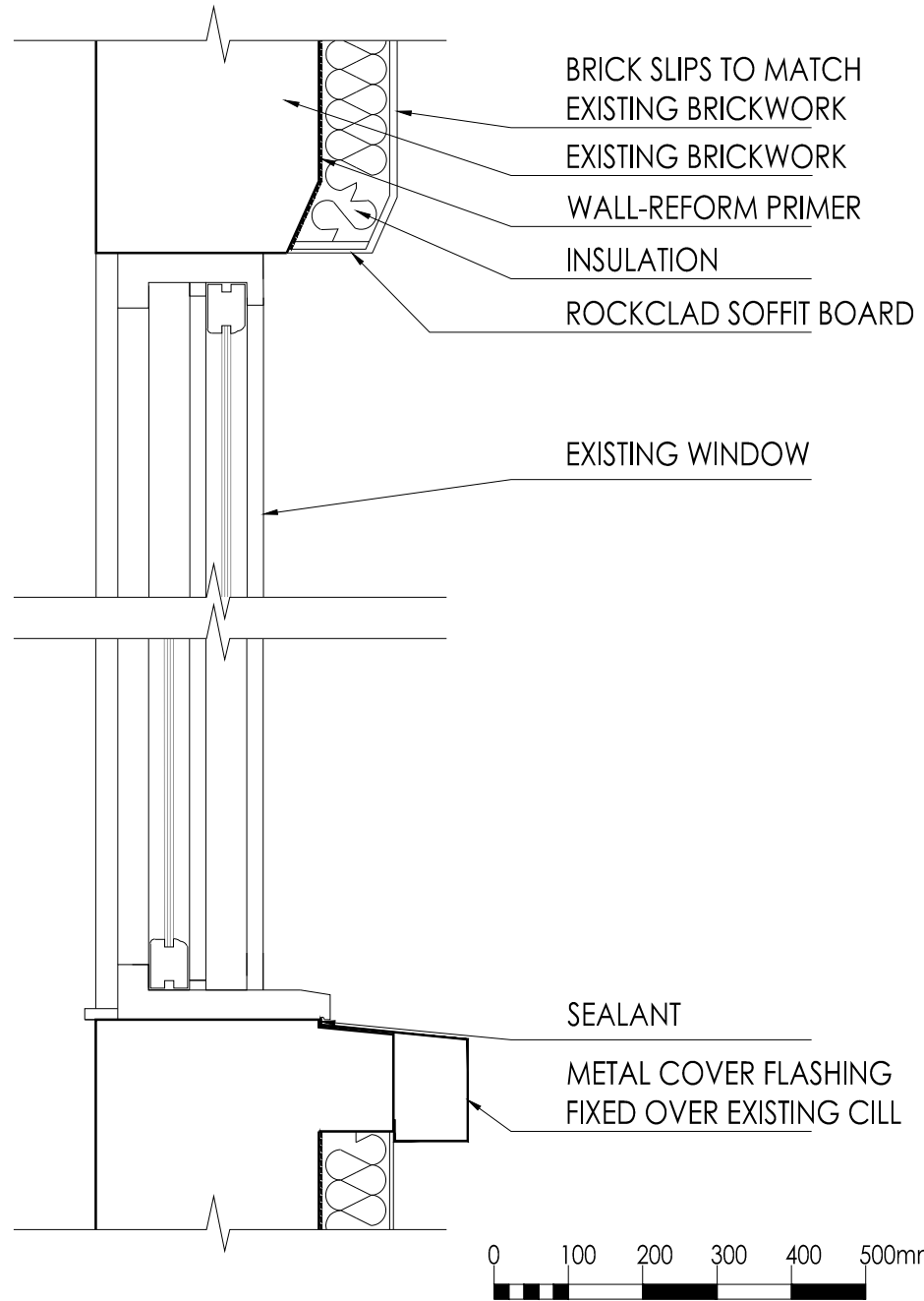

Amendments



DO NOT SCALE FOR CONSTRUCTION



BUILDING SURVEYING
ARCHITECTURE
PROJECT MANAGEMENT
QUANTITY SURVEYING

HOLMBURY HOUSE
DORKING BUSINESS PARK
STATION ROAD, DORKING
SURREY RH4 1HJ
T 01306 887070
F 01306 876716
admin@bpg.co.uk
www.bpg.co.uk

PROJECT
ORIGIN HOUSING -
OVERCLADDING

CLIENT
ORIGIN HOUSING

DATE
APR 2011

DRAWN SD CHECKED RM

SCALE 1:10@A4 FOR 1:5@A2 PLANNING

TITLE
DETAIL 1

DRAWING NO. 3346/DE01 REV *

EXISTING

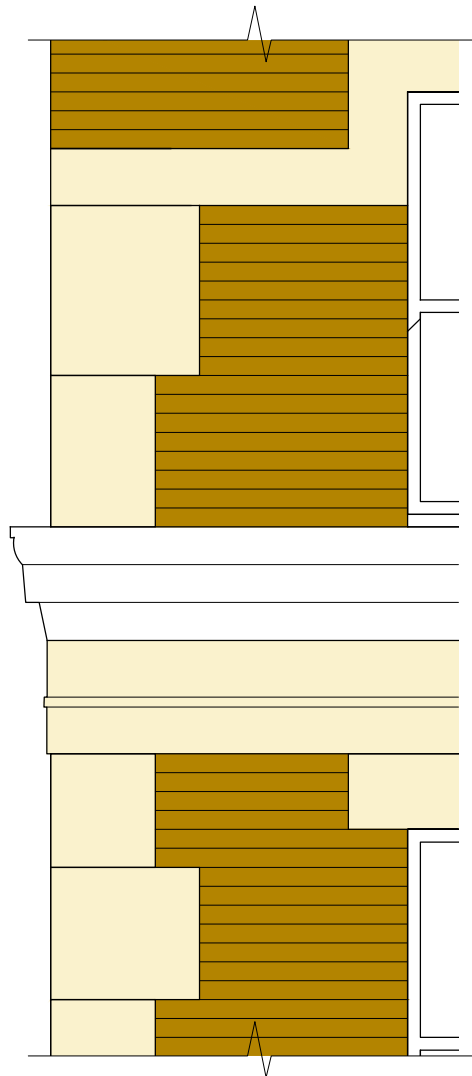

STONE SELF-COLOURED RENDER USED TO REPLICATE BANDING, WINDOW LINTELS & CORNER QUOINS

PROPOSED

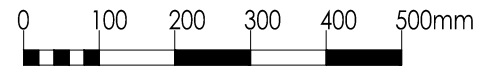
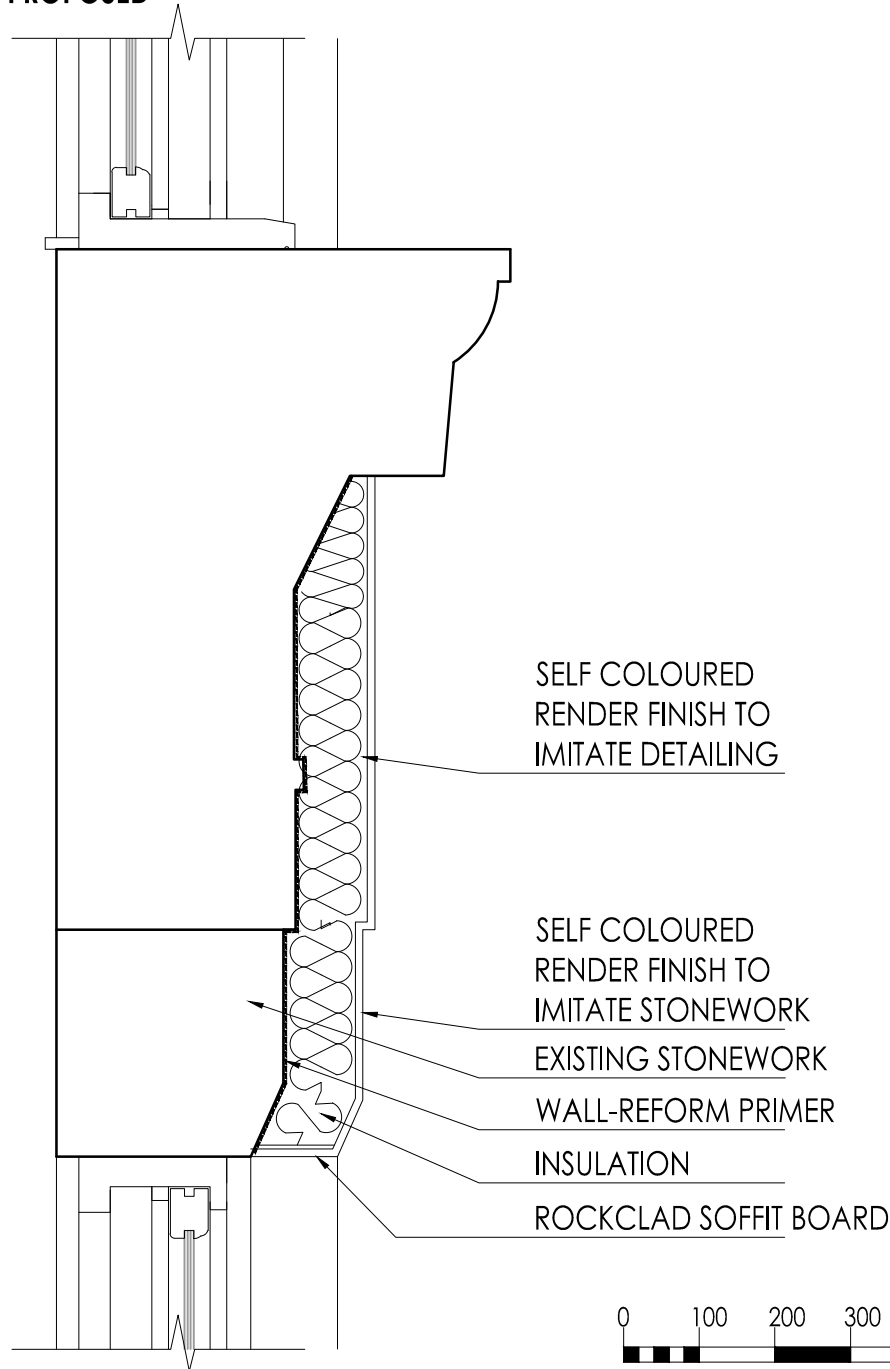

Amendments



DO NOT SCALE FOR CONSTRUCTION



BUILDING SURVEYING
ARCHITECTURE
PROJECT MANAGEMENT
QUANTITY SURVEYING

HOLMBURY HOUSE
DORKING BUSINESS PARK
STATION ROAD, DORKING
SURREY RH4 1HJ
T 01306 887070
F 01306 876716
admin@bpg.co.uk
www.bpg.co.uk

PROJECT
ORIGIN HOUSING -
OVERCLADDING

CLIENT
ORIGIN HOUSING

DATE
APR 2012

DRAWN SD CHECKED RM

SCALE 1:10@A4 FOR 1:5@A2 PLANNING

TITLE
DETAIL 2

DRAWING NO. 3346/DE02 REV *

EXISTING

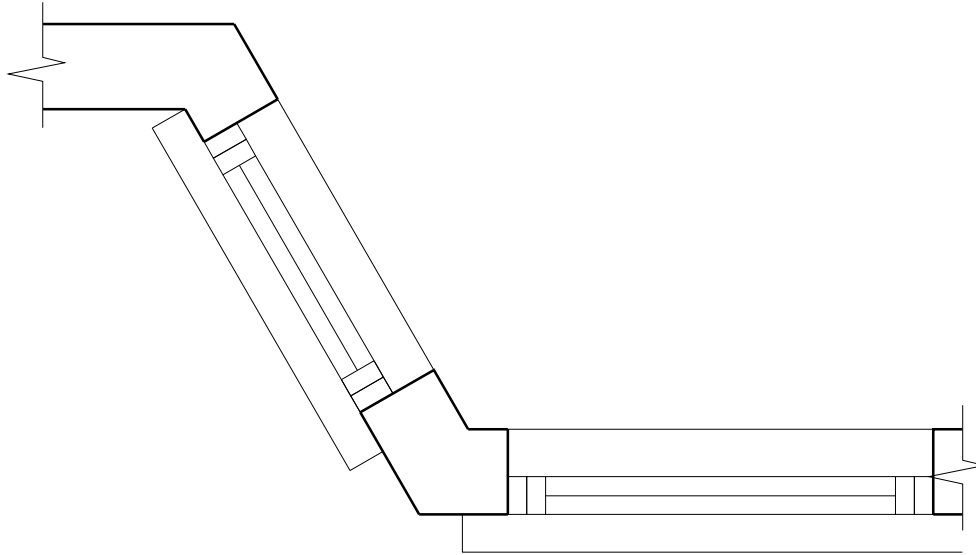

PROPOSED

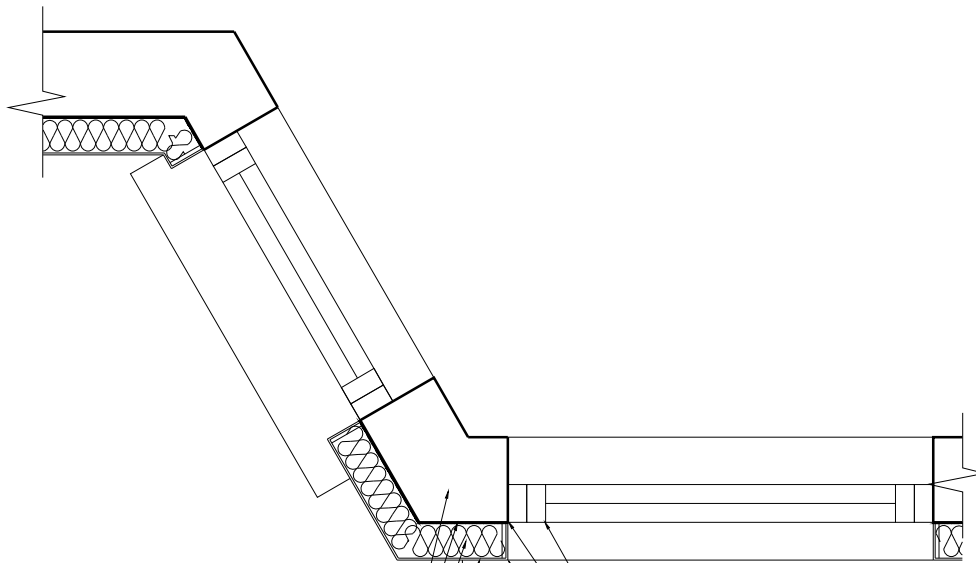

- EXISTING BRICKWORK
- WALL-REFORM PRIMER
- INSULATION
- BRICK SLIPS TO MATCH EXISTING BRICKWORK
- EXISTING WINDOW
- SEALANT
- ROCKCLAD FACIA & SOFFIT BOARD

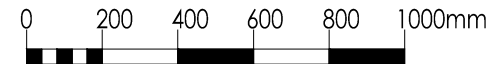

Amendments



DO NOT SCALE FOR CONSTRUCTION



BUILDING SURVEYING
ARCHITECTURE
PROJECT MANAGEMENT
QUANTITY SURVEYING

HOLMBURY HOUSE
DORKING BUSINESS PARK
STATION ROAD, DORKING
SURREY RH4 1HJ
T 01306 887070
F 01306 876716
admin@bpg.co.uk
www.bpg.co.uk

PROJECT

ORIGIN HOUSING -
OVERCLADDING

CLIENT

ORIGIN HOUSING

DATE APR 2011

DRAWN SD CHECKED RM

SCALE 1:20@A4 FOR 1:10@A2 PLANNING

TITLE
DETAIL 3

DRAWING NO. 3346/DE03 REV *

EXISTING

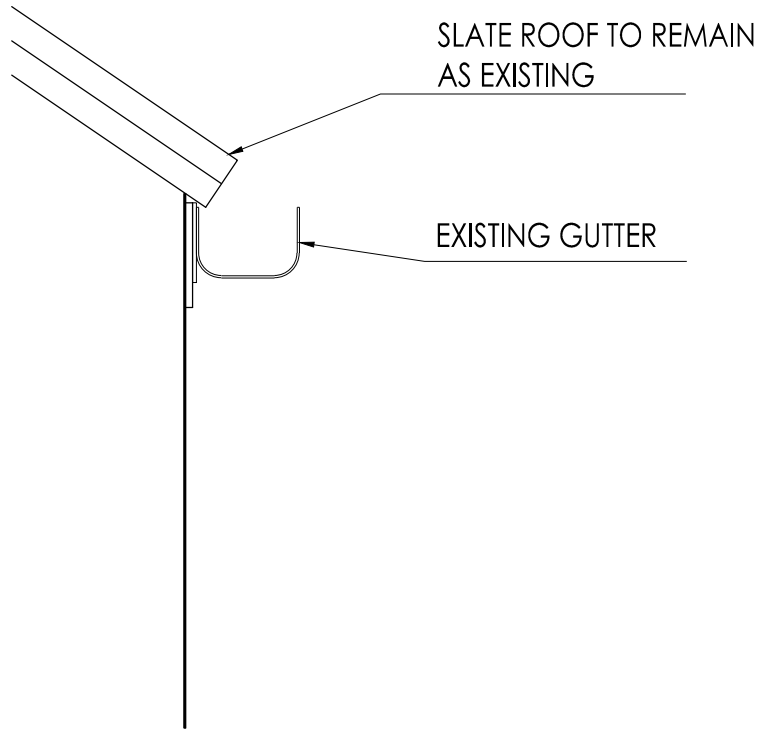

PROPOSED

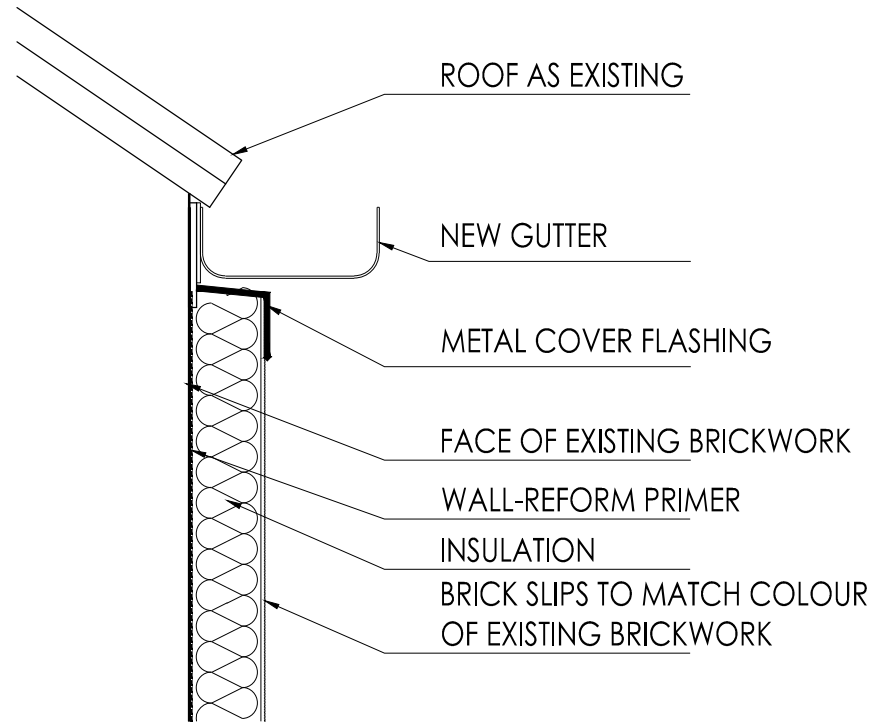

Amendments



DO NOT SCALE FOR CONSTRUCTION



BUILDING SURVEYING
ARCHITECTURE
PROJECT MANAGEMENT
QUANTITY SURVEYING

HOLMBURY HOUSE
DORKING BUSINESS PARK
STATION ROAD, DORKING
SURREY RH4 1HJ
T 01306 887070
F 01306 876716
admin@bpg.co.uk
www.bpg.co.uk

PROJECT

ORIGIN HOUSING -
OVERCLADDING

CLIENT

ORIGIN HOUSING

DATE APR 2012

DRAWN SD CHECKED RM

SCALE 1:10@A4 FOR PLANNING
1:5@A2

TITLE
DETAIL 4

DRAWING NO. 3346/DE04 REV *

EXISTING

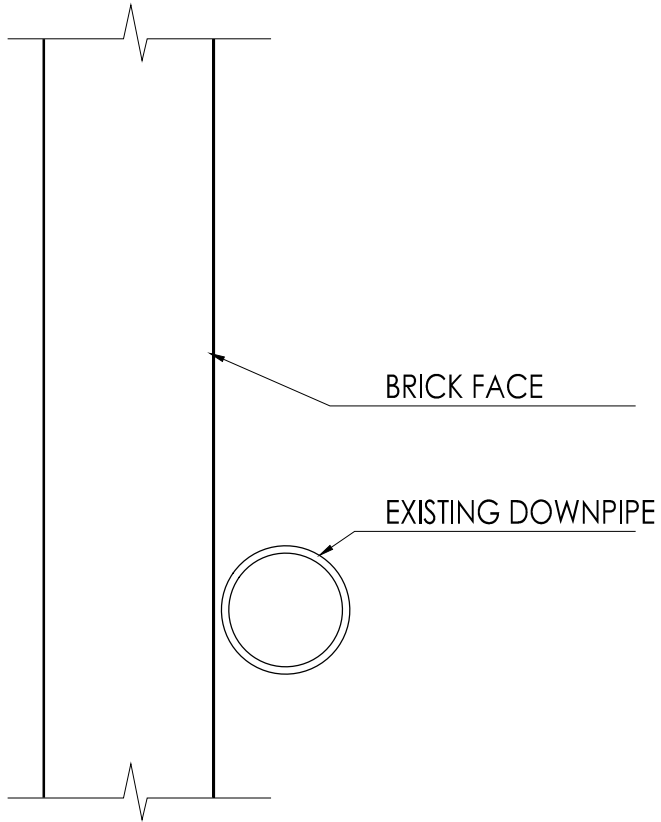

BRICK FACE

EXISTING DOWNPIPE

PROPOSED

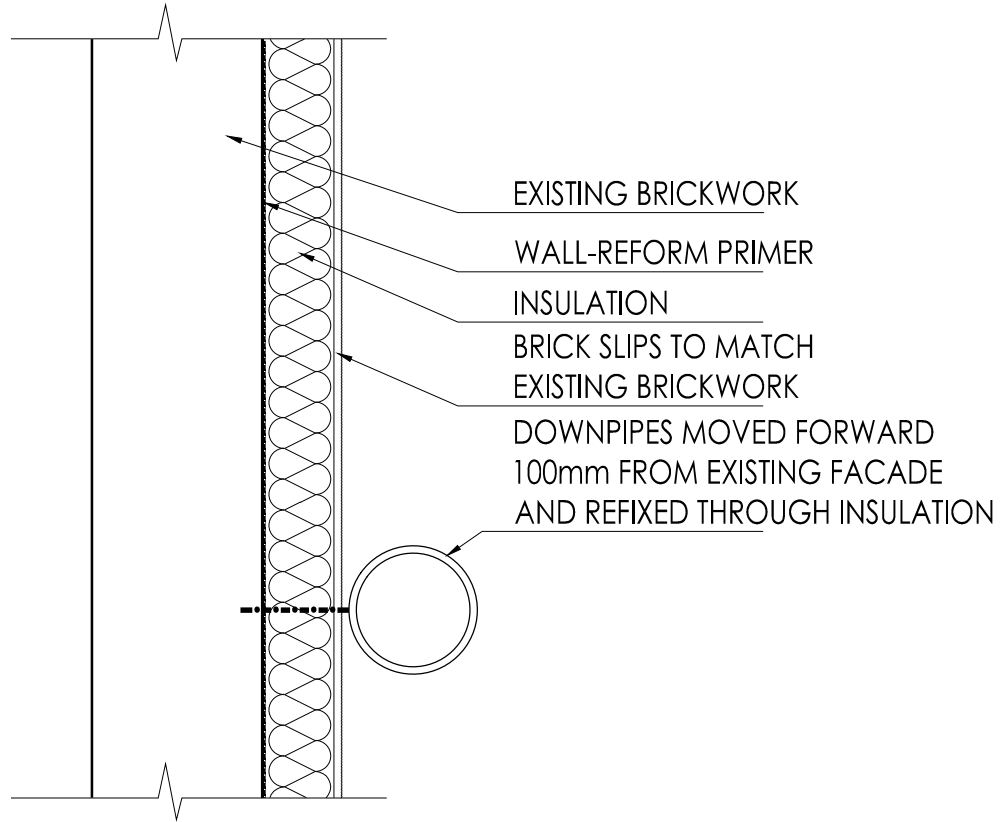

EXISTING BRICKWORK

WALL-REFORM PRIMER

INSULATION

BRICK SLIPS TO MATCH
EXISTING BRICKWORK

DOWNPIPES MOVED FORWARD
100mm FROM EXISTING FACADE
AND REFIXED THROUGH INSULATION

Amendments



DO NOT SCALE FOR CONSTRUCTION

**brodie
plani
goddard**

BUILDING SURVEYING
ARCHITECTURE
PROJECT MANAGEMENT
QUANTITY SURVEYING

HOLMBURY HOUSE
DORKING BUSINESS PARK
STATION ROAD, DORKING
SURREY RH4 1JU

T 01306 887070
F 01306 876716
admin@bpg.co.uk
www.bpg.co.uk

PROJECT
**ORIGIN HOUSING -
OVERCLADDING**

CLIENT
ORIGIN HOUSING

DATE
APR 2012

DRAWN SD CHECKED RM

SCALE 1:10@A4 FOR 1:5@A2 PLANNING

TITLE
DETAIL 5

DRAWING NO. **3346/DE05** REV *



EXISTING

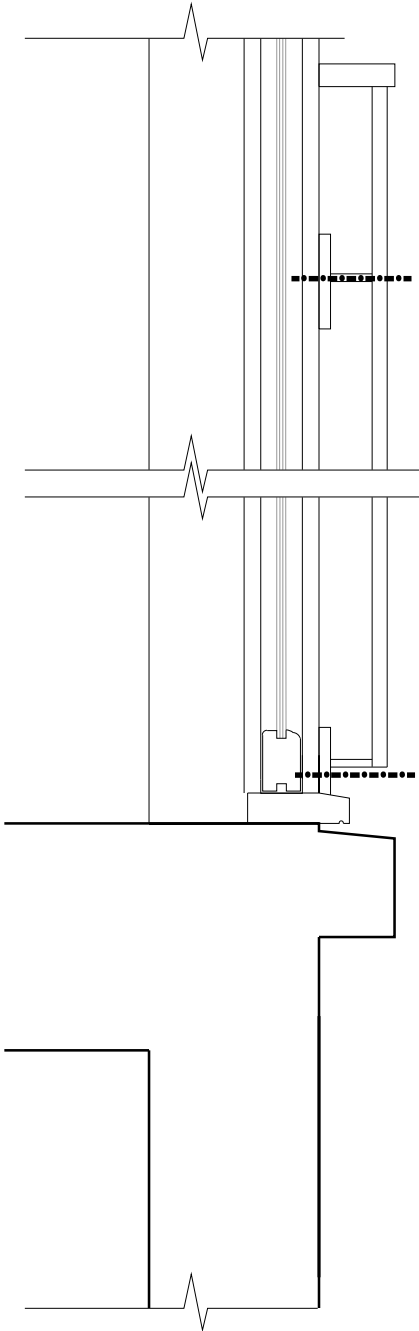

PROPOSED

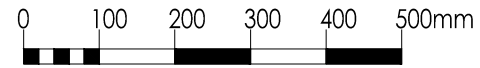
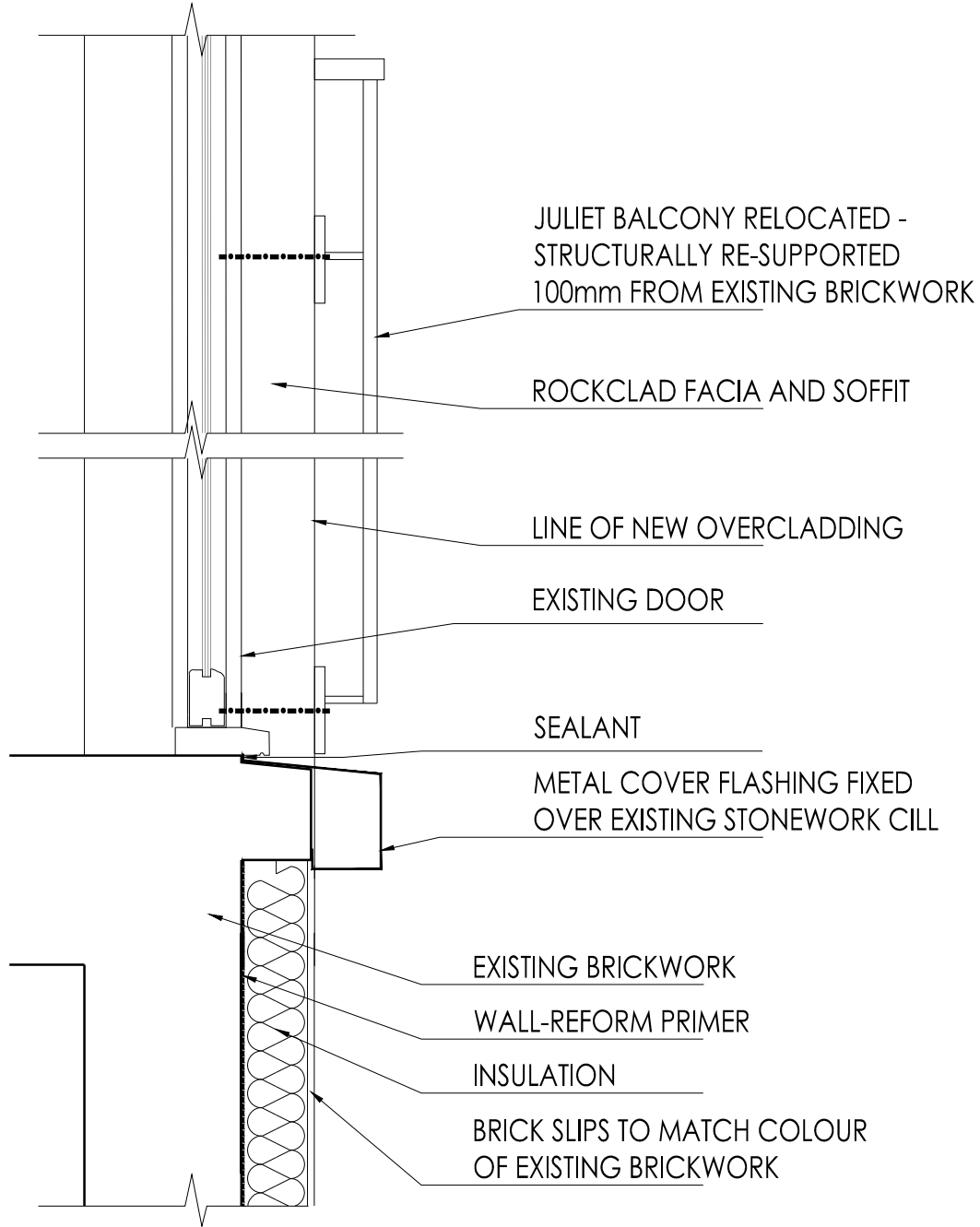

JULIET BALCONY RELOCATED -
STRUCTURALLY RE-SUPPORTED
100mm FROM EXISTING BRICKWORK

ROCKCLAD FACIA AND SOFFIT

LINE OF NEW OVERCLADDING

EXISTING DOOR

SEALANT

METAL COVER FLASHING FIXED
OVER EXISTING STONEWORK CILL

EXISTING BRICKWORK

WALL-REFORM PRIMER

INSULATION

BRICK SLIPS TO MATCH COLOUR
OF EXISTING BRICKWORK

Amendments



DO NOT SCALE FOR CONSTRUCTION

brodie plant goodard
BUILDING SURVEYING
ARCHITECTURE
PROJECT MANAGEMENT
QUANTITY SURVEYING

HOLMBURY HOUSE
DORKING BUSINESS PARK
STATION ROAD, DORKING
SURREY, RH4 1HJ
T: 01306 887070
F: 01306 876716
admin@bpg.co.uk
www.bpg.co.uk

PROJECT
ORIGIN HOUSING -
OVERCLADDING

CLIENT
ORIGIN HOUSING

DATE
APR 2012

DRAWN SD CHECKED RM

SCALE 1:10@A4 FOR PLANNING
1:5@A2

TITLE
DETAIL 6

DRAWING NO. 3346/DE06 REV *

EXISTING

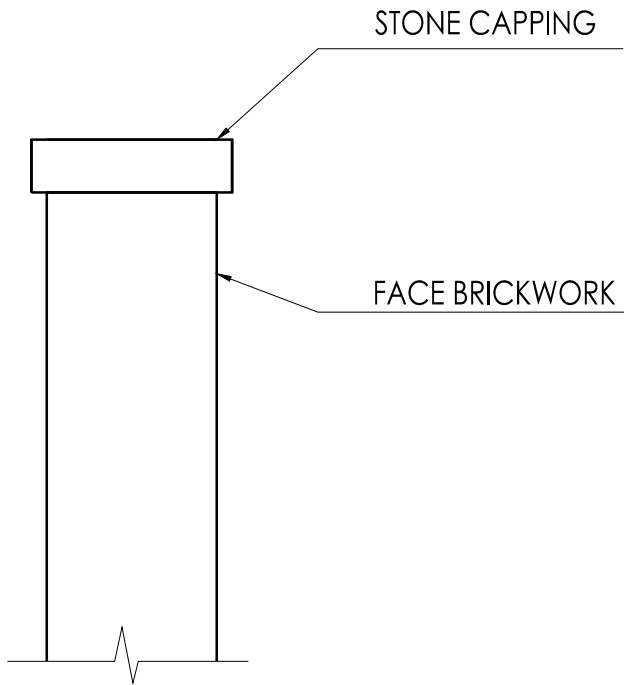

PROPOSED

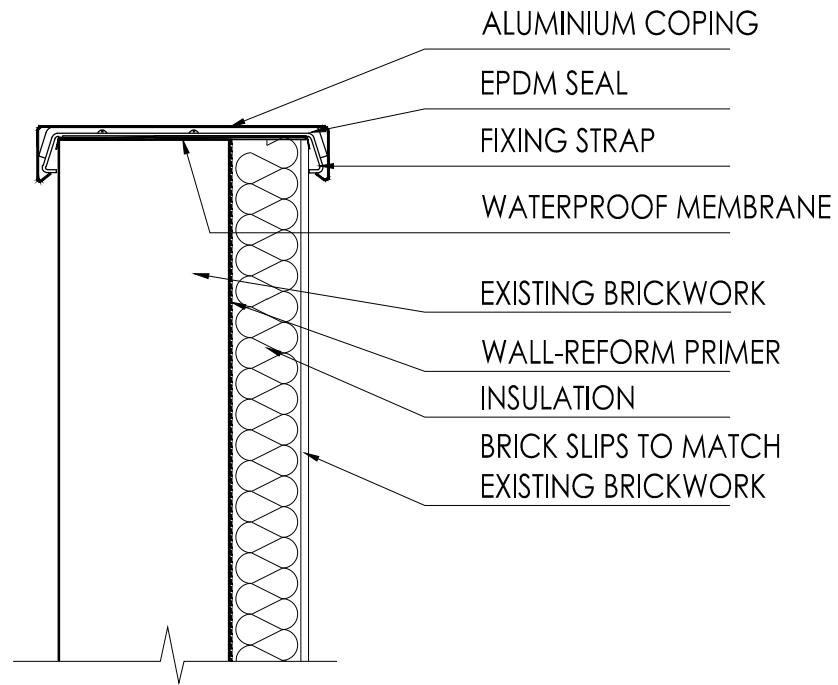

Amendments



DO NOT SCALE FOR CONSTRUCTION



BUILDING SURVEYING
ARCHITECTURE
PROJECT MANAGEMENT
QUANTITY SURVEYING

HOLMBURY HOUSE
DORKING BUSINESS PARK
STATION ROAD, DORKING
SURREY RH4 1HJ
T 01306 887070
F 01306 876716
admin@bpg.co.uk
www.bpg.co.uk

PROJECT

ORIGIN HOUSING -
OVERCLADDING

CLIENT

ORIGIN HOUSING

DATE

APR 2012

DRAWN

SD

CHECKED

RM

SCALE

1:10@A4
1:5@A2

FOR

PLANNING

TITLE

DETAIL 07

DRAWING NO.

3346/DE07

REV

*

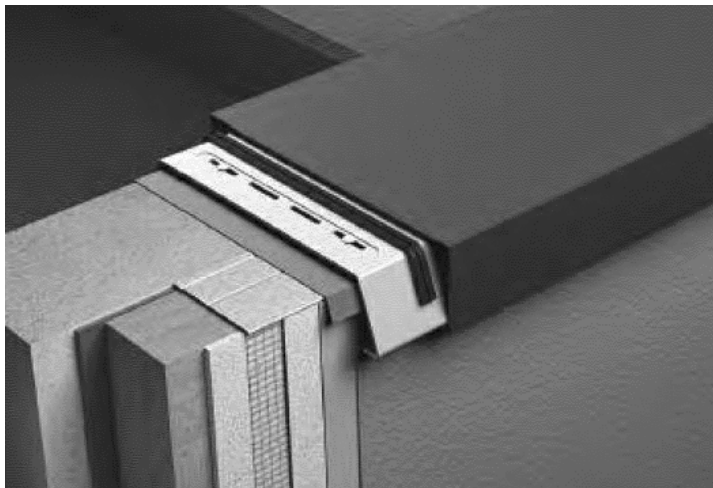

ALUMASC COPING

