

Model:

DCU3-3L

Class:

DCU Hermetic

Technical data

Characteristics	M.U.	Value
Working temperature	°C	-15 ÷ -40
Starting mode		Direct
Voltage	Volt-Ph-Hz	400/3~/50
Rated input	kW*	2
Rated input	Amp	4.4
Peak current	Amp	27
Max current	Amp	9.1
Refrigerant		R404A
Condensing unit mass	Kg	69

Compressor

Type		Hermetic
Nominal power	kW	1.5

Condenser

Air flow	m³/h	1400
----------	------	------

Connections

Suction	Ø mm	22
Liquid	Ø mm	10



Power data

Tev °C	Ta °C	P watt	P Kcal/h
	20	4203	3615
	25	3812	3278
-15	30	3421	2942
	35	3029	2605
	40	2638	2269
	45	2247	1932
	20	3617	3111
	25	3278	2819
-20	30	2940	2528
	35	2601	2237
	40	2263	1946
	45	1925	1656
	20	2999	2579
	25	2715	2335
-25	30	2430	2090
	35	2146	1846
	40	1861	1600
	45	1577	1356
	20	2396	2061
	25	2163	1860
-30	30	1930	1660
	35	1697	1459
	40	1464	1259
	45	1231	1059
	20	1852	1593
	25	1664	1431
-35	30	1478	1271
	35	1291	1110
	40	1104	949
	45	917	789
	20	1411	1213
	25	1261	1084
-40	30	1111	955
	35	962	827
	40	812	698
	45	662	569

* When normally running
 Tev:Evaporating temp. - Ta:External temp.
 P: Refrigerant capacity

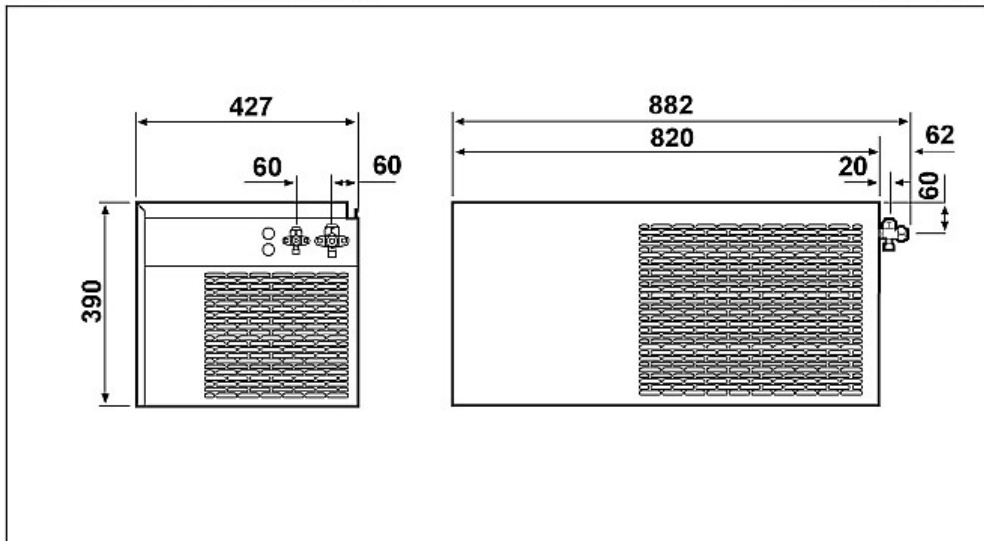

Schema di montaggio - Mounting scheme - Schema de montage
 Montageschema - Esquema de montaje

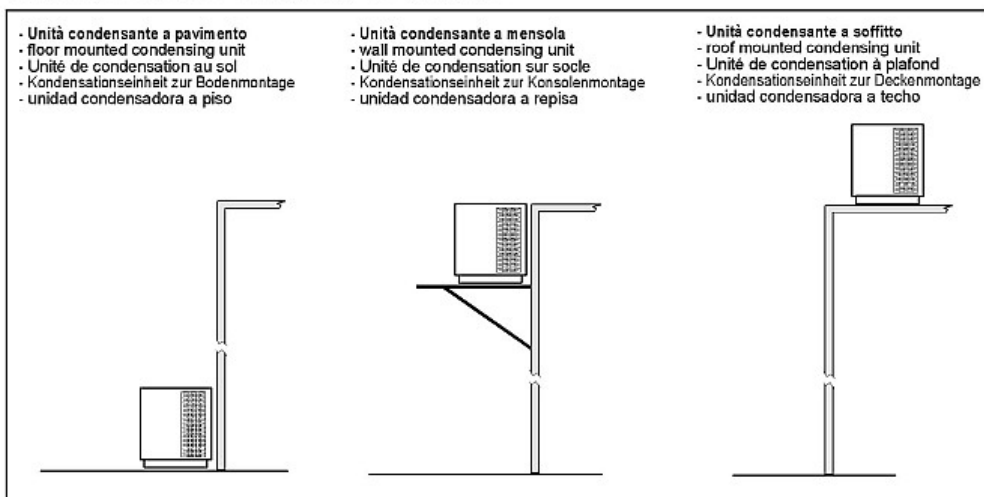

- * Raccomandazioni in sede di installazione e per il controllo fornite sul manuale di installazione
- * To be advised at time of order for factory installation and operating instructions
- * Recommendations au moments d'installations et pour le contrôle fournis sur le manuel d'installation
- * Empfehlungen für die Installationsphase und zur Kontrolle, die im Handbuch zur Installation enthalten sind
- * Por cuanto respecta a recomendaciones de instalación y control ver manual de instalación

Massa e misure imballi - Packing mass and dimensions - Masse et dimensions emballages
 Verpackungsmasse und-abmessungen - Masa y medidas del embalaje

