

SECTION THROUGH

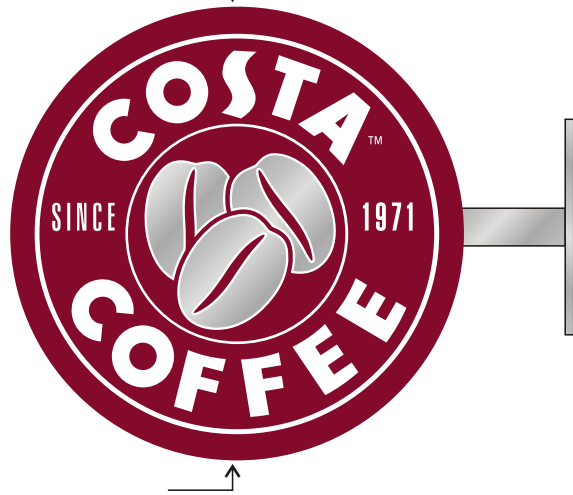

SECTION

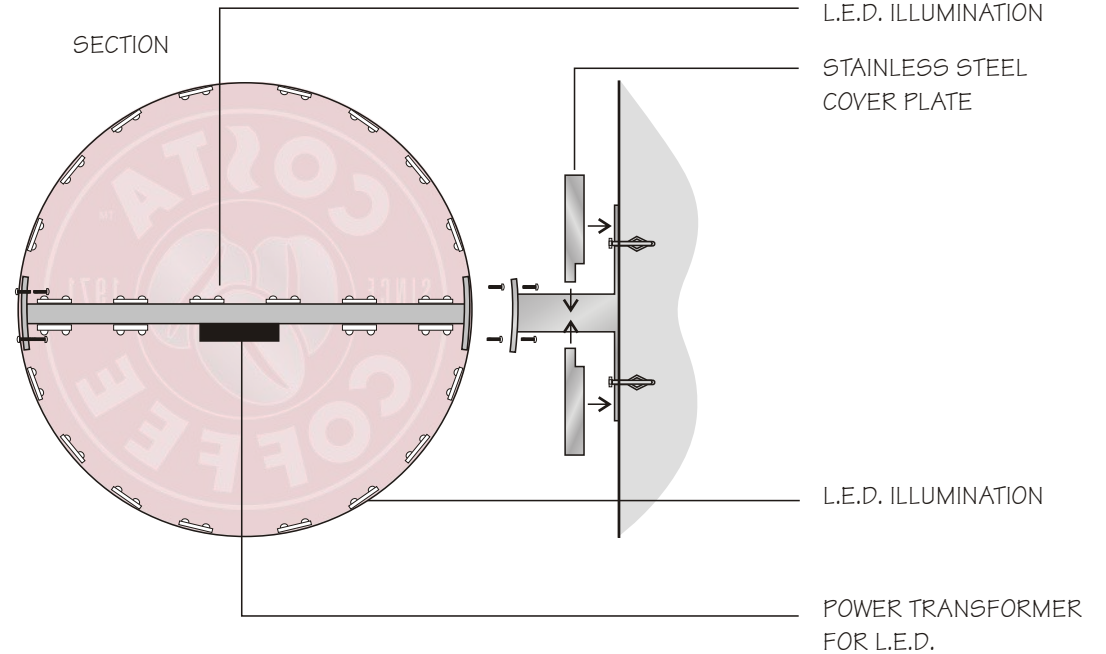

### PROJECTING SIGN

DOUBLE-SIDED 600mm DIAMETER PROJECTING SIGN.  
 SCREEN PRINTED POLYCARBONATE PANELS  
 FIXED TO A RIM & RETURN BUILT-UP, MOUNTED ONTO INTERNAL SUB-FRAME  
 WITH DE-SCALED STAINLESS STEEL BEADED EDGE.  
 LASER CUT STAINLESS STEEL BEANS BONDED TO FACE.  
 FIXED USING INTEGRAL GALVANISED STEEL FRAME FINISHED WHITE  
 WITH MATCHING STAINLESS STEEL BUILT-UP COVER PLATE FOR BRACKET.  
 INTERNAL CASING SPRAYED GLOSS WHITE.  
 INTERNAL WHITE L.E.D. ILLUMINATION.

Scale 1 : 10



**Tel: 0151-298 1567**  
**info@benSON-signs.co.uk**  
**www.benSON-signs.co.uk**



96 - 98 Great Howard Street, Liverpool, L3 7AX