

01 SECTION A - COFFEE  
1:20@ A3

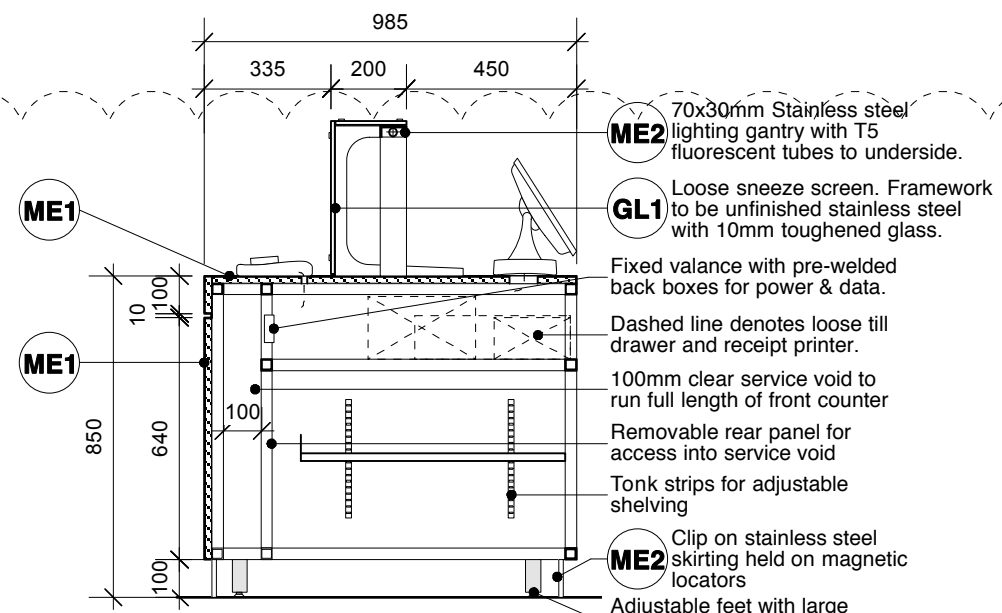

02 SECTION B - TILL  
1:20@ A3

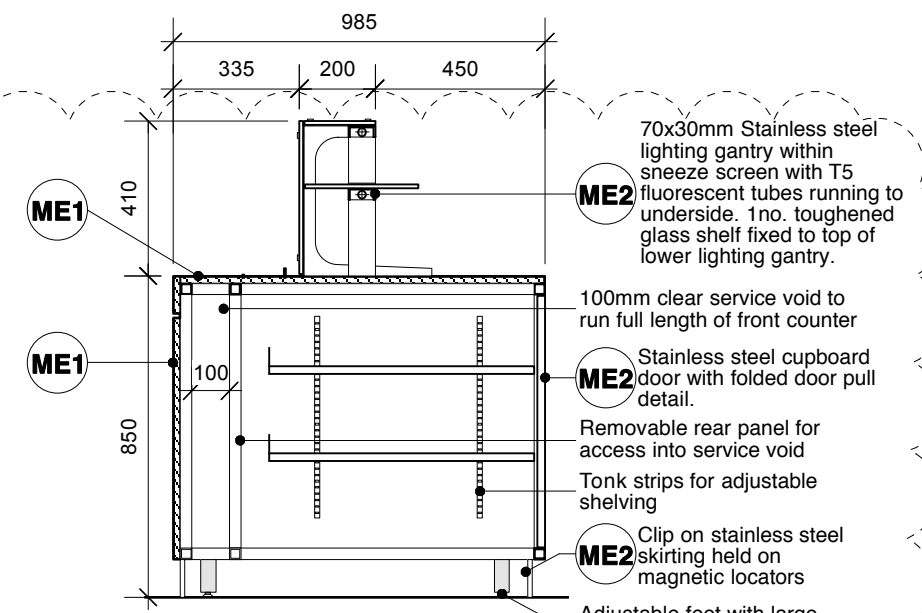

03 SECTION B - AMBIENT  
1:20@ A3

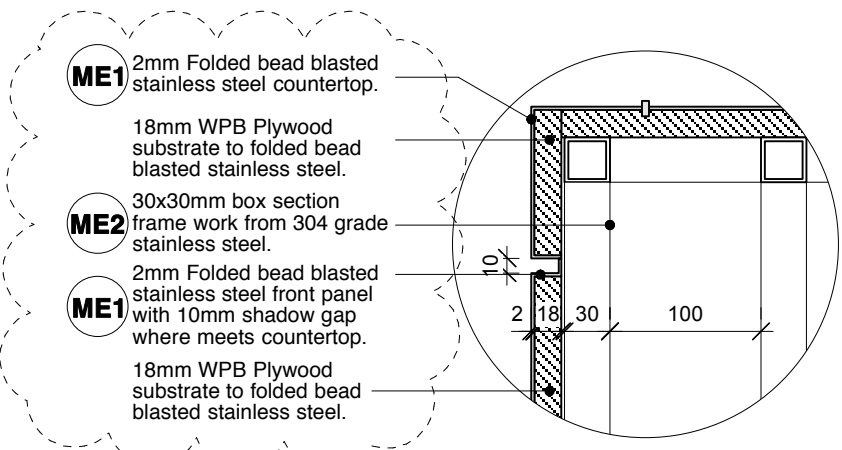

04 DETAIL A  
1:5@ A3

A 23.07.13 Finish references added.

DESCRIPTION  
**FRONT COUNTER SECTIONS**

CLIENT  
**BENUGO**  
PROJECT  
**BRITISH MUSEUM**  
ADDRESS  
**Great Russell Street, WC1B 3DG**

JOB No. DWG No. REV.  
**895.P03.1 A**

DATE STATUS  
**JUN 2013 INFORMATION**

DWN BY  
**SW**  
SCALE  
**1:20 & 1:5 @A3**

THIS DRAWING IS FOR DESIGN INTENT PURPOSES ONLY. DO NOT SCALE THIS DRAWING.  
 • Contractors should provide their own setting out drawings for comment by PATH DESIGN.  
 • This drawing is the property of PATH DESIGN and copyright is reserved by them.  
 • All structural works are to be detailed / confirmed and approved by structural engineer.  
 • All dimensions to be verified on site prior to work commencing.  
 • This drawing is issued on condition that it is not copied or disclosed to any other authorised person without the prior consent of PATH DESIGN.

Path Design  
Unit 5, 7 Wenlock Road London N1 7SL  
T +44 (0)20 7253 9005 F +44 (0)20 7253 9004  
www.pathdesign.co.uk info@pathdesign.co.uk

