

18-02 FRONT ELEVATION

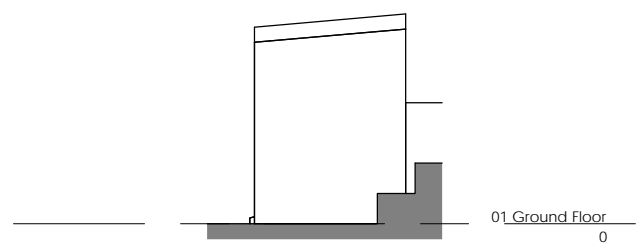

18-04 SIDE ELEVATION (17 PARKHILL RD)

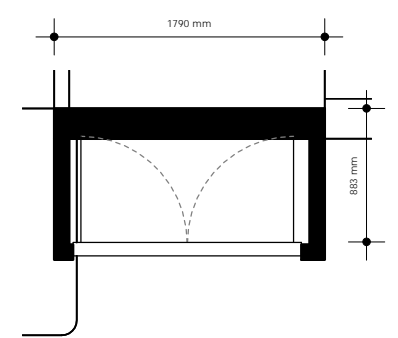

18-01 PLAN

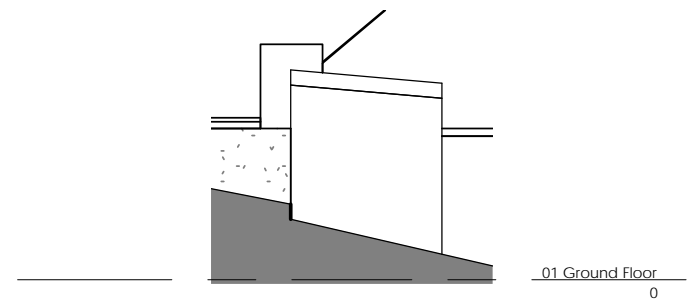

18-05 SIDE ELEVATION (19 PARKHILL RD)

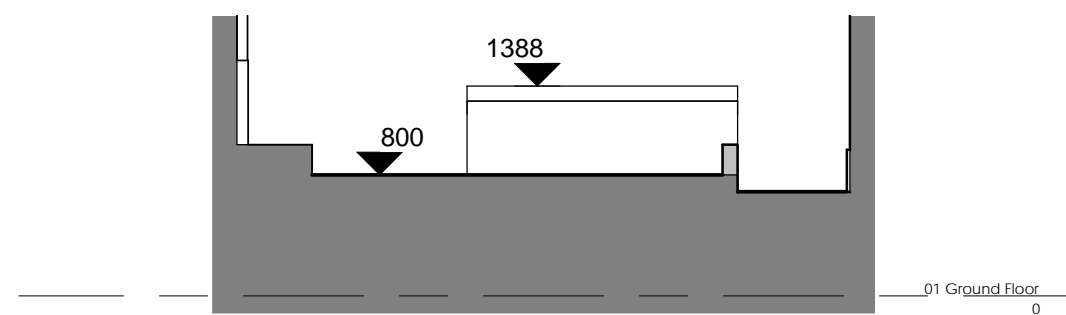

18-03 STREET ELEVATION

## 18-00 Proposed Bin Store

REV	DATE	NOTE

THE CONTRACTOR SHOULD CHECK ALL DIMENSIONS ON SITE.  
 NO DIMENSIONS TO BE SCALED FROM THIS DRAWING (EXCEPT BY PLANNING AUTHORITIES FOR PLANNING PURPOSES).  
 NO PART OF THIS DRAWING IS TO BE COPIED OR REPRODUCED WITHOUT THE PRIOR CONSENT OF THE ARCHITECT.  
 IT IS THE CONTRACTORS RESPONSIBILITY TO ENSURE COMPLIANCE WITH THE BUILDING REGULATIONS.  
 ALL RIGHTS DESCRIBED IN CHAPTER IV OF THE COPYRIGHT, DESIGNS AND PATENTS ACT 1988 HAVE GENERALLY BEEN ASSERTED. ©



Project: Coach House, 17 Parkhill, Belsize Park, London, NW3 2YH  
 C180 - 18 Proposed Bin Store (Rev A)  
 Client: Martha Properties Ltd  
 Scale @ A3: 1 : 50 Date: March 2013  
 TENPOINTFIVE architecture 182 WHITTINGTON WAY, PINNER, HA5 5JY T: 020 8429 9206 E: MAIL@TENPOINTFIVE.CO.UK