

# Technical Guide

PVC-U Windows and Doors Systems

ISSUE 8

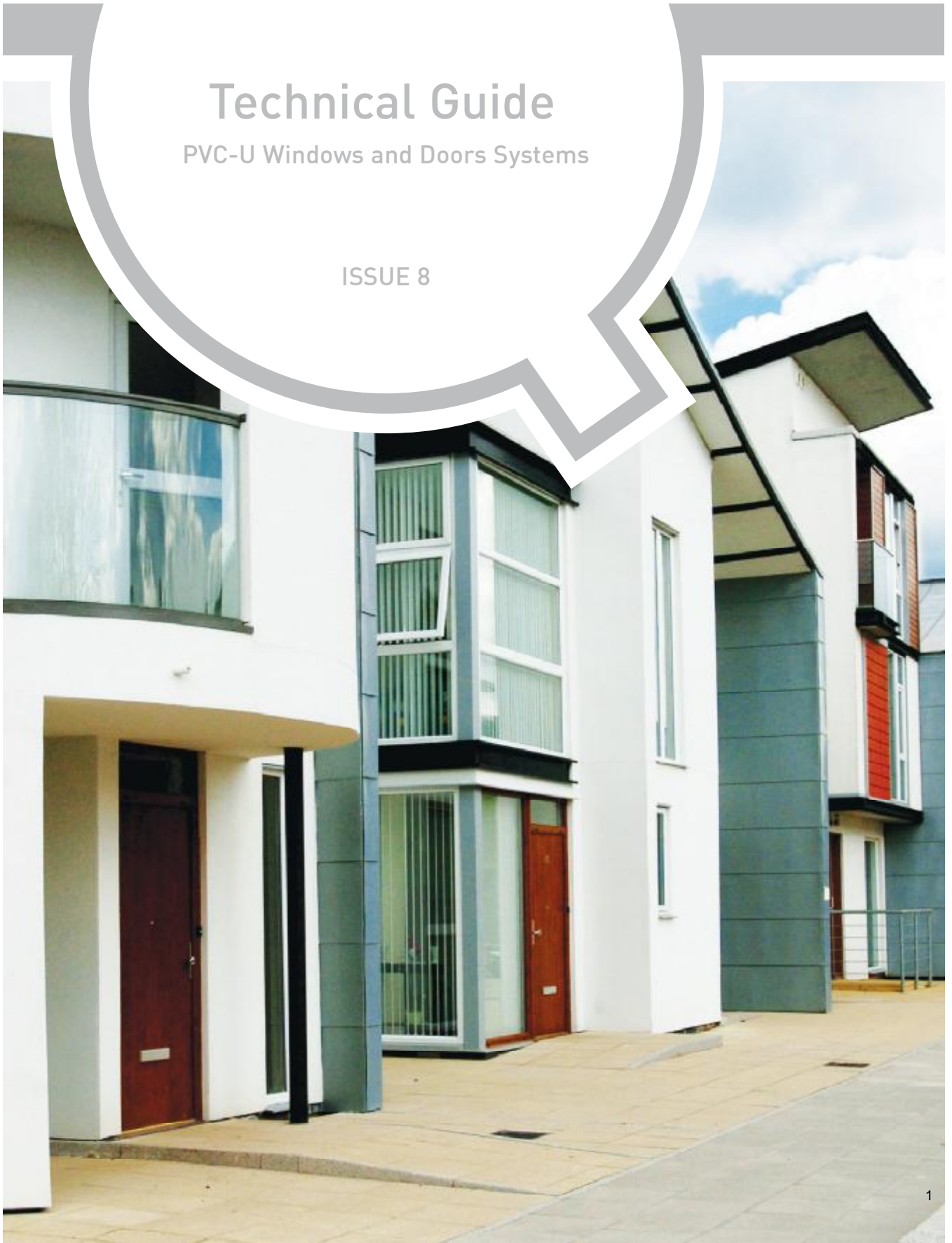

# Contents

## 1. Product

### Window Styles

Casement Window	4
- FC60 (60mm Fully Chamfered)	5-11
- FI70 (70mm Fully Integrated)	12-18
- FB70 (70mm Fully Bevelled)	19-20
- FS70 (70mm Fully Sculptured)	21-22
Tilt-Turn Window	23
- FC60 (60mm Fully Chamfered)	24
- FI70 (70mm Fully Integrated)	25
- FB70 (70mm Fully Bevelled)	26
- FS70 (70mm Fully Sculptured)	27
Horizontal Pivot Window	28
- FC60 (60mm Fully Chamfered)	29
- FI70 (70mm Fully Integrated)	30
- FB70 (70mm Fully Bevelled)	31
- FS70 (70mm Fully Sculptured)	32
Fully Reversible Window	33
- FR70 (70mm Fully Reversible)	34
Miscellaneous Applications	35
- Concrete Cill Infill	36
- Box Sash Adaptor	36

### Door Styles

Residential Door	37
- FC60 (60mm Fully Chamfered)	38-41
- FI70 (70mm Fully Integrated)	42-45
- FB70 (70mm Fully Bevelled)	46-47
- FS70 (70mm Fully Sculptured)	48-49
Doors With Side Screens	50-51
Composite Door	52
- CD60 (60mm Suite)	53
- CD70 (70mm Suite)	54
In-line Sliding Patio Door	55
- PD86 (86mm Patio Door)	56-57

### Curtain Wall

Curtain Wall System	58
- SK200	59-60

### New Build

Window Former & Cavity Closer	61
- Camfast	62-67
- Cavimaster	68-71

## 2. Product Characteristics

### Performance

Weather Performance	73
Test Procedures	74
Wind Loads	75
Wind Pressure, Speed, Load Tables	76
Determining Structural Suitability	77-78
Bay Window Plans	79
Conservatory Roof Plans	79
Load Bearing Capacities	80
Outer Frame Reinforcement and Ixx	81
Mullion/Transom Reinforcement and Ixx	81
Baypoles & Reinforcement Options	82
Coupling Options	82
PVC-U & Fire	83
Summary of PVC Combustion Properties	84
Condensation Cause & Effect	85
Condensation Combatting	86
Condensation	87
Guide to Sound Reduction Windows	88
Window Energy Ratings	89
Approved Tables	90-92

# Contents

## 2. Product Characteristics

### Building Regulations

Document B - Safety & Means of Escape	94
Document E - Sound Performance	95
Document F - Ventilation	96-97
Document K - Protection from Collision	98
Document K - Protection against Impact	99
Document L - Thermal Performance	100
Document M - Wheel Chair Access	101
Document N - Safe Opening & Closing	102
Document N - Safe Access for Cleaning	103
Document N - Use of Safety Glass	104

### Glass

Maximum Glass Sizes	106
Safety Glass	107
Safe Breakage	107
Impact Performance	108
Breakage Characteristics	108
Manifestation of Glazing	109
Glass Packing	110

### Maximum Size Limits

Window Sash Sizes	112
Outer Frame Sizes	113
WINFIT <sup>2</sup> Sub Frame Sizes	113
Door Leaf Sizes	114
Slim French Door Leaf Sizes	114
Patio Door Sizes	115
Multi-lights & Reinforcement	116
60mm Multi-light Open-out & TBT	117
70mm Multi-light Open-out & TBT	118
Sashes - Open-out Windows	119
Sashes - Tilt-Turn Windows	119

### Product Care

General Maintenance - Open Out Window	121
General Maintenance - Tilt-Turn Window	122
General Maintenance - Top Swing Window	123
General Maintenance - Residential Door	124

## 3. Reference

### Product Charts

FC60 - 60mm Product Chart	126
FI70 - 70mm Product Chart	127
FB70 - 70mm Product Chart	128
FS70 - 70mm Product Chart	129
Ancillary Chart	130
FR70 - 70mm Product Chart	131
CD60 & CD70 Composite Door Chart	132
PD86 In-line Patio Door Chart	133
SK200 - Curtain Wall Chart	134
Winfit <sup>2</sup> - Cavity Closer Chart	135

### General Information

Frame Weight Calculator	137-138
Frame Weight Calculator - Glass	139
Frame Weight Calculator - Fully Reversible	140
Frame Weight Calculator - Patio Door	141
Glossary of Standards	142-143
Building Details	144-151

# 1 Product



## Window Styles

### Casement Window



# Fully Chamfered 60mm Open-out Window Internal Glazing

CATEGORY	DESCRIPTION	STYLE
PRODUCT	ASSEMBLIES	CASEMENT WINDOW

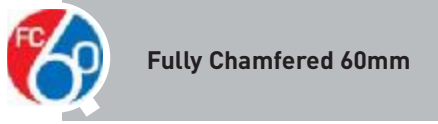

- Open Out Window  
Slim Outer Frame/Std Transom
- Fully Chamfered
- 24mm Double Glazing
- Internally Glazed  
Bevelled Bead
- Bubblex Gasket

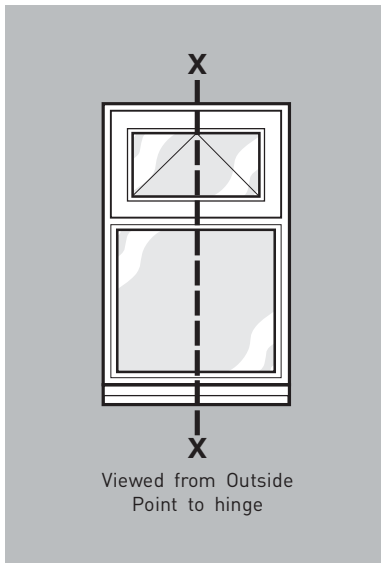

**\*!Note:** All reinforcements shown are for diagramatical purposes only. For applications, please refer to the PROFILE 22 Product Catalogue.

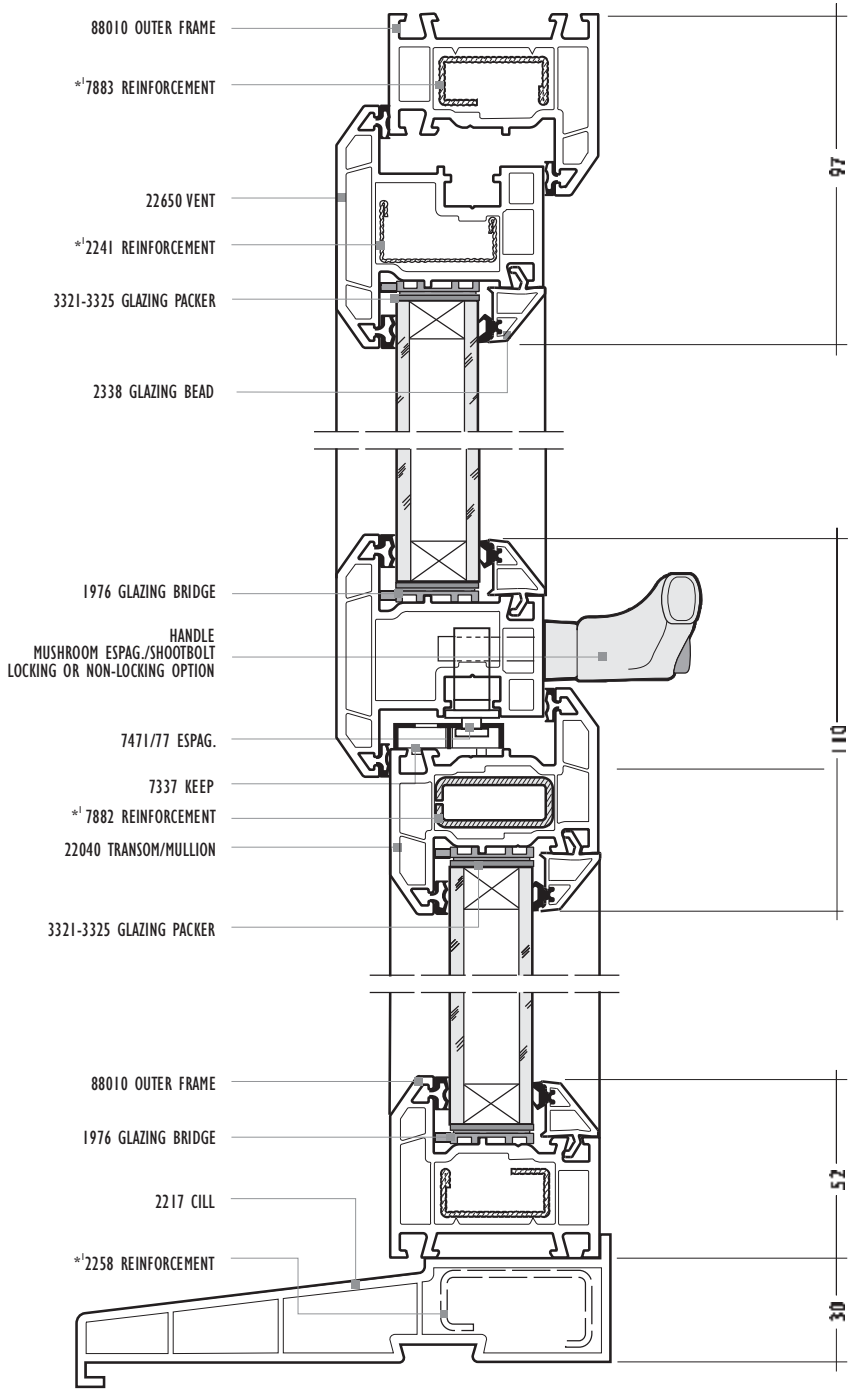

# Fully Chamfered 60mm Open-out Window Internal Glazing

CATEGORY	DESCRIPTION	STYLE
PRODUCT	ASSEMBLIES	CASEMENT WINDOW



## Fully Chamfered 60mm

Open Out Window  
Std Outer Frame/Std Transom

Fully Chamfered

24mm Double Glazing

Internally Glazed  
Scotia Bead

Bubblex Gasket

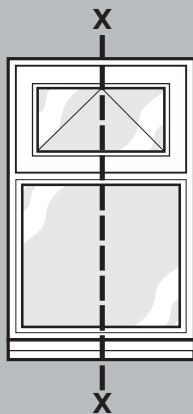

Viewed from Outside  
Point to hinge

**\*1Note:** All reinforcements shown are for diagrammatical purposes only. For applications, please refer to the PROFILE 22 Product Catalogue.

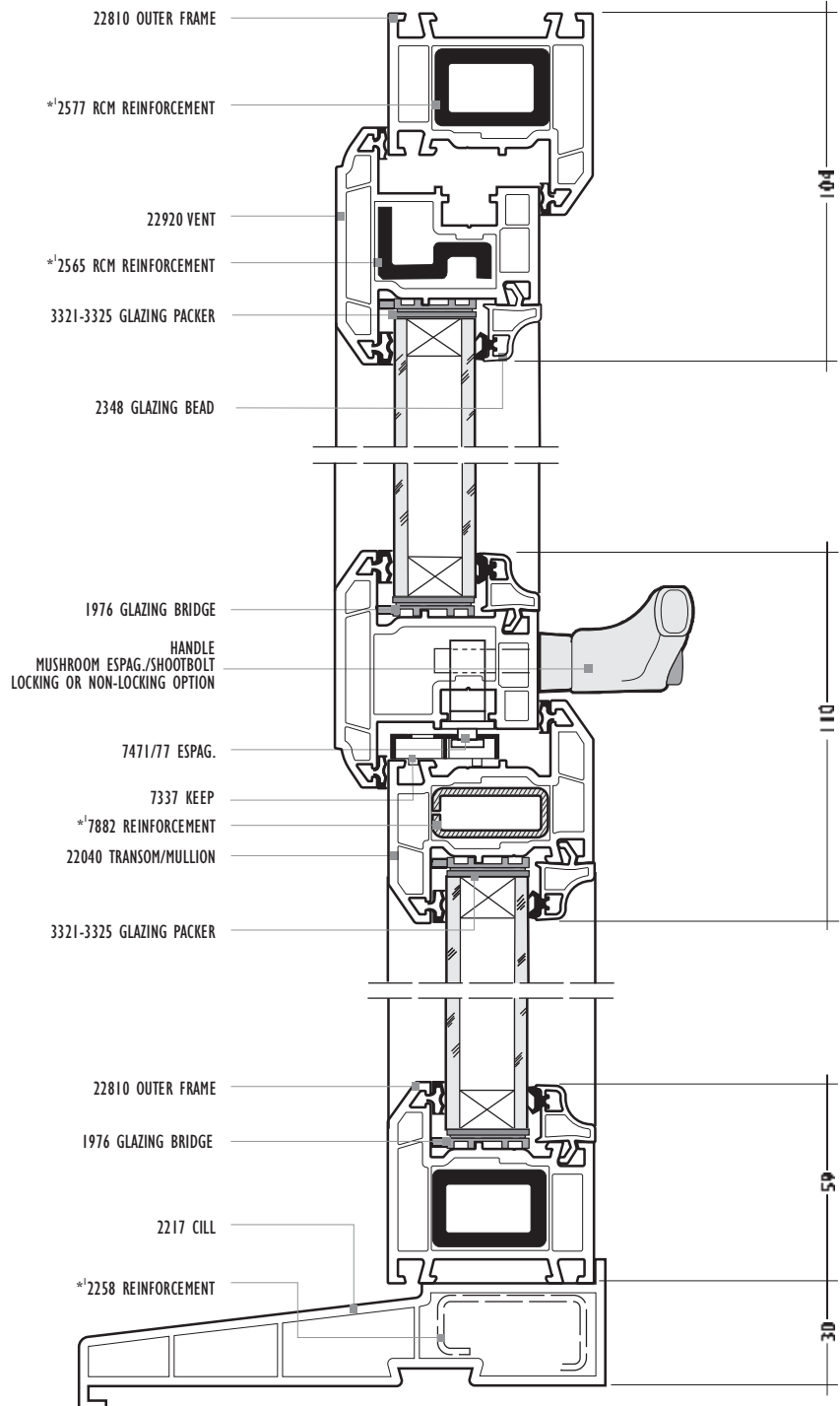

# Fully Chamfered 60mm Open-out Window Internal Glazing

CATEGORY	DESCRIPTION	STYLE
PRODUCT	ASSEMBLIES	CASEMENT WINDOW

## Fully Chamfered 60mm

- Open Out Window  
Large Outer Frame/Std Transom
- Fully Chamfered
- 24mm Double Glazing
- Internally Glazed  
Ovolo Bead
- Bubblex Seals

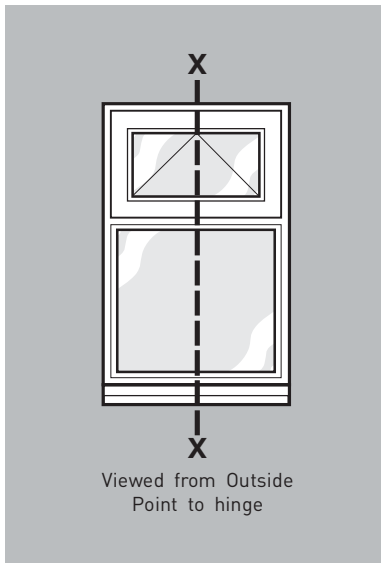

**\*!Note:** All reinforcements shown are for diagrammatical purposes only. For applications, please refer to the PROFILE 22 Product Catalogue.

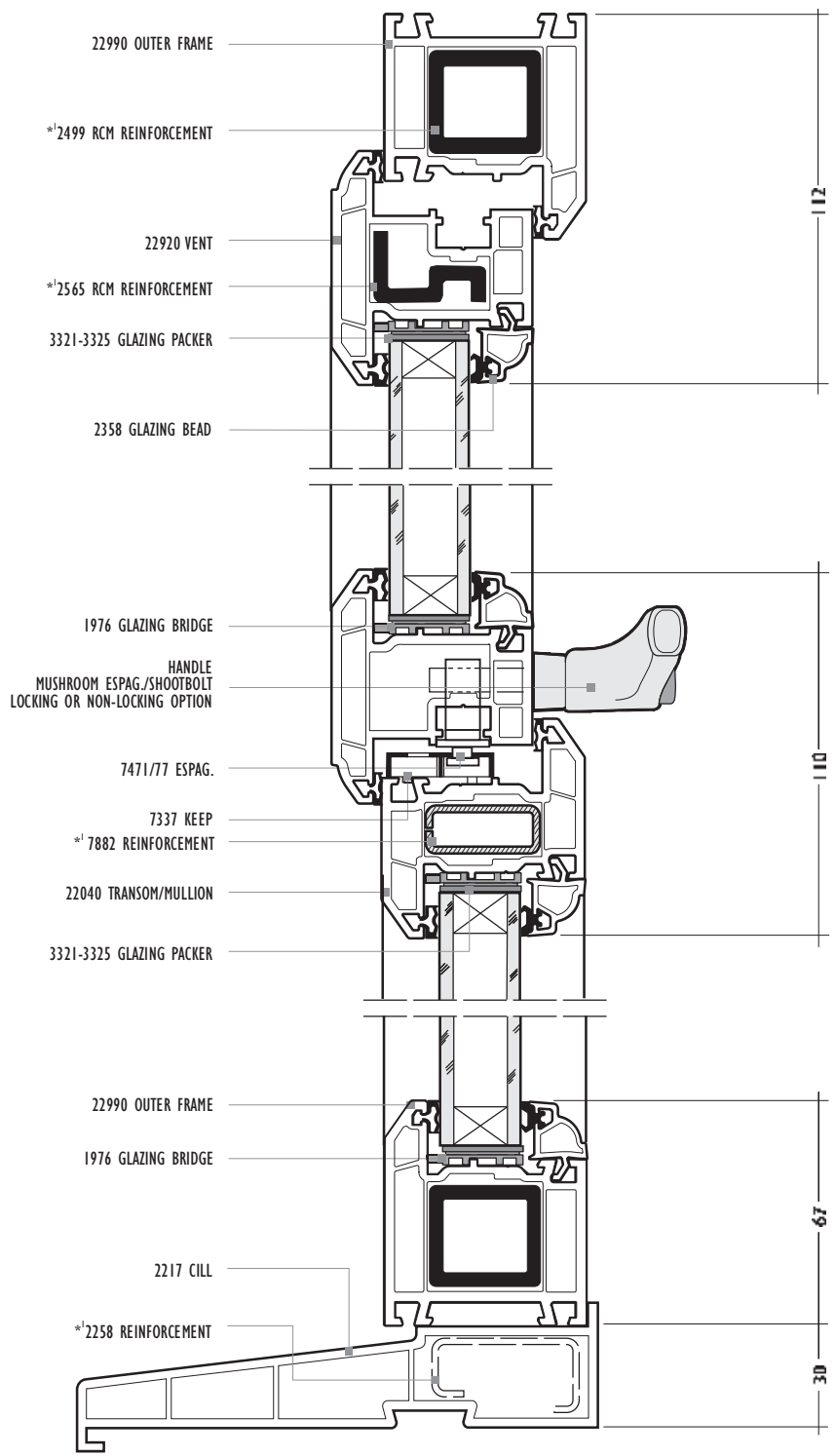

# Fully Chamfered 60mm Open-out Window Internal Glazing

CATEGORY	DESCRIPTION	STYLE
PRODUCT	ASSEMBLIES	CASEMENT WINDOW

## Fully Chamfered 60mm

- Open Out Window  
Large Outer Frame /  
Large Transom
- Fully Chamfered
- 24mm Double Glazing
- Internally Glazed  
Bevelled Bead
- Bubblex Seals

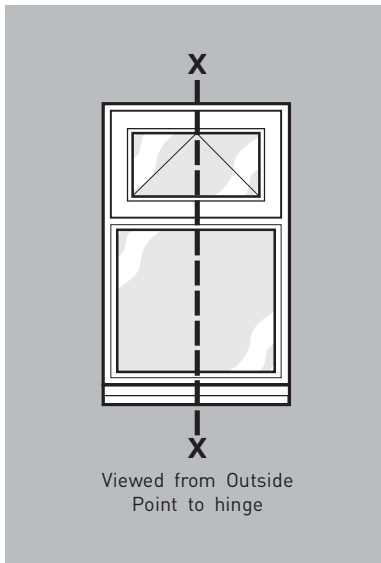

**\*!Note:** All reinforcements shown are for diagrammatical purposes only. For applications, please refer to the PROFILE 22 Product Catalogue.

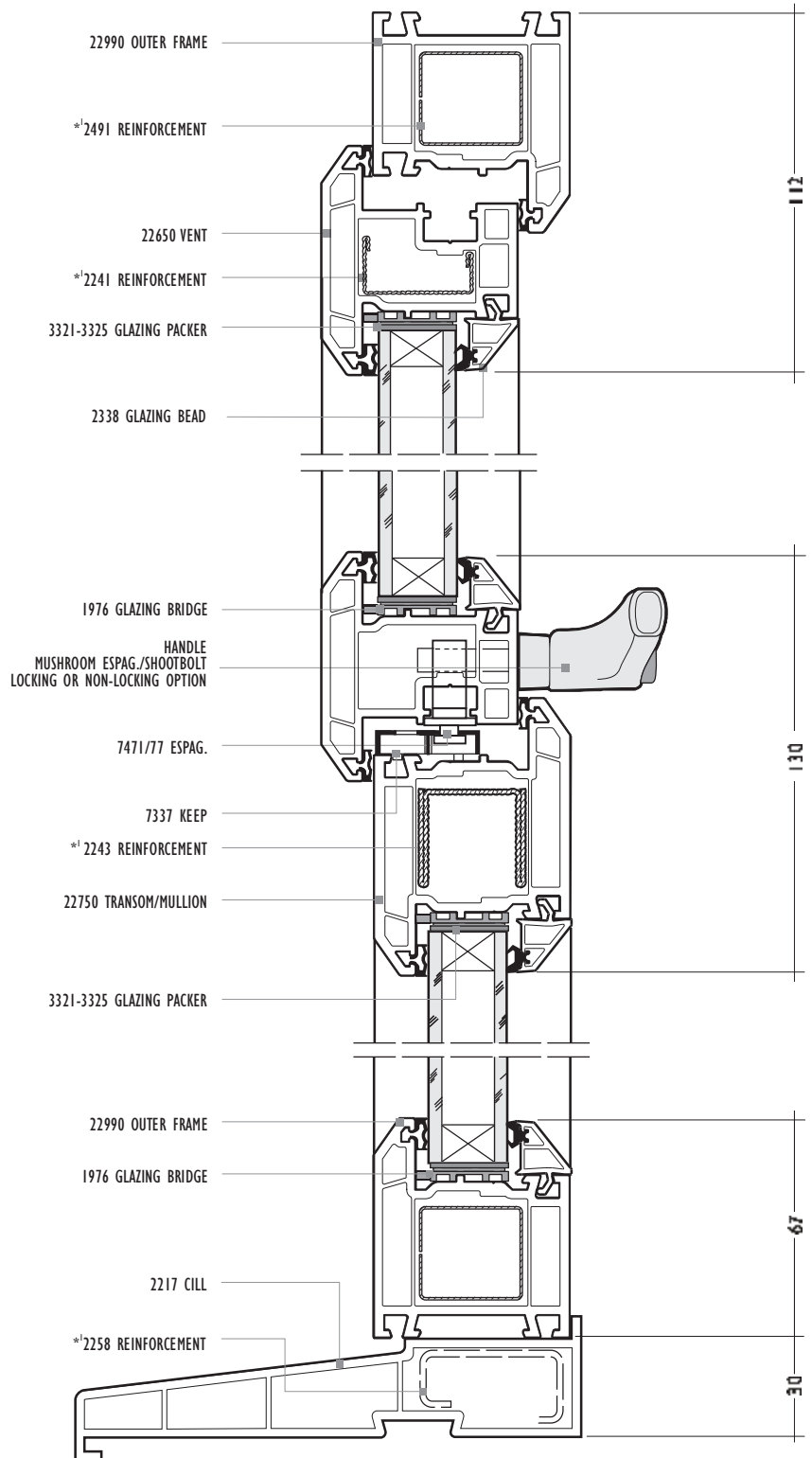



# Fully Chamfered 60mm Open-out Window External Glazing

CATEGORY	DESCRIPTION	STYLE
PRODUCT	ASSEMBLIES	CASEMENT WINDOW



## Fully Chamfered 60mm

-  Open Out Window  
Slim Outer Frame /  
Std Transom
-  Fully Chamfered
-  24mm Double Glazing
-  Externally Glazed  
Ovolo Bead
-  Bubblex Seals

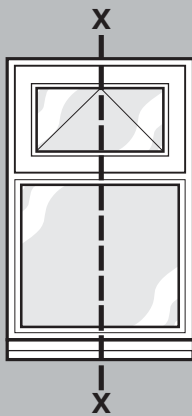

Viewed from Outside  
Point to hinge

**\*Note:** All reinforcements shown are for diagrammatical purposes only. For applications, please refer to the PROFILE 22 Product Catalogue.

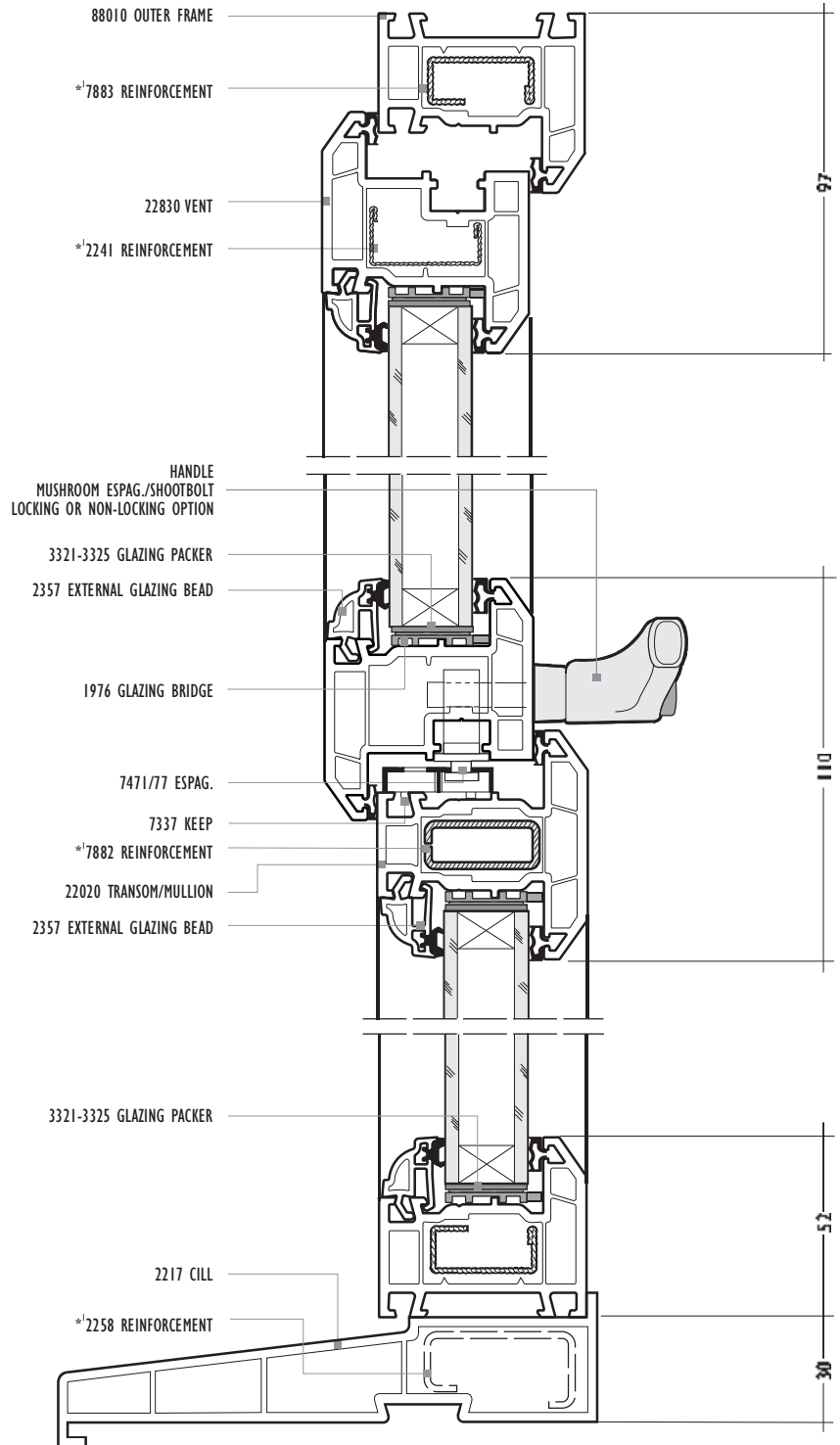

# Fully Chamfered 60mm Open-out Window External Glazing

CATEGORY	DESCRIPTION	STYLE
PRODUCT	ASSEMBLIES	CASEMENT WINDOW



## Fully Chamfered 60mm

-  Open Out Window  
Std Outer Frame/  
Std Transom
-  Fully Chamfered
-  24mm Double Glazing
-  Externally Glazed  
Ovolo Bead
-  Bubblex Seals

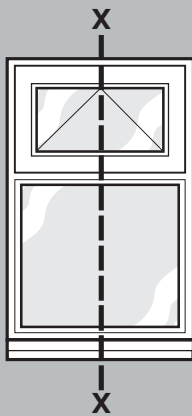

Viewed from Outside  
Point to hinge

**\*!Note:** All reinforcements shown are for diagrammatical purposes only. For applications, please refer to the PROFILE 22 Product Catalogue.

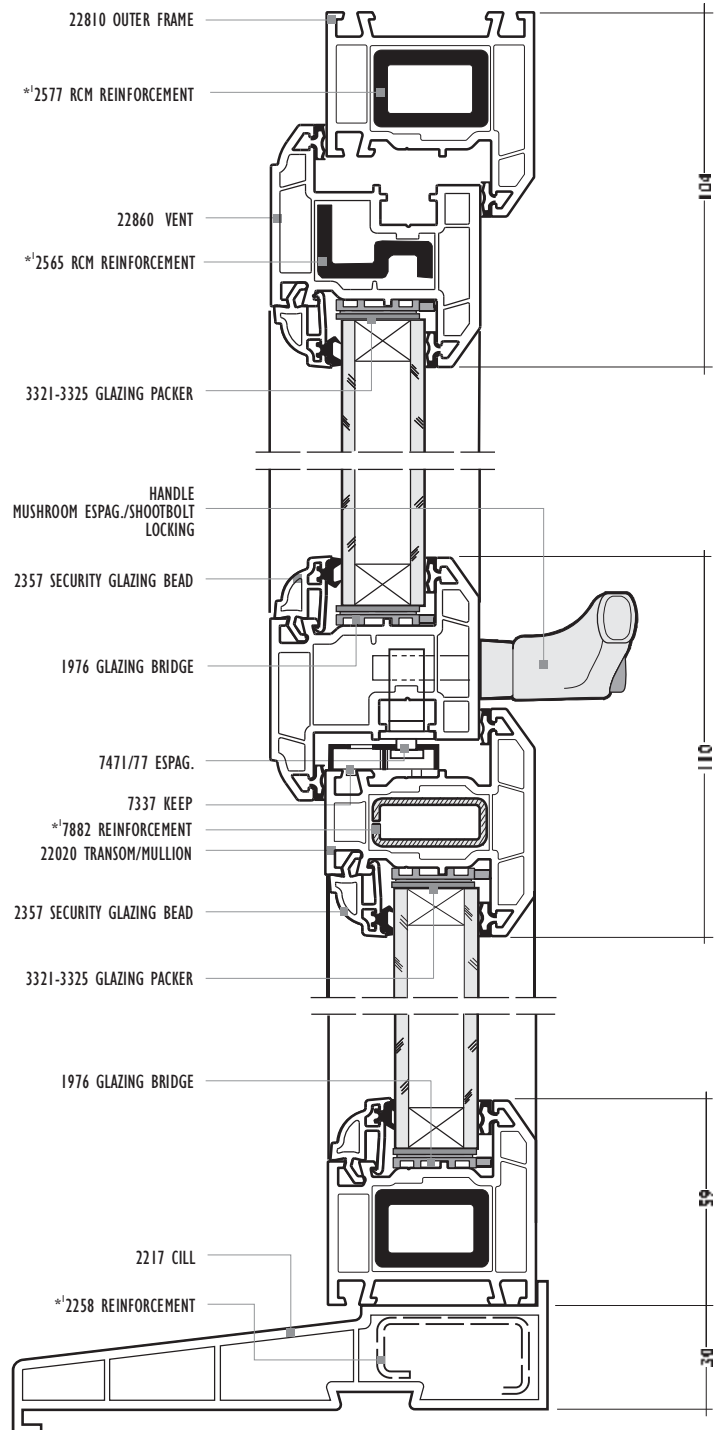

# Fully Chamfered 60mm Open-out Window External Glazing

CATEGORY	DESCRIPTION	STYLE
PRODUCT	ASSEMBLIES	CASEMENT WINDOW



## Fully Chamfered 60mm

-  Open Out Window  
Slim Outer Frame/Std Transom
-  Fully Chamfered
-  24mm Double Glazing
-  Externally Glazed  
Bevelled Bead
-  Security Clips  
Enhanced Security
-  Bubblex Seals

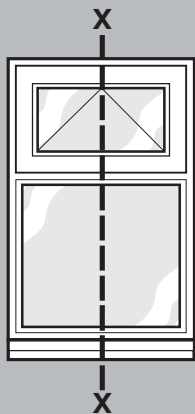

Viewed from Outside  
Point to hinge

**\*1 Note:** All reinforcements shown are for diagrammatical purposes only. For applications, please refer to the PROFILE 22 Product Catalogue.

**\*2 Note:** Detail shows 1822E gasket - on occasions where there are variances due to tolerance build up, alternative gaskets are supplied, i.e. 1808E if glass too tight, 1971 if glass too loose.

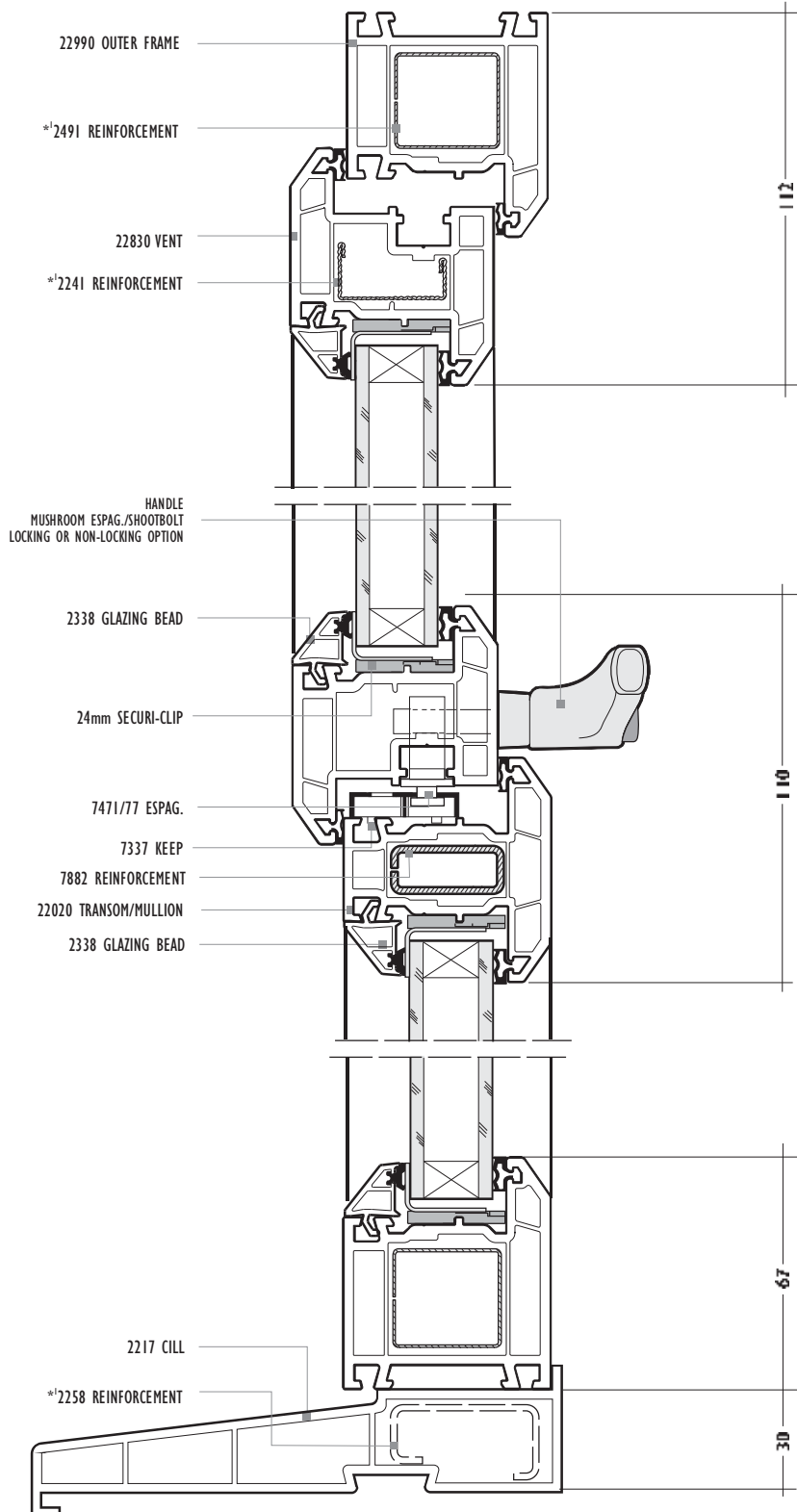

# Fully Integrated 70mm Open-out Window Internal Glazing

CATEGORY	DESCRIPTION	STYLE
PRODUCT	ASSEMBLIES	CASEMENT WINDOW



## Fully Integrated 70mm

Open Out Window  
Std Outer Frame/Std Transom

Fully Integrated

24mm Double Glazing

Internally Glazed  
Scotia Bead

Bubblex Seals

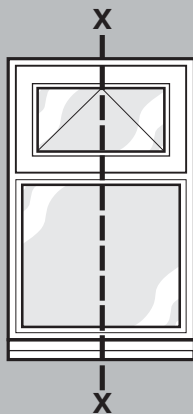

Viewed from Outside  
Point to hinge

**\*!Note:** All reinforcements shown are for diagrammatical purposes only. For applications, please refer to the PROFILE 22 Product Catalogue.

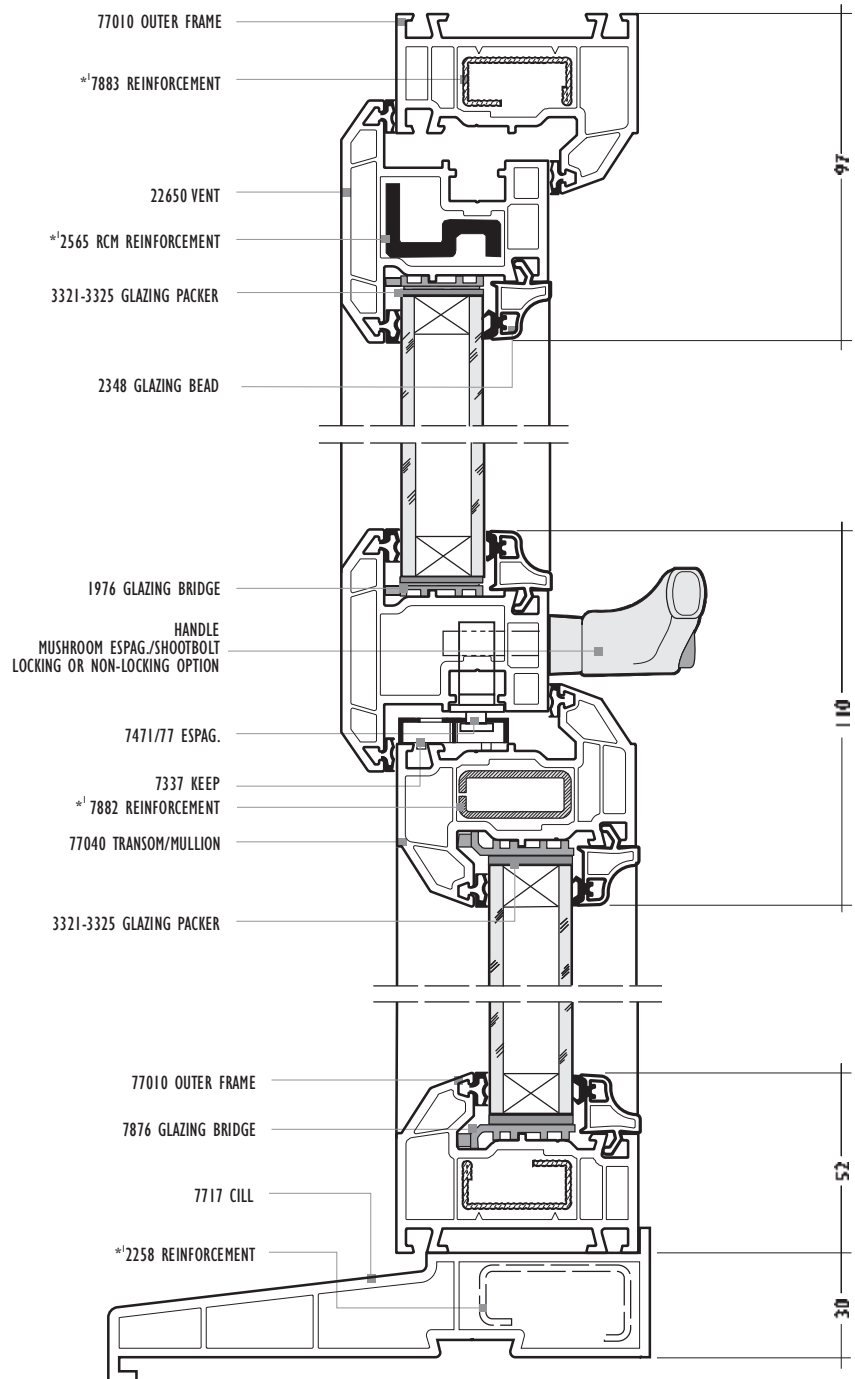

# Fully Integrated 70mm Open-out Window Internal Glazing

CATEGORY	DESCRIPTION	STYLE
PRODUCT	ASSEMBLIES	CASEMENT WINDOW

## Fully Integrated 70mm

- Open Out Window  
Std Outer Frame/Std Transom
- Fully Integrated
- 28mm Double Glazing
- Internally Glazed  
White Gasket
- Bubblex Seals

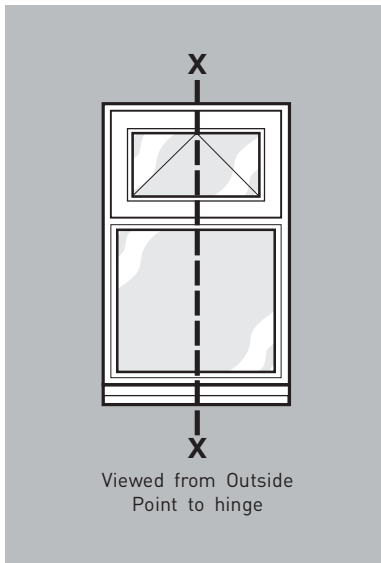

**\*1Note:** All reinforcements shown are for diagrammatical purposes only. For applications, please refer to the PROFILE 22 Product Catalogue.

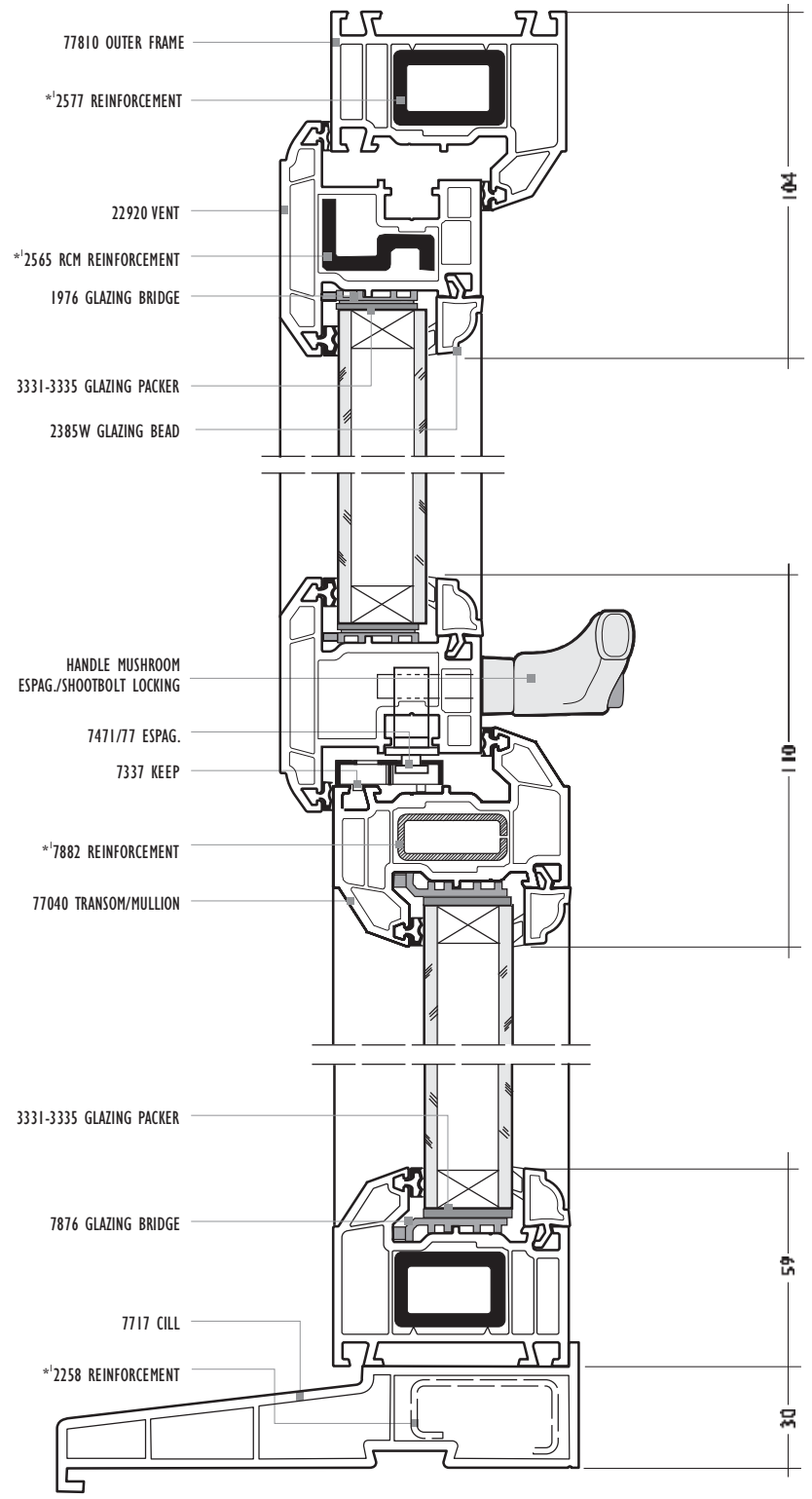

# Fully Integrated 70mm Open-out Window Internal Glazing

CATEGORY	DESCRIPTION	STYLE
PRODUCT	ASSEMBLIES	CASEMENT WINDOW

## Fully Integrated 70mm

- Open Out Window  
Large Outer Frame/Std Transom
- Fully Integrated
- 28mm Double Glazing
- Internally Glazed  
Scotia Bead
- Bubblex Seals

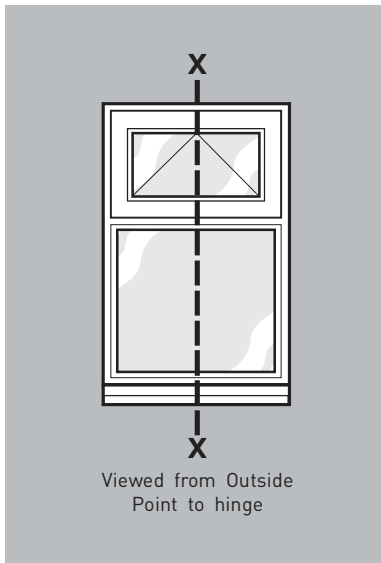

**\*1 Note:** All reinforcements shown are for diagrammatical purposes only. For applications, please refer to the PROFILE 22 Product Catalogue.

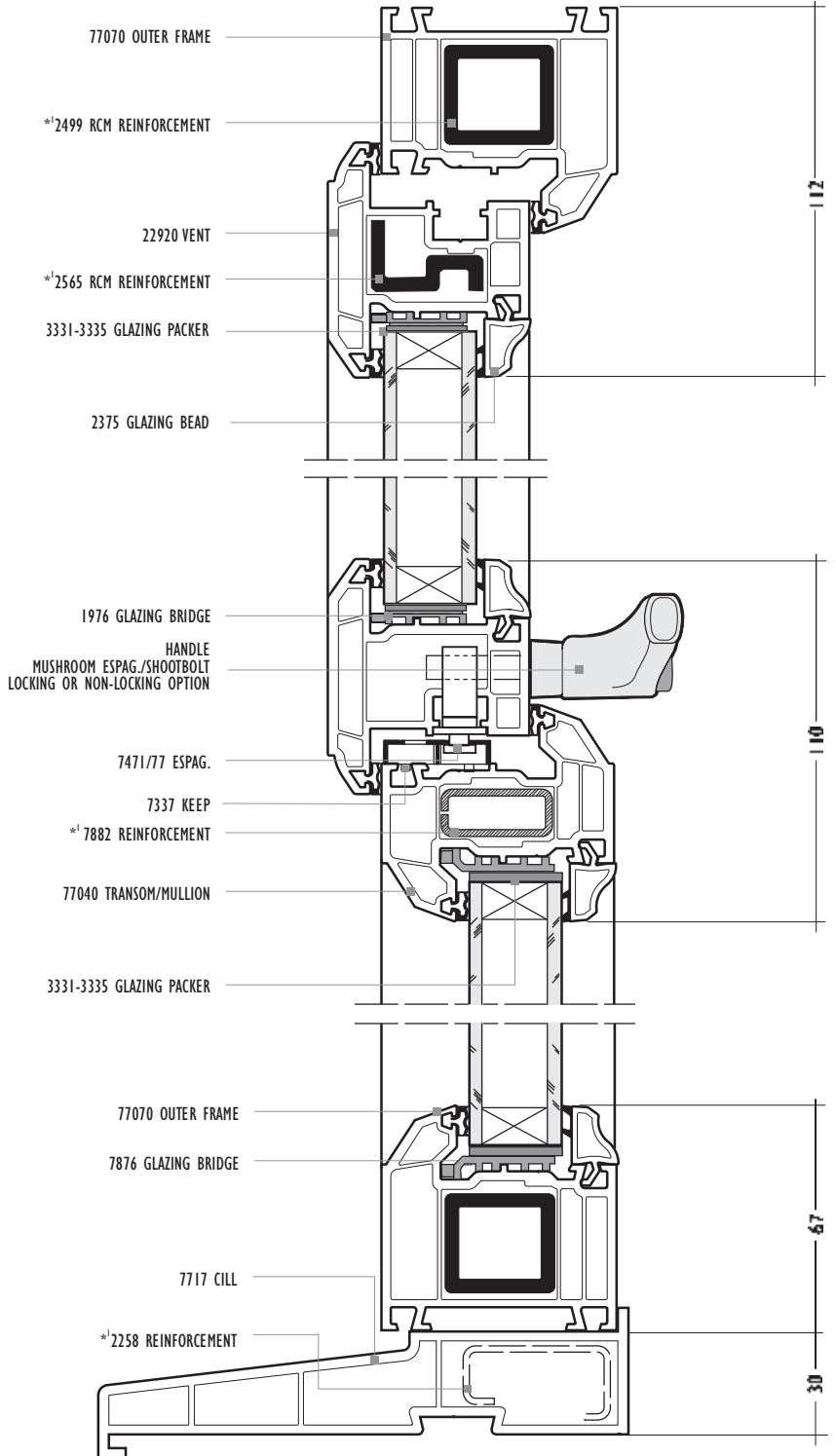

# Fully Integrated 70mm Open-out Window Internal Glazing

CATEGORY	DESCRIPTION	STYLE
PRODUCT	ASSEMBLIES	CASEMENT WINDOW



## Fully Integrated 70mm



Open Out Window  
Large Outer Frame /  
Large Transom



Fully Integrated



24mm Double Glazing



Internally Glazed  
Bevelled Bead



Bubblex Seals

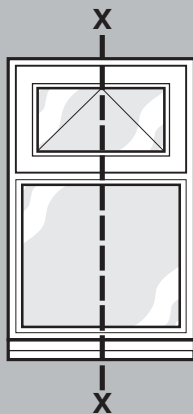

Viewed from Outside  
Point to hinge

**\*!Note:** All reinforcements shown are for diagrammatical purposes only. For applications, please refer to the PROFILE 22 Product Catalogue.

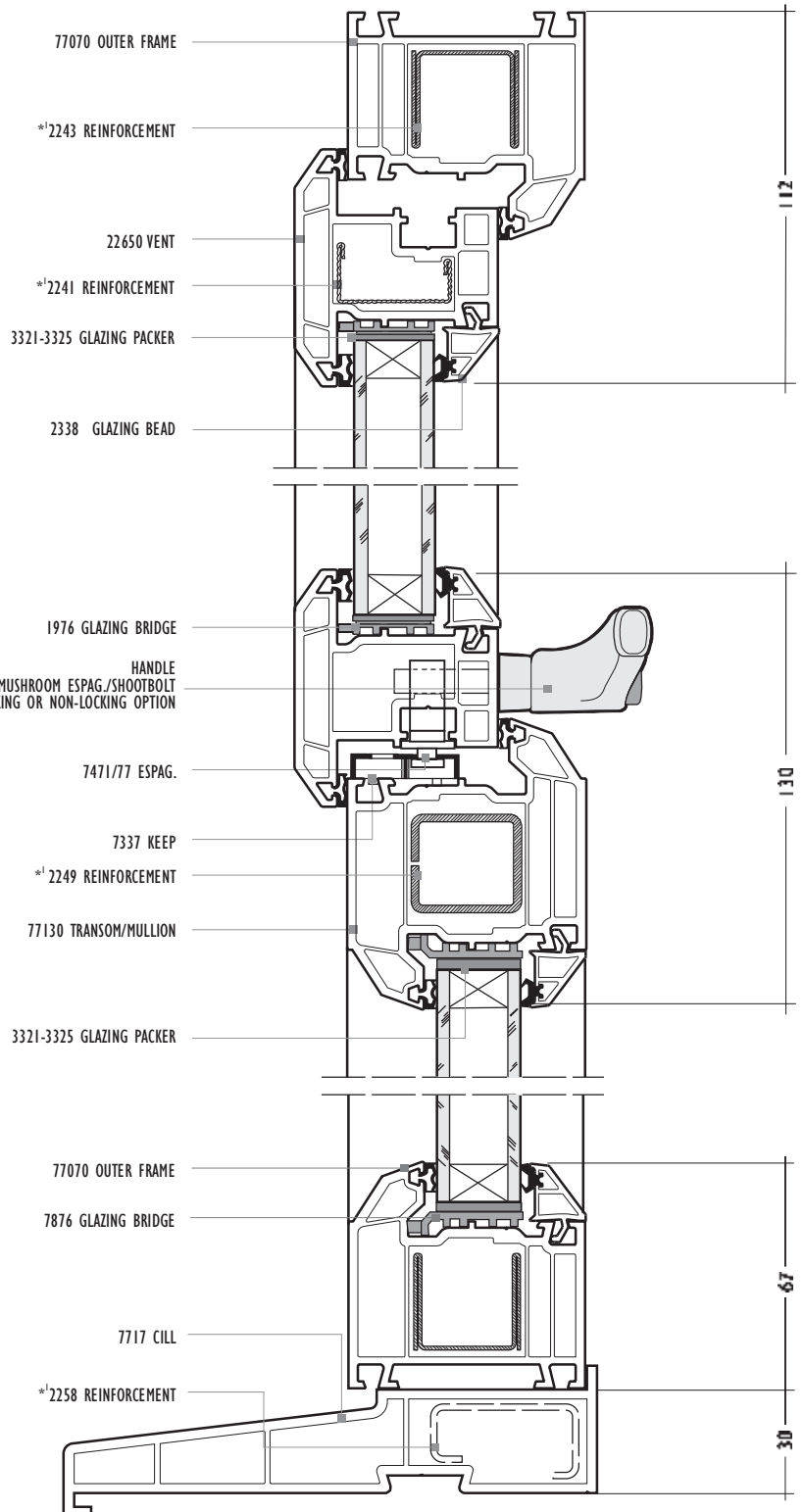

# Fully Integrated 70mm Open-out Window External Glazing

CATEGORY	DESCRIPTION	STYLE
PRODUCT	ASSEMBLIES	CASEMENT WINDOW



## Fully Integrated 70mm



Open Out Window  
Slim Outer Frame /  
Std Transom



Fully Integrated



24mm Double Glazing



Externally Glazed  
Ovolo Bead



Bubblex Seals

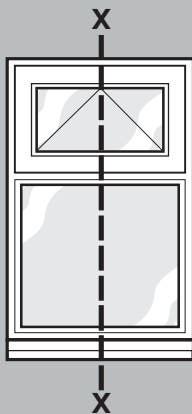

Viewed from Outside  
Point to hinge

**\*Note:** All reinforcements shown are for diagrammatical purposes only. For applications, please refer to the PROFILE 22 Product Catalogue.

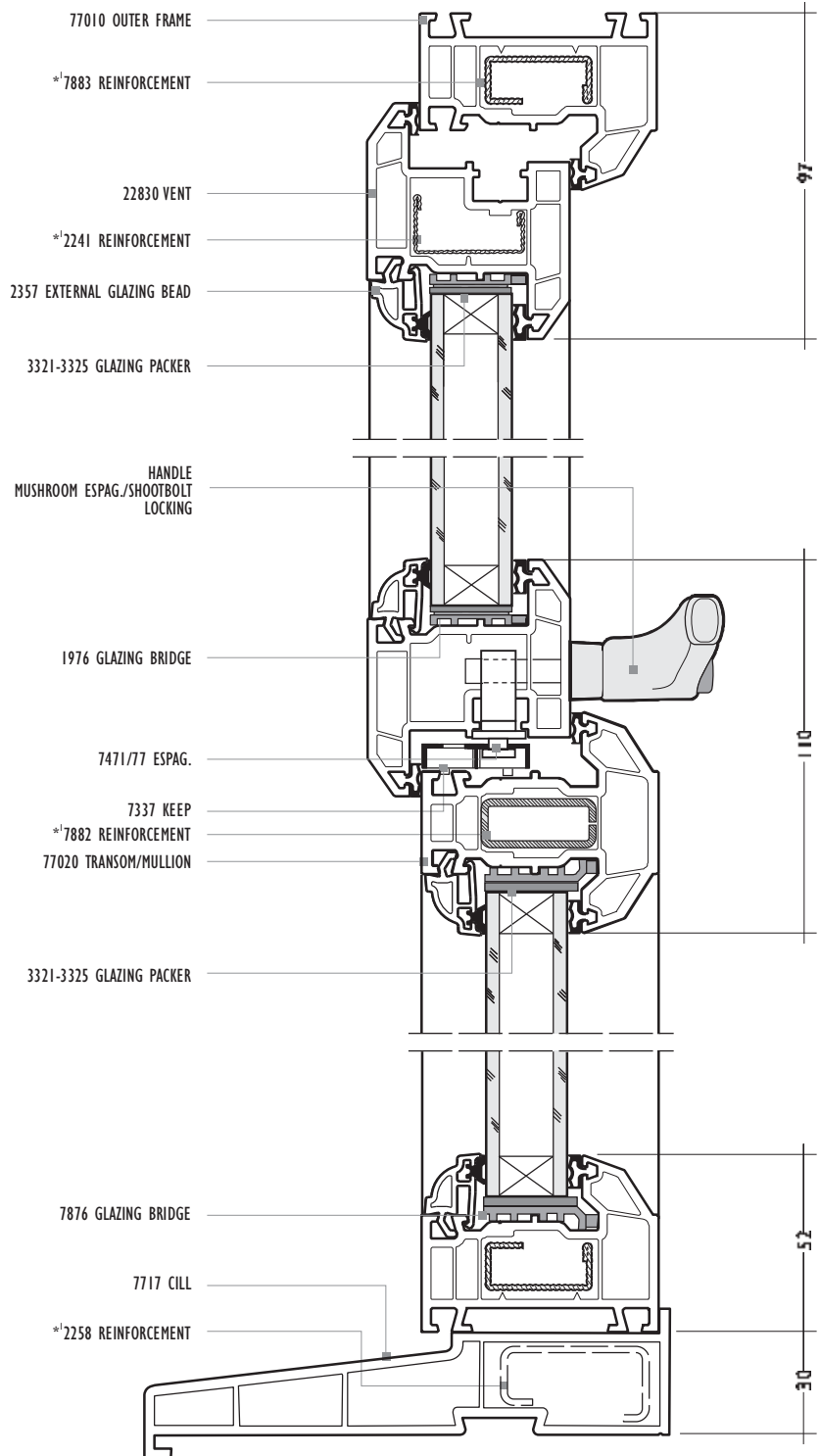



# Fully Integrated 70mm Open-out Window External Glazing

CATEGORY	DESCRIPTION	STYLE
PRODUCT	ASSEMBLIES	CASEMENT WINDOW



## Fully Integrated 70mm

-  Open Out Window  
Std Outer Frame /  
Std Transom
-  Fully Integrated
-  24mm Double Glazing
-  Externally Glazed  
Ovolo Bead
-  Bubblex Seals

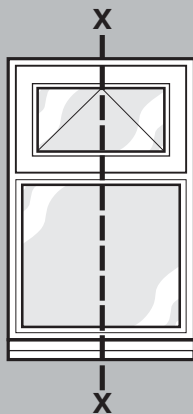

Viewed from Outside  
Point to hinge

**\*!Note:** All reinforcements shown are for diagrammatical purposes only. For applications, please refer to the PROFILE 22 Product Catalogue.

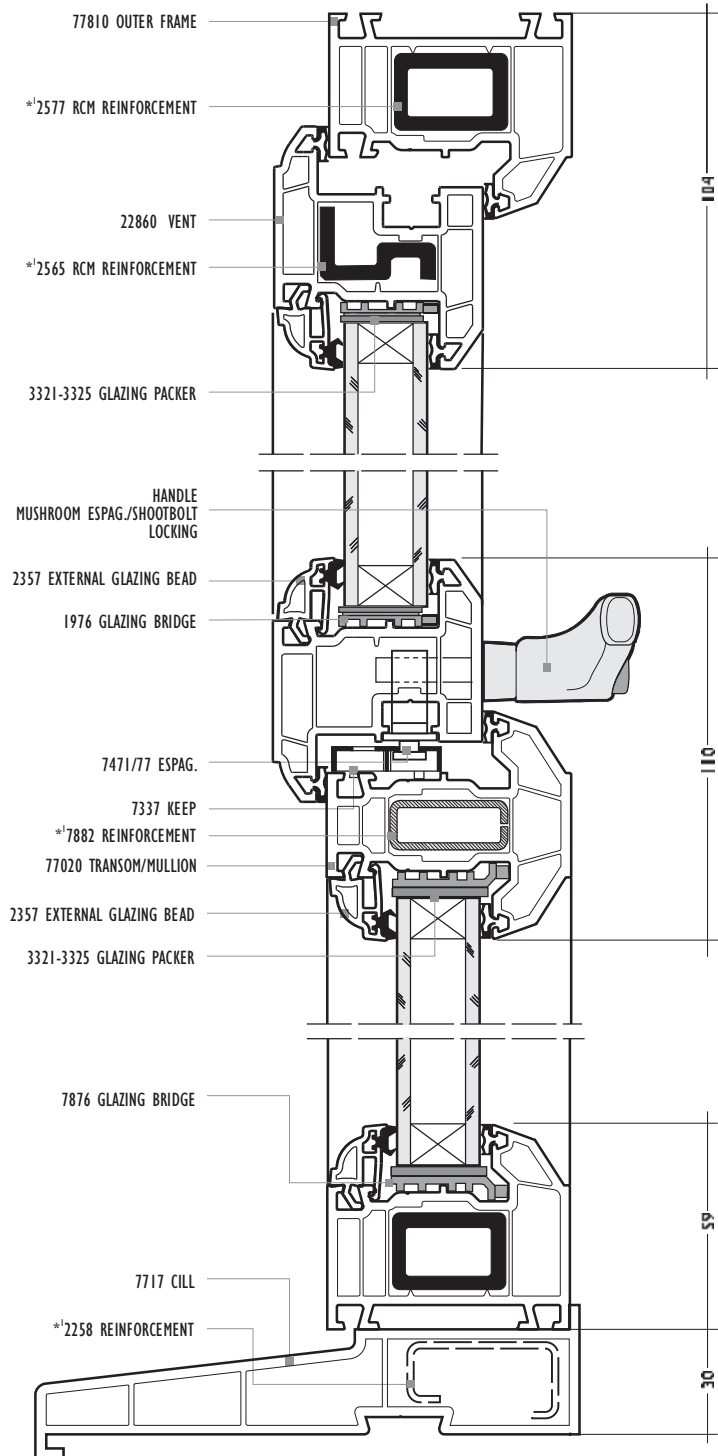

# Fully Integrated 70mm Open-out Window External Glazing

CATEGORY	DESCRIPTION	STYLE
PRODUCT	ASSEMBLIES	CASEMENT WINDOW



## Fully Integrated 70mm

-  Open Out Window  
Slim Outer Frame / Std Transom
-  Fully Integrated
-  24mm Double Glazing
-  Externally Glazed  
Bevelled Bead
-  Security Clips  
Enhanced Security
-  Bubblex Gasket

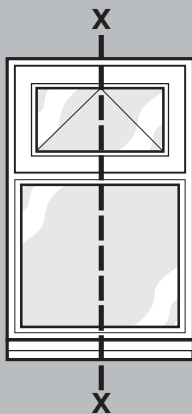

Viewed from Outside  
Point to hinge

**\*!Note:** All reinforcements shown are for diagrammatical purposes only. For applications, please refer to the PROFILE 22 Product Catalogue.

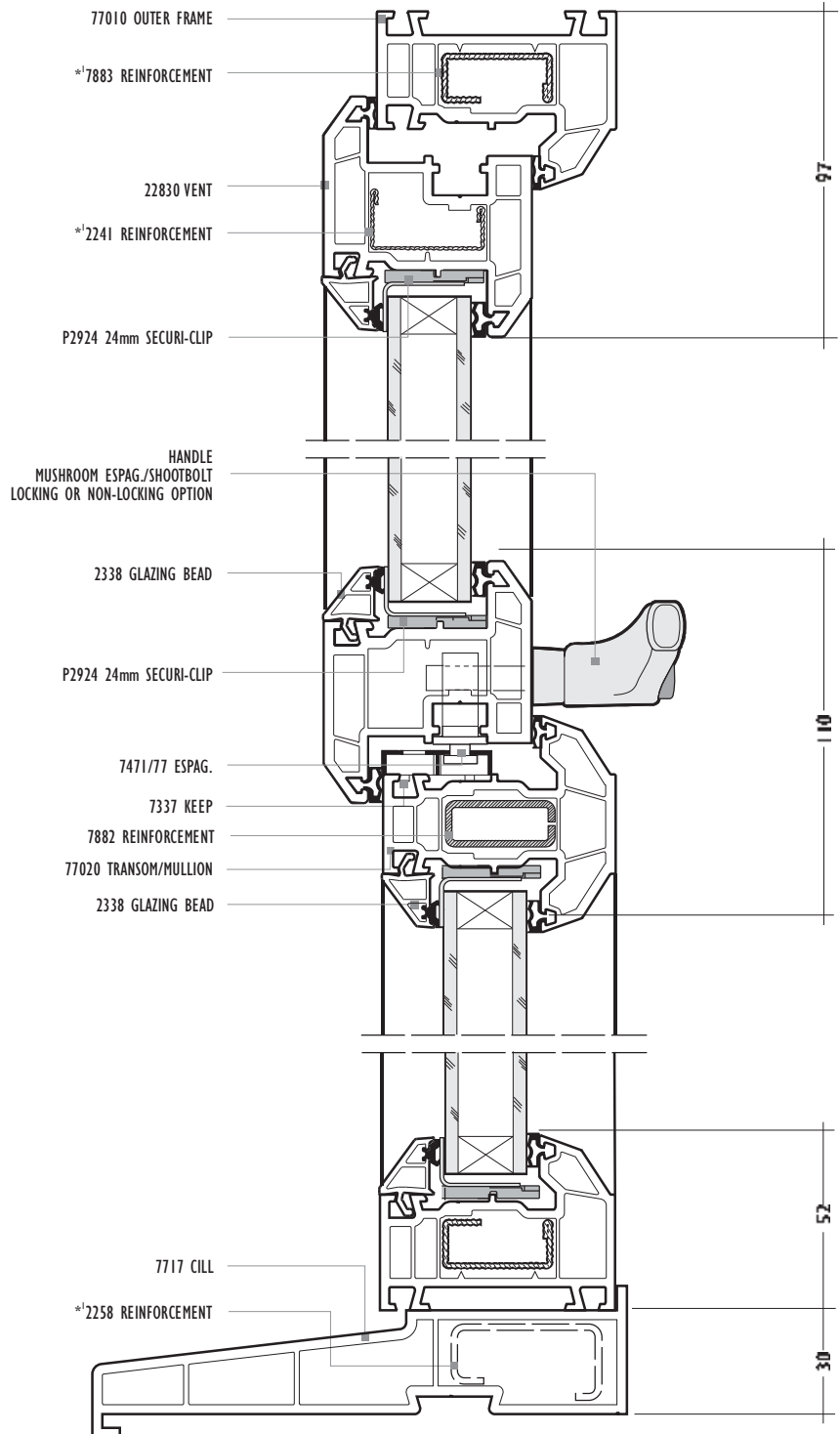

# Fully Bevelled 70mm Open-out Window Internal Glazing

CATEGORY	DESCRIPTION	STYLE
PRODUCT	ASSEMBLIES	CASEMENT WINDOW



## Fully Bevelled 70mm

-  Open Out Window  
Std Outer Frame /  
Std Transom
-  Fully Bevelled
-  28mm Double Glazing
-  Internally Glazed  
Bevelled Feature Bead
-  Bubblex Seals

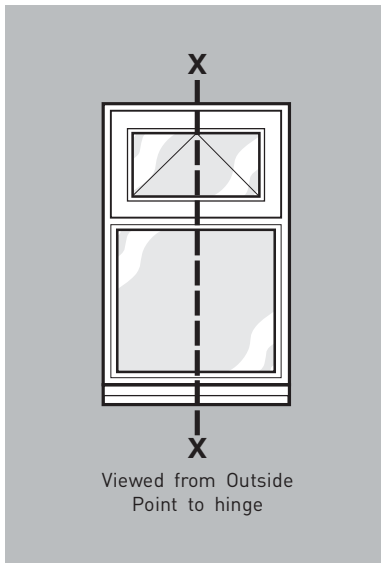



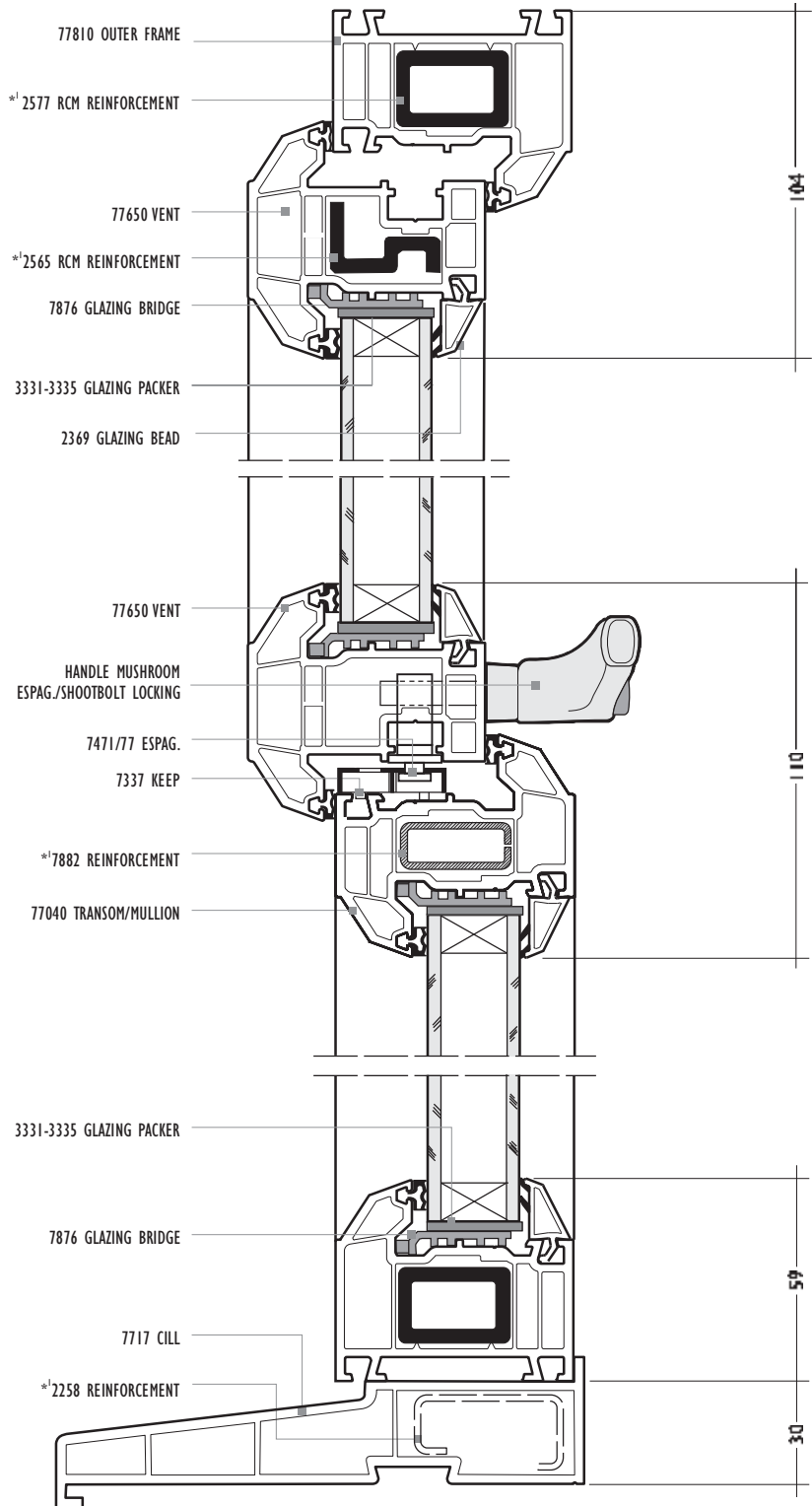

**\*1 Note:** All reinforcements shown are for diagrammatical purposes only. For applications, please refer to the PROFILE 22 Product Catalogue.



# Fully Bevelled 70mm Open-out Window Internal Glazing

CATEGORY	DESCRIPTION	STYLE
PRODUCT	ASSEMBLIES	CASEMENT WINDOW

## Fully Bevelled 70mm

-  Open Out Window  
Large Outer Frame /  
Large Transom
-  Fully Bevelled
-  28mm Double Glazing
-  Internally Glazed  
Bevelled Feature Bead
-  Bubblex Seals

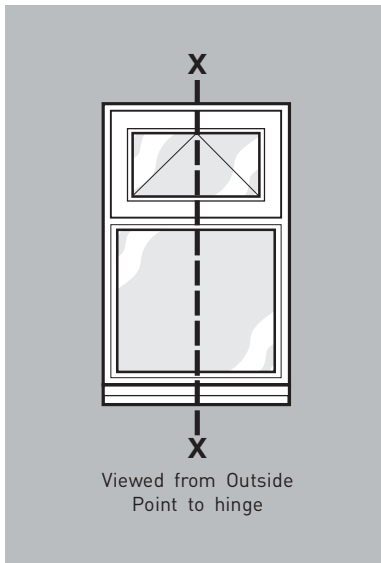

**\*!Note:** All reinforcements shown are for diagramatical purposes only. For applications, please refer to the PROFILE 22 Product Catalogue.

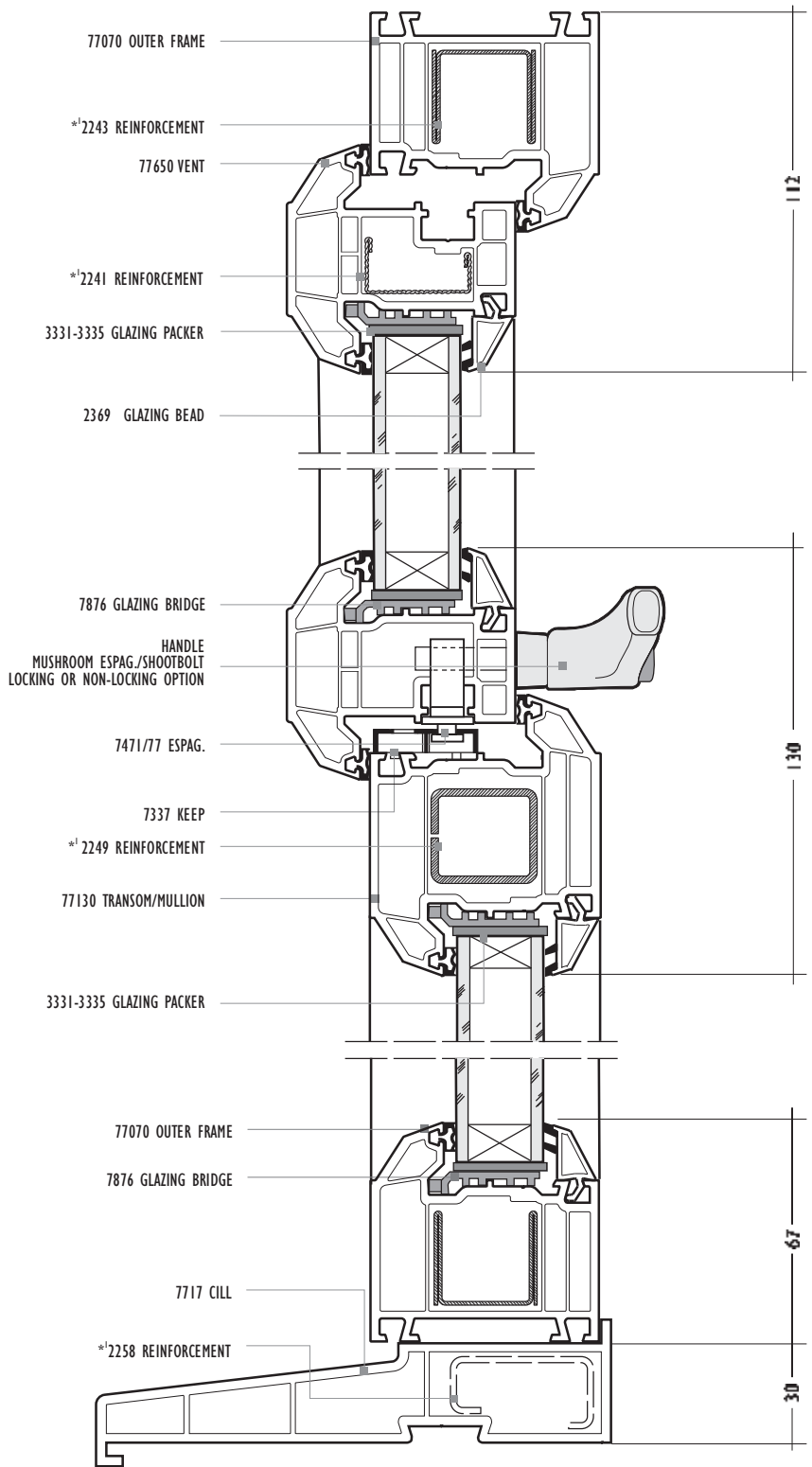

# Fully Sculptured 70mm Open-out Window Internal Glazing

CATEGORY	DESCRIPTION	STYLE
PRODUCT	ASSEMBLIES	CASEMENT WINDOW



## Fully Sculptured 70mm

Open Out Window  
Std Outer Frame/Std Transom

Fully Sculptured

28mm Double Glazing

Internally Glazed  
Sculptured Feature Bead

Bubblex Seals

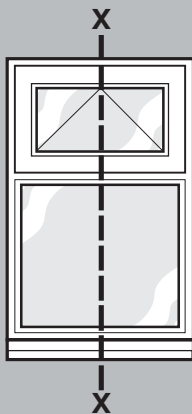

Viewed from Outside  
Point to hinge

**\*1 Note:** All reinforcements shown are for diagrammatical purposes only. For applications, please refer to the PROFILE 22 Product Catalogue.

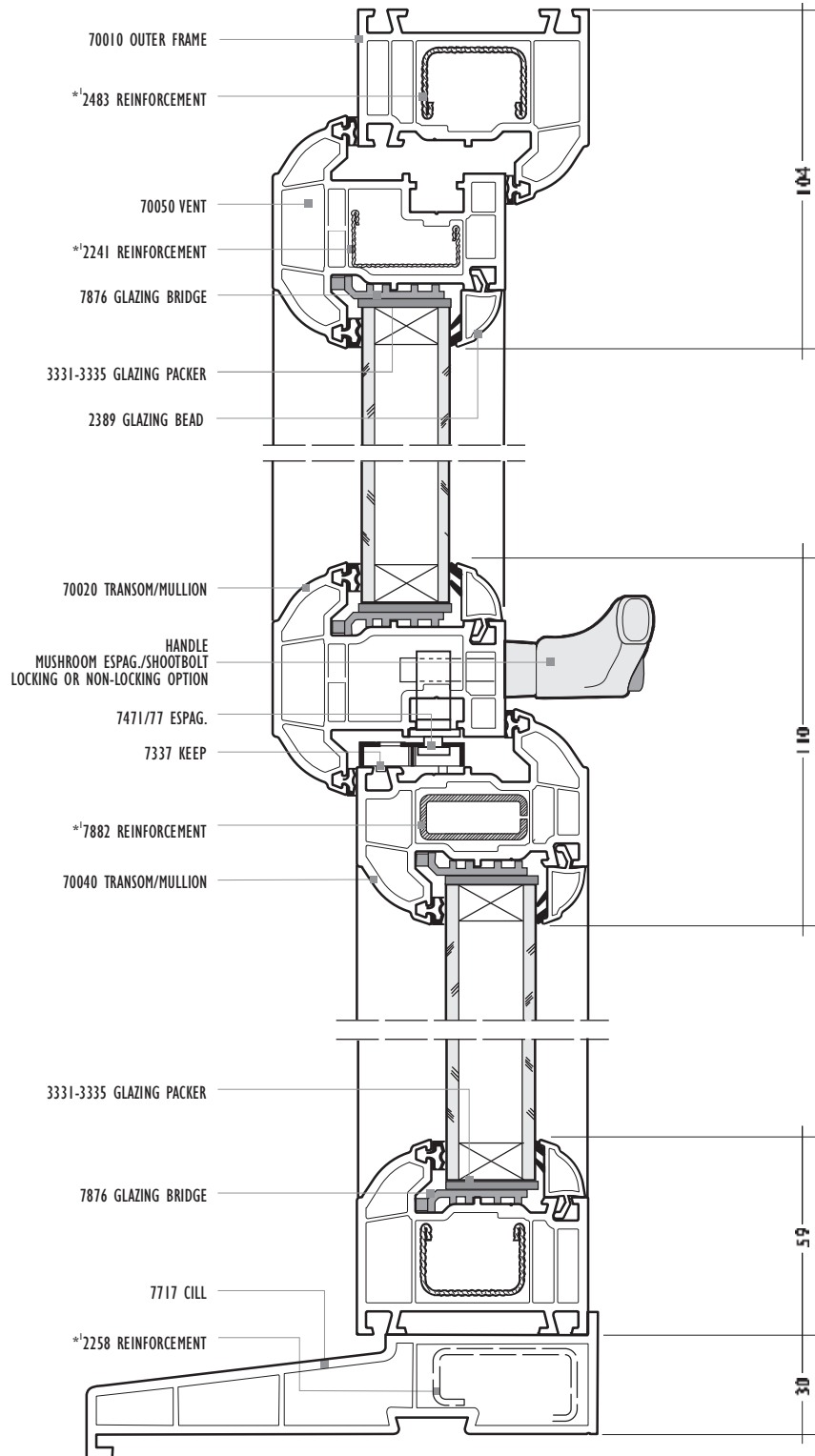

# Fully Sculptured 70mm Open-out Window Internal Glazing

CATEGORY	DESCRIPTION	STYLE
PRODUCT	ASSEMBLIES	CASEMENT WINDOW



## Fully Sculptured 70mm

-  Open Out Window  
Large Outer Frame /  
Large Transom
-  Fully Sculptured
-  28mm Double Glazing
-  Internally Glazed  
Sculptured Feature Bead
-  Bubblex Seals

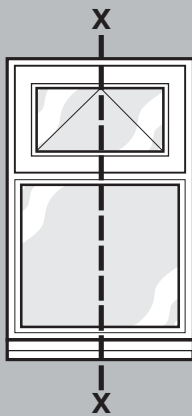

Viewed from Outside  
Point to hinge

**\*!Note:** All reinforcements shown are for diagrammatical purposes only. For applications, please refer to the PROFILE 22 Product Catalogue.

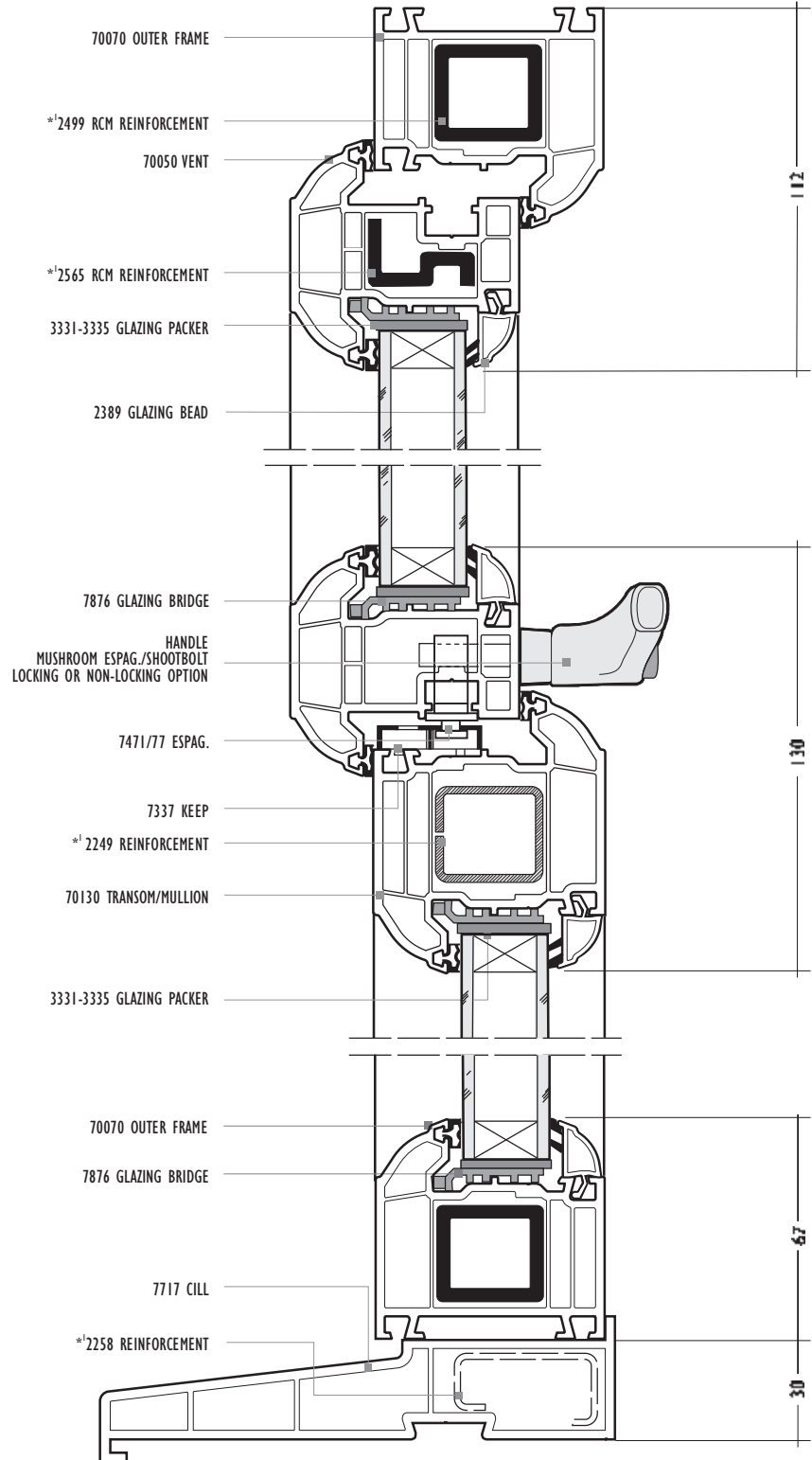

# 1 Product



## Window Styles

Tilt-Turn Window



# Fully Chamfered 60mm Open-In Tilt-Turn Window Internal Glazing

CATEGORY	DESCRIPTION	STYLE
PRODUCT	ASSEMBLIES	TILT-TURN WINDOW

## Fully Chamfered 60mm

- Tilt - Turn Open In Window
- Fully Chamfered
- 24mm Double Glazing
- Internally Glazed
- Bubblax Seals

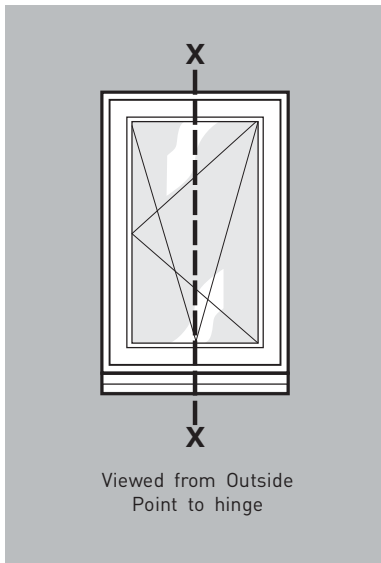

**\*!Note:** All reinforcements shown are for diagrammatical purposes only. For applications, please refer to the PROFILE 22 Product Catalogue.

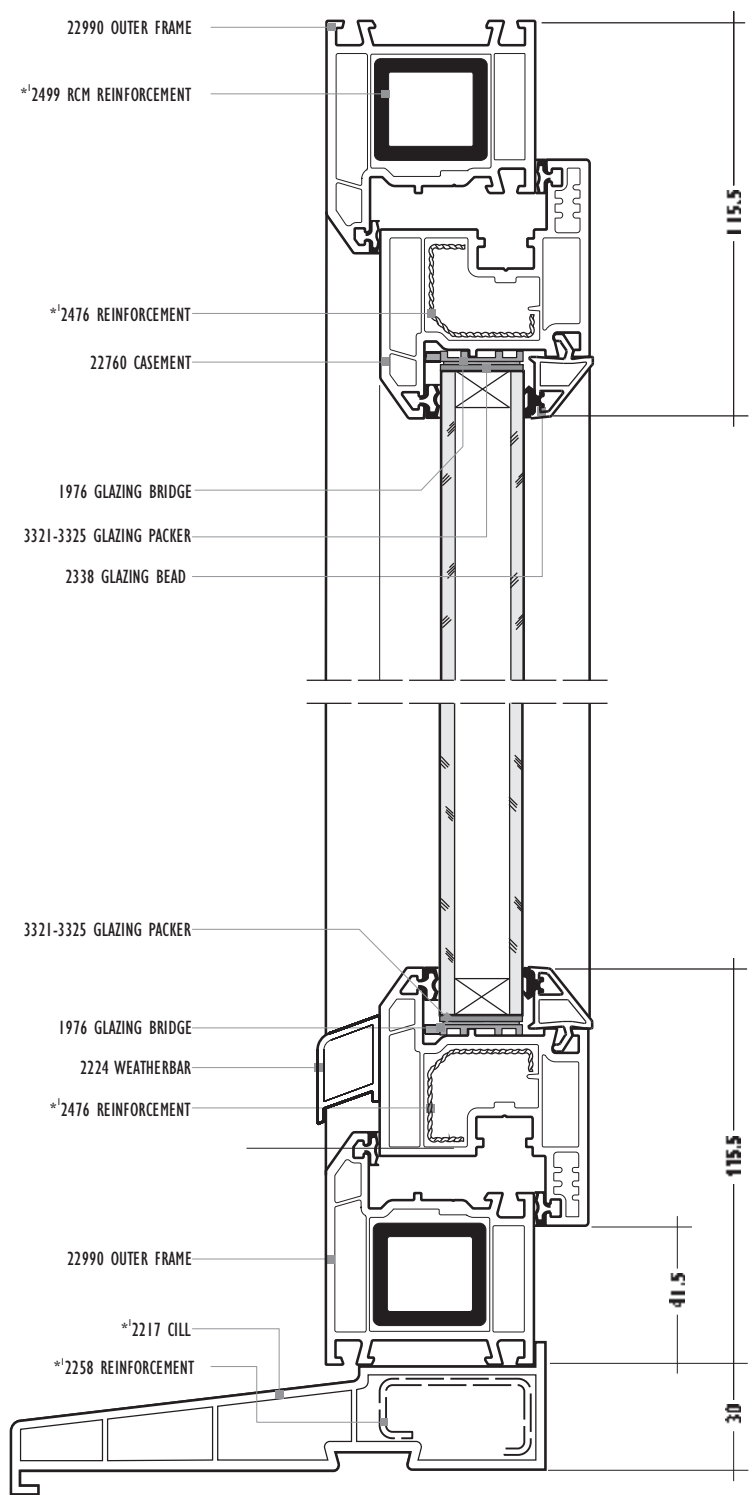



# Fully Integrated 70mm Open-in Tilt-Turn Window Internal Glazing

CATEGORY	DESCRIPTION	STYLE
PRODUCT	ASSEMBLIES	TILT-TURN WINDOW

## Fully Integrated 70mm

- Tilt - Turn Open In Window
- Fully Integrated
- 28mm Double Glazing
- Internally Glazed  
Ovolo Bead
- Bubblex Seals

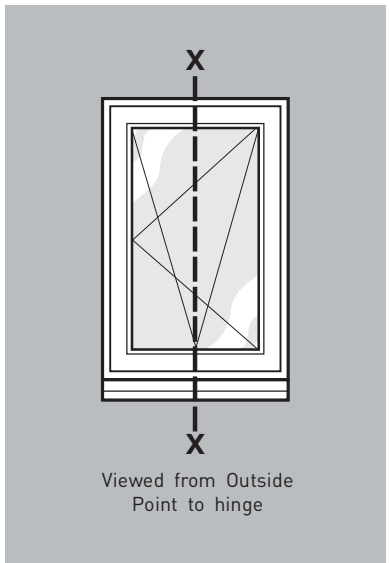

**\*!Note:** All reinforcements shown are for diagrammatical purposes only. For applications, please refer to the PROFILE 22 Product Catalogue.

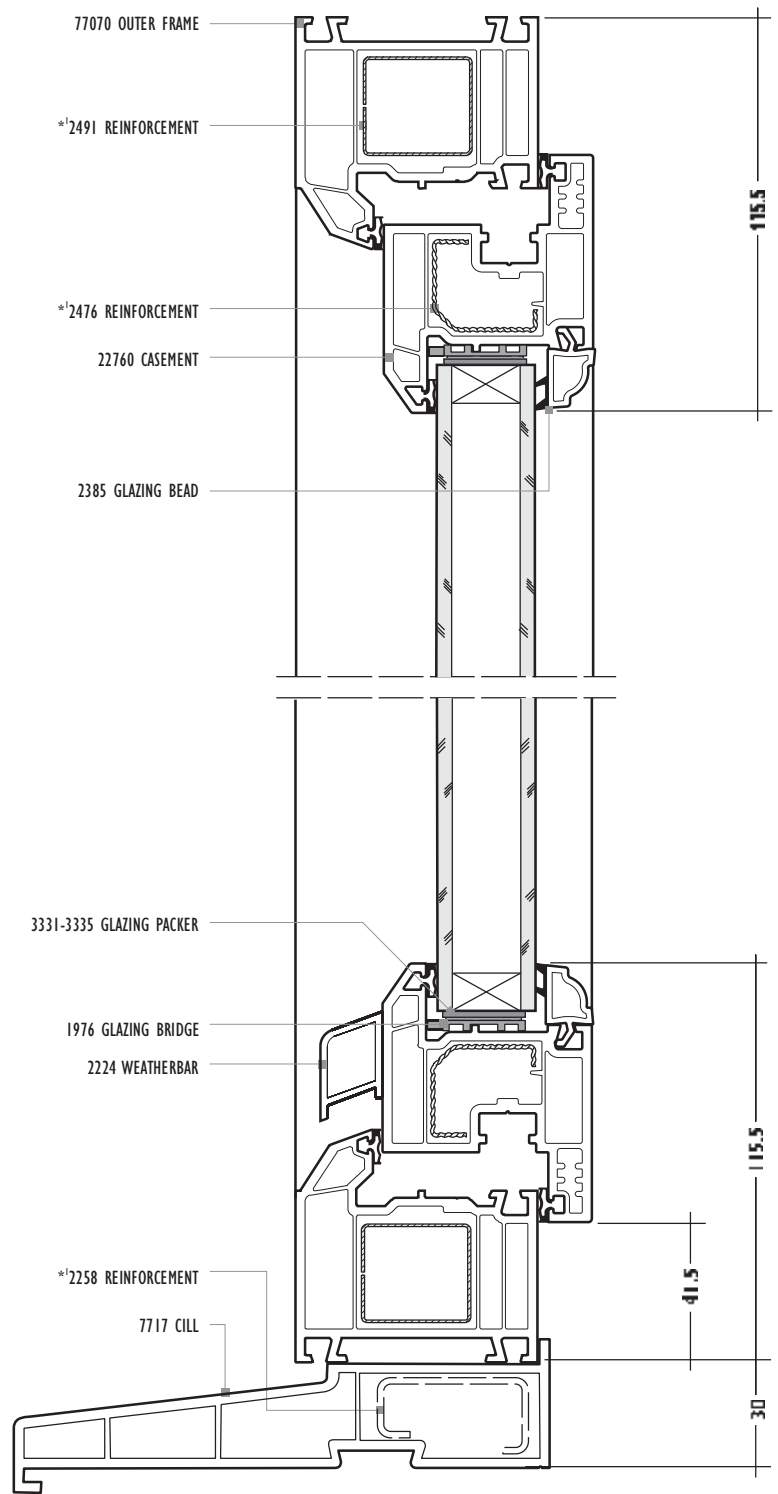

# Fully Bevelled 70mm Open-In Tilt-Turn Window Internal Glazing

CATEGORY	DESCRIPTION	STYLE
PRODUCT	ASSEMBLIES	TILT-TURN WINDOW



## Fully Bevelled 70mm



Tilt - Turn Open In Window



Fully Bevelled



28mm Double Glazing



Internally Glazed  
Bevelled Feature Bead



Bubblex Seals

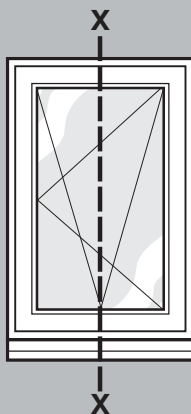

Viewed from Outside  
Point to hinge

**\*!Note:** All reinforcements shown are for diagrammatical purposes only. For applications, please refer to the PROFILE 22 Product Catalogue.

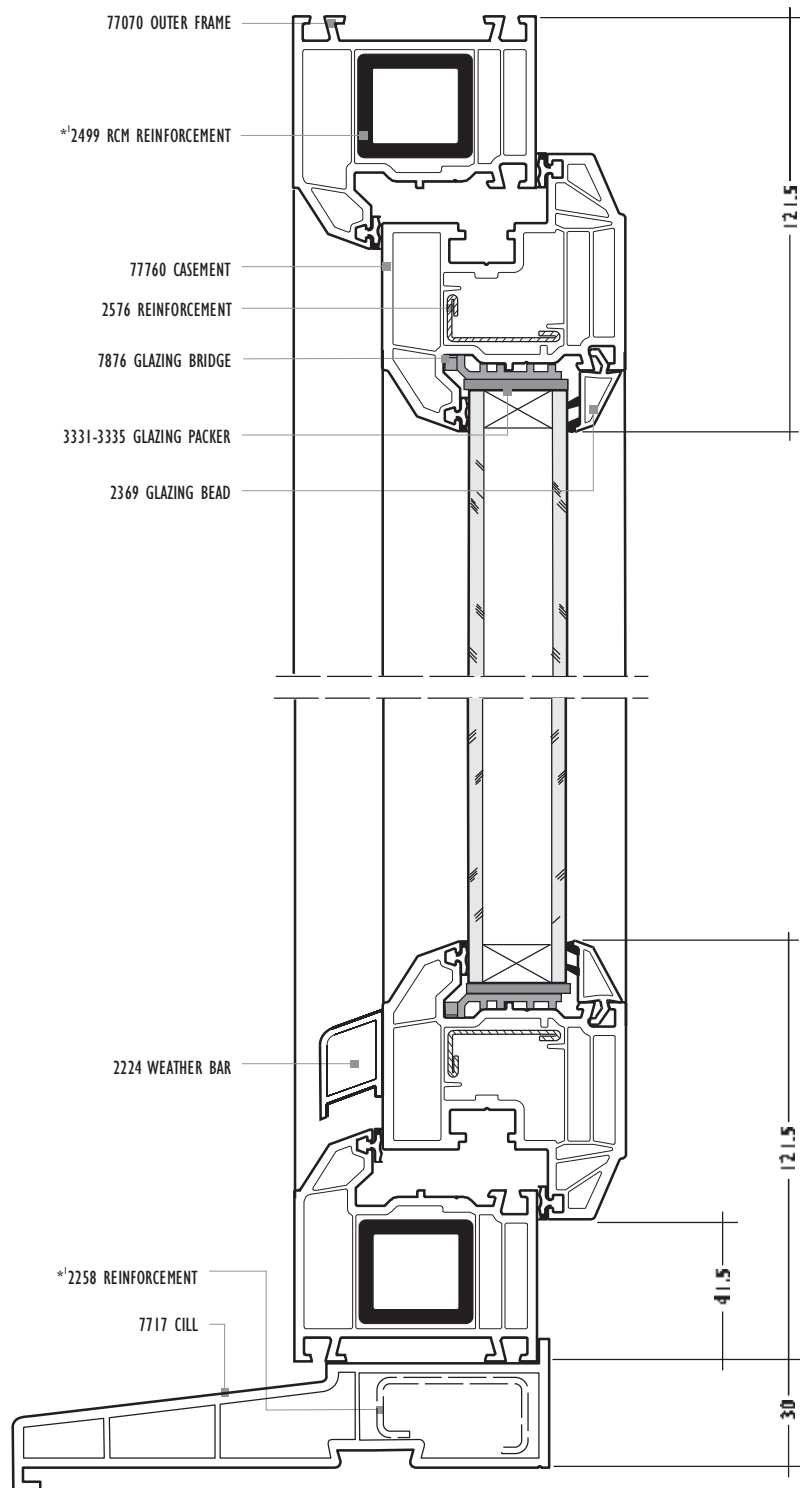

# Fully Sculptured 70mm Open-in Tilt-Turn Window Internal Glazing

CATEGORY	DESCRIPTION	STYLE
PRODUCT	ASSEMBLIES	TILT-TURN WINDOW



## Fully Sculptured 70mm

- Tilt - Turn Open In Window
- Fully Sculptured
- 28mm Double Glazing
- Internally Glazed  
Sculptured Feature Bead
- Bubblex Seals

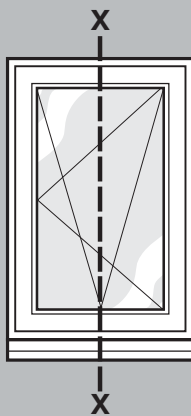

Viewed from Outside  
Point to hinge

**\*1 Note:** All reinforcements shown are for diagrammatical purposes only. For applications, please refer to the PROFILE 22 Product Catalogue.

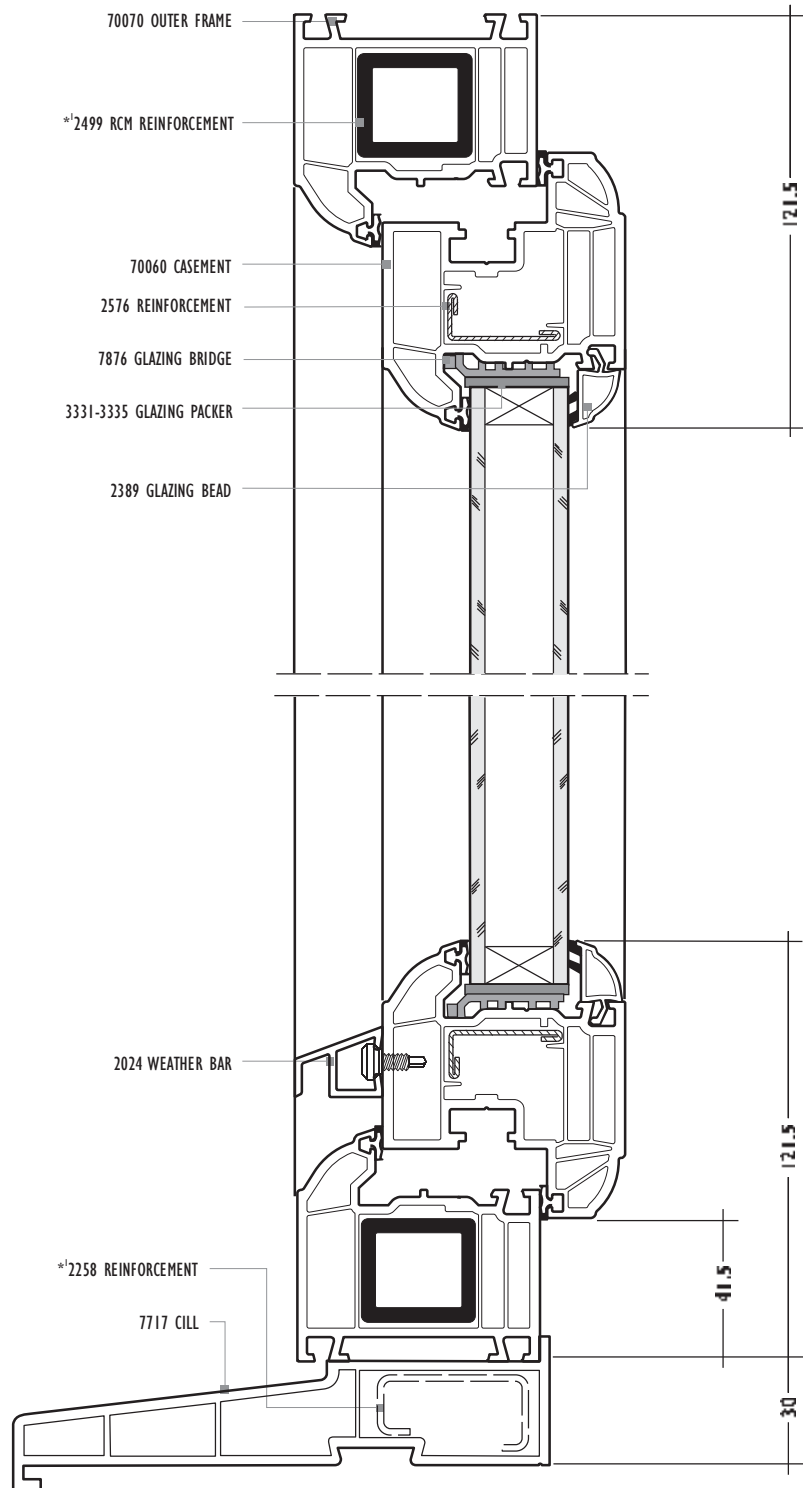

# 1 Product



## Window Styles

### Horizontal Pivot Window



# Fully Chamfered 60mm Horizontal Pivot Window Internal Glazing

CATEGORY	DESCRIPTION	STYLE
PRODUCT	ASSEMBLIES	HORIZONTAL PIVOT WINDOW

## Fully Chamfered 60mm

- Horizontal Pivot Window
- Fully Chamfered
- 24mm Double Glazing
- Internally Glazed Scotiabead
- Bubblex Seals

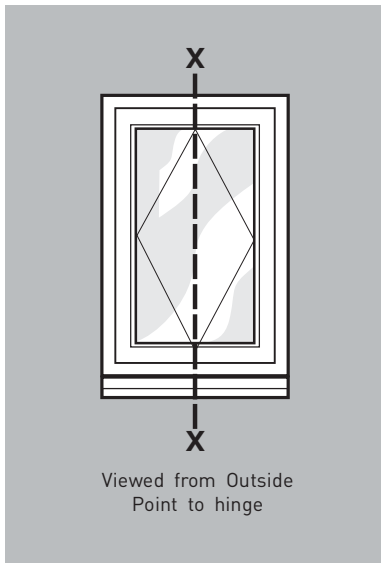

**\*!Note:** All reinforcements shown are for diagrammatical purposes only. For applications, please refer to the PROFILE 22 Product Catalogue.

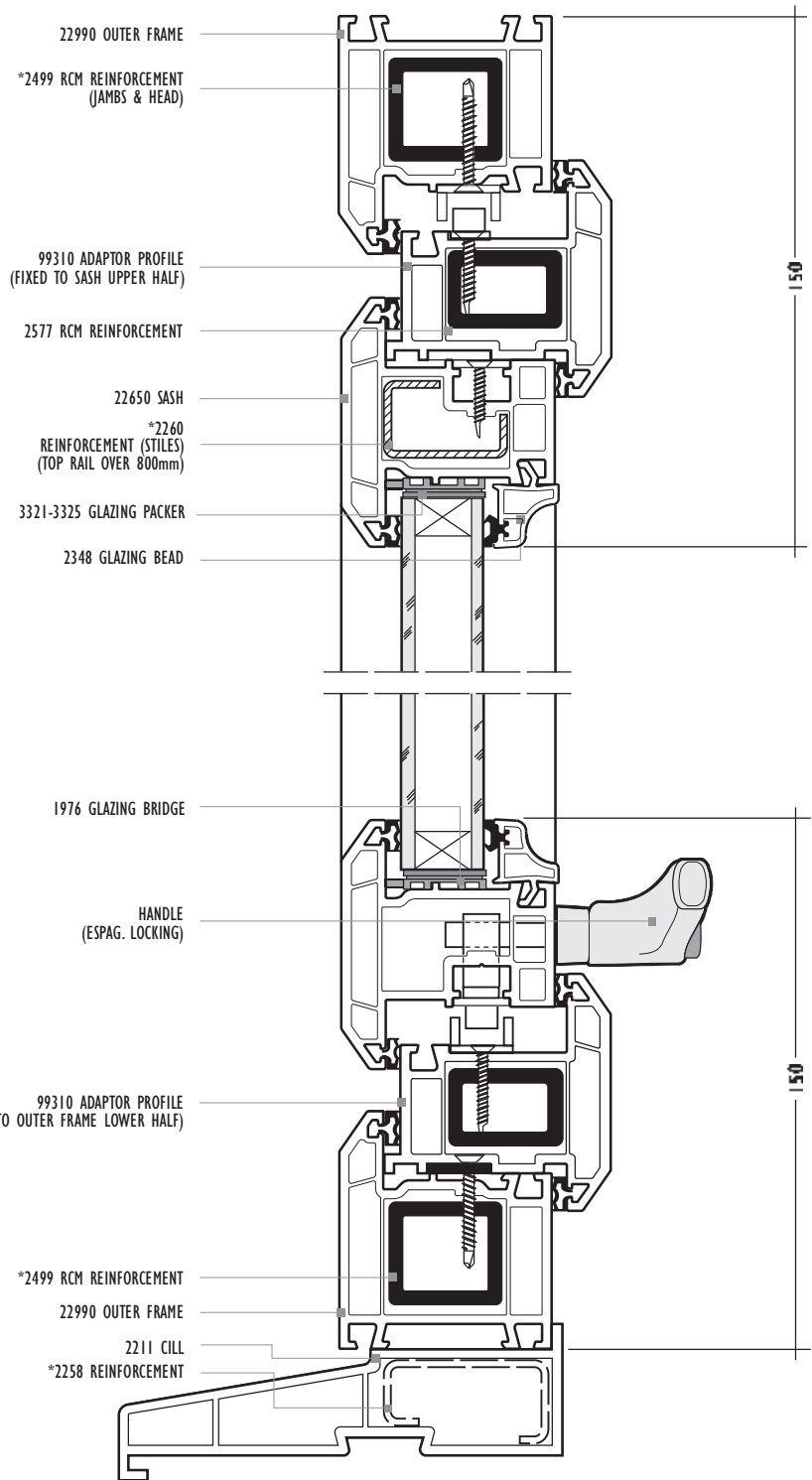

# Fully Integrated 70mm Horizontal Pivot Window Internal Glazing

CATEGORY	DESCRIPTION	STYLE
PRODUCT	ASSEMBLIES	HORIZONTAL PIVOT WINDOW



## Fully Integrated 70mm



Horizontal Pivot Window



Fully Integrated



28mm Double Glazing



Internally Glazed  
Ovolo Bead



Bubblex Seals

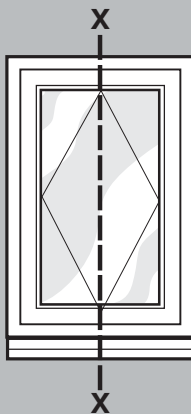

Viewed from Outside  
Point to hinge

**\*!Note:** All reinforcements shown are for diagrammatical purposes only. For applications, please refer to the PROFILE 22 Product Catalogue.

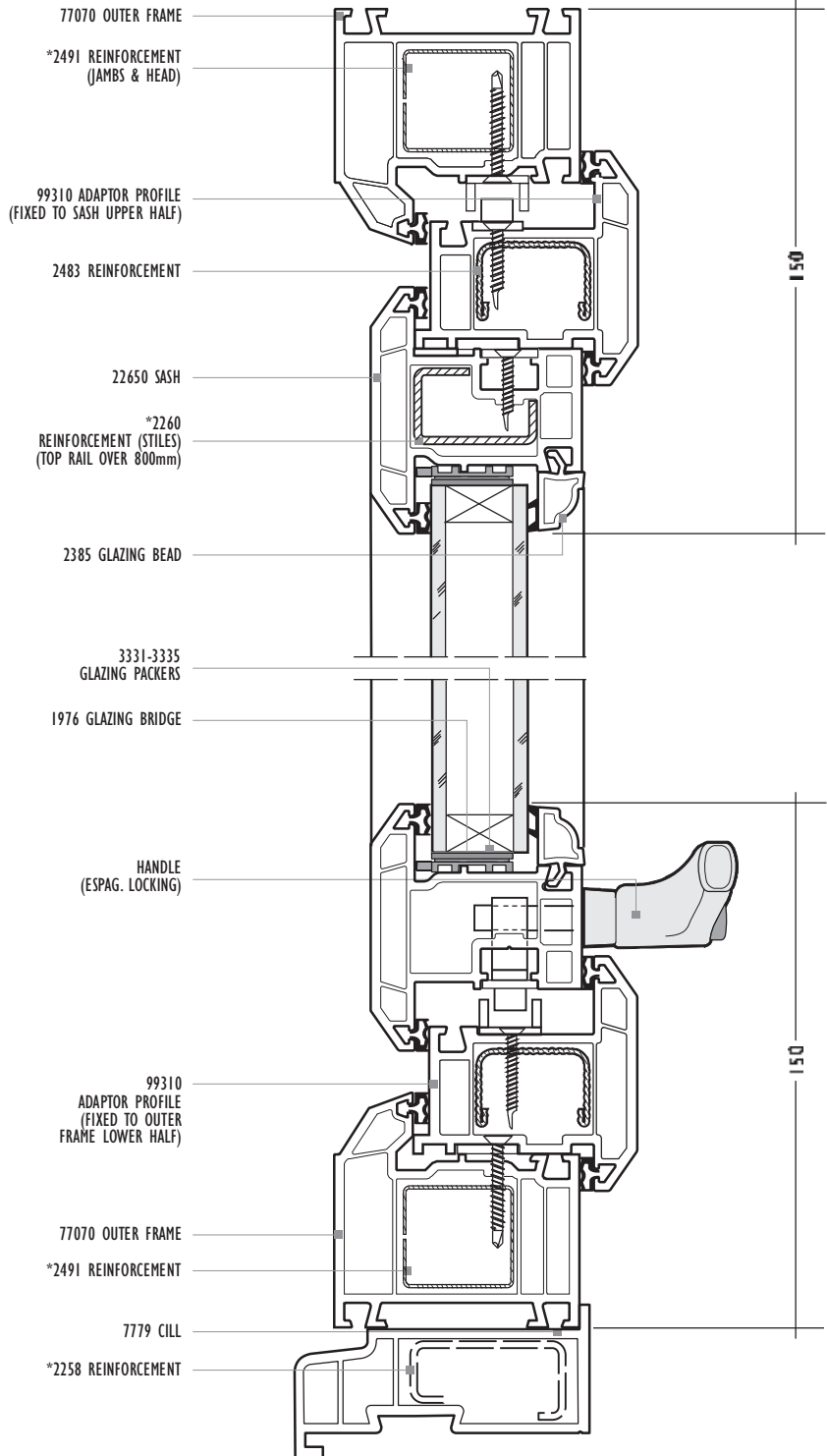

# Fully Bevelled 70mm Horizontal Pivot Window Internal Glazing

CATEGORY	DESCRIPTION	STYLE
PRODUCT	ASSEMBLIES	HORIZONTAL PIVOT WINDOW

## Fully Bevelled 70mm

- Horizontal Pivot Window
- Fully Bevelled
- 28mm Double Glazing
- Internally Glazed Bevelled Feature Bead
- Bubblem Seals

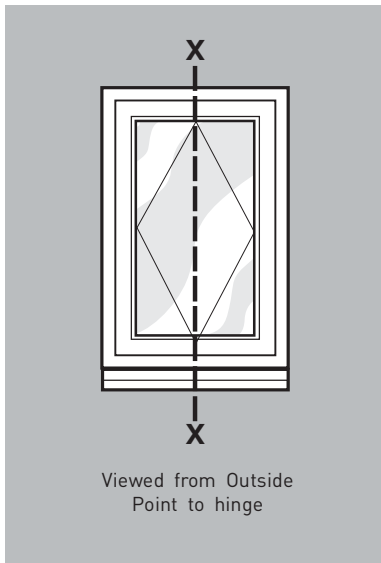

**\*!Note:** All reinforcements shown are for diagrammatical purposes only. For applications, please refer to the PROFILE 22 Product Catalogue.

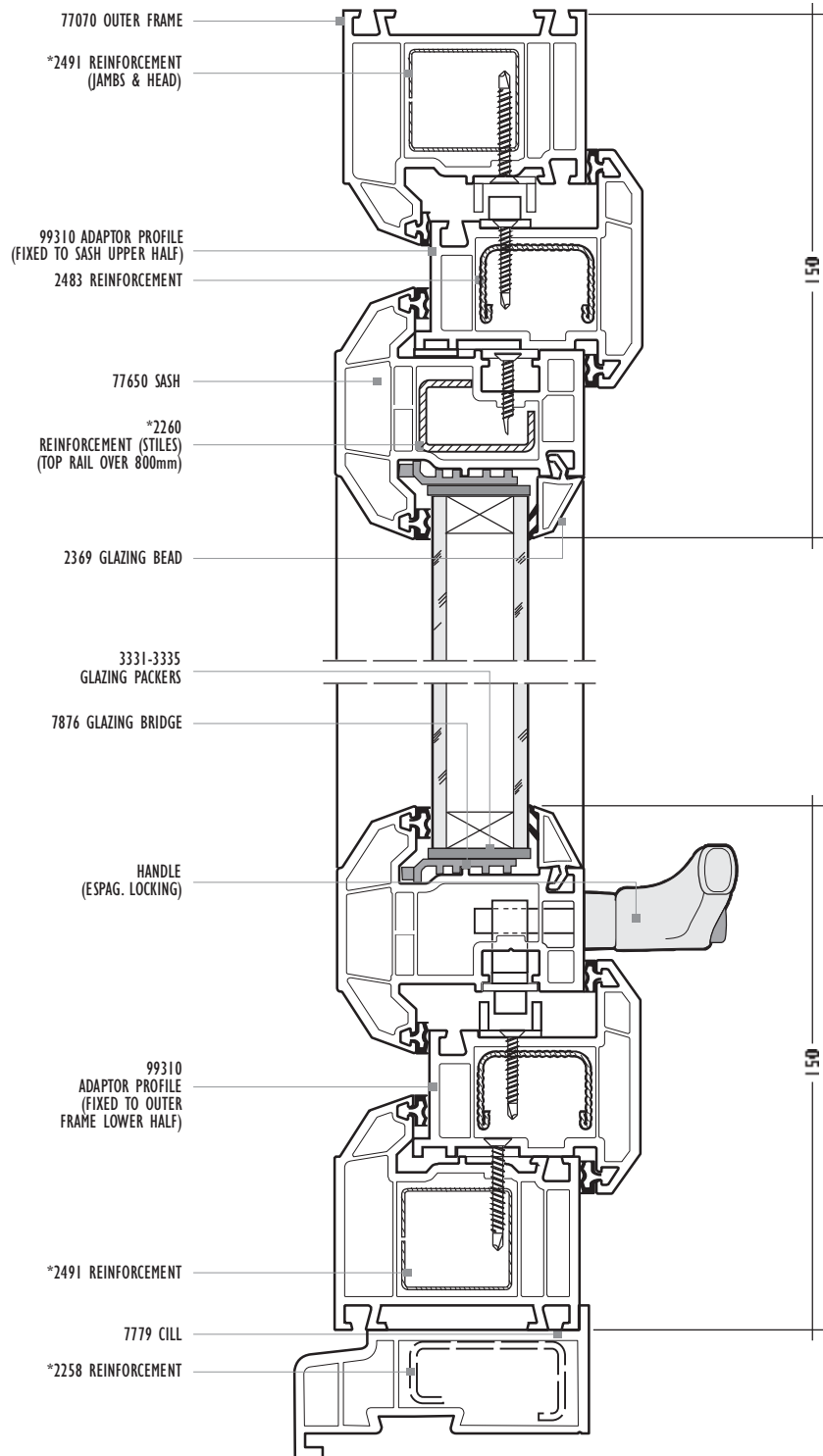

# Fully Sculptured 70mm Horizontal Pivot Window Internal Glazing

CATEGORY	DESCRIPTION	STYLE
PRODUCT	ASSEMBLIES	HORIZONTAL PIVOT WINDOW



## Fully Sculptured 70mm

- Horizontal Pivot Window
- Fully Sculptured
- 28mm Double Glazing
- Internally Glazed Sculptured Feature Bead
- Bubblex Seals

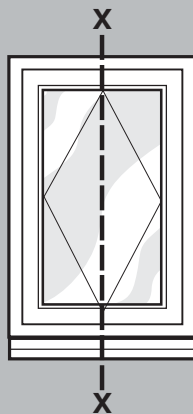

Viewed from Outside  
Point to hinge

**\*!Note:** All reinforcements shown are for diagrammatical purposes only. For applications, please refer to the PROFILE 22 Product Catalogue.

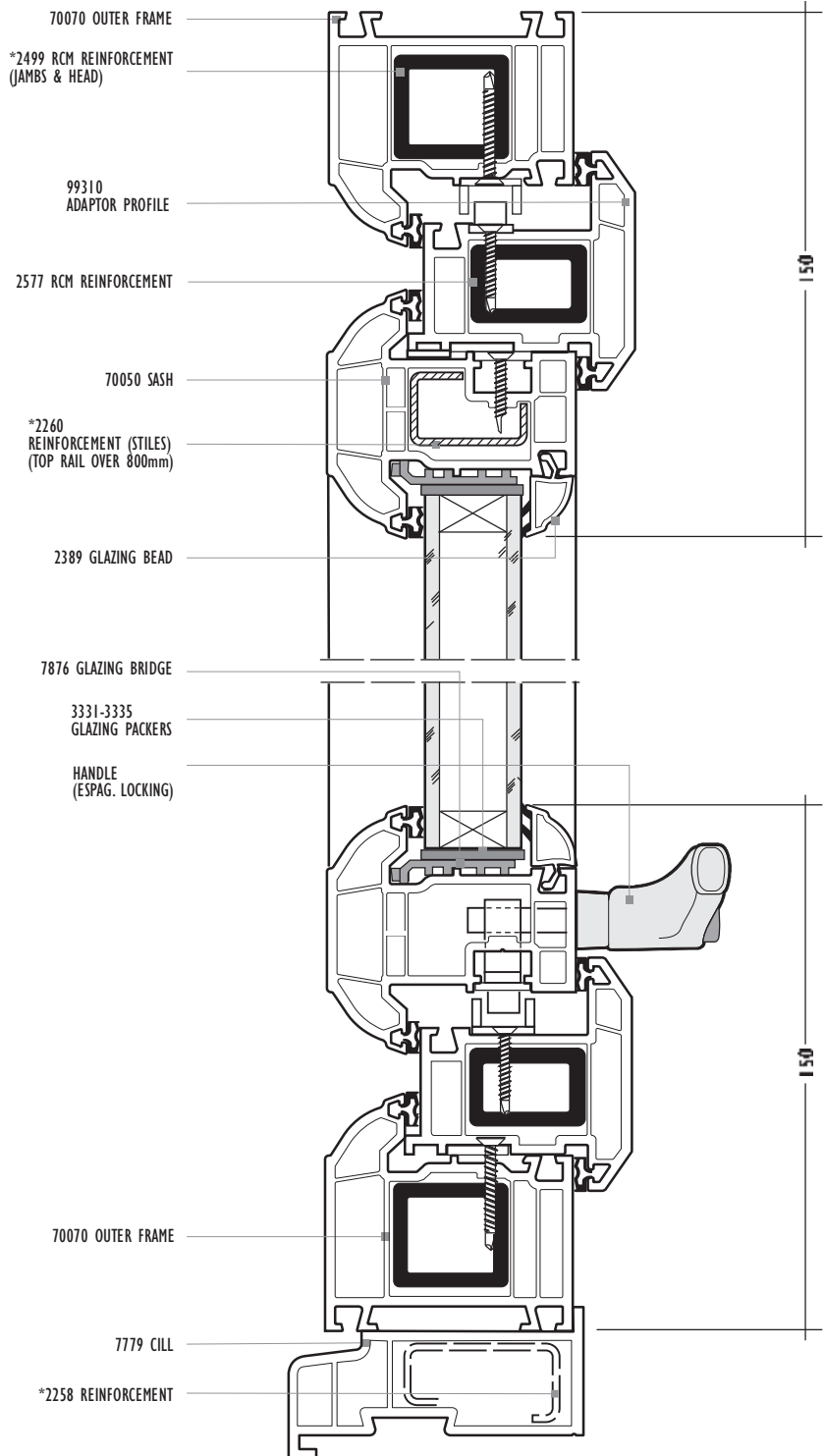



## Window Styles

Fully Reversible Window



# Fully Reversible 70mm Window Internal Glazing

CATEGORY	DESCRIPTION	STYLE
PRODUCT	ASSEMBLIES	FULLY REVERSIBLE WINDOW



## Fully Reversible 70mm



Fully Reversible Window



Fully Reversible



24mm Double Glazing



Internally Glazed Bevelled Bead

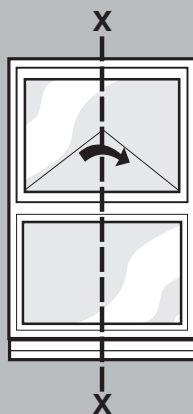

Viewed from Outside  
Point to hinge

**\*1 Note:** All reinforcements shown are for diagrammatical purposes only. For applications, please refer to the PROFILE 22 Product Catalogue.

**\*2 Note:** Detail shows 1822E gasket - on occasions where there are variances due to tolerance build up, alternative gaskets are supplied, i.e. 1808E if glass too tight, 1971 if glass too loose.

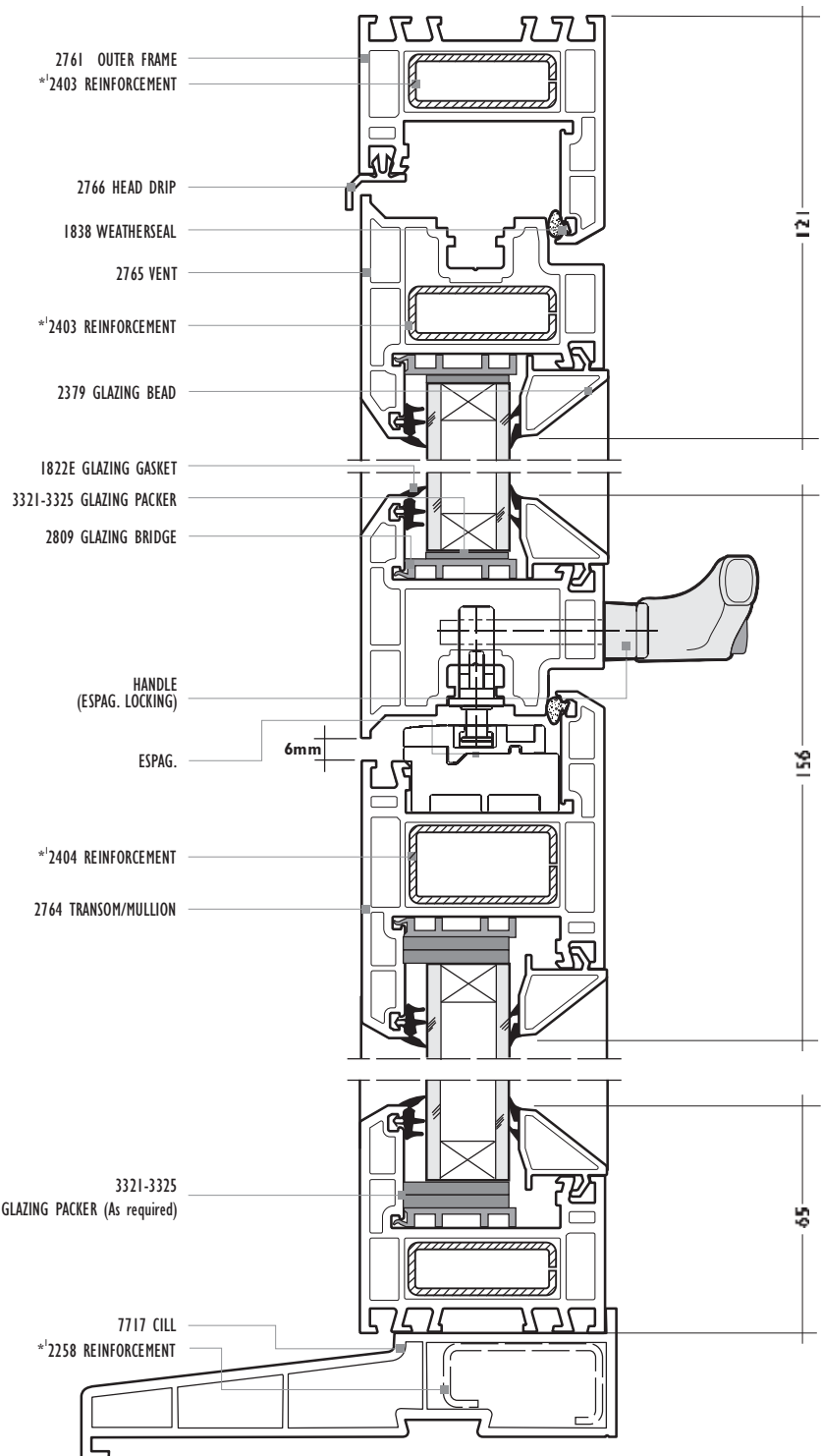

## Window Styles

Miscellaneous Applications



# Miscellaneous Applications

## Concrete Cill Infill (1715) & Box Sash Adaptor (1977)

CATEGORY	DESCRIPTION	STYLE
PRODUCT	ASSEMBLIES	MISCELLANEOUS APPLICATIONS

### MISCELLANEOUS APPLICATIONS - CONCRETE CILL INFILL (1715)

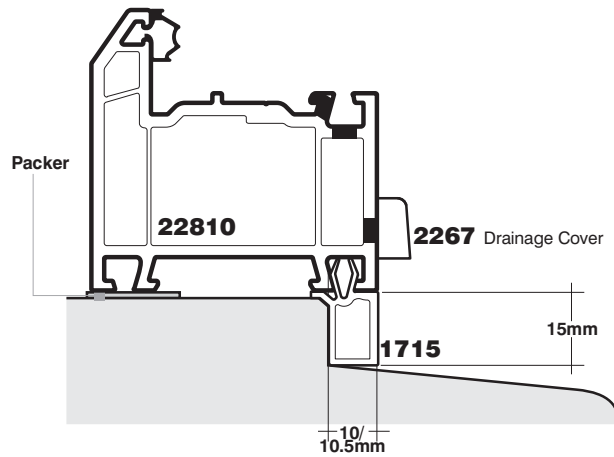
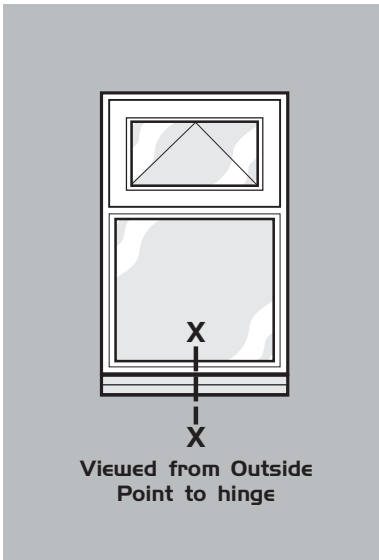

### SPECIAL APPLICATIONS - BOX SASH ADAPTOR (1977)

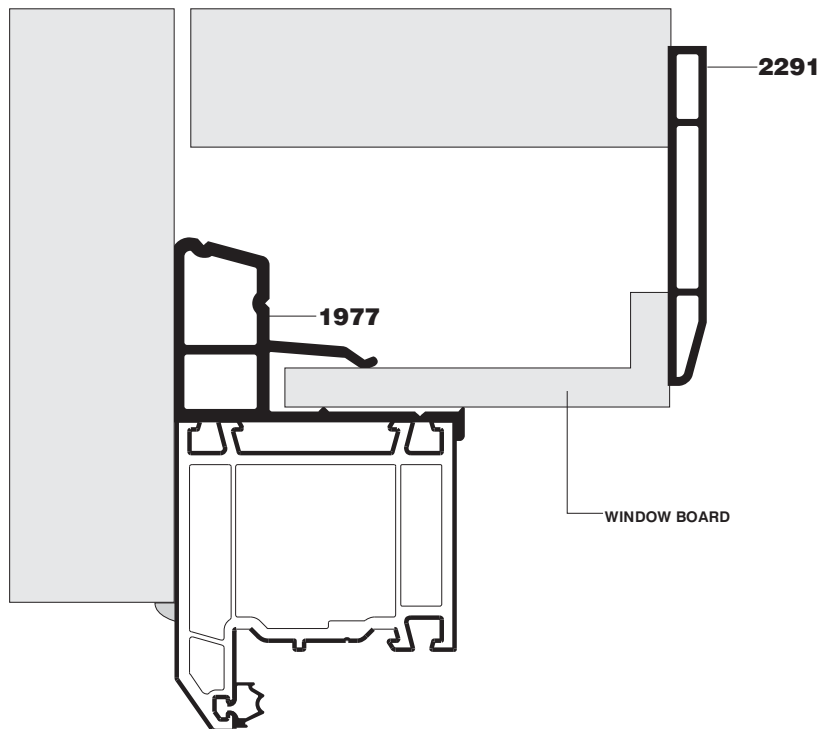
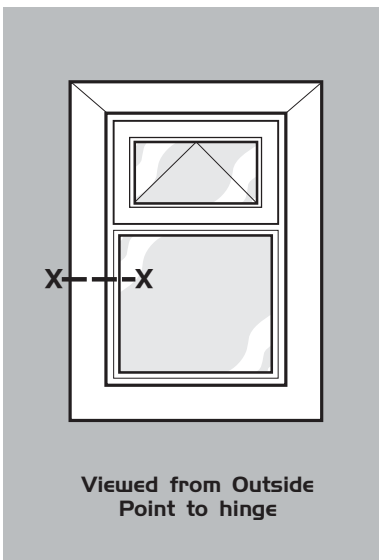

# 1 Product



## Door Styles

Residential Door

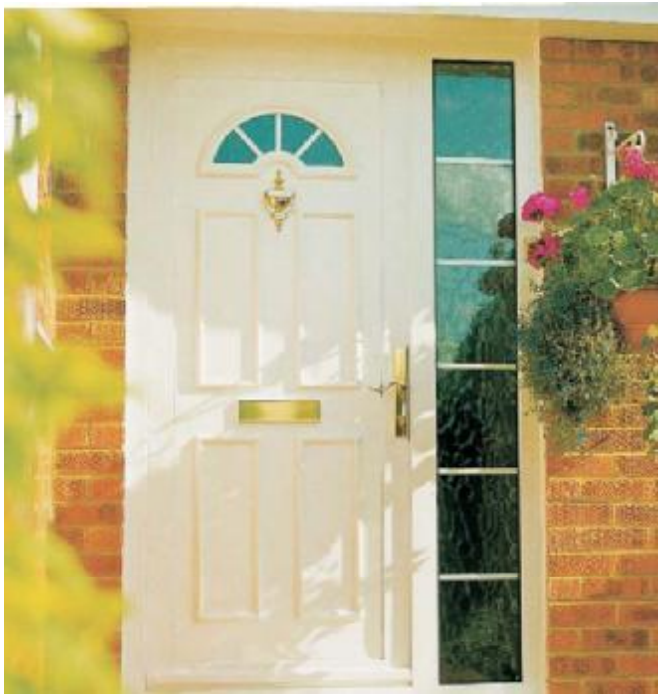

# Fully Chamfered 60mm Single Door (Open-In) Internal Glazing

CATEGORY	DESCRIPTION	STYLE
PRODUCT	ASSEMBLIES	RESIDENTIAL DOOR

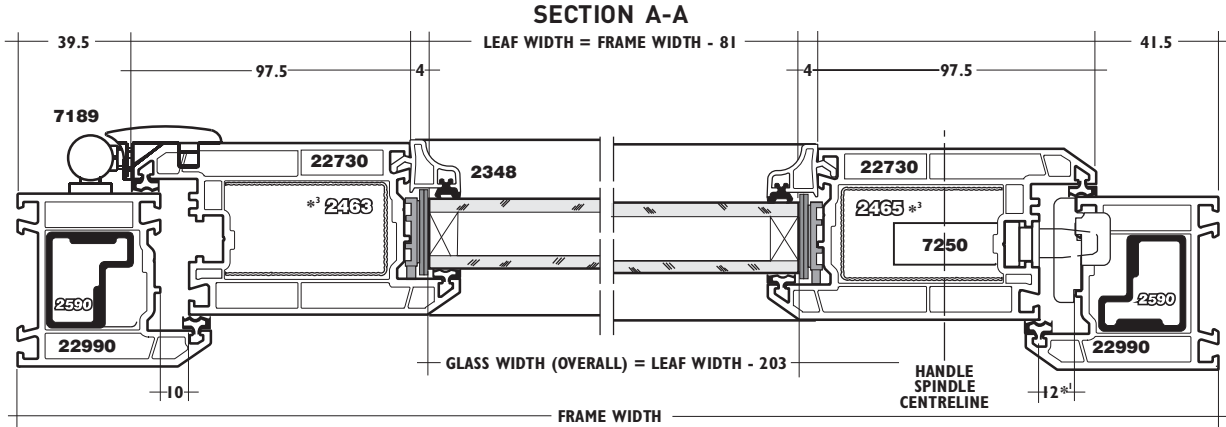

## Fully Chamfered 60mm

- Single Door - Open In
- Fully Chamfered
- 24mm Double Glazing
- Internally Glazed
- Bubblex Seals

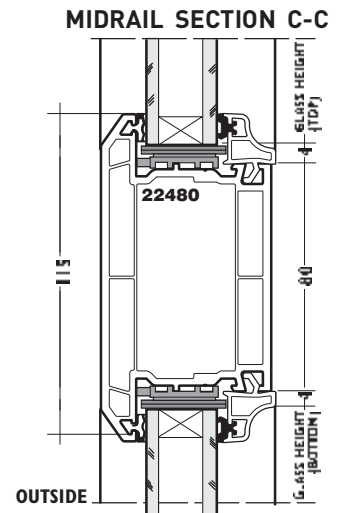
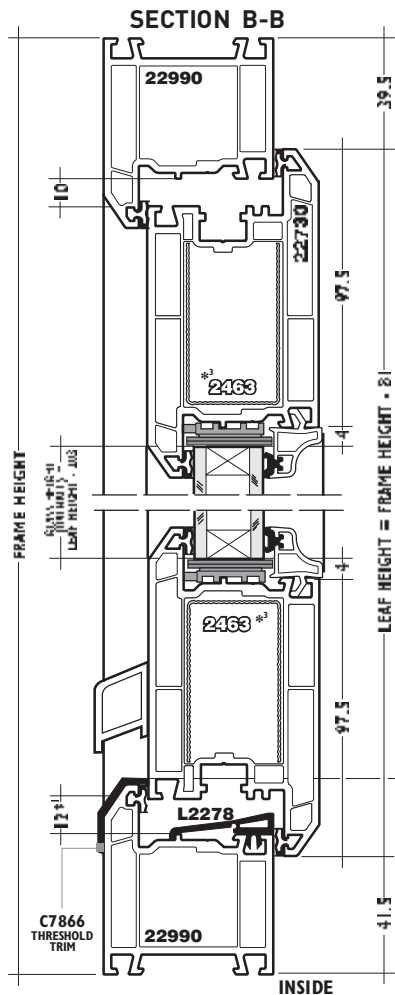
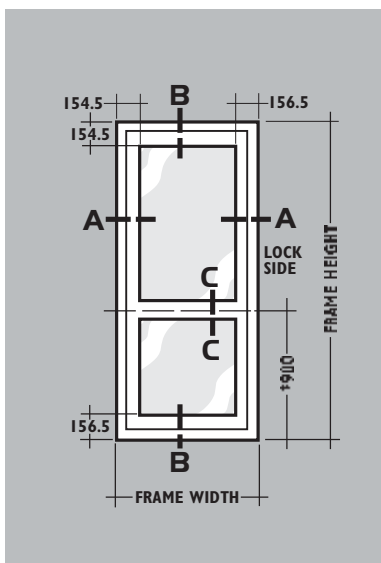

### THRESHOLD OPTIONS\*2

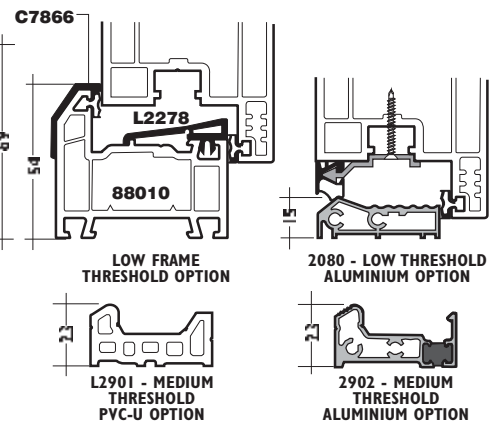

- \*Note: Denotes midrail centreline recommended dimension (unless otherwise required).
- \*1Note: Leaf/Frame spacing - maintain 12mm on lockside and at sill.
- \*2Note: LOW THRESHOLDS - THESE WILL NOT PROVIDE THE SAME WEATHERING PERFORMANCE AS FULL FRAME THRESHOLDS.
- \*3Note: Standard Reinforcing shown.

# Fully Chamfered 60mm Double Door (Open-Out) Internal Glazing

CATEGORY	DESCRIPTION	STYLE
PRODUCT	ASSEMBLIES	RESIDENTIAL DOOR

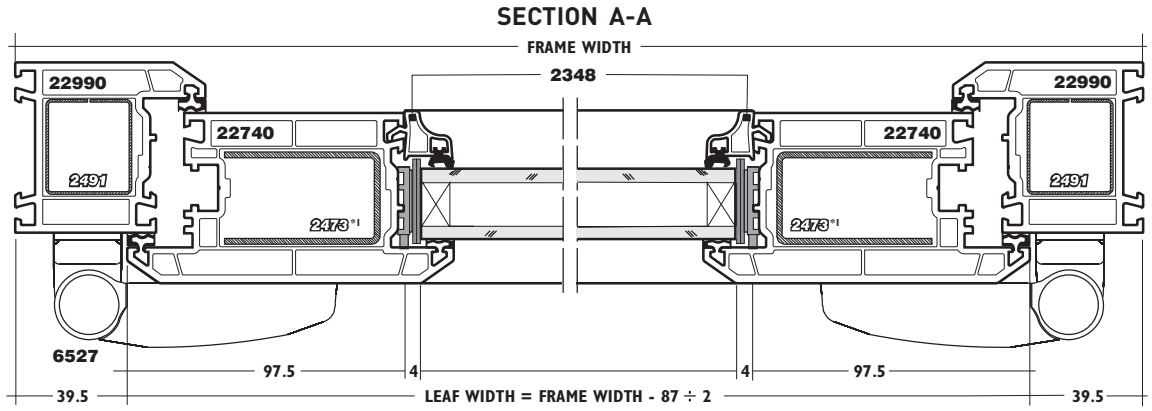

## Fully Chamfered 60mm

- Double Door - Open Out
- Fully Chamfered
- 24mm Double Glazing
- Internally Glazed Scotia Bead
- Bubblex Seals

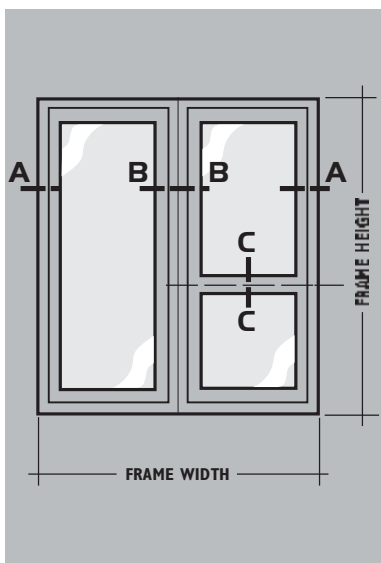

## SECTION B-B

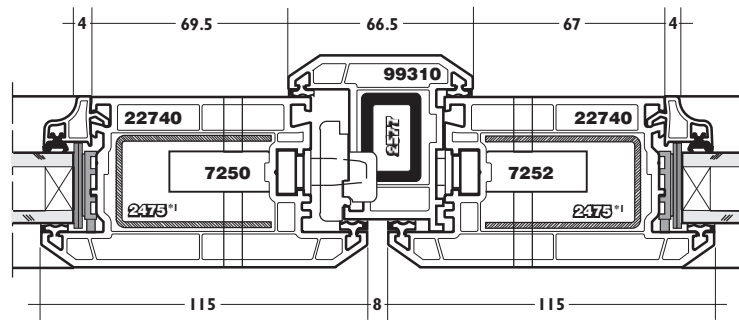

## MIDRAIL SECTION C-C

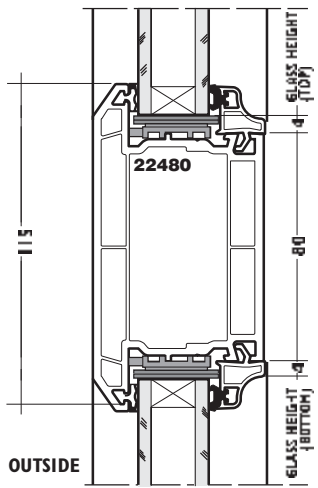

## THRESHOLD OPTIONS\*

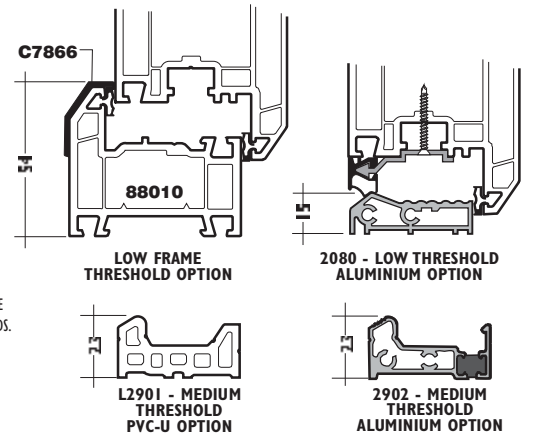

\* Note: LOW THRESHOLDS - THESE WILL NOT PROVIDE THE SAME WEATHERING PERFORMANCE AS FULL FRAME THRESHOLDS.  
 \*Note: PAS 023- PAS 024 High Security reinforcing shown.

# Fully Chamfered 60mm Slim Leaf Single Door (Open-In) Internal Glazing

CATEGORY	DESCRIPTION	STYLE
PRODUCT	ASSEMBLIES	RESIDENTIAL DOOR

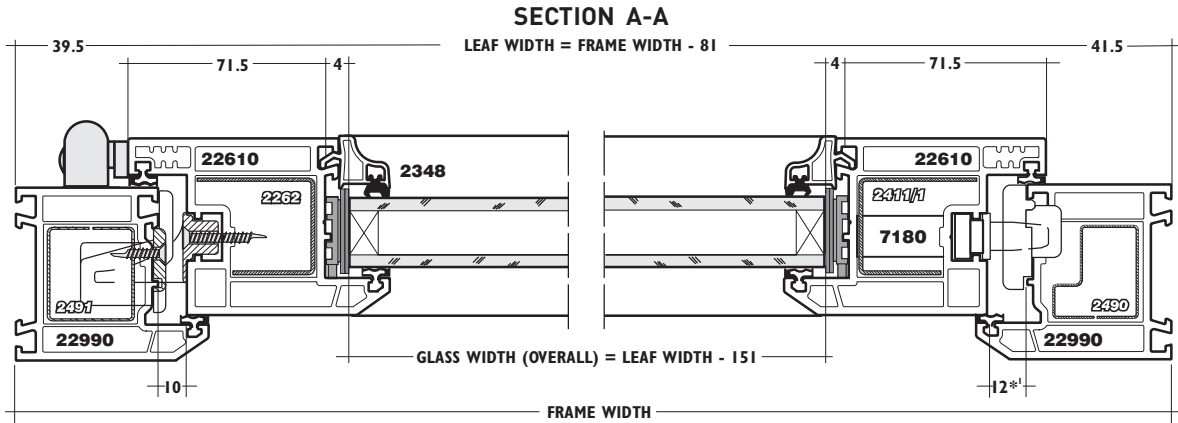

## Fully Chamfered 60mm

- Slim Door - Open In
- Fully Chamfered
- 24mm Double Glazing
- Internally Glazed Scotia Bead
- Bubblex Seals

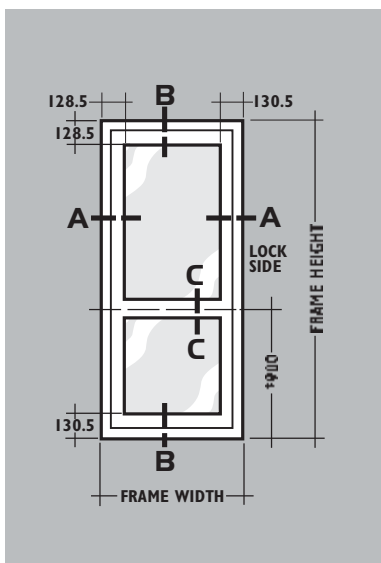

## SECTION B-B

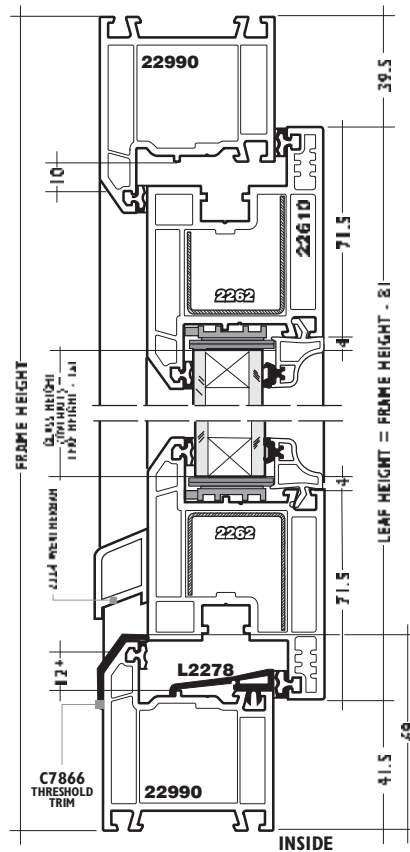

## MIDRAIL SECTION C-C

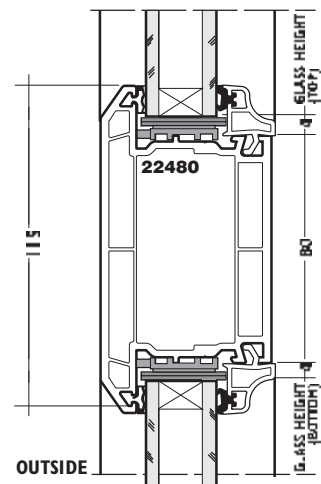

## THRESHOLD OPTIONS\*2

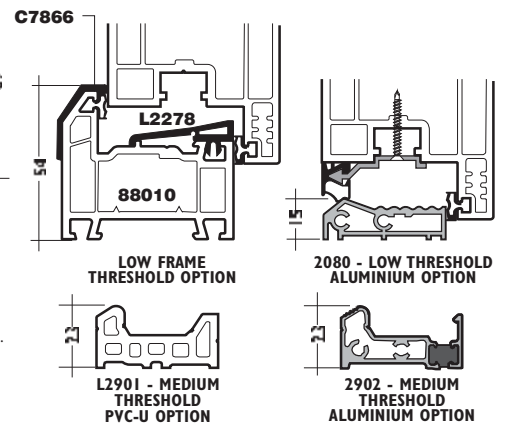

- \*Note: Denotes midrail centreline recommended dimension (unless otherwise required).
- \*1Note: Leaf/frame spacing - maintain 12mm on lockside and at sill.
- \*2Note: LOW THRESHOLDS - THESE WILL NOT PROVIDE THE SAME WEATHERING PERFORMANCE AS FULL FRAME THRESHOLDS.



# Fully Chamfered 60mm Slim Leaf French Door (Open-Out) External Glazing

CATEGORY	DESCRIPTION	STYLE
PRODUCT	ASSEMBLIES	RESIDENTIAL DOOR

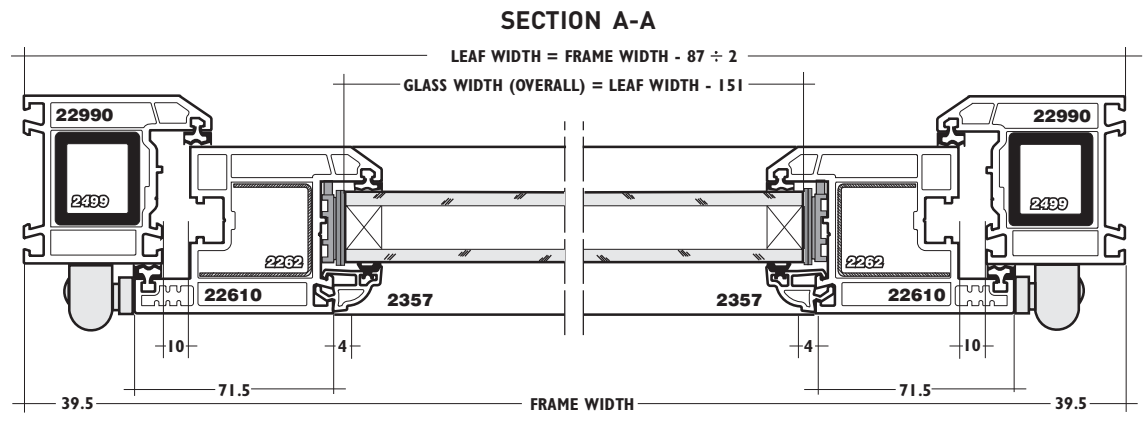

## Fully Chamfered 60mm

- Slim French Door Open Out
- Fully Chamfered
- 24mm Double Glazing
- Externally Glazed Ovolo Bead
- Bubblex Seals

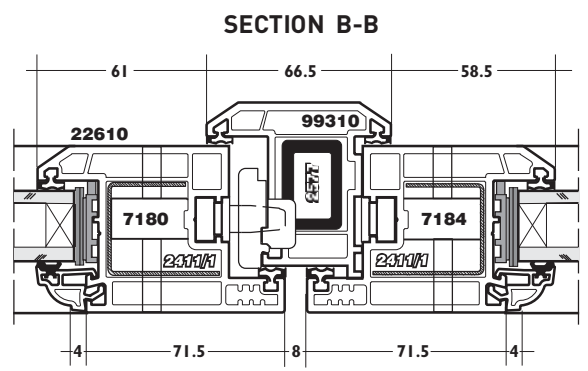
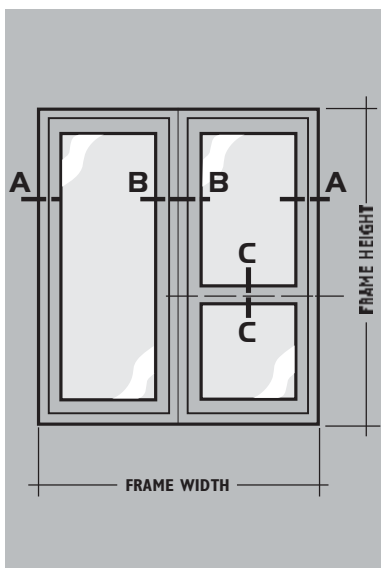

### MIDRAIL SECTION C-C

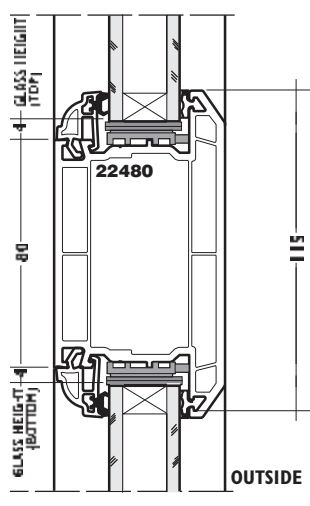

### THRESHOLD OPTIONS\*2

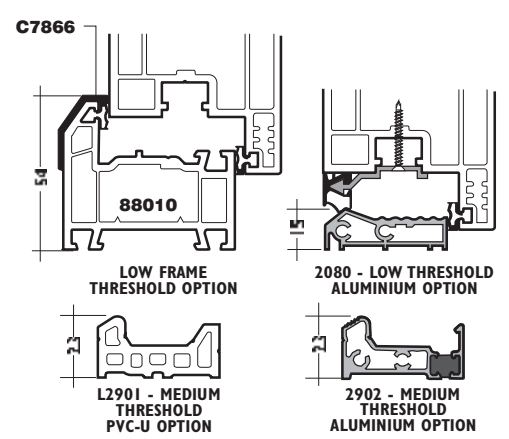

\* Note: LOW THRESHOLDS - THESE WILL NOT PROVIDE THE SAME WEATHERING PERFORMANCE AS FULL FRAME THRESHOLDS.

# Fully Integrated 70mm Single Door (Open-In) Internal Glazing

CATEGORY	DESCRIPTION	STYLE
PRODUCT	ASSEMBLIES	RESIDENTIAL DOOR

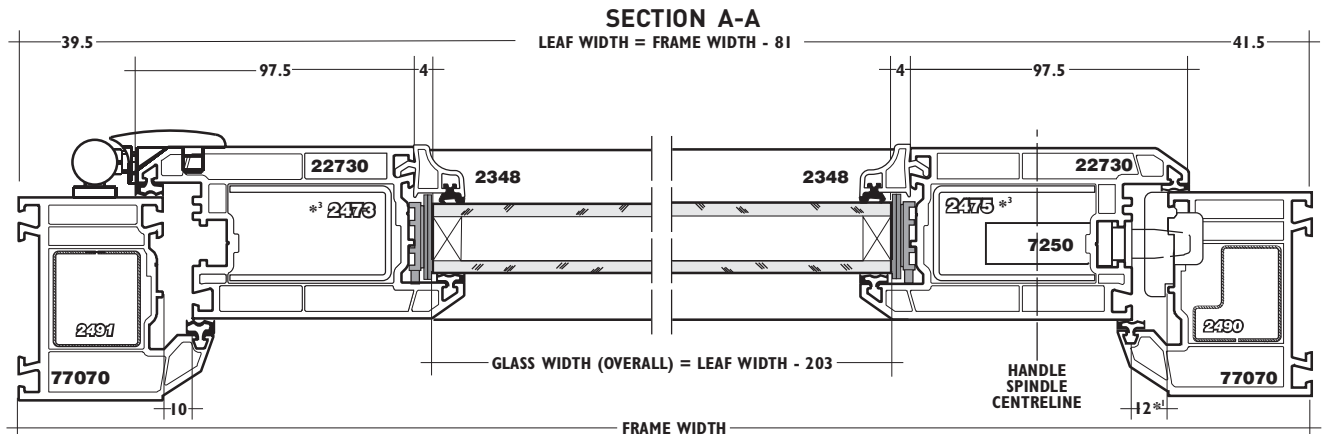

## Fully Integrated 70mm

- Single Door - Open In
- Fully Integrated
- 24mm Double Glazing
- Internally Glazed
- Bubblem Seals

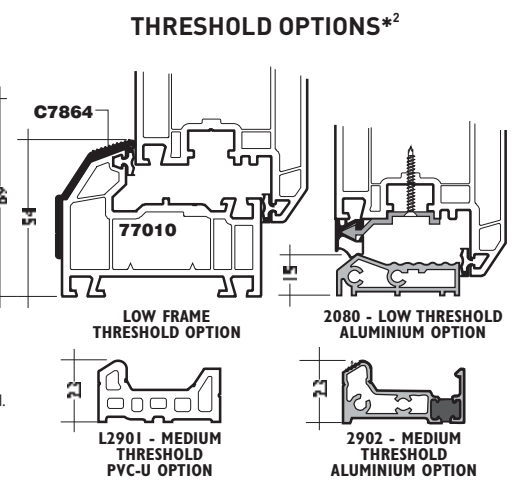
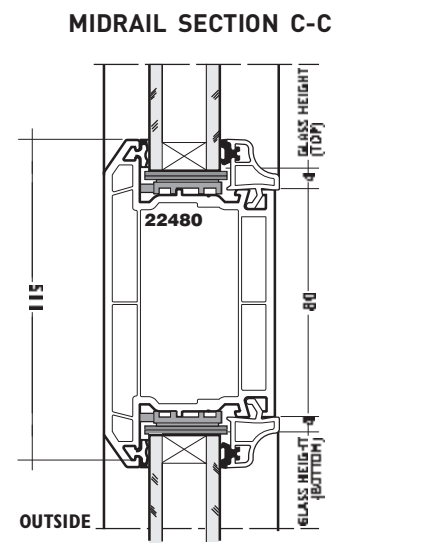
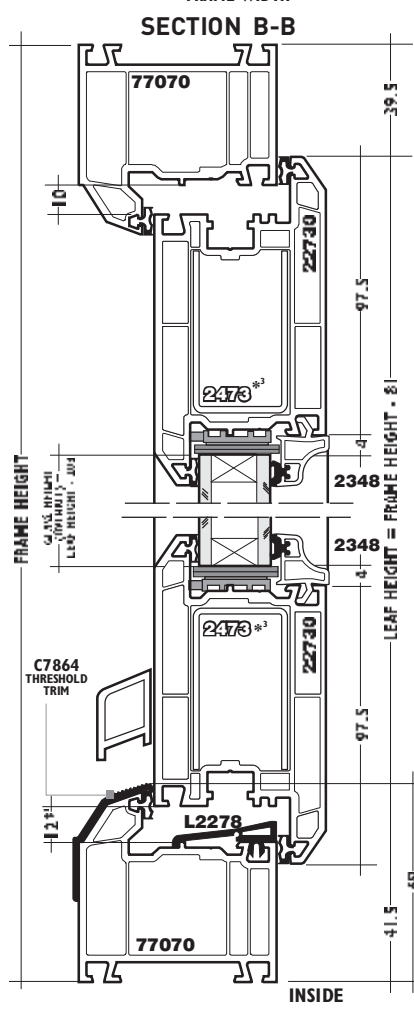
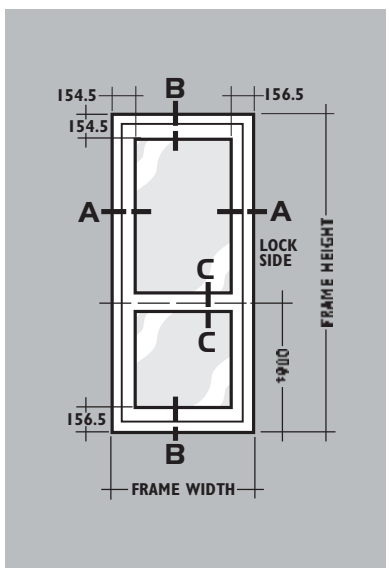

- \*Note: Denotes midrail centreline recommended dimension (unless otherwise required).
- \*Note: Leaf/Frame spacing - maintain 12mm on lockside and at sill.
- \*Note: LOW THRESHOLDS - THESE WILL NOT PROVIDE THE SAME WEATHERING PERFORMANCE AS FULL FRAME THRESHOLDS.
- \*Note: PAS 023- PAS 024 High Security reinforcing shown

# Fully Integrated 70mm Double Door (Open-Out) Internal Glazing

CATEGORY	DESCRIPTION	STYLE
PRODUCT	ASSEMBLIES	RESIDENTIAL DOOR

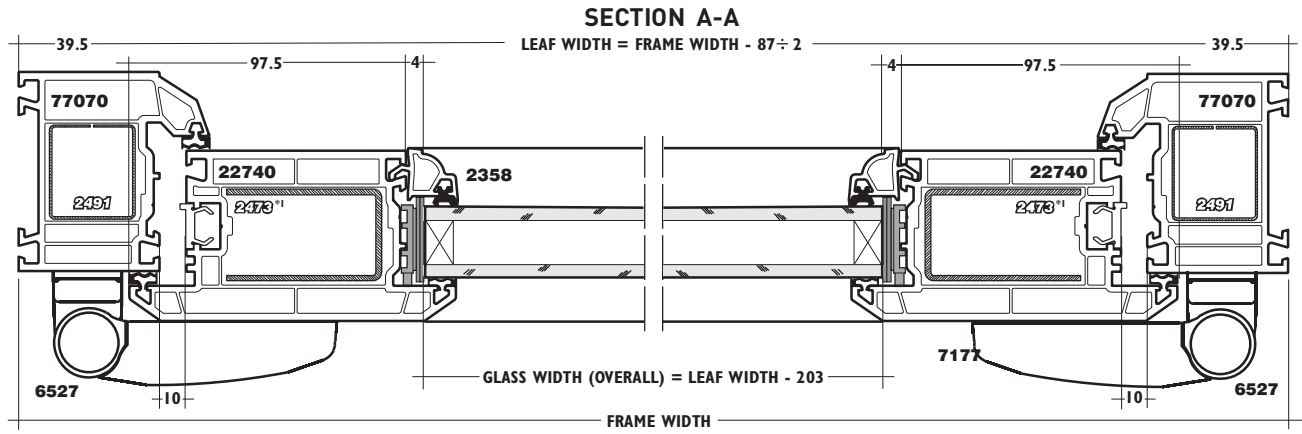

Fully Integrated 70mm

- Double Door - Open Out
- Fully Integrated
- 24mm Double Glazing
- Internally Glazed
- Bubblex Seals

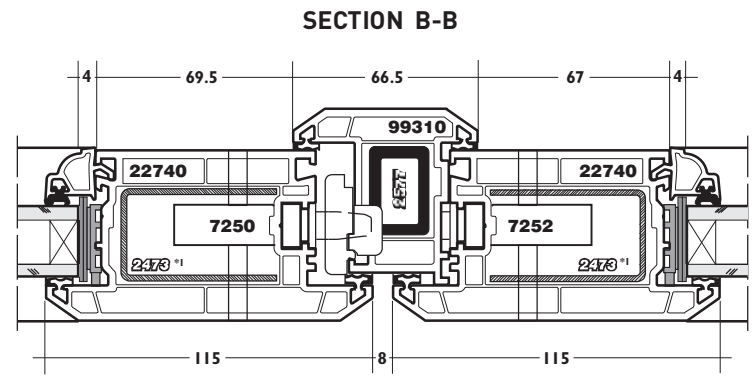
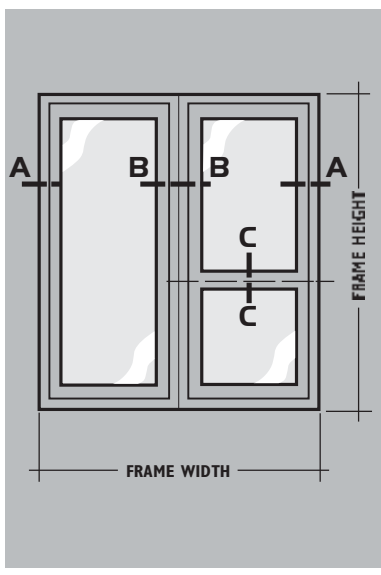

**MIDRAIL SECTION C-C**

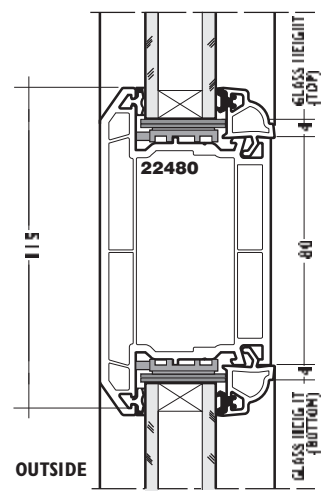

**THRESHOLD OPTIONS\***

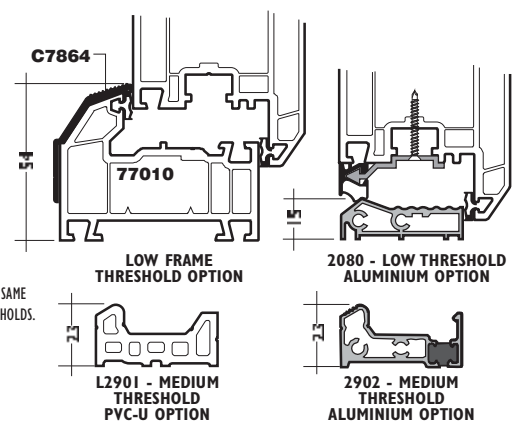

\*Note: LOW THRESHOLDS - THESE WILL NOT PROVIDE THE SAME WEATHERING PERFORMANCE AS FULL FRAME THRESHOLDS.  
\*Note: PAS 023- PAS 024 High Security reinforcing shown

All dimensions are nominal. DO NOT SCALE  
TD-02-0037-1-0\06-08

All information in this publication is provided for guidance only and is given in good faith. As it is company policy to continually improve products, methods and materials, changes of specification may be made from time to time without prior notice. This statement does not affect your statutory rights. ©PROFILE22

# Fully Integrated 70mm Single Slim Door (Open-In) Internal Glazing

CATEGORY	DESCRIPTION	STYLE
PRODUCT	ASSEMBLIES	RESIDENTIAL DOOR

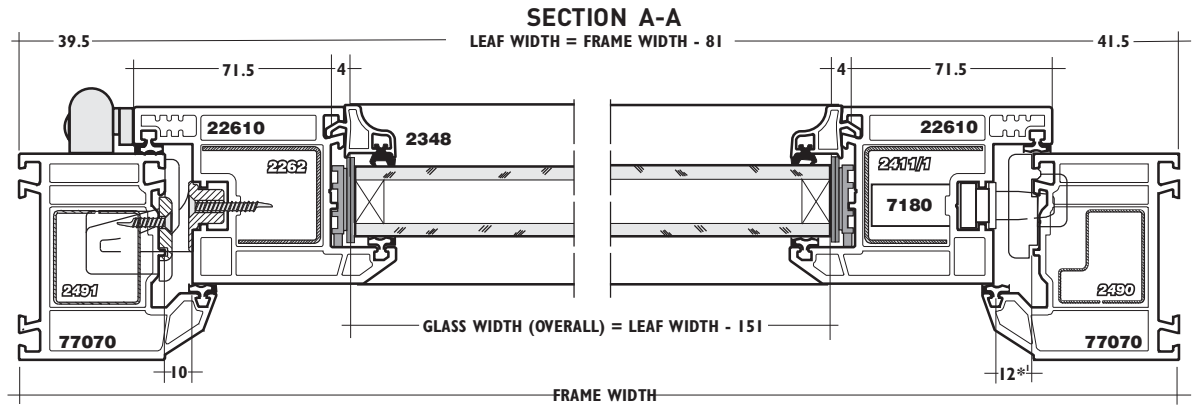

## Fully Integrated 70mm

- Slim Door - Open In
- Fully Integrated
- 24mm Double Glazing
- Internally Glazed Scotia Bead
- Bubblex Seals

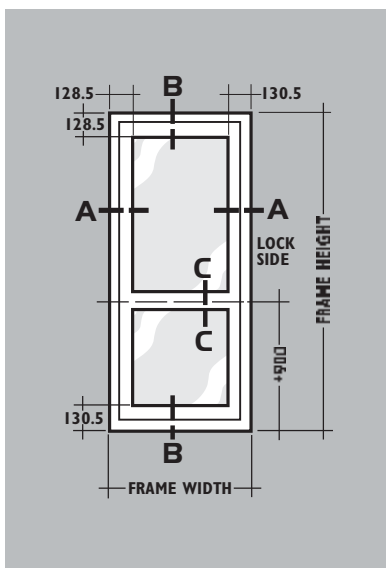

## SECTION B-B

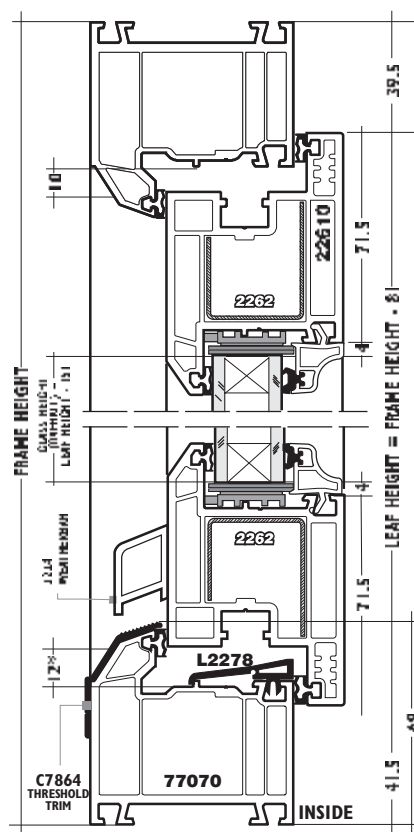

## MIDRAIL SECTION C-C

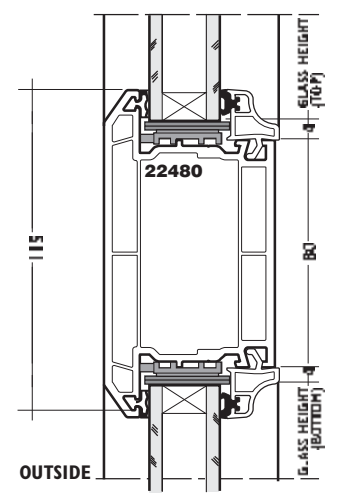

## THRESHOLD OPTIONS\*2

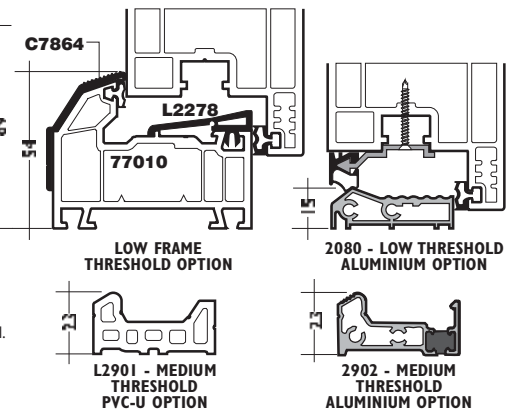

- \*Note: Denotes midrail centreline recommended dimension (unless otherwise required).
- \*Note: Leaf/frame spacing - maintain 12mm on lockside and at sill.
- \*Note: LOW THRESHOLDS - THESE WILL NOT PROVIDE THE SAME WEATHERING PERFORMANCE AS FULL FRAME THRESHOLDS.

# Fully Integrated 70mm Double French Door (Open-Out) External Glazing

CATEGORY	DESCRIPTION	STYLE
PRODUCT	ASSEMBLIES	RESIDENTIAL DOOR

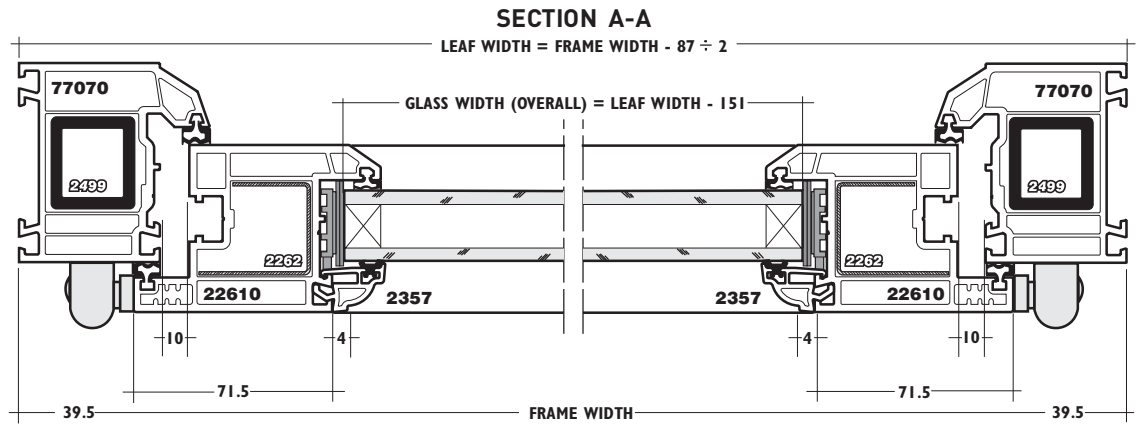

Fully Integrated 70mm

- Slim French Door Open Out
- Fully Integrated
- 28mm Double Glazing
- Externally Glazed Ovolo Bead
- Bubblex Seals

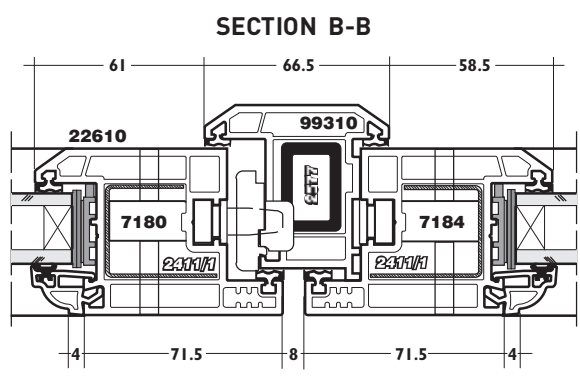
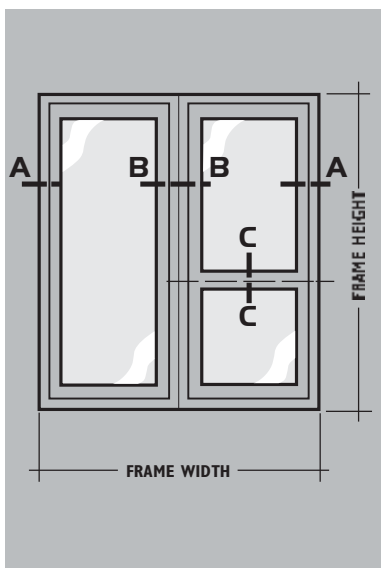

**MIDRAIL SECTION C-C**

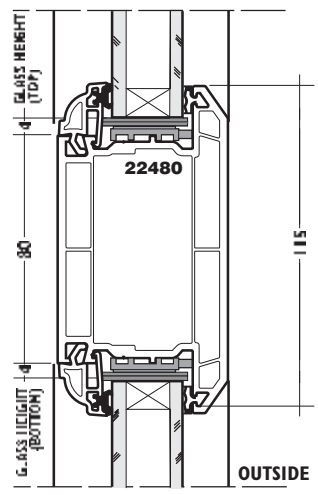

**THRESHOLD OPTIONS\***

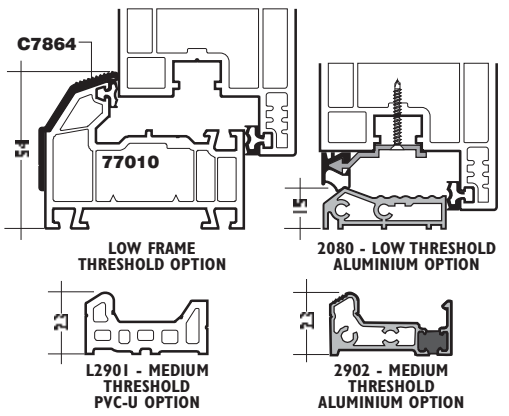

\*Note: LOW THRESHOLDS - THESE WILL NOT PROVIDE THE SAME WEATHERING PERFORMANCE AS FULL FRAME THRESHOLDS.

All dimensions are nominal. DO NOT SCALE  
TD-02-0041-1-0\06-08

All information in this publication is provided for guidance only and is given in good faith. As it is company policy to continually improve products, methods and materials, changes of specification may be made from time to time without prior notice. This statement does not affect your statutory rights. ©PROFILE22

# Fully Bevelled 70mm Single Door (Open-In) Internal Glazing

CATEGORY	DESCRIPTION	STYLE
PRODUCT	ASSEMBLIES	RESIDENTIAL DOOR

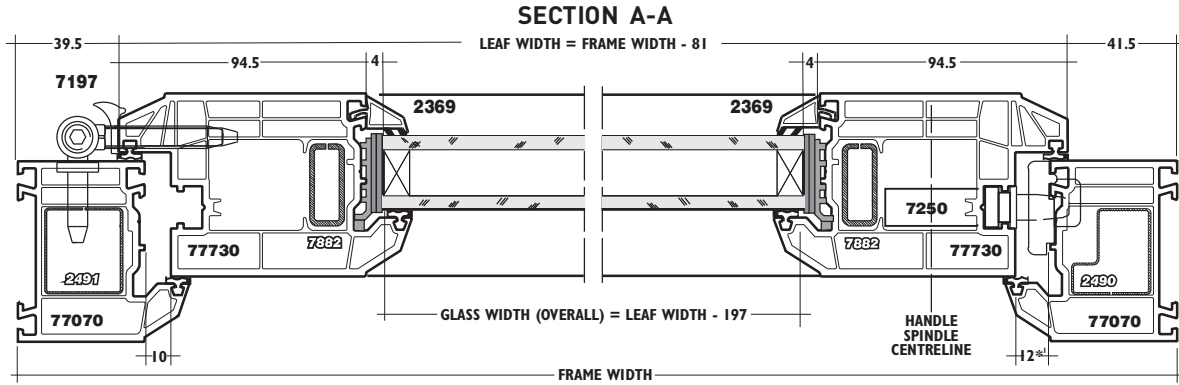

## Fully Bevelled 70mm

- Single Door - Open In
- Fully Bevelled
- 28mm Double Glazing
- Internally Glazed Bevelled Feature Bead
- Bubblex Seals

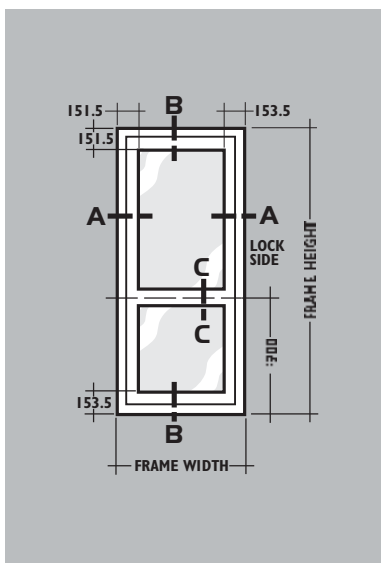

## SECTION B-B

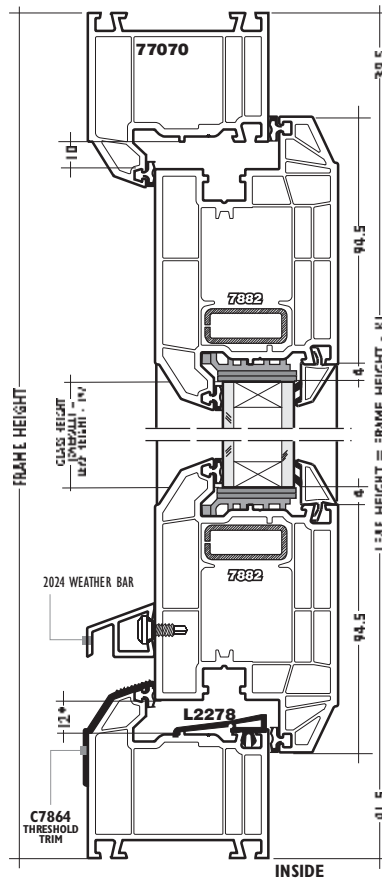

## MIDRAIL SECTION C-C

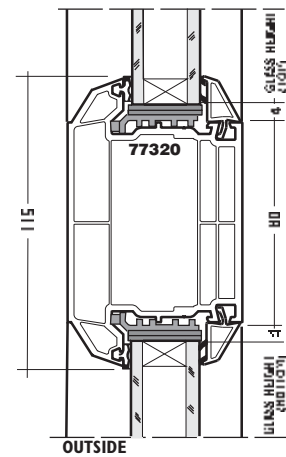

## THRESHOLD OPTIONS\*2

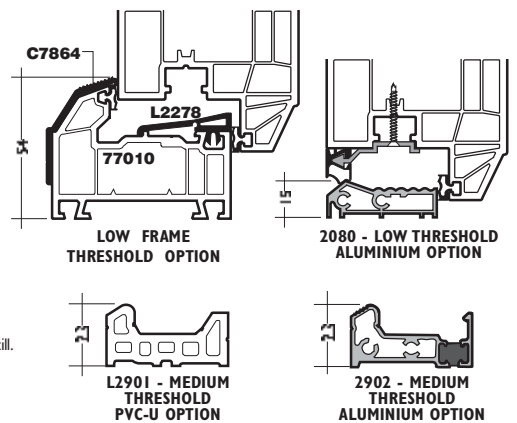

- \*Note: Denotes midrail centreline recommended dimension (unless otherwise required).
- \*Note: Leaf/Frame spacing - maintain 12mm on lockside and at sill.
- \*Note: LOW THRESHOLDS - THESE WILL NOT PROVIDE THE SAME WEATHERING PERFORMANCE AS FULL FRAME THRESHOLDS.

# Fully Bevelled 70mm Double Door (Open-Out) Internal Glazing

CATEGORY	DESCRIPTION	STYLE
PRODUCT	ASSEMBLIES	RESIDENTIAL DOOR

### SECTION A-A

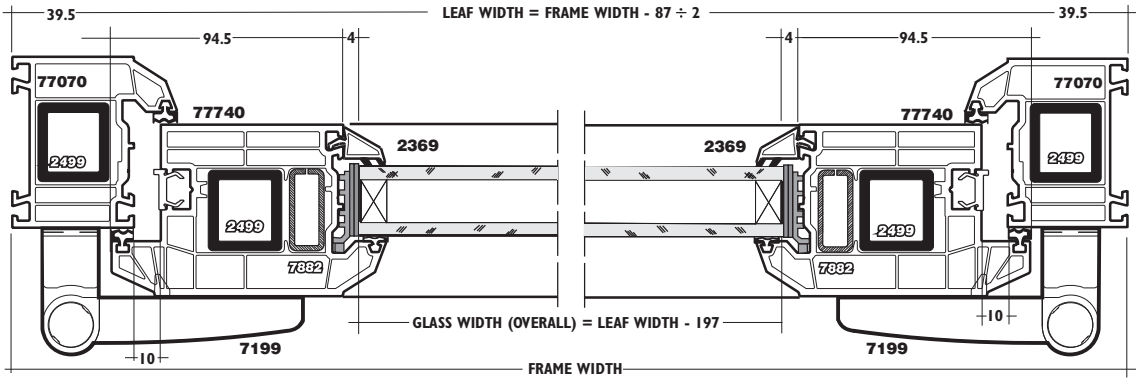

### Fully Bevelled 70mm

- Double Door - Open Out
- Fully Bevelled
- 28mm Double Glazing
- Internally Glazed Bevelled Feature Bead
- Bubblex Seals

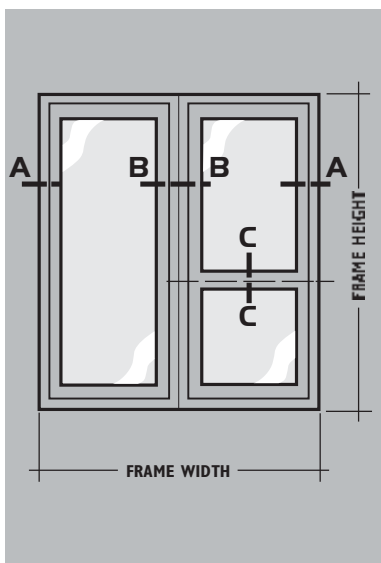

### SECTION B-B

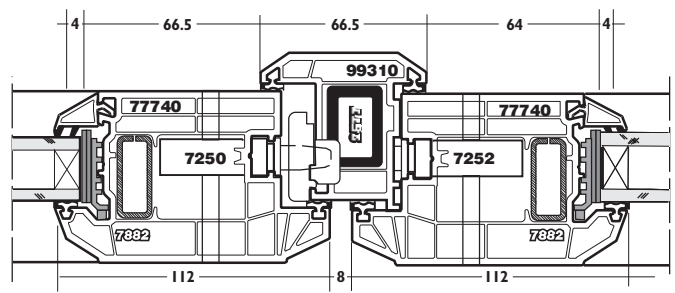

### MIDRAIL SECTION C-C

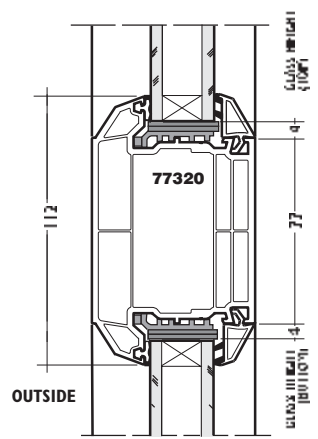

### THRESHOLD OPTIONS\*

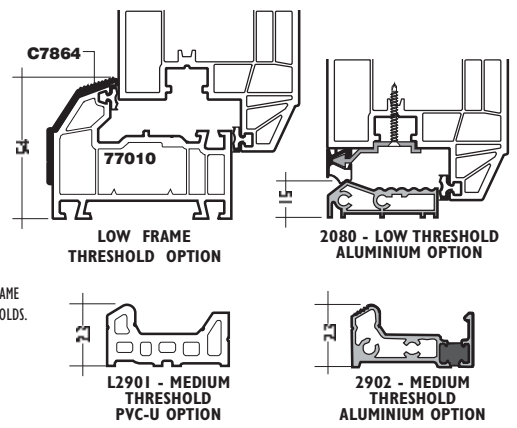

\*Note: LOW THRESHOLDS - THESE WILL NOT PROVIDE THE SAME WEATHERING PERFORMANCE AS FULL FRAME THRESHOLDS.

All dimensions are nominal. DO NOT SCALE  
TD-02-0038-1-0\06-08

All information in this publication is provided for guidance only and is given in good faith. As it is company policy to continually improve products, methods and materials, changes of specification may be made from time to time without prior notice. This statement does not affect your statutory rights. ©PROFILE22

# Fully Sculptured 70mm Single Door (Open-In) Internal Glazing

CATEGORY	DESCRIPTION	STYLE
PRODUCT	ASSEMBLIES	RESIDENTIAL DOOR

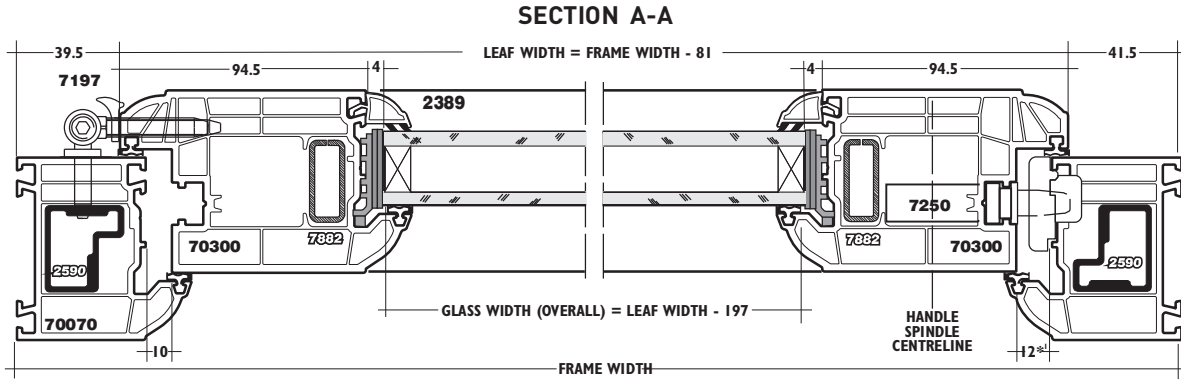

**Fully Sculptured 70mm**

- Single Door - Open In
- Fully Sculptured
- 28mm Double Glazing
- Internally Glazed Sculptured Feature Bead
- Bubblex Seals

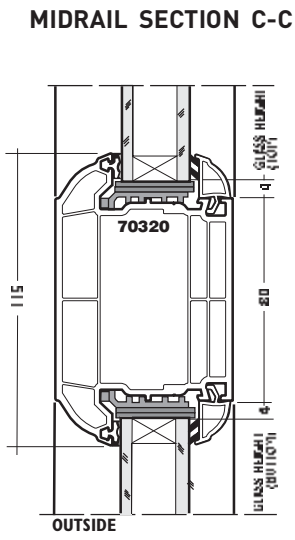
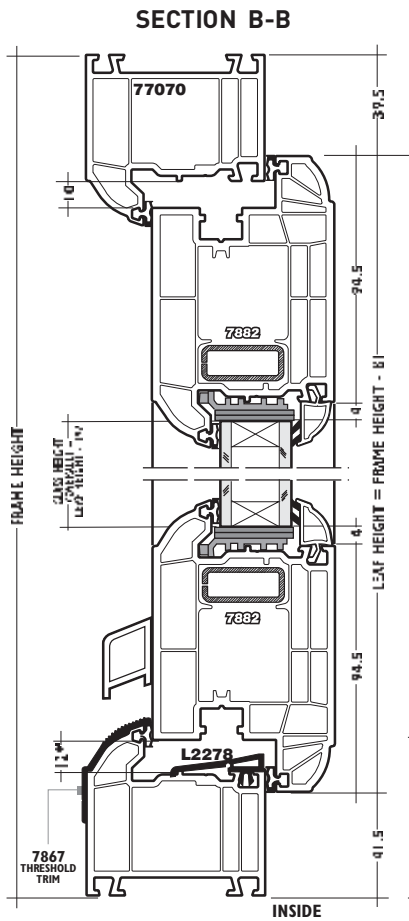
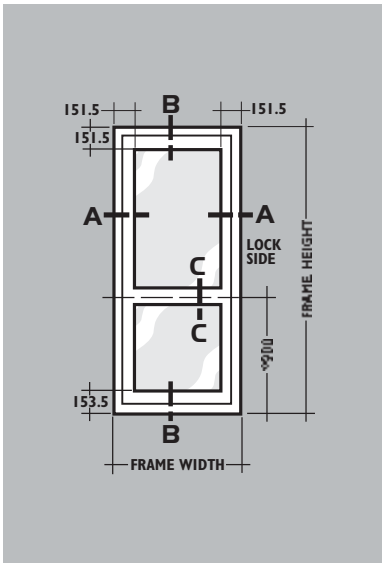

**THRESHOLD OPTIONS\*2**

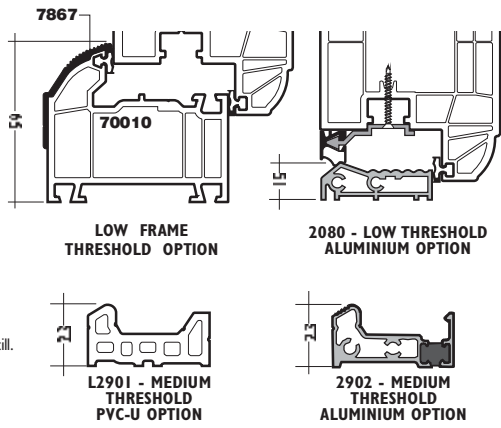

- \*Note: Denotes midrail centreline recommended dimension (unless otherwise required).
- \*Note: Leaf/Frame spacing - maintain 12mm on lockside and at sill.
- \*Note: LOW THRESHOLDS - THESE WILL NOT PROVIDE THE SAME WEATHERING PERFORMANCE AS FULL FRAME THRESHOLDS.

All dimensions are nominal. DO NOT SCALE  
TD-02-0036-1-0\06-08

All information in this publication is provided for guidance only and is given in good faith. As it is company policy to continually improve products, methods and materials, changes of specification may be made from time to time without prior notice. This statement does not affect your statutory rights. ©PROFILE22



# Fully Sculptured 70mm Double Door (Open-Out) Internal Glazing

CATEGORY	DESCRIPTION	STYLE
PRODUCT	ASSEMBLIES	RESIDENTIAL DOOR

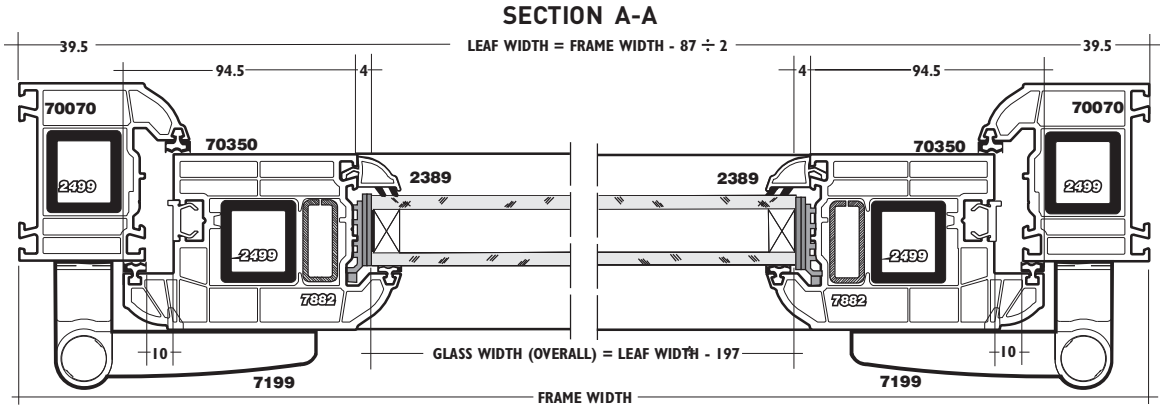

## Fully Sculptured 70mm

- Double Door - Open Out
- Fully Sculptured
- 28mm Double Glazing
- Internally Glazed Sculptured Feature Bead
- Bubblex Seals

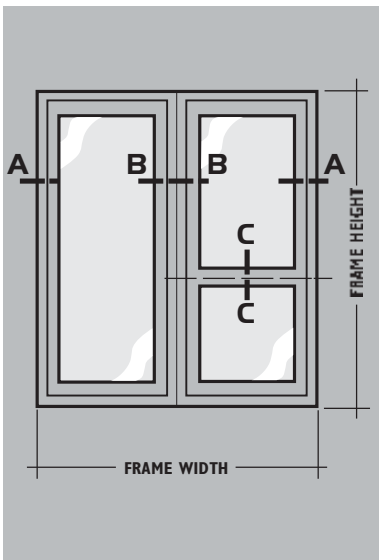

## SECTION B-B

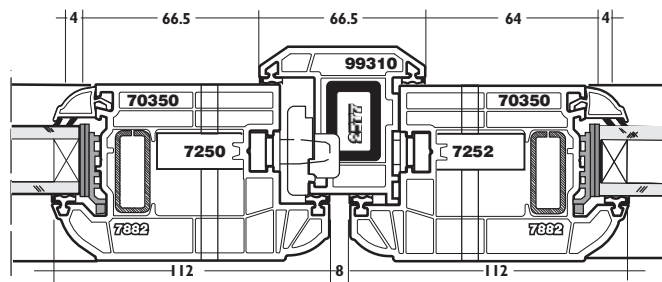

## MIDRAIL SECTION C-C

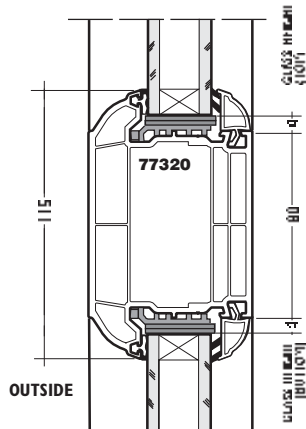

## THRESHOLD OPTIONS\*

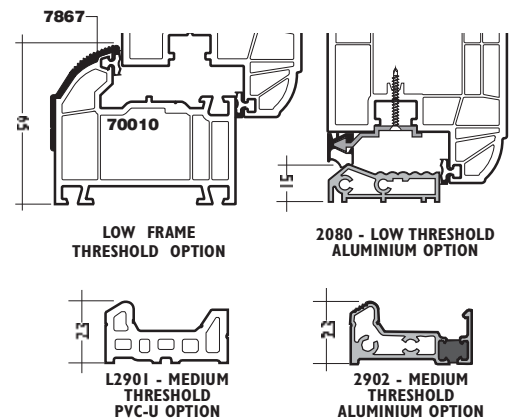

**\*Note:** LOW THRESHOLDS - THESE WILL NOT PROVIDE THE SAME WEATHERING PERFORMANCE AS FULL FRAME THRESHOLDS.

# Doors with Side Screens

## Coupled Side Screen

CATEGORY	DESCRIPTION	STYLE
PRODUCT	ASSEMBLIES	DOORS WITH SIDE SCREENS

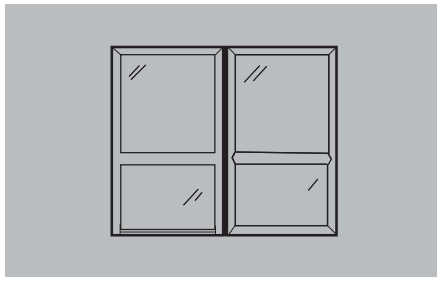

**Notes:** Reinforcements shown in brackets.  
 Glazing packing as per single door assemblies.  
 Hardware not shown for clarity, see other assemblies for details.

Fully Chamfered 60mm

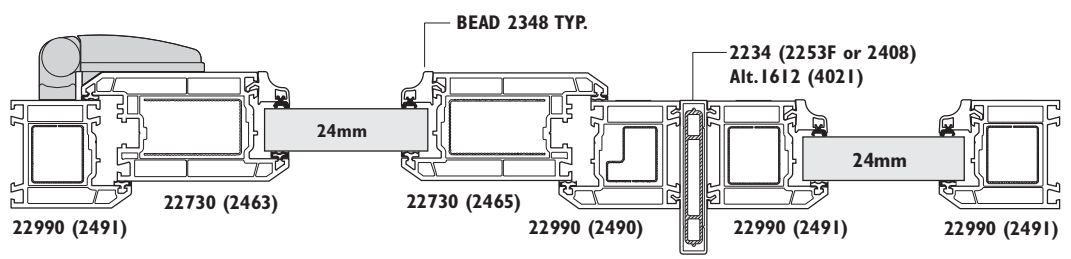

Fully Integrated 70mm

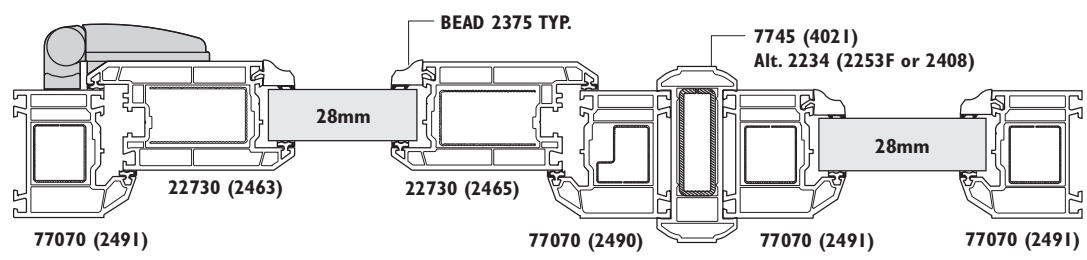

Fully Bevelled 70mm

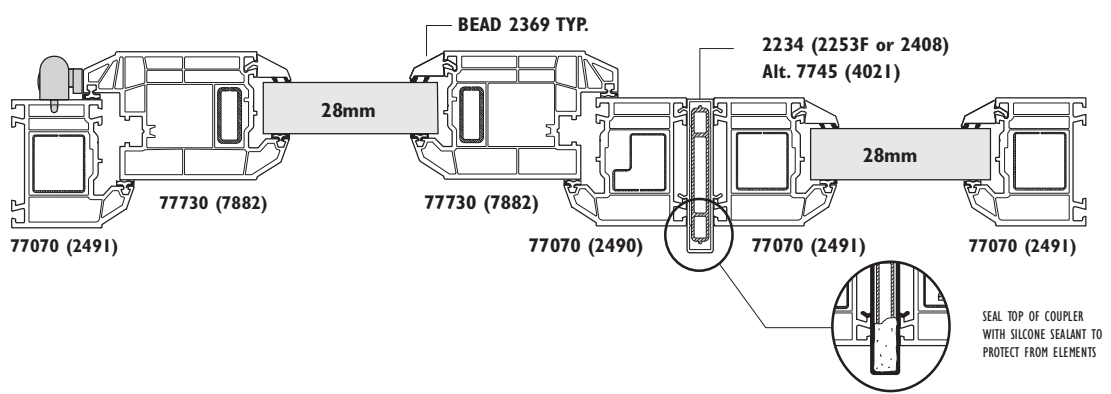

Fully Sculptured 70mm

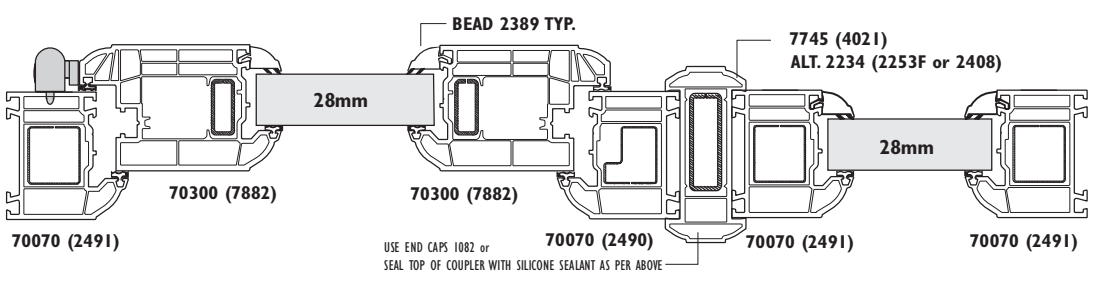

# Doors with Side Screens Common Mullion Frame

CATEGORY	DESCRIPTION	STYLE
PRODUCT	ASSEMBLIES	DOORS WITH SIDE SCREENS

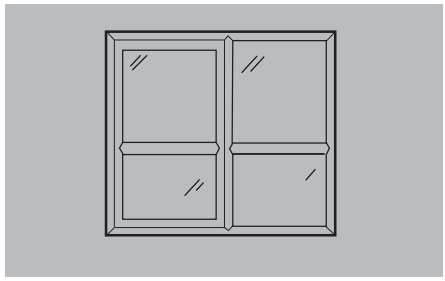

**Notes:** Reinforcements shown in brackets.  
Glazing packing as per single door assemblies.  
Hardware not shown for clarity, see other assemblies for details.

Fully Chamfered 60mm

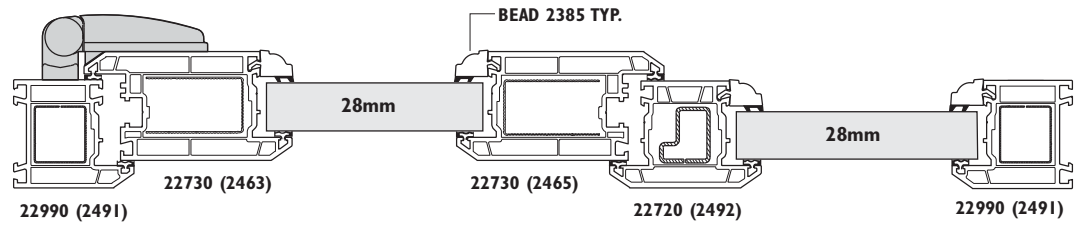

Fully Integrated 70mm

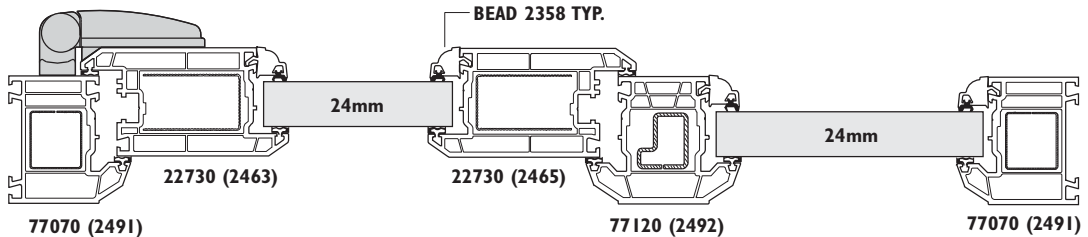

Fully Bevelled 70mm

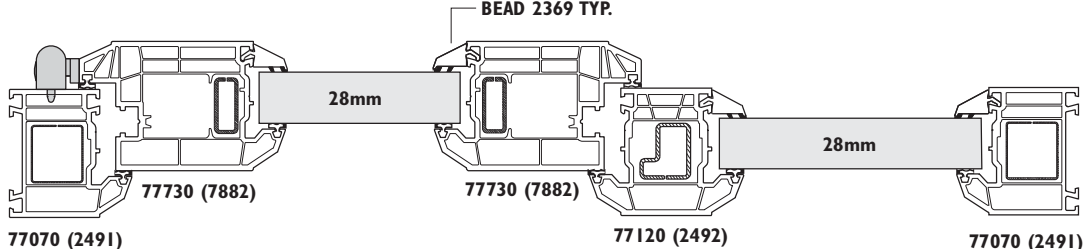

Fully Sculptured 70mm

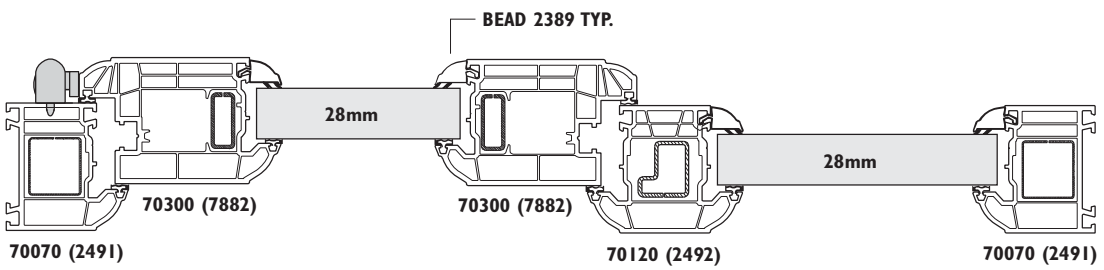

# 1 Product



## Door Styles

Composite Door



# 60mm Composite Door Frame System

## Frame System

CATEGORY	DESCRIPTION	STYLE
PRODUCT	ASSEMBLIES	COMPOSITE DOOR

SECTION A-A

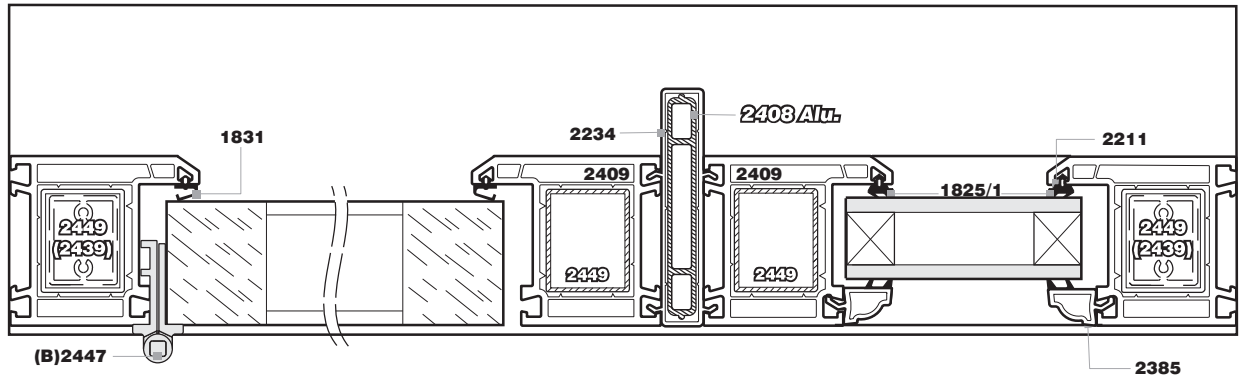

### Composite Door 60mm

- Composite Door
- Fully Chamfered
- 28mm Double Glazing
- Composite Panelling
- Internally Glazed

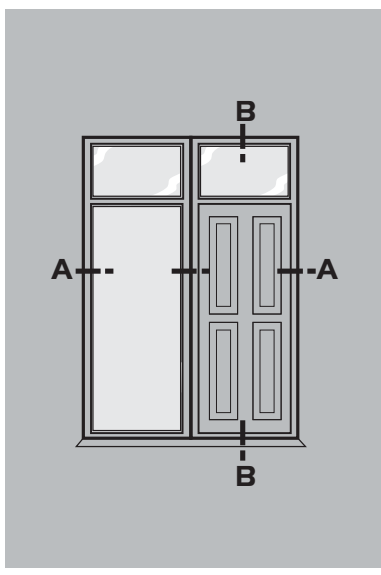

SECTION B-B

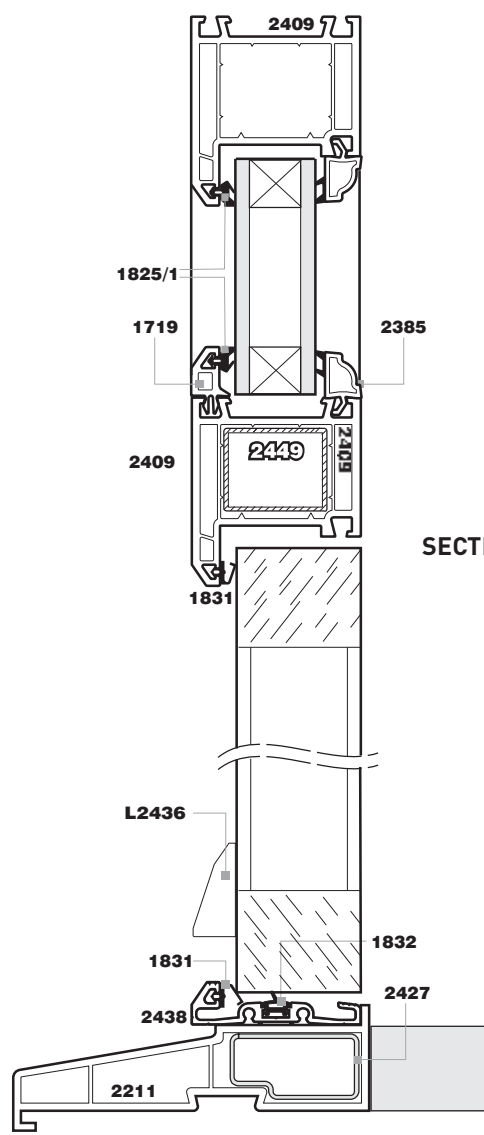

All dimensions are nominal. DO NOT SCALE  
TD-02-0044-1-0\06-08



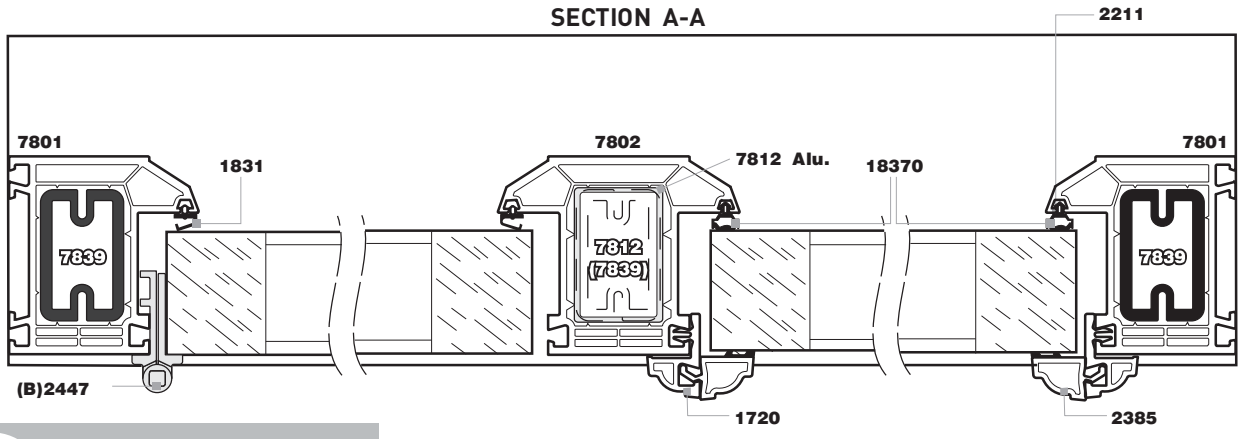

All information in this publication is provided for guidance only and is given in good faith. As it is company policy to continually improve products, methods and materials, changes of specification may be made from time to time without prior notice. This statement does not affect your statutory rights. ©PROFILE22

# 70mm Composite Door Frame System With Slab Side Panel Arrangement

CATEGORY	DESCRIPTION	STYLE
PRODUCT	ASSEMBLIES	COMPOSITE DOOR



Composite Door 70mm

-  Composite Door
-  Fully Bevelled
-  28mm Double Glazing
-  Composite Panelling
-  Internally Glazed

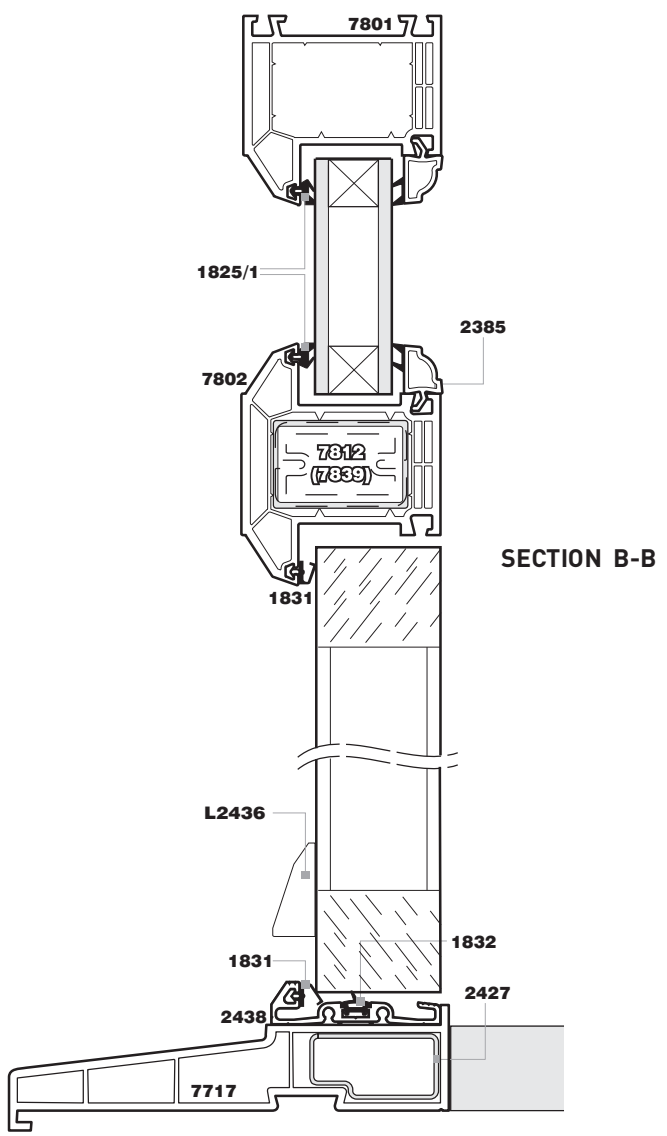
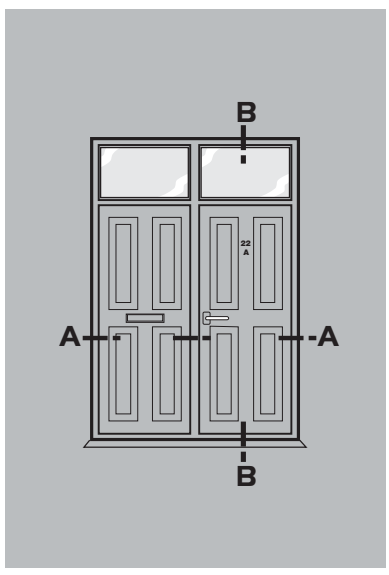

All dimensions are nominal. DO NOT SCALE  
TD-02-0045-1-0\06-08

All information in this publication is provided for guidance only and is given in good faith. As it is company policy to continually improve products, methods and materials, changes of specification may be made from time to time without prior notice. This statement does not affect your statutory rights. ©PROFILE22

# 1 Product



## Door Styles

In-line Sliding Patio Door



# In-line Patio Door System

Horizontal Sections - 86mm Outer Frame, 28mm Double Glazing

CATEGORY	DESCRIPTION	STYLE
PRODUCT	ASSEMBLIES	IN-LINE PATIO DOOR

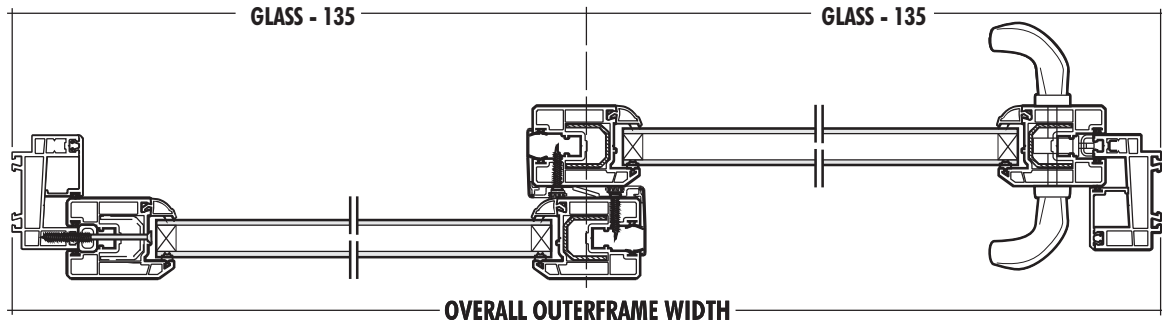

$$\text{EQUAL GLASS WIDTH} = \frac{\text{OVERALL WIDTH} - 270}{2}$$

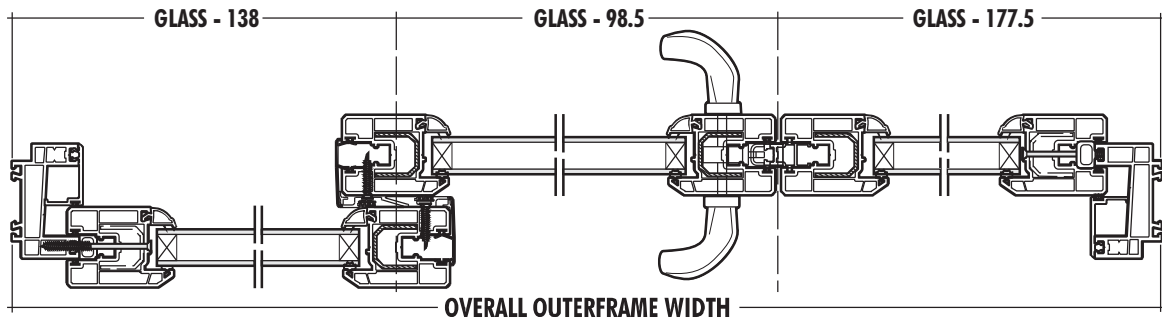

$$\text{EQUAL GLASS WIDTH} = \frac{\text{OVERALL WIDTH} - 414}{3}$$

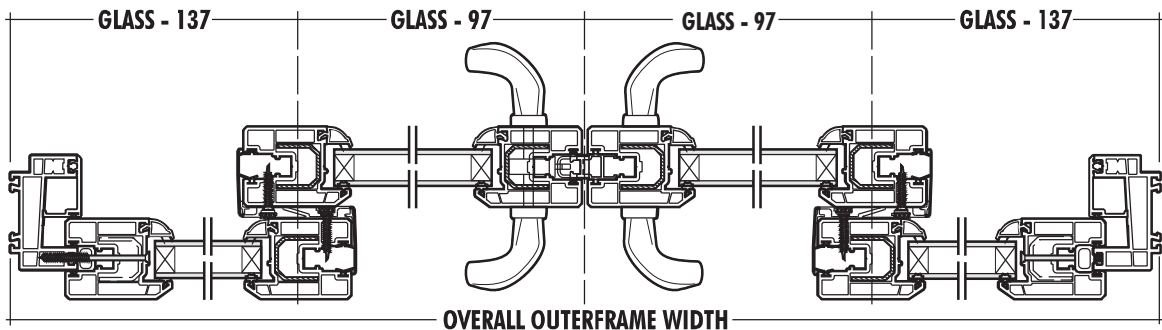

$$\text{EQUAL GLASS WIDTH} = \frac{\text{OVERALL WIDTH} - 468}{4}$$

STANDARD DOUBLE GLAZE UNIT IS 28mm



# In-line Patio Door System

## Vertical Sections - 86mm Outer Frame, 28mm Double Glazing

CATEGORY	DESCRIPTION	STYLE
PRODUCT	ASSEMBLIES	INL-LINE PATIO DOOR



### FULL FRAME THRESHOLD

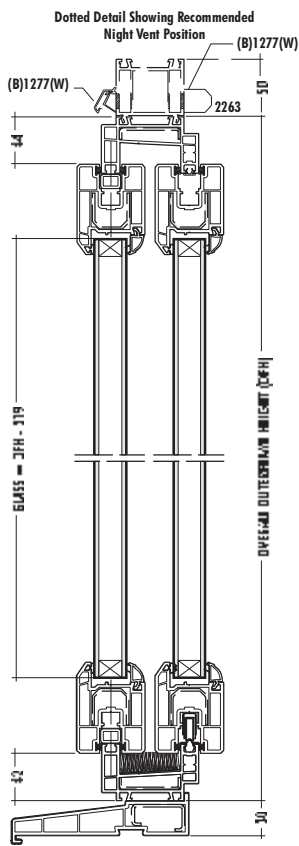

Detail Showing 2217-155mm Cill

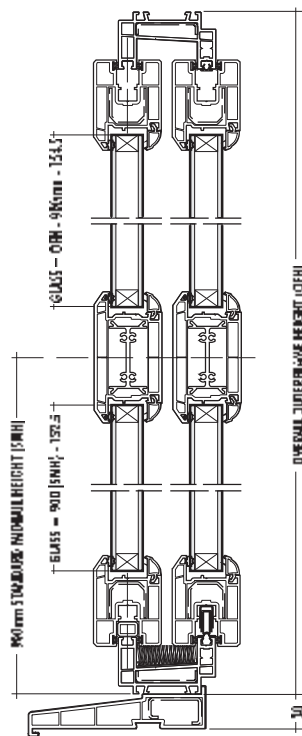

Detail Showing 2217-155mm Cill

### LOW ALUMINIUM THRESHOLD

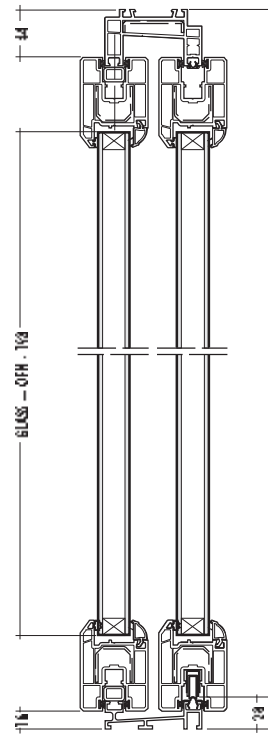

Detail Showing S1224-Low Threshold

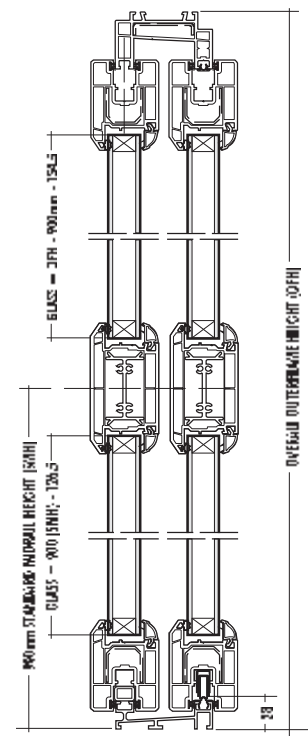

Detail Showing S1224-Low Threshold

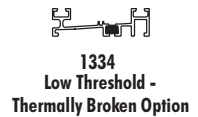

**Note** Overall outerframe height does not include cill. (Profile 22 cill shown).

# 1 Product



Curtain Wall



CATEGORY	DESCRIPTION	STYLE
PRODUCT	ASSEMBLIES	CURTAIN WALL



Curtain Wall System

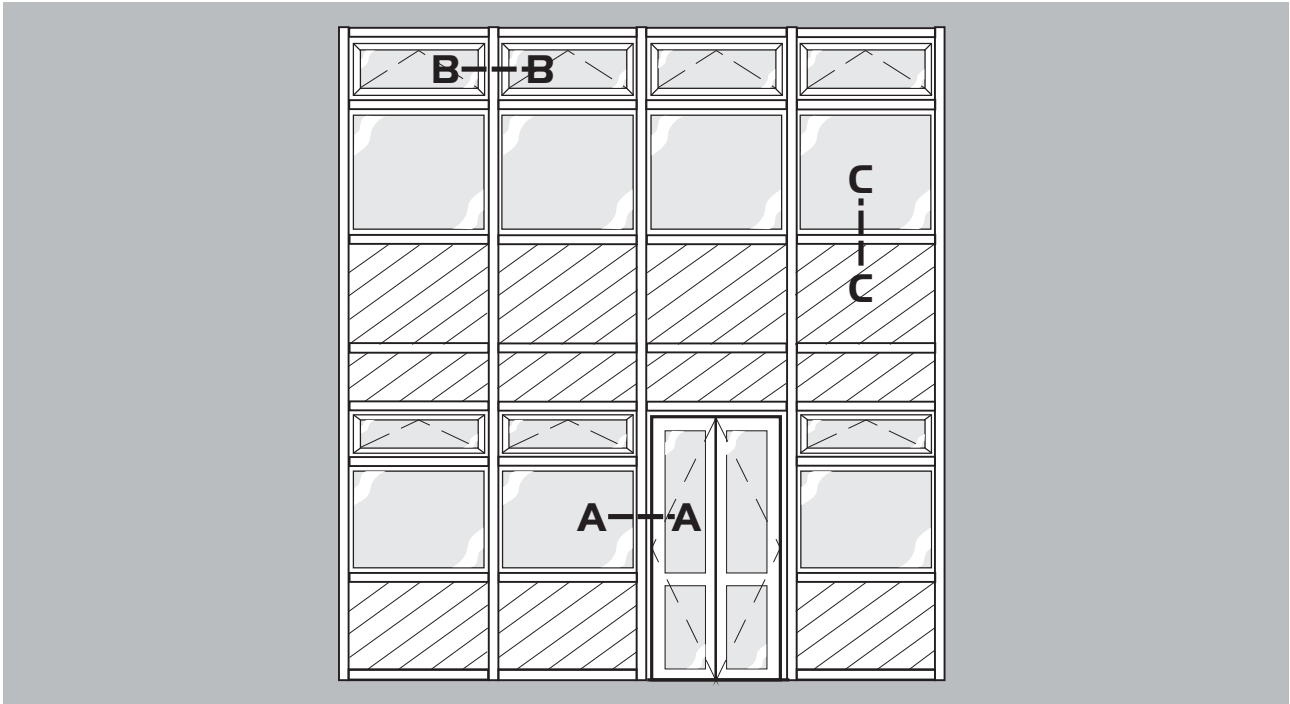

## CURTAIN WALL DOOR DETAIL SECTION A-A

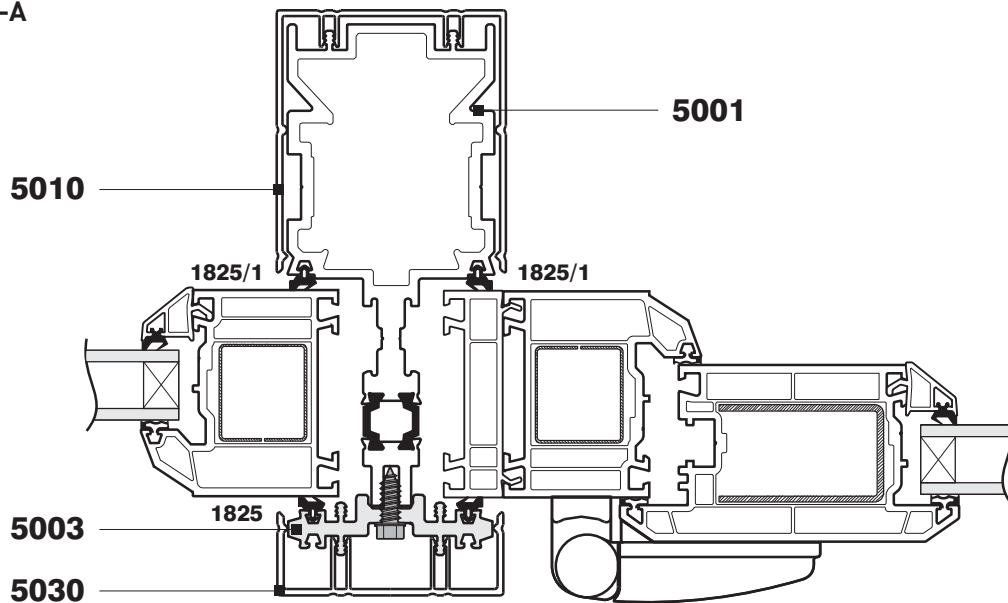

CATEGORY	DESCRIPTION	STYLE
PRODUCT	ASSEMBLIES	CURTAIN WALL



## CURTAIN WALL VENT DETAIL SECTION B-B

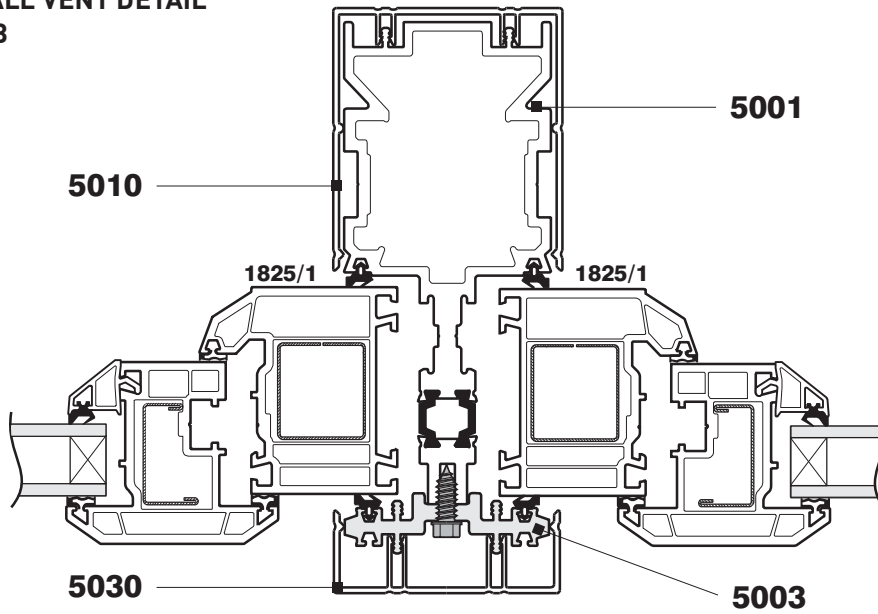

## CURTAIN WALL INSULATION PANEL SECTION C-C

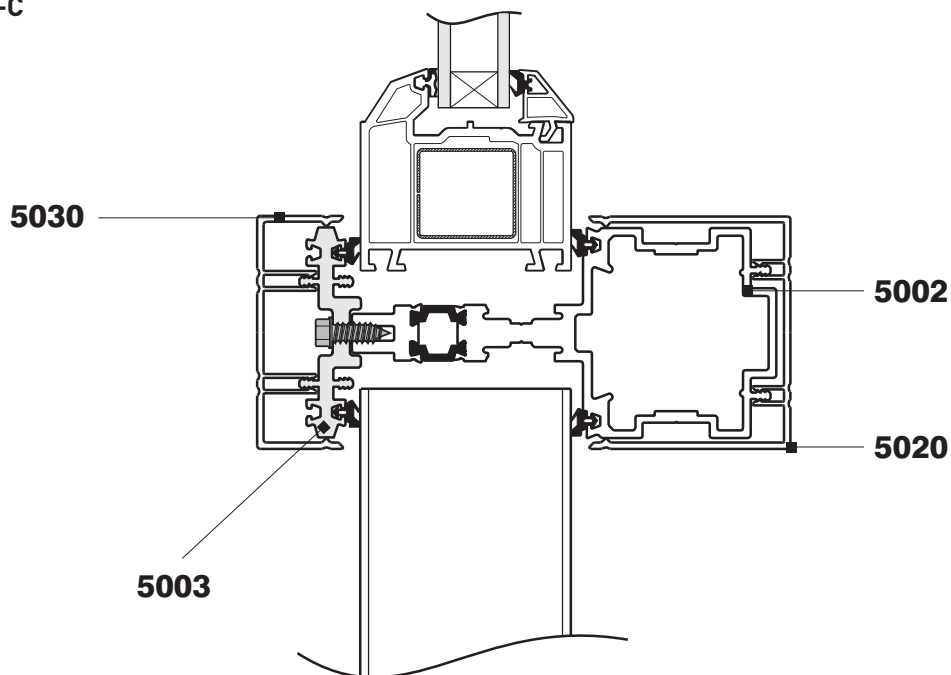

# 1 Product



## New Build

Window Former & Cavity Closer



# 75mm Cavity Closer - Fit Window from Inside

## Fitted with FC60 Internally Beaded Window - Vertical Section

CATEGORY	DESCRIPTION	STYLE
PRODUCT	ASSEMBLIES	WINDOW FORMER, FIXER & CAVITY CLOSER

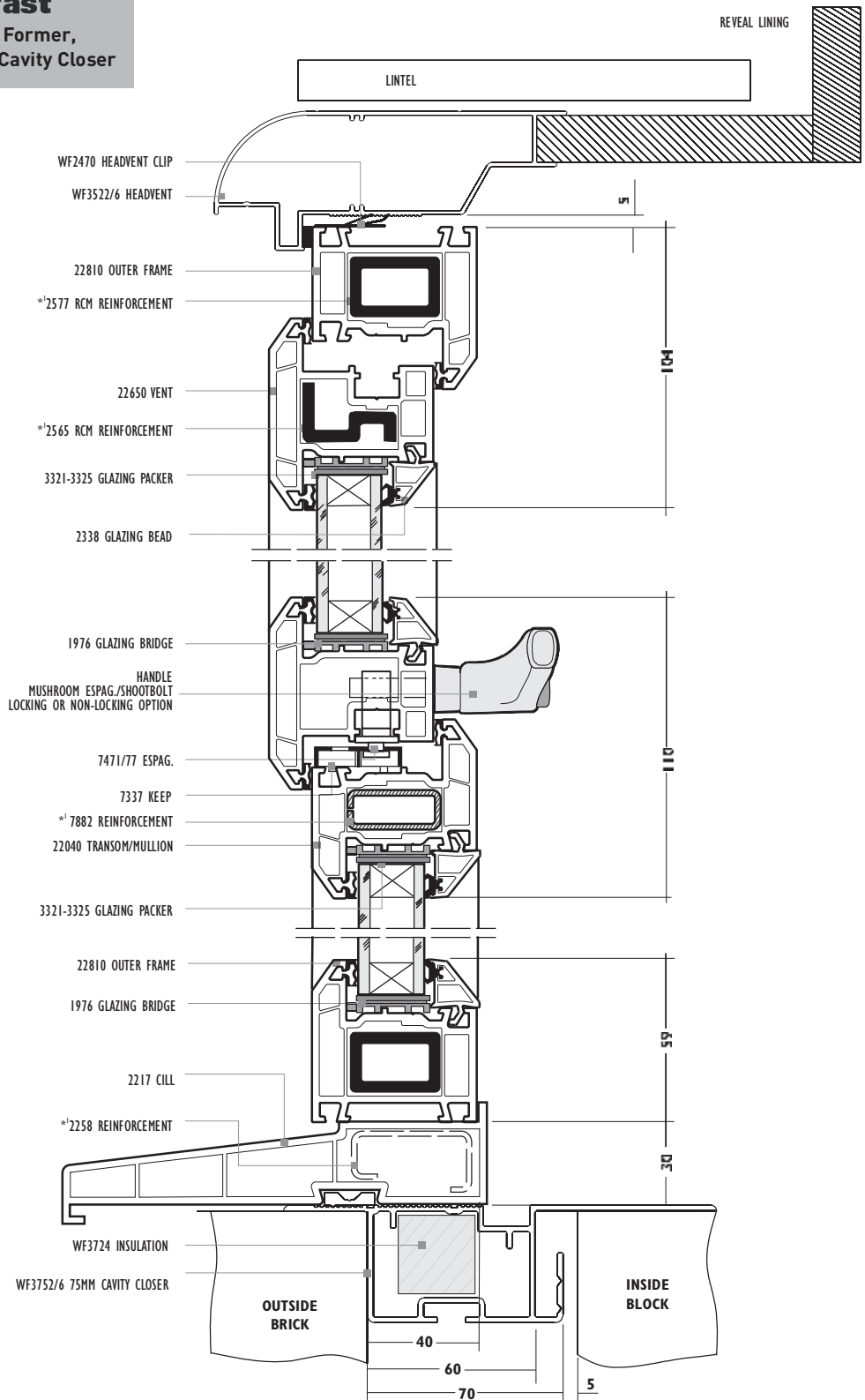

All dimensions are nominal. DO NOT SCALE  
TD-02-0051-1-0\06-08

All information in this publication is provided for guidance only and is given in good faith. As it is company policy to continually improve products, methods and materials, changes of specification may be made from time to time without prior notice. This statement does not affect your statutory rights. ©PROFILE22

# 75mm Cavity Closer - Fit Window from Inside

Fitted with FC60 Internally Beaded Window - Horizontal Section

CATEGORY	DESCRIPTION	STYLE
PRODUCT	ASSEMBLIES	WINDOW FORMER, FIXER & CAVITY CLOSER

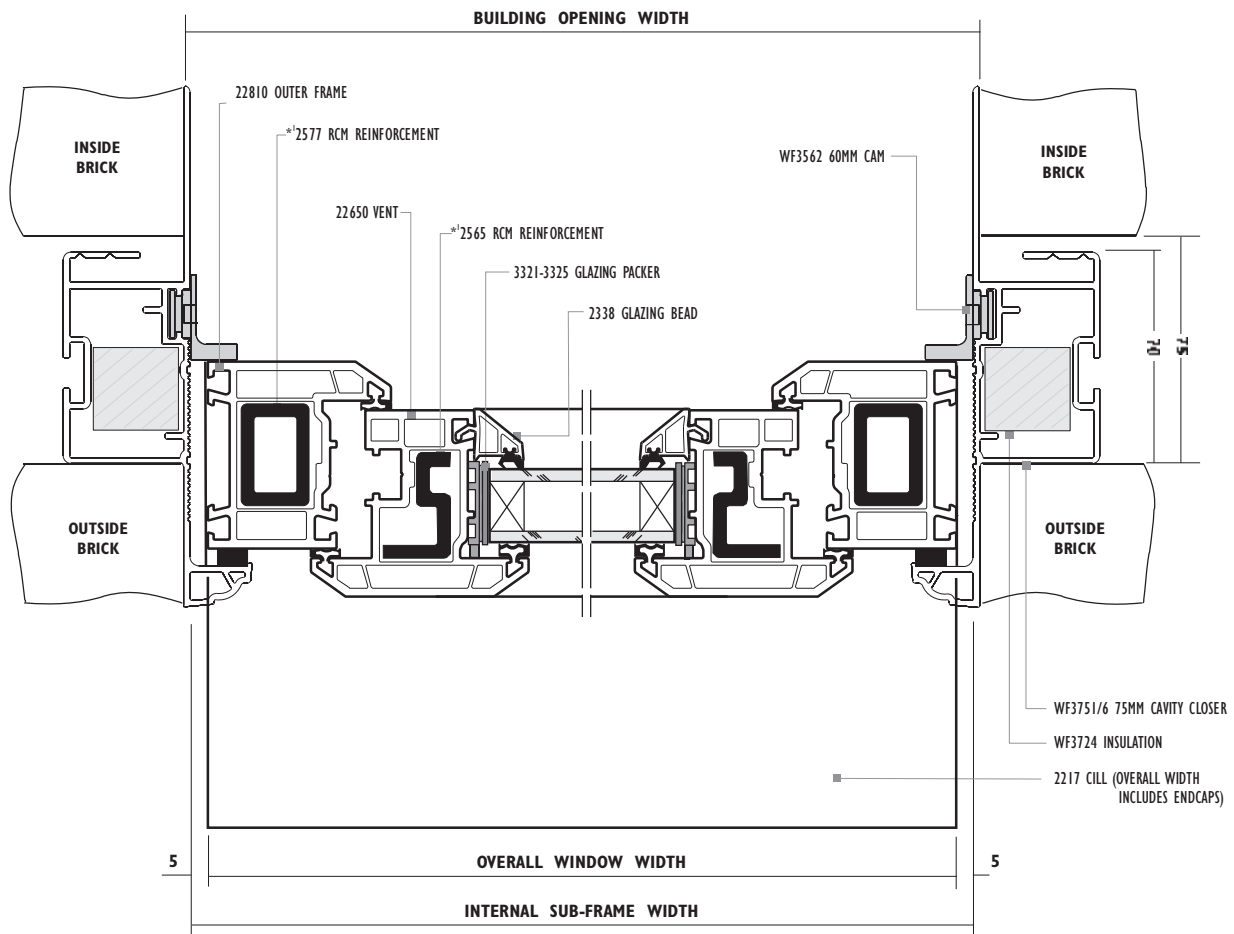

# 90mm Cavity Closer - Fit Window from Inside

Fitted with FC60 Window - Timber Frame Application - Vertical Section

CATEGORY	DESCRIPTION	STYLE
PRODUCT	ASSEMBLIES	WINDOW FORMER, FIXER & CAVITY CLOSER

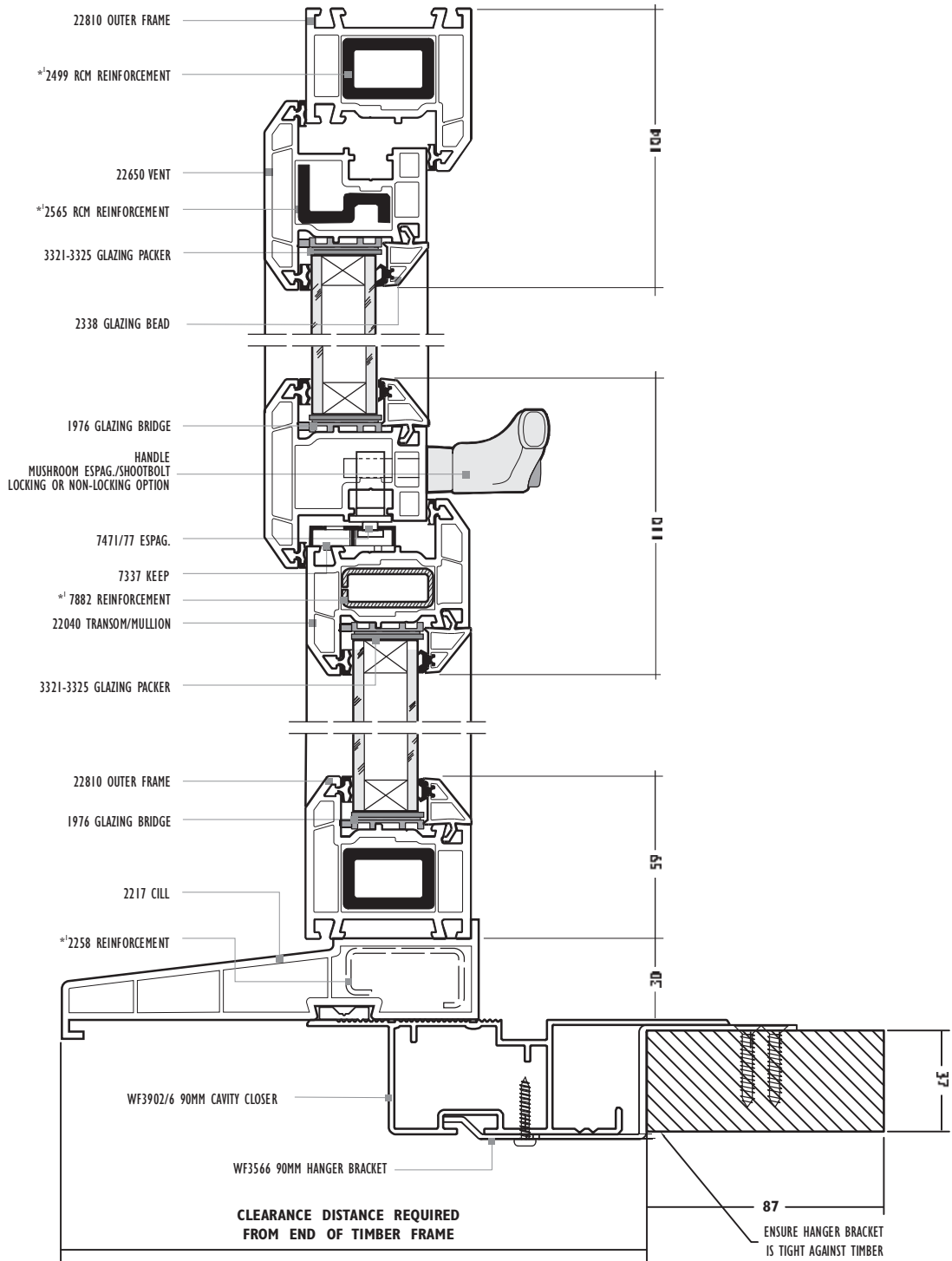

All dimensions are nominal. DO NOT SCALE  
TD-02-0055-1-0\06-08

All information in this publication is provided for guidance only and is given in good faith. As it is company policy to continually improve products, methods and materials, changes of specification may be made from time to time without prior notice. This statement does not affect your statutory rights. ©PROFILE22



# 90mm Cavity Closer - Fit Window from Inside

Fitted with FC60 Window - Timber Frame Application - Horizontal Section

CATEGORY	DESCRIPTION	STYLE
PRODUCT	ASSEMBLIES	WINDOW FORMER, FIXER & CAVITY CLOSER

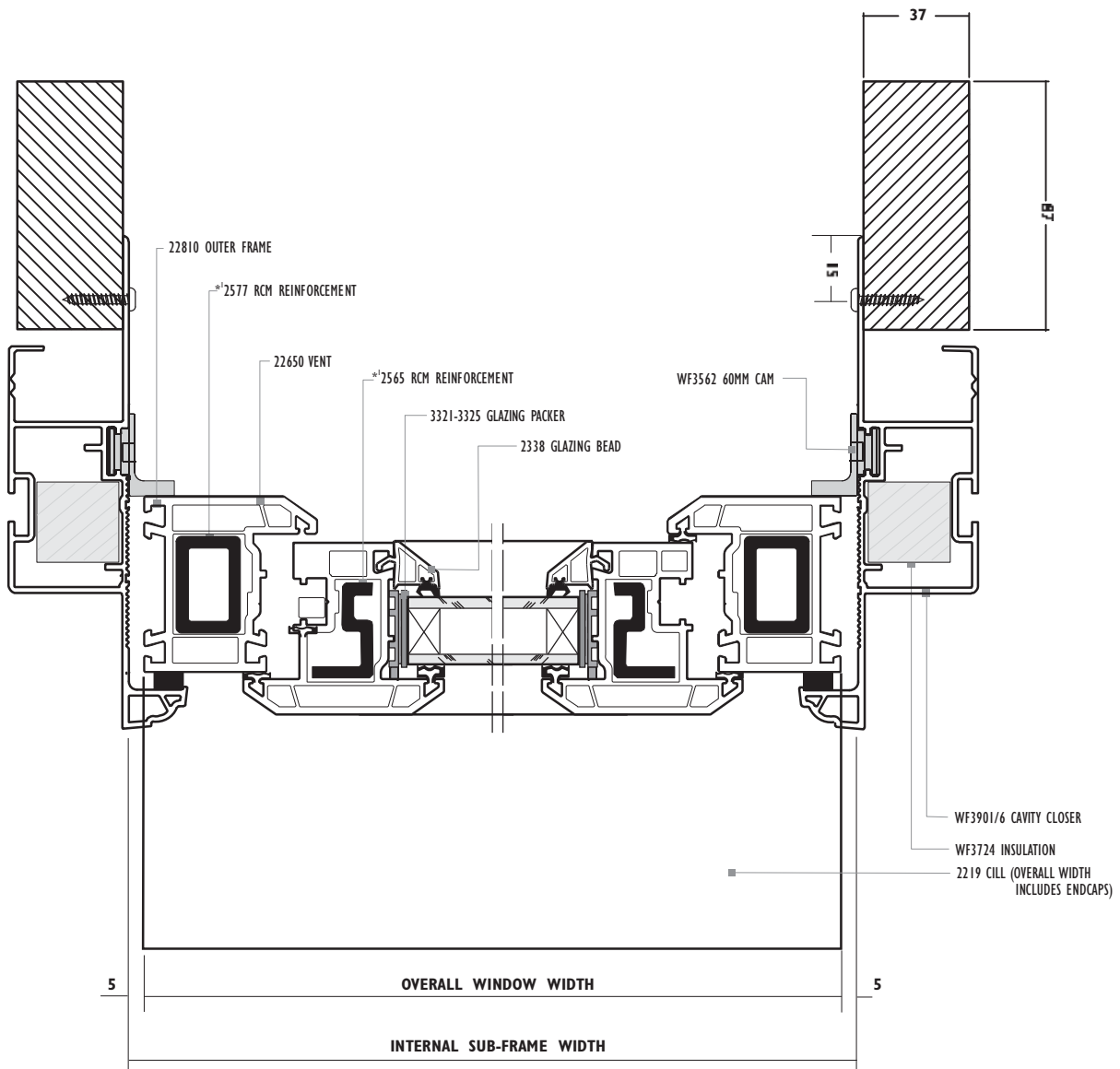

# 100mm Cavity Closer - Fit Window from Inside

## Fitted with FI70 Internally Beaded Window - Vertical Section

CATEGORY	DESCRIPTION	STYLE
PRODUCT	ASSEMBLIES	WINDOW FORMER, FIXER & CAVITY CLOSER

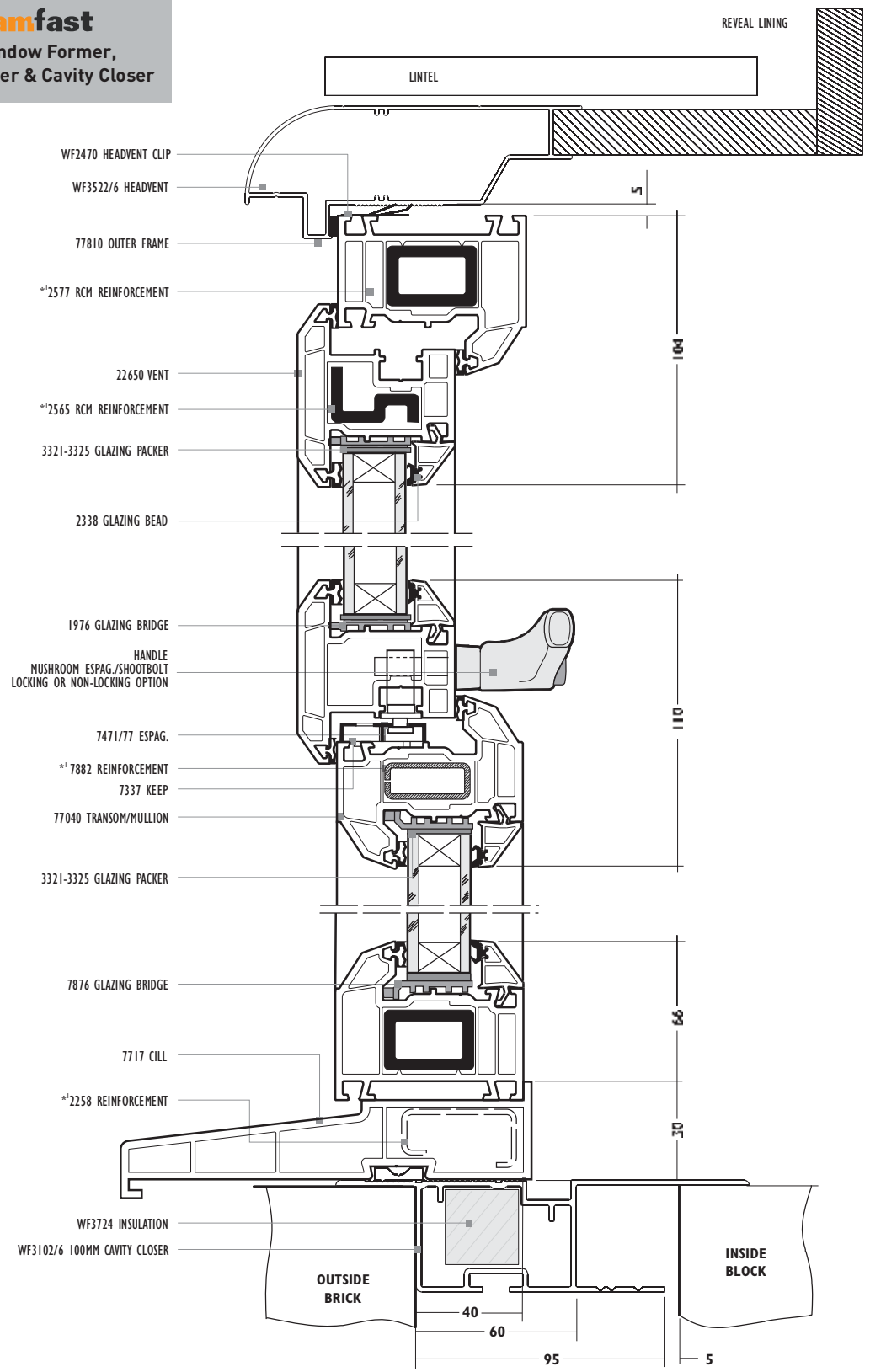

All dimensions are nominal. DO NOT SCALE  
TD-02-0053-1-0\06-08

All information in this publication is provided for guidance only and is given in good faith. As it is company policy to continually improve products, methods and materials, changes of specification may be made from time to time without prior notice. This statement does not affect your statutory rights. ©PROFILE22

# 100mm Cavity Closer - Fit Window from Inside

## Fitted with FI70 Internally Beaded Window - Horizontal Section

CATEGORY	DESCRIPTION	STYLE
PRODUCT	ASSEMBLIES	WINDOW FORMER, FIXER & CAVITY CLOSER

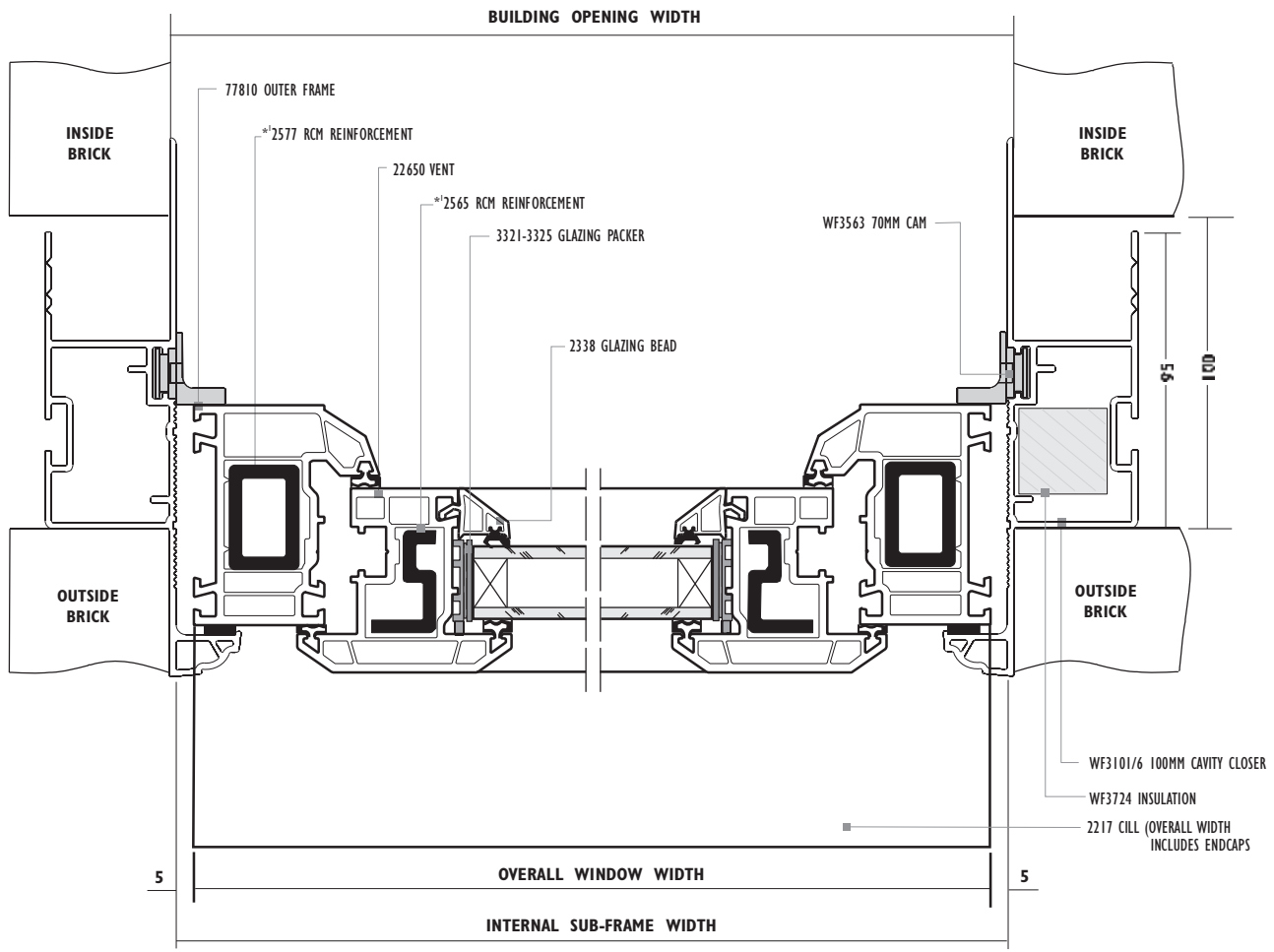

All dimensions are nominal. DO NOT SCALE  
TD-02-0054-1-0\06-08

All information in this publication is provided for guidance only and is given in good faith. As it is company policy to continually improve products, methods and materials, changes of specification may be made from time to time without prior notice. This statement does not affect your statutory rights. ©PROFILE22

# 75mm Cavity Closer - Fit Window from Outside

## Fitted with FC60 Internally Beaded Window - Vertical Section

CATEGORY	DESCRIPTION	STYLE
PRODUCT	ASSEMBLIES	WINDOW FORMER, FIXER & CAVITY CLOSER

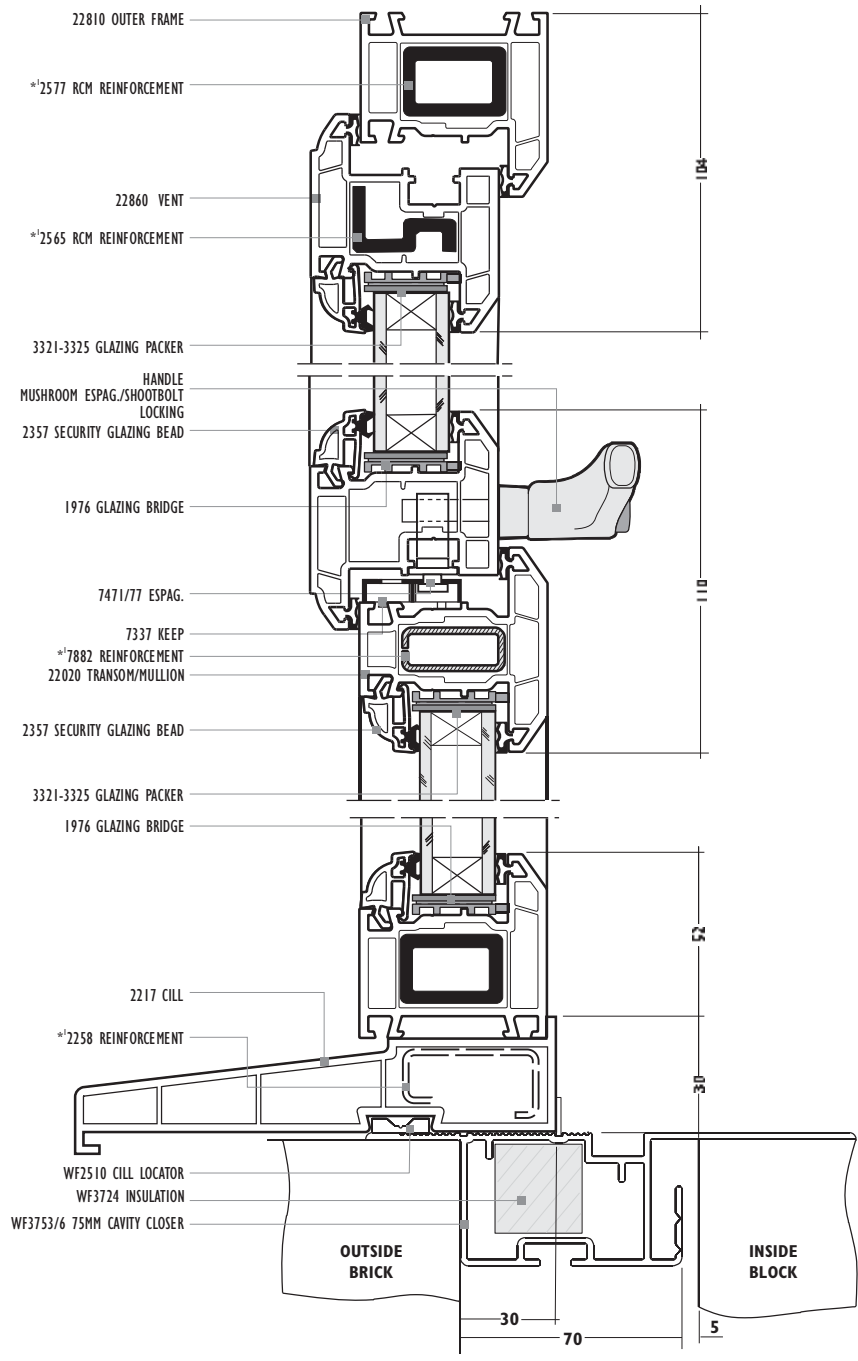

# 75mm Cavity Closer - Fit Window from Outside

## Fitted with FC60 Internally Beaded Window - Horizontal Section

CATEGORY	DESCRIPTION	STYLE
PRODUCT	ASSEMBLIES	WINDOW FORMER, FIXER & CAVITY CLOSER

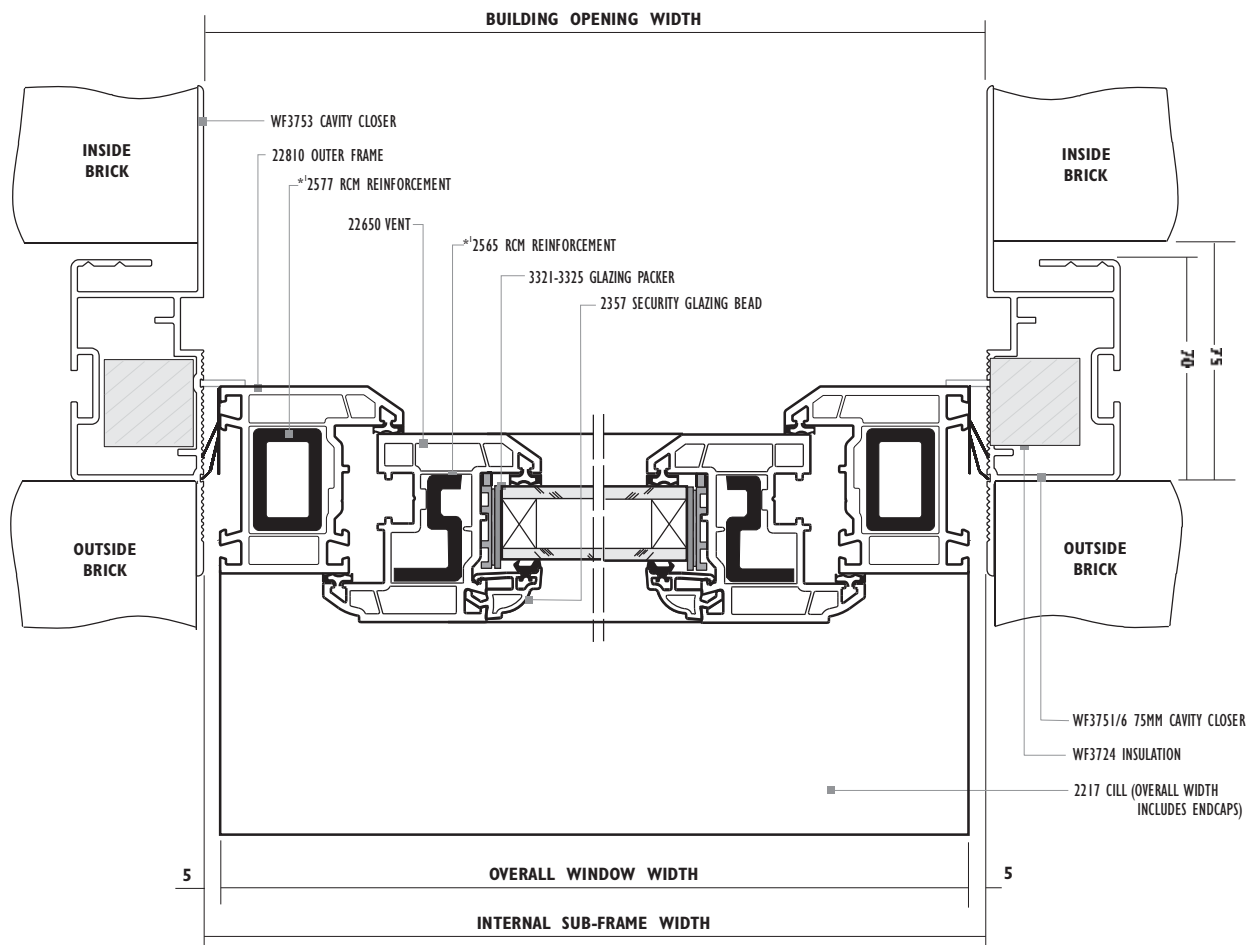

# 100mm Cavity Closer - Fit Window from Outside

Fitted with FC60 Internally Beaded Window - Vertical Section

CATEGORY	DESCRIPTION	STYLE
PRODUCT	ASSEMBLIES	WINDOW FORMER, FIXER & CAVITY CLOSER

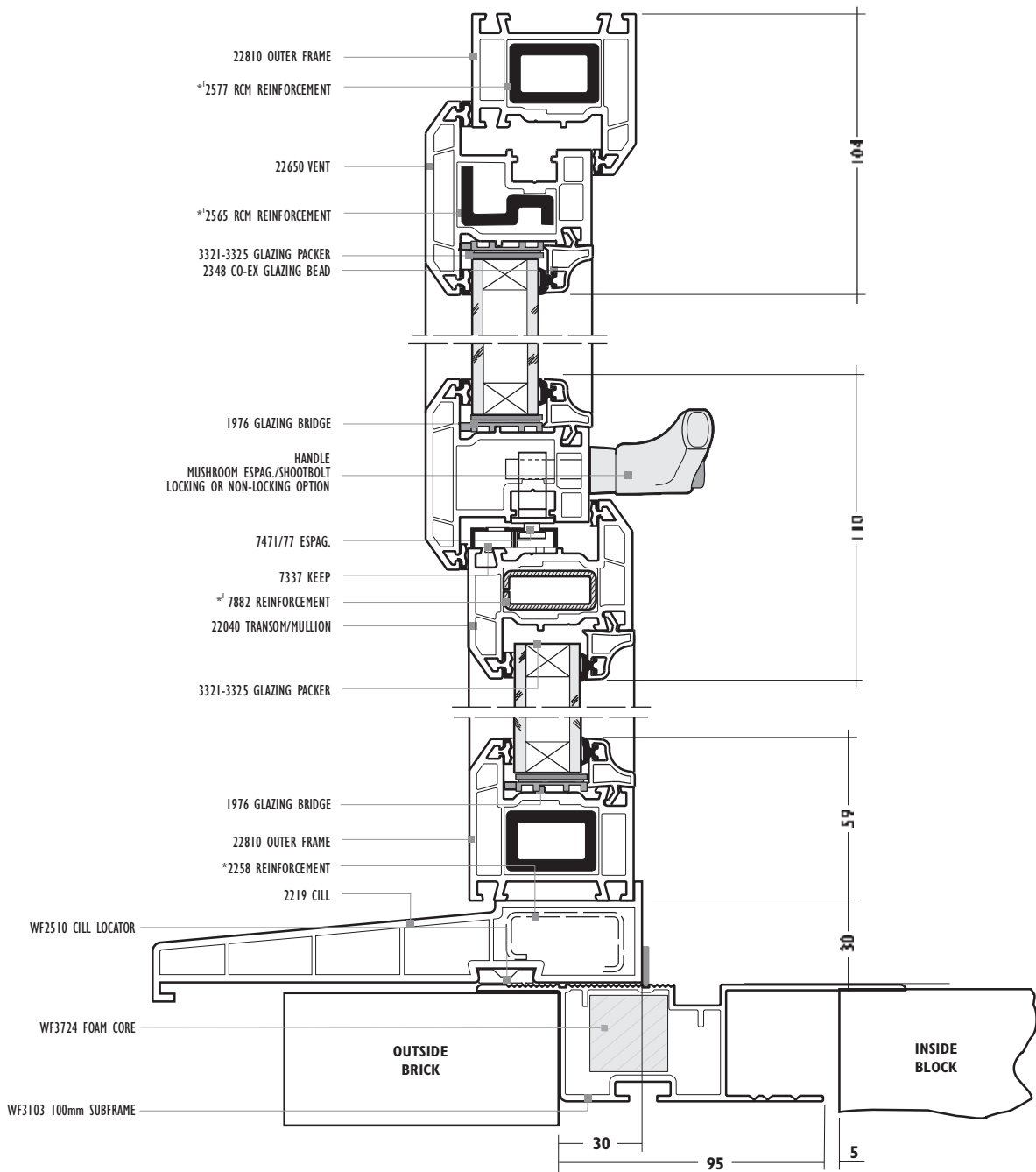

All dimensions are nominal. DO NOT SCALE  
TD-02-0059-1-0\06-08

All information in this publication is provided for guidance only and is given in good faith. As it is company policy to continually improve products, methods and materials, changes of specification may be made from time to time without prior notice. This statement does not affect your statutory rights. ©PROFILE22

# 100mm Cavity Closer - Fit Window from Outside

Fitted with FC60 Internally Beaded Window - Horizontal Section

CATEGORY	DESCRIPTION	STYLE
PRODUCT	ASSEMBLIES	WINDOW FORMER, FIXER & CAVITY CLOSER

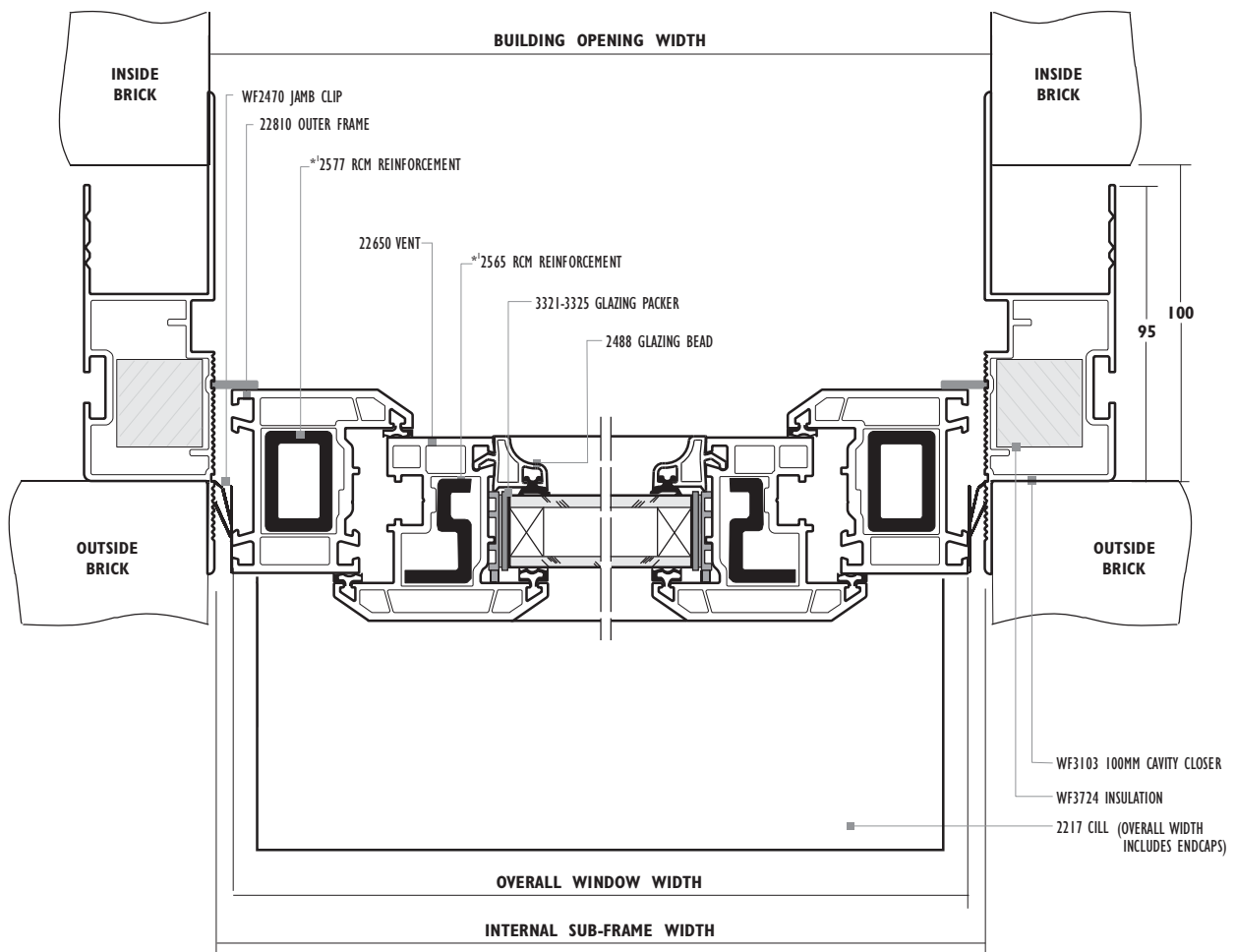

# 2 Product Characteristics



Performance





# Weather Performance

CATEGORY	DESCRIPTION
PRODUCT CHARACTERISTICS	PERFORMANCE

Acceptable levels of window performance are vital to achieve required standards, eliminate costly corrective action, maintain customer confidence and uphold the reputation of the manufacturing company.

Profile and reinforcement choice, window size and configuration will all effect window performance.

The product variations are innumerable and therefore it is impossible to provide predictable performance results.

Standards require that doors and windows meet the specification of BS6375 Part 1, for Air Permeability, Water tightness and Wind Resistance, as shown in the following chart.

TEST	DESIGN WIND PRESSURE		
	1200Pa.	1600Pa.	2000Pa.
<b>AIR PERMEABILITY</b>	200Pa.	300Pa.	300Pa.
<b>WATERTIGHTNESS</b>	100Pa.	200Pa.	200Pa.
<b>WIND RESISTANCE</b>	1200Pa.	1600Pa.	2000Pa.

The units tested shall avoid air and water leakage and resist wind pressures, measured in pascals, for the tests listed and to the values indicated under the three wind pressure categories.

Fabricators/Specifiers are invited to contact the Technical Department for advice, where special wind pressure categories are specified, unusual difficulties may be experienced, or where installation in exposed locations can be expected to be subjected to above average climatic conditions.

The information on Wind Pressure, found within this section, is presented in simplified form and is only intended for guidance.

For detailed information covering all aspect of Wind Loading, Window Performance and Testing etc, refer to the current issue of the following BSI publications.

- (A) BS6375 : Part 1  
Performance of Windows  
Part 1 Classification of Weathertightness
- (B) BS6399 Loading for Buildings  
(Formerly CP3)  
Part 1 Code of Practice for dead and imposed loads  
Part 2 Code of Practice for windloads  
Part 3 Code of Practice for imposed roof loads
- (C) BS5368 : Method of Testing Windows  
Part 1 Air Permeability Test  
Part 2 Watertightness Test  
Part 3 Wind Resistance Test

CATEGORY	DESCRIPTION
PRODUCT CHARACTERISTICS	PERFORMANCE

### WATER TIGHTNESS TO BS 5368 Part 2: 1986 (EN 86)

Test Pressure Pa	Duration of Pressure (min.)	Exposure category (Pa)			
0	15	1200	1600	2000	Special
50	5				
100	5				
150	5				
200	5				
300	5				
400	5				
500	5				

### WIND RESISTANCE TO BS 5368 Part 3: 1985 (EN 77)

Test Pressure Pa	Duration of Pressure (min.)	Exposure category			
1200	3x3 pos. 3x3 neg	1200	1600	2000	Special
1600	3x3 pos. 3x3 neg				
2000	3x3 pos. 3x3 neg				
2400	3x3 pos. 3x3 neg				

The normal maximum permissible deflection for a window with insulating glass units is the length (L) of the mullion/transom divided by (L/175) to a maximum of 16mm. For the insulating glass units it is recommended that the maximum deflection is restricted to 8mm.

For very large windows, e.g. Floor to ceiling glazed screens such as those found in schools and flats, it may be preferable to specify a smaller maximum deflection such as L/250 to provide greater stiffness to the structure. For curtain walling always use L/250.

### EXPOSURES CATEGORIES FOR DOMESTIC SINGLE DOORS & SINGLE DOOR ASSEMBLIES BSI PAS 023-1: 1999

Exposure Category Pa	Air Permeability Pa	Water Tightness Pa	Wind Resistance Pa
800 U	No requirement	No requirement	800
800 X	Up to 200 (graph A)	50	800
800	Up to 200	100	800
Over 800	Up to 300 (graph B)	200	Equal to the actual design wind pressure

# Wind Loads



CATEGORY	DESCRIPTION
PRODUCT CHARACTERISTICS	PERFORMANCE

The maximum Wind Pressure Pascals (Pa) to which an installed unit may be subjected is dependent upon the following:-

- (a) The maximum Wind Speed likely to be experienced at the geographical location of the site.
- (b) The Ground Roughness Category, i.e. The amount of obstruction which will interrupt the air flow.
- (c) The Height above ground.

**Note 1.**

Wind Speeds in excess of 120mph may be experienced on exposed headlands and islands in Northern & Western coastal regions.

**Height Note:**

For building heights above 10m refer to BS Publication BS 6399.

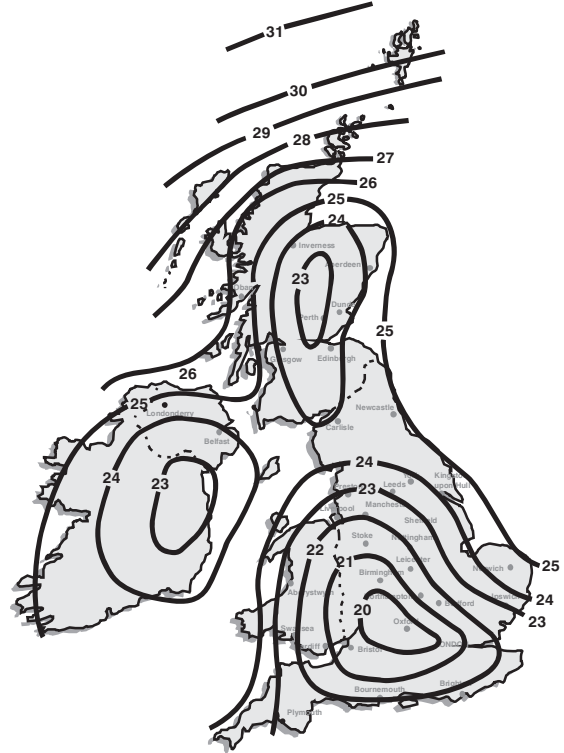

**GROUND ROUGHNESS CHART - WIND PRESSURE (Pa)**

Basic Wind Speed (m/s)	Building Height	CAT. A	CAT. B	CAT. C	CAT. D	CAT. E
		Open country less than 10km from open sea	Open country more than 10km from open sea	Town areas less than 2km from open sea	Town areas bet. 2km and 10km from open sea	Town areas more than 10km from open sea
20	<5m	801	726	645	410	389
	5m - 10m	932	881	821	698	662
21	<5m	883	800	710	452	429
	5m - 10m	1028	971	905	770	730
22	<5m	970	876	780	496	471
	5m - 10m	1128	1066	993	844	801
23	<5m	1059	959	852	542	514
	5m - 10m	1233	1165	1086	923	875
24	<5m	1154	1044	928	590	560
	5m - 10m	1342	1268	1182	1005	954
25	<5m	1252	1134	1007	640	608
	5m - 10m	1457	1376	1282	1090	1034
26	<5m	1354	1226	1090	692	658
	5m - 10m	1575	1488	1387	1179	1119
27	<5m	1460	1322	1174	746	709
	5m - 10m	1699	1605	1495	1272	1206
28	<5m	1570	1422	1263	803	762
	5m - 10m	1827	1726	1608	1368	1298
29	<5m	1684	1525	1355	862	818
	5m - 10m	1960	1851	1726	1467	1392
30	<5m	1802	1632	1450	922	875
	5m - 10m	2098	1982	1846	1570	1490
31	<5m	1925	1742	1549	984	935
	5m - 10m	2240	2116	1971	1677	1590

NOTE:- This table is based upon a maximum wind speed likely to be exceeded only once in 50 years, measured at 3m, 5m & 10m above the ground and a Pressure Coefficient of 1.2