

EXISTING NORTHEAST ELEVATION



PROPOSED NORTHEAST ELEVATION

KEY

- box frames retained & fitted with replacement sashes with hw glazing bars laminated 6.4mm glass (refer to Detail 01)
- box frames retained & fitted with replacement sashes with hw glazing bars laminated 6.4mm glass (refer to Detail 02)
- box frames retained & fitted with replacement sashes with hw glazing bars 4mm crown glass (refer to Detail 03)
- box frames retained & fitted with replacement sashes with hw glazing bars 4mm crown glass (refer to Detail 04)
- box frames retained & fitted with replacement sashes with hw glazing bars laminated 6.4mm glass (refer to Details 05)

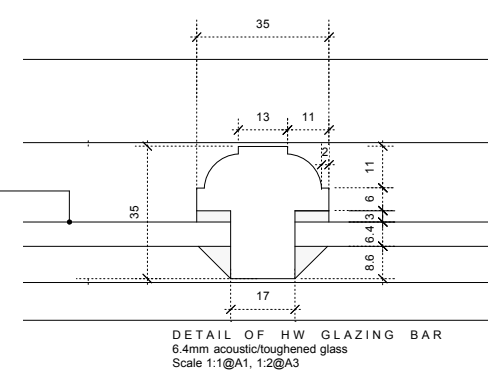
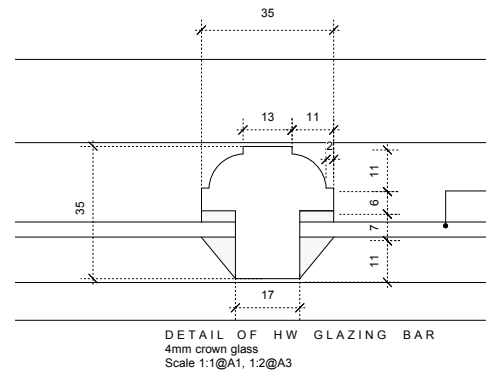

glass specification/thickness varies. (refer to Key Elevation & Details for each floor)

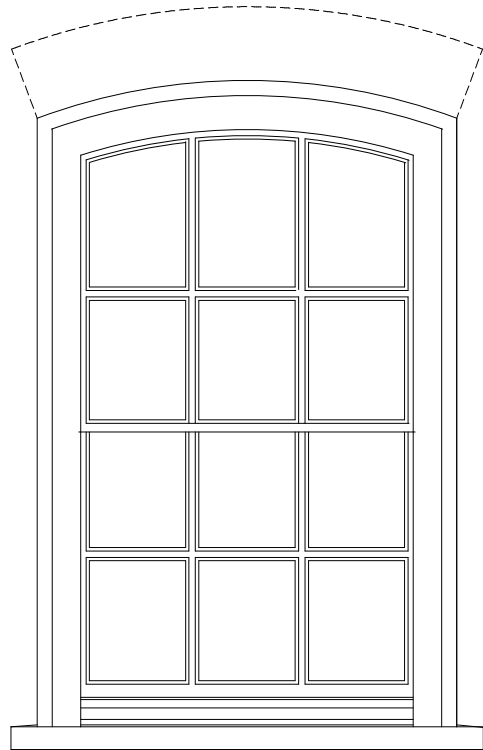

THIRD FLOOR: ELEVATION WT01, WT02, WT03
Scale 1:10@A1, 1:20@A3

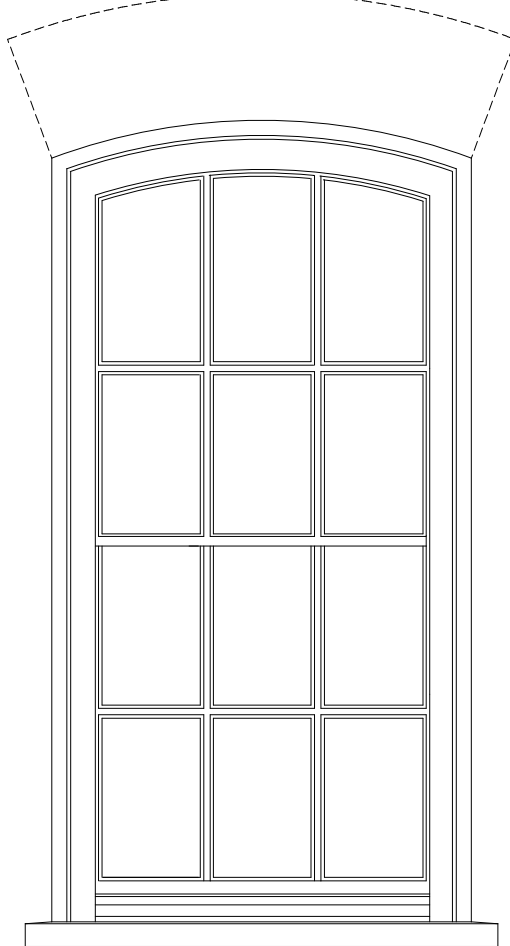

SECOND FLOOR: ELEVATION WS01, WS02, WS03
Scale 1:10@A1, 1:20@A3

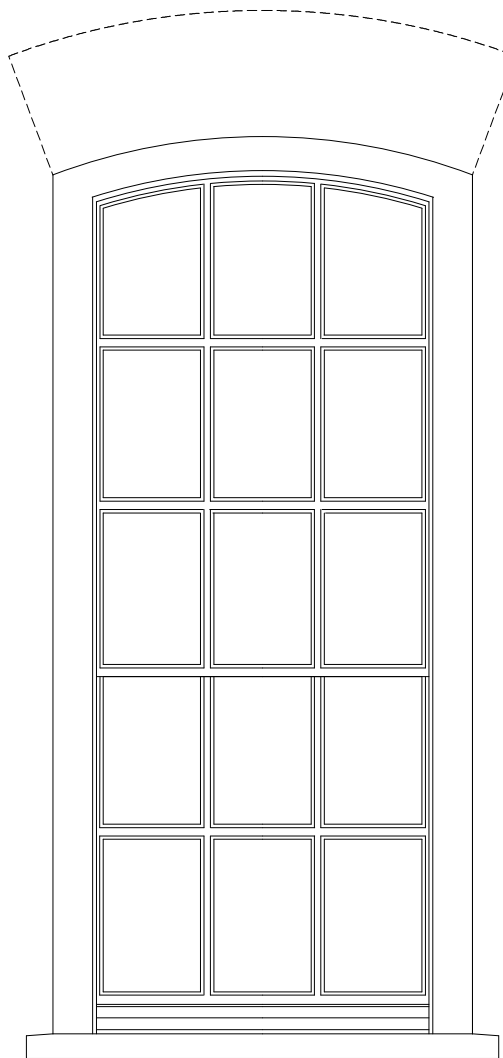

FIRST FLOOR: ELEVATION WF01, WF02, WF03
Scale 1:10@A1, 1:20@A3

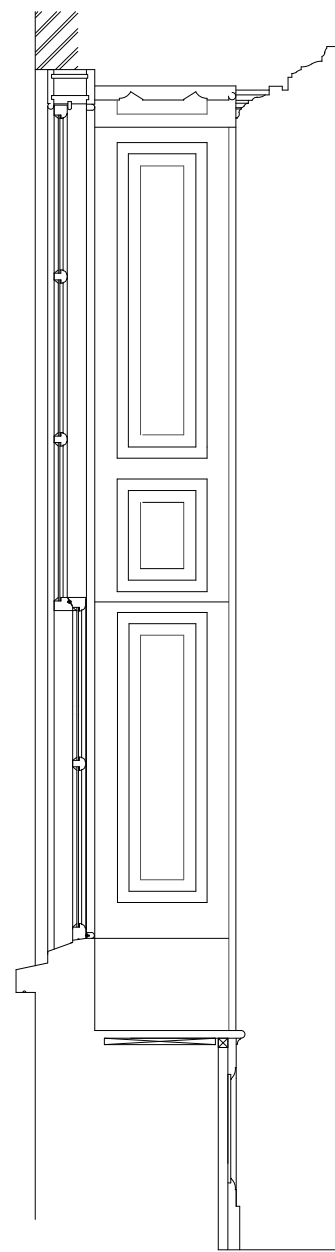

SECTION: FIRST FLOOR WINDOWS

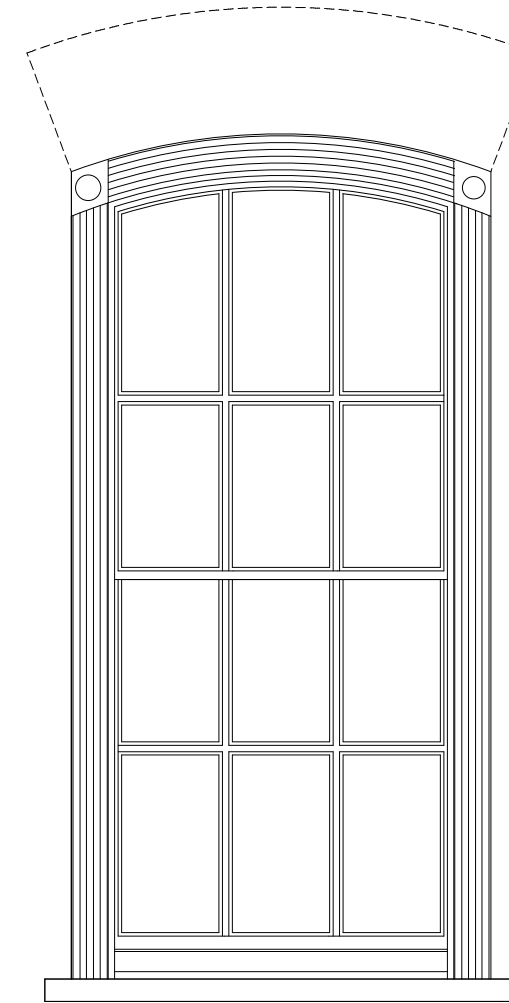

GROUND FLOOR: ELEVATION WG01, WG02, WG03
Scale 1:10@A1, 1:20@A3

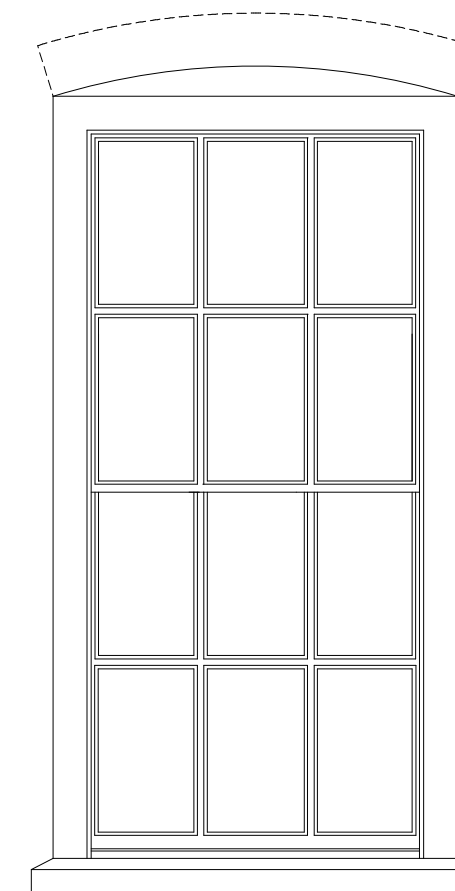

BASEMENT FLOOR: ELEVATION WB01, WB02
Scale 1:10@A1, 1:20@A3

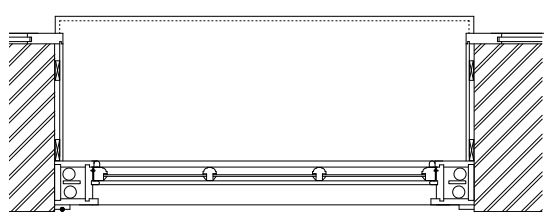

THIRD FLOOR WINDOWS: WT01, WT02, WT03
PLAN DETAILS 01 (1:10@A1, 1:20@A3)
Glass Specification: 6.4mm Acoustic Glass

existing box frame and architrave
new sashes with hw glazing bars

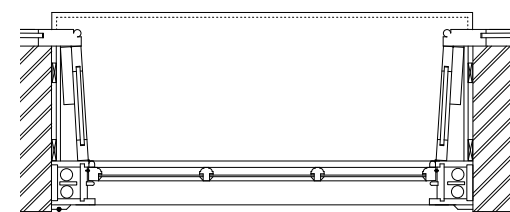

SECOND FLOOR WINDOWS: WS01, WS02, WS03
PLAN DETAILS 02 (1:10@A1, 1:20@A3)
Glass Specification: 6.4mm Acoustic Glass

existing box frame and architrave
new sashes with hw glazing bars

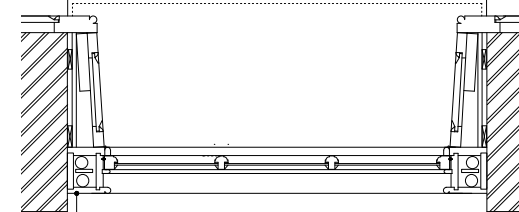

FIRST FLOOR WINDOWS: WF01, WF02, WF03
PLAN DETAILS 03 (1:10@A1, 1:20@A3)
Glass Specification: 4mm Crown Glass

existing box frame, new sashes with hw glazing bars

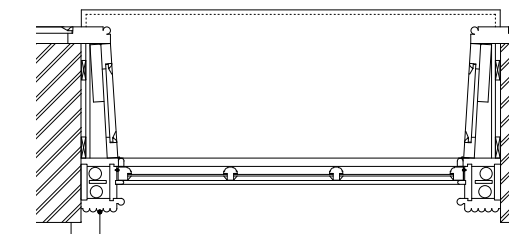

GROUND FLOOR WINDOWS: WG01 & WG02
PLAN DETAILS 04 (1:10@A1, 1:20@A3)
existing box frame & architrave, new sashes with hw glazing bars, 4mm crown glass

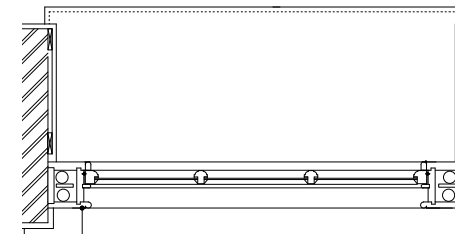

BASEMENT WINDOWS: WB01 & WB02
PLAN DETAILS 05 (1:10@A1, 1:20@A3)
existing box frame fitted with new sashes, hw glazing bars, 6.4mm toughened glass

DO NOT SCALE FROM THIS DRAWING. CHECK ALL DIMENSIONS ON SITE.

REV	DATE	NOTES
A	3.12.13	Existing elevation added for reference, notes amended

DRAWN	PROJECT	TITLE
	31 Great James Street	DETAILS: Windows Front Elevation

CHECKED SCALE: 1:20, 1:10:1 @ A1, 1:40, 1:20, 1:2 @ A3 DATE: November 2013 NO 1257/500 REV A