



Landmark Trees

---

**ARBORICULTURAL IMPACT ASSESSMENT REPORT:**

Gospel Oak Primary School,  
Mansfield Road  
London  
NW3 2JB

**REPORT PREPARED FOR:**

NPS Property Consultants Ltd  
Norwich Office  
Nautilus House  
10 Central Avenue  
St Andrews Business Park  
Norwich  
NR7 0HR

**REPORT PREPARED BY**

Adam Hollis  
MSc ARB MICForFArbor A MRICS C Env

**Ref:** NPS/GOP/AIA/01B

**Date:** 11<sup>th</sup> November 2013

The content and format of this report are for the exclusive use of the client. It may not be sold, lent, hired out or divulged to any third party, not directly involved in the subject matter without Landmark Trees' written consent

---

**Web:** [www.landmarktrees.co.uk](http://www.landmarktrees.co.uk)

**e-mail:** [info@landmarktrees.co.uk](mailto:info@landmarktrees.co.uk)

**Tel:** 0207 851 4544



**London Office:** 20 Broadwick Street, London, W1F 8HT

**Registered Office:** Grange Cottage, All Cannings, Devizes, Wiltshire, SN10 3NR

Landmark Trees is the trading name of Landmark trees Ltd. Registered in Wales. Reg No. 3882076



<b>Section</b>	<b>Content</b>	<b>Page N°</b>
1.0	SUMMARY	5
2.0	INTRODUCTION	6
2.4	Survey Data	8
3.0	OBSERVATIONS	9
4.0	DEVELOPMENT CONSTRAINTS	11
5.0	ARBORICULTURAL IMPACTS	14
6.0	DISCUSSION	16
7.0	CONCLUSION	20
8.0	RECOMMENDATIONS	21
9.0	REFERENCES	24

## **APPENDICES**

APPENDIX 1	Survey Data	25
APPENDIX 2	Recommended Tree Works	29
APPENDIX 3	Recommended Tree Works to Facilitate Development	32
APPENDIX 4	Trees for Constricted Sites	34
APPENDIX 5	Tree Constraints Plan	35
APPENDIX 6	Impact Assessment Plan	37

## Caveats

This report is primarily an arboricultural report. Whilst comments relating to matters involving built structures or soil data may appear, any opinion thus expressed should be viewed as qualified, and confirmation from an appropriately qualified professional sought. Such points are usually clearly identified within the body of the report. It is not a full safety survey or subsidence risk assessment survey. These services can be provided but a further fee would be payable. Where matters of tree condition with a safety implication are noted during a survey they will of course appear in the report.

A tree survey is generally considered invalid in planning terms after 2 years, but changes in tree condition may occur at any time, particularly after acute (e.g. storm events) or prolonged (e.g. drought) environmental stresses or injuries (e.g. root severance). Routine surveys at different times of the year and within two - three years of each other (subject to the incidence of the above stresses) are recommended for the health and safety management of trees remote from highways or busy access routes. Annual surveys are recommended for the latter.

Tree works recommendations are found in the Appendices to this report. It is assumed, unless otherwise stated ("ASAP" or "Option to") that all husbandry recommendations will be carried out within 6 months of the report's first issue. Clearly, works required to facilitate development will not be required if the application is shelved or refused. However, necessary husbandry work should not be shelved with the application and should be brought to the attention of the person responsible, by the applicant, if different. Under the Occupiers Liability Act of 1957, the owner (or his agent) of a tree is charged with the due care of protecting persons and property from foreseeable damage and injury.' He is responsible for damage and/or nuisance arising from all parts of the tree, including roots and branches, regardless of the property on which they occur. He also has a duty under The Health and Safety at Work Act 1974 to provide a safe place of work, during construction. Tree works should only be carried out with local authority consent, where applicable.

Inherent in a tree survey is assessment of the risk associated with trees close to people and their property. Most human activities involve a degree of risk, such risks being commonly accepted if the associated benefits are perceived to be commensurate.

Risks associated with trees tend to increase with the age of the trees concerned, but so do many of the benefits. It will be appreciated, and deemed to be accepted by the client, that the formulation of recommendations for all management of trees will be guided by the cost-benefit analysis (in terms of amenity), of tree work that would remove all risk of tree related damage.

Prior to the commencement of any tree works, an ecological assessment of specific trees may be required to ascertain whether protected species (e.g. bats, badgers and invertebrates etc.) may be affected.

### Tree Constraints & Protection Overview

<b>Client:</b>	NPS Property Consultants Ltd		<b>Case Ref:</b>	NPS/GOP/AIA/01B	
<b>Local Authority:</b>	LB Camden		<b>Date:</b>	11 <sup>th</sup> November 2013	
Site Address: Gospel Oak Primary School, Mansfield Road, London NW3 2JB					
Proposal: Refurbishment & extension with new site access					
<b>Report Checklist</b>			<b>Y/N</b>	<b>Y/N</b>	
Arboricultural constraints on site			Y	Trees removal proposed	
Tree Survey			Y	Topographical Survey	
BS5837 Report			Y	Conservation Area	
Tree Preservation Orders			N/k		
Tree Protection Plan:			N	(Include in future method statement)	
Tree Constraints Plan:			Y		
Arboricultural Impact Assessment:			Y		
<b>Site Layout</b>					
Site Visit	Y	Date: 24/10/13	Access	Full/Partial/None	F
Trees on Site			Y	Off-site Trees	
Trees affected by development			Y	O/s trees affected by development	
Tree replacement proposed:			Y	On or off-site trees indirectly affected by development	
<b>Trees with the potential to be affected</b>					
<p>Category B trees, T1 &amp; 13 incur &lt;5% RPA encroachments for new build, which is rated very low impact.</p> <p>Category C trees 2, 3, 9, 11 &amp; 16 -18 to be felled to facilitate development / remove unsuitable tree species close to existing and proposed buildings (ash &amp; lime).</p> <p>Category U T4 cherry, 7 lime &amp; 10 elder to be felled as poor specimens.</p> <p>Replacement TBC as necessary: site has an abundance of trees</p>					
<b>Comments</b>					
All trees felled are low-poor quality trees. Their loss will not have not a significant impact on conservation area.					
<b>Recommendations</b>					
1	Proposal will mean the loss of important trees (TPO)				N
2	Proposal has sufficient amelioration for tree loss				Y
3	Proposals provide adequate tree protection measures				Y
4	Proposal will mean retained trees are too close to buildings				N
5	Specialist demolition / construction techniques required				Y
6	The Proposal will result in significant root damage to retained trees				N
7	Further investigation of tree condition recommended				N

RPA= Root Protection Area

TPP= Tree Protection Plan

AMS= Arboricultural Method Statement

AIA = Arboricultural Implication Assessment

BS5837: 2012 'Trees in relation to design, demolition and construction – Recommendations'

Arboricultural Impact Assessment Report: Gospel Oak Primary School, Mansfield Road, London NW3 2JB

Prepared for: NPS Property Consultants Ltd, Nautilus House, 10 Central Avenue, St Andrews Business Park, Norwich NR7 0HR

Prepared by: Adam Hollis of Landmark Trees, 20 Broadwick Street, London W1F 8HT

## 1. SUMMARY

- 1.1 This report comprises an arboricultural impact assessment of the proposals for Gospel Oak Primary School, Mansfield Road, London NW3 2JB, reviewing any conflicts between the proposals and material tree constraints identified in our survey.
- 1.2 There are 18 trees surveyed on or around the site, of which 4 are 'B' category \*(Moderate Quality), 11 'C' category \*(Low Quality) and 3 'U' category \*(Unsuitable for Retention). In theory, only moderate quality trees and above are significant material constraints on development. However, the low quality trees will comprise a constraint in aggregate, in terms of at least, replacement planting.
- 1.3 The principal primary impacts in the current proposals are the felling and replacement of Category C trees 2, 3, 9, 11 & 16 -18 to facilitate development. The direct impacts upon these trees are not all so great as to require their automatic removal, but rather to precipitate management decisions over the wisdom of permitting unsuitable tree species (ash, cypress, gean & lime) to grow close to existing and proposed buildings. T4 cherry, T8 ash and T10 elder are also recommended for felling as poor specimens (category U) regardless of development (and as such are discounted from the impact assessment. The loss of the Category C trees is rated as a low impact, with no significant effect on the visual character of the local (conservation) area. Mitigation could take the form of new planting within a landscape scheme. However, this need not necessarily involve further tree planting: the site is well stocked already with an abundance or even superabundance of trees, where open space for the children will also have a premium. Strategic design could allow for a range of native and ornamental plants in the form of shrubs and hedges that would compliment rather than add to the existing abundance of trees, so providing a more sustainable long-term resource for the future.
- 1.4 Impacts to retained trees are negligible: T1 lime & 13 maple incur <5% RPA encroachments from the new build, which is rated very low impact. Low-invasive foundations are specified by way of mitigation, though this is probably overkill, where pre-emptive root pruning at the limits of the extension would suffice. A decision could be made on the strength of trial pits: low-invasive foundations should only be specified in the event of roots >25mm in diameter being discovered in trial pits.
- 1.5 There are no significant secondary impacts from non-residential development. There is no change of land use and the building outline is only marginally different from the existing, with the trees around the boundaries. T13 maple's lowest branch does nearly overhang the building entrance, but we have already recommended on husbandry grounds that this long low lateral branch be reduced back into the main canopy (and so away from the building).
- 1.6 The site has potential for development without impacting significantly on the wider tree population or local landscape. Thus, with suitable mitigation and supervision the scheme is viable.

\*British Standards Institute: Trees in relation to design, demolition and construction BS 5837: 2012 HMSO, London

## 2. INTRODUCTION

### 2.1 Terms of reference

- 2.1.1 LANDMARK TREES were asked by NPS Property Consultants Ltd to provide a survey and an arboricultural impact assessment of proposals for the site: Gospel Oak Primary School, Mansfield Road, London NW3 2JB. The report is to accompany a planning application.
- 2.1.2 The proposals are for refurbishment & extension with new site access. This report will assess the impact on the trees and their constraints, identified in our survey. Although the proposals were known at the time of the survey, Landmark Trees endeavour to survey each site blind, working from a topographical survey, wherever possible, with the constraints plan informing their evolution.
- 2.1.3 I am a Registered Consultant and Fellow of the Arboricultural Association and a Chartered Forester, with a Masters Degree in Arboriculture and 25 years experience of the landscape industry - including the Forestry Commission and Agricultural Development and Advisory Service. I am a UK Registered Expert Witness, trained in single joint expert witness duties. I am also Chairman of the UK & I Regional Plant Appraisal Committee, inaugurated to promote international standards of valuation in arboriculture.

### 2.2 Drawings supplied

- 2.2.1 The drawings supplied by the client and relied upon by Landmark Trees in the formulation of our survey plans are:
- Existing site survey: 13259-103\_2DT
- Proposals: 13-1-1011EYFS-BAS-PL-A-010\_131025

\*In the absence of a full topographical survey, tree positions may be approximate only.

### 2.3 Scope of survey

- 2.3.1 As Landmark Trees' (LT) arboricultural consultant, I surveyed the trees on site on 24<sup>th</sup> November 2013, recording relevant qualitative data in order to assess both their suitability for retention and their constraints upon the site, in accordance with British Standard 5837:2012 Trees in relation to design, demolition and construction – Recommendations [BS5837:2012].
- 2.3.2 Our survey of the trees, the soils and any other factors, is of a preliminary nature. The trees were SURVEYED on the basis of the Visual Tree Assessment method expounded by Mattheck and Breloer (The Body Language of Trees, DoE booklet Research for Amenity Trees No. 4, 1994). LT have not taken any samples for analysis and the trees were not climbed, but inspected from ground level.
- 2.3.3 A tree survey is generally considered invalid in planning terms after 2 years, but changes in tree condition may occur at any time, particularly after acute (e.g. storm events) or prolonged (e.g. drought) environmental stresses or injuries (e.g. root severance). Routine surveys at different times of the year and within two - three years of each other (subject to the incidence of the above stresses) are recommended for the health and safety management of trees remote from highways or busy access routes. Annual surveys are recommended for the latter.
- 2.3.4 The survey does not cover the arrangements that may be required in connection with the laying or removal of underground services.

### 2.4 Survey data & report layout

- 2.4.1 Detailed records of individual trees are given in the survey schedule in Appendix 1 to this report.
- 2.4.2 A site plan identifying the surveyed trees, based on the client's drawings / topographical survey is provided in Appendix 5.
- 2.4.3 This plan also serves as the Tree Constraints Plan with the theoretical Recommended Protection Areas (RPA's), tree canopies and shade constraints, (from BS5837: 2012) overlain onto it. These constraints are then overlain in turn onto the client's proposals to create an Arboricultural Impact Assessment Plan in Appendix 6. General observations and discussion follow, below.

### 3.0 OBSERVATIONS

#### 3.1 Site description



Photograph 1: Satellite view of the site Source: [www.maps.google.co.uk](http://www.maps.google.co.uk)

- 3.1.1 Site Description – Site lies near Kyoto Garden.
- 3.1.2 Site levels: Site is relatively flat.
- 3.1.3 In terms of the British Geological Survey, the site overlies the London Clay Formation (see indicated location on Fig.1 plan extract below), though no information is recorded on the Superficial Deposits.. The associated soils are generally, highly shrinkable clay; e.g. slowly permeable seasonally waterlogged fine loam over clay. Such highly plastic soils are prone to movement: subsidence and heave. The actual distribution of the soil series are not as clearly defined on the ground as on plan and there may be anomalies in the actual composition of gravel, sand, clay, silt and peat content.
- 3.1.4 Clay soils are prone to compaction during development with damage to soil structure potentially having a serious impact on tree health. The design of foundations near problematic tree species will also need to take into consideration subsidence risk. Further advice from the relevant experts on the specific soil properties can be sought as necessary.



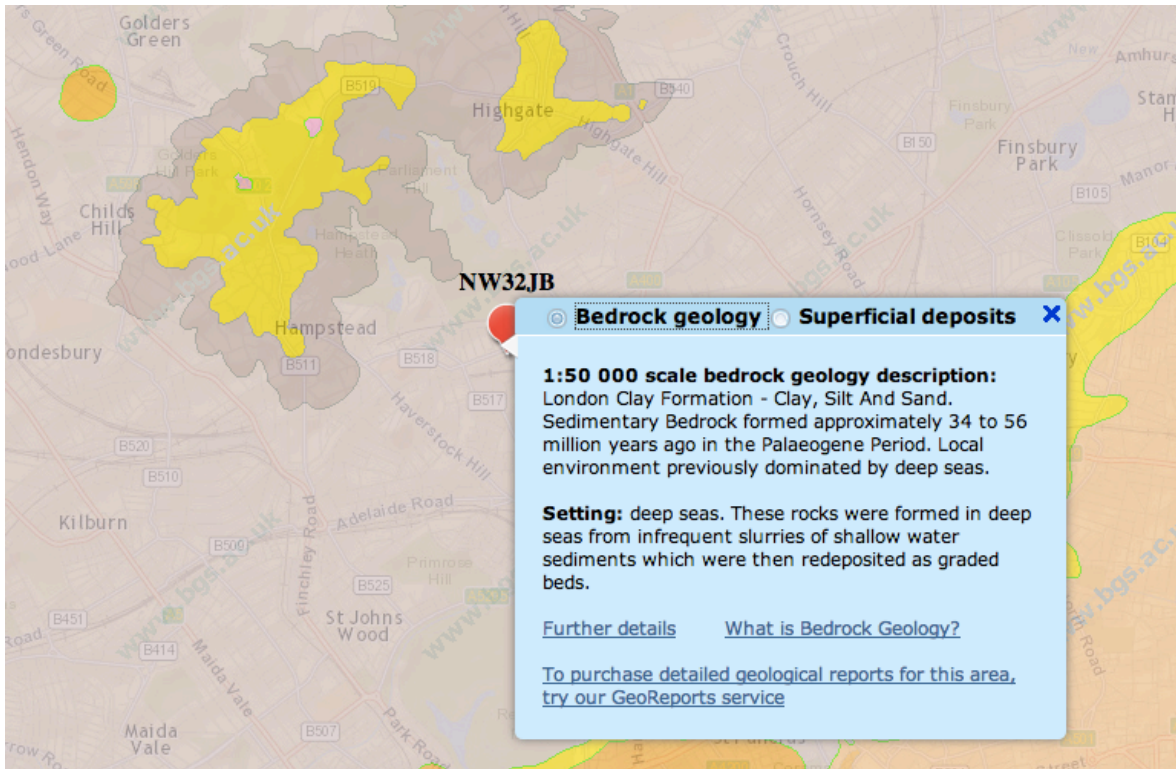

Figure 1: Extract from the BGS Geology of Britain Viewer

### 3.2 Subject trees

3.2.1 The site has 18 trees, of which 4 are 'B' category \*(Moderate Quality), 11 'C' category \*(Low Quality) and 3 'U' category \*(Unsuitable for Retention). In theory, only moderate quality trees and above are significant material constraints on development. However, the low quality trees will comprise a constraint in aggregate, in terms of at least, replacement planting.

3.2.2 The tree species found on site comprise lime, cherry, beech, ash, elder, maple and whitebeam.

3.2.3 In terms of age demographics there is a preponderance of mature trees on the site with few younger, replacement trees in the population.

3.2.4 Full details of the surveyed trees can be found in Appendix 1 of this report.

3.2.5 There are some arboricultural works required within the existing tree population. These are listed in Appendix 2.

### 3.3 Planning Status

3.3.1 We are not aware of the existence of any Tree Preservation Orders, but understand the site stands within the Mansfield Conservation Area, which will affect the subject trees: it is a criminal offence to prune, damage or fell such trees without permission from the local authority.

## 4.0 DEVELOPMENT CONSTRAINTS

### 4.1 Primary constraints

- 4.1.1 BS5837: 2012 gives Recommended Protection Areas (RPA's) for any given tree size. The individual RPA's are calculated in the Tree Schedule in Appendix 1 to this report, or rather the notional radius of that RPA, based on a circular protection zone. The prescribed radius is 12-x stem diameter at 1.5m above ground level, except where composite formulae are used in the case of multi-stemmed trees.
- 4.1.2 Circular RPA's are appropriate for individual specimen trees grown freely, but where there is ground disturbance, the morphology of the RPA can be modified to an alternative polygon, as shown in the diagram below (Figure 2). Alternatively, one need principally remember that RPA's are area-based and not linear – notional rather than fixed entities. **No modifications have been made in this instance (please see overleaf).**

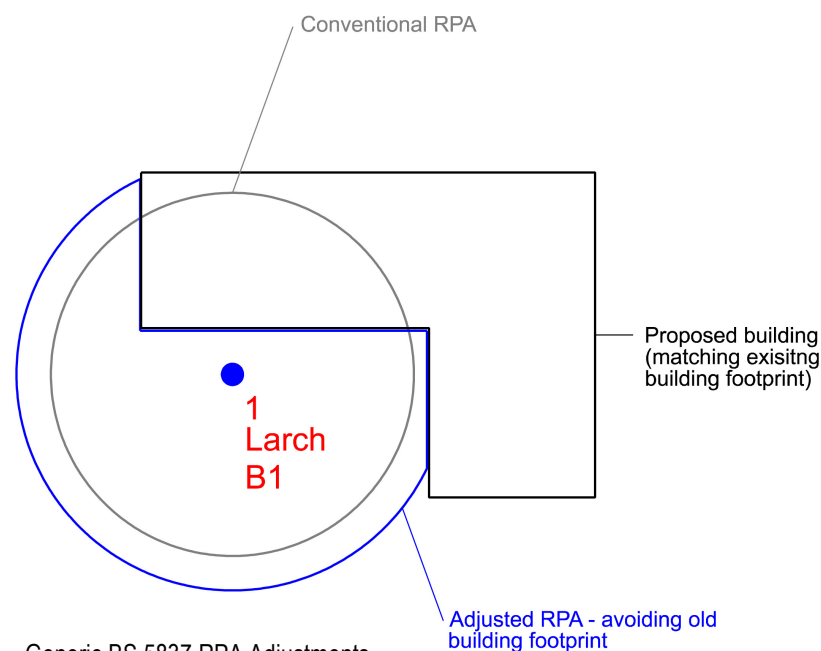

Figure 2 – Generic BS 5837 RPA Adjustments

- 4.1.3 In BS5837, paragraph 4.6.2 states that RPA's should reflect the morphology and disposition of the roots; where pre-existing site conditions or other factors indicate that rooting has occurred asymmetrically, a polygon of equivalent area should be produced. Modifications to the shape of the RPA should reflect a soundly based arboricultural assessment of likely root distribution. Not infrequently, LT are requested by LPA Tree Officers to modify the RPA's to reflect their assumptions that e.g. a road will have drastically limited root growth.

- 4.1.4 Such assumptions cannot be proved without prior site investigations / trial pits. Where it is not always possible to conduct site investigations (e.g. below busy roads), we can always look to the published science. There seems little support for the popular myth that roads and services will curb root growth: research for the International Society of Arboriculture by Kopinga J (ISA 1994), found that “a constant high moisture content of the soil directly underneath the pavement surface can be considered as a major soil factor in attracting the trees’ roots to develop there.” By contrast, grass in lawns may actively antagonise tree roots with natural pathogens. Similarly, Professor F Miller (ISA 1994) found that service trenches at > 3m distances from trees had minimal impact on growth or crown shape.
- 4.1.5 A key misunderstanding, even among professionals, is that we conflate the RPA with the actual root system: RPA's are *prima facie* a notion / convention / treaty and almost entirely theoretical, but readily calculable. Conversely roots are a "known unknown," spatial entity that we predict at our folly. Yet, many are quick to do so.
- 4.1.6 LT favour the neutrality of a circular RPA, because in a difference of opinion, the tree officer will always have the prerogative to dictate the final modification of shape. With the best will in the world, the free allowance of modifications will tend to lead to inequitable outcomes, prejudicing the applicant and the practice is in our view, best avoided. The neutral circle dispenses with this inequity.
- 4.1.7 Ultimately, the point of the circular RPA is to illustrate areas of concern. The purpose of this report is to consider areas of concern (not to modify them to suit our argument or findings). Therefore, no modifications are made here to the RPA's, regardless of roads etc.
- 4.1.8 The quality of trees will also be a consideration: U Category trees are discounted from the planning process in view of their limited service life. Again, Category-C trees would not normally constrain development individually, unless they provide some external screening function.
- 4.1.9 At paragraph 5.1.1. BS5837: 2012 notes that “Care should be exercised over misplaced tree preservation; attempts to retain too many or unsuitable trees on a site are liable to result in excessive pressure on the trees during demolition or construction work, or post-completion demands on their removal.”

- 4.1.10 In theory, only moderate quality trees and above are significant material constraints on development. However, the low quality trees will comprise a constraint in aggregate, in terms of at least, replacement planting. In this instance, there are no internal site trees and therefore few significant primary constraints upon development, provided it will not be necessary to build right up to the boundaries.

## 4.2 Secondary Constraints

4.2.1 The second type of constraint produced by trees that are to be retained is that the proximity of the proposed development to the trees should not threaten their future with ever increasing demands for tree surgery or felling to remove nuisance shading (Figure 3), honeydew deposition or perceived risk of harm.

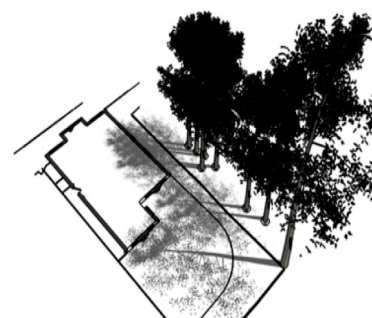

Figure 3 –  
Generic Shading Constraints

4.2.2 The shading constraints are crudely determined from BS5837 by drawing an arc from northwest to east of the stem base at a distance equal to the height of the tree, as shown in the diagram opposite. Shade is less of a constraint on non-residential developments, particularly where rooms are only ever temporarily occupied.

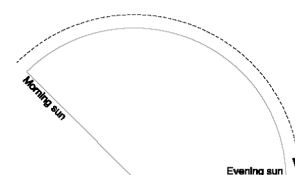

Figure 4 – Shading Arc

4.2.3 This arc (see Figure 4) represents the effects that a tree will have on layout through shade, based on shadow patterns of 1x tree height for a period May to Sept inclusive 10.00-18.00 hrs daily.

4.2.4 Assuming that they will be retained, the orientation of the on-site trees will ensure that shading constraints are minimal, with leaf deposition and honey-dew likely to be as it is today.. The significance of these constraints will vary depending on the location and proximity to the proposed re-development and ongoing land use. We understand the site is to remain a school, where secondary impacts are less of an issue.

*Note: Sections 5 & 6 will now assess the impacts upon constraints identified in Section 4. Table 1 in Section 5 presents the impacts in tabular form (drawing upon survey data presented in Appendices 1 & 2). Impacts are presented in terms of whole tree removal and the effect on the landscape or partial encroachment (% of RPA) and its effect on individual tree health. Section 6 discusses the table data, elaborating upon the impacts' significance and mitigation.*

5.0

# Table 1: Arboricultural Impact Assessment

(Impacts assessed prior to mitigation and rated with reference to From Matheny & Cark (19

Hide irrelevant

Show All Trees

Ref: NPS/GOP/AIA/01

B.S. Cat.	Tree No.	Species	Impact	Tree / RPA Affected	Age	Growth Vitality	Species Tolerance	Impact on Tree Rating	Impact on Site Rating	Mitigation
B	1	Lime, Common	Building Construction within RPA	7.5 m <sup>2</sup> 4.45 %	Mature	Normal	Good	Very Low	N/A	Trial pits / further investigation  Low-invasive foundation design
C	2	Cypress, Leyland	Felled to Facilitate Development	m <sup>2</sup> N/A %	Semi-mature	Normal	N/A	N/A	Low	New planting / landscaping
C	3	Cherry, Ornamental	Felled to Facilitate Development	m <sup>2</sup> N/A %	Semi-mature	Moderate	N/A	N/A	Very Low	New planting / landscaping
U	4	Cherry, Ornamental	Felled to Facilitate Development	m <sup>2</sup> N/A %	Young	Moderate	N/A	N/A	N/A	N/a - Category U
C	9	Ash, Common	Felled to Facilitate Development	m <sup>2</sup> N/A %	Semi-mature	Normal	N/A	N/A	Low	New planting / landscaping
U	10	Elder	Felled to Facilitate Development	m <sup>2</sup> N/A %	Mature	Poor	N/A	N/A	N/A	N/a - Category U

5.0

# Table 1: Arboricultural Impact Assessment

(Impacts assessed prior to mitigation and rated with reference to From Matheny & Cark (19

Hide irrelevant

Show All Trees

Ref: NPS/GOP/AIA/01

B.S. Cat.	Tree No.	Species	Impact	Tree / RPA Affected	Age	Growth Vitality	Species Tolerance	Impact on Tree Rating	Impact on Site Rating	Mitigation
C	11	Ash, Common	Felled to Facilitate Development	m <sup>2</sup> N/A %	Semi-mature	Normal	N/A	N/A	Low	New planting / landscaping
B	13	Maple, Field	Building Construction within RPA	2.5 m <sup>2</sup> 3.83 %	Early Mature	Normal	Moderate	Very Low	N/A	Trial pits / further investigation  Low-invasive foundation design
C	16	Whitebeam, Swedish	Felled to Facilitate Development	m <sup>2</sup> N/A %	Semi-mature	Normal	N/A	N/A	Very Low	New planting / landscaping
C	17	Lime, Common	Felled to Facilitate Development	0.5 m <sup>2</sup> 6.54 %	Semi-mature	Normal	N/A	N/A	Low	New planting / landscaping
C	18	Ash, Common	Felled to Facilitate Development	m <sup>2</sup> N/A %	Young	Normal	N/A	N/A	Low	New planting / landscaping

## 6.0 DISCUSSION

### 6.1 Rating of Primary Impacts

6.1.1 The principal primary impacts in the current proposals are the felling and replacement of Category C trees 2, 3, 9, 11 & 16 -18 to facilitate development. The direct impacts upon these trees are not all so great as to require their automatic removal, but rather to precipitate management decisions over the wisdom of permitting unsuitable tree species (ash, cypress, gean & lime) to grow close to existing and proposed buildings. T4 cherry, T8 ash and T10 elder are also recommended for felling as poor specimens (category U) regardless of development (and as such are discounted from the impact assessment. The loss of the Category C trees is rated as a low impact, with no significant effect on the visual character of the local (conservation) area.

6.1.2 Mitigation could take the form of new planting within a landscape scheme. However, this need not necessarily involve further tree planting: the site is well stocked already with an abundance or even superabundance of trees, where open space for the children will also have a premium. Strategic design could allow for a range of native and ornamental plants in the form of shrubs and hedges that would compliment rather than add to the existing abundance of trees, so providing a more sustainable long-term resource for the future.

6.1.3 Impacts to retained trees are negligible: T1 lime & 13 maple incur <5% RPA encroachments from the new build, which is rated very low impact. Low-invasive foundations are specified by way of mitigation, though this is probably overkill, where pre-emptive root pruning at the limits of the extension would suffice. A decision could be made on the strength of trial pits: low-invasive foundations should only be specified in the event of roots >25mm in diameter being discovered in trial pits.

6.1.4 The principal of RPA encroachment is established within BS5837:2012 and supported by the source document, National Joint Utilities Guidelines 10 / Vol. 4 1995 / 2010. NJUG introduced the x12 diameter *Precautionary Zone* for supervised working and *Prohibited Zone* at a universal 1m from the base of the tree. RPA's are frequently confused with the NJUG Prohibited Zone, when they clearly correlate with the NJUG Precautionary Zone.



- 6.1.5 An RPA encroachment of <20% of RPA may be considered as low impact, given the permissive references to 20% RPA relocation and impermeable paving within BS5837:2012 and other published references to healthy trees tolerating up to 30-50% root severance (Coder, Helliwell and Watson in CEH 2006). The trees in question are healthy specimens of species with a good resistance to development impacts, and quite capable of tolerating these low impacts.
- 6.1.6 **“In practice 50% of roots can sometimes be removed with little problem**, provided there are vigorous roots elsewhere. Inevitably, this degree of root loss will temporarily slow canopy growth and even lead to some dieback” (Thomas 2000). LT do not recommend annexing such high proportions of the root system; rather that within the context of the published science, planning should not be unduly concerned by impacts that are well below the subcritical threshold – *tree health is not at stake*.

## 6.2 Rating of Secondary impacts

- 6.2.1 There are no significant secondary impacts from non-residential development. There is no change of land use and the building outline is only marginally different from the existing, with the trees around the boundaries. T13 maple's lowest branch does nearly overhang the building entrance, but we have already recommended on husbandry grounds that this long low lateral branch be reduced back into the main canopy (and so away from the building)..

### 6.3 Mitigation of Impacts

6.3.1 All plant and vehicles engaged in demolition works should either operate outside the RPA, or should run on a temporary surface designed to protect the underlying soil structure. The demolition of the building should proceed inwards in a “pull down” fashion. Hard surfacing can be lifted with caution by a skilled machine operator again working away from the tree.

6.3.2 The building encroachments may require the use of specialised foundation techniques, such as mini-piling or pad and raised beam, though this requirement could be tested first with trial pits. The foundation pits within the RPA should be trial-excavated by hand using a double-headed spade (“shove-holer”) or similar to minimise breadth of hole required for inspection.

6.3.2 The path of foundations through RPAs will be manually excavated to 750mm depth under arboricultural supervision; any roots encountered within the trenches / pits will be cleanly pruned back to an appropriate junction with a sharp pruning saw or secateurs back to a junction. Roots larger than 25mm diameter may only be cut with LPA consent.

6.3.3 Replacement paving/hard landscaping will require a no-dig construction technique, either using a cellular confinement system with no fines aggregate for the sub-base or simply building upon the existing sub-base without disturbing the ground below. Choice of construction method will initially depend upon root penetration within the existing sub-grade. The key principle is not to excavate in the presence of roots and to provide a porous surface to promote healthy soil water relations for future root growth. A further consideration in the use of a more expensive cellular confinement system or similar, may be the claimed reduction in risk of possible future slab / surface displacement by roots of trees growing in paved areas.

6.3.4 The near canopy encroachment of T13 can be avoided with a crown reduction of lower limbs, affecting a 3m lateral clearance.

6.3.5 Nuisance deposition can be mitigated with regular crown cleaning and filtration traps on the guttering (see Figure 5 below). Alternatively, elements of green roof construction might be considered, where applicable.

6.3.6 Minor shading impacts can be mitigated by building design, with the provision of dual aspect windows and choice of room layout. Some minor crown reduction may be necessary, but not such as to impose a burden of frequent, repetitive management.

6.3.7 The landscape impact of tree losses could be offset by new landscape proposals, ideally involving new planting of ornamental varieties of native species of shrubs, and where appropriate / required of planning with trees of columnar or compact form. A selection of columnar tree species cultivars for constricted sites is provided in Appendix 4.

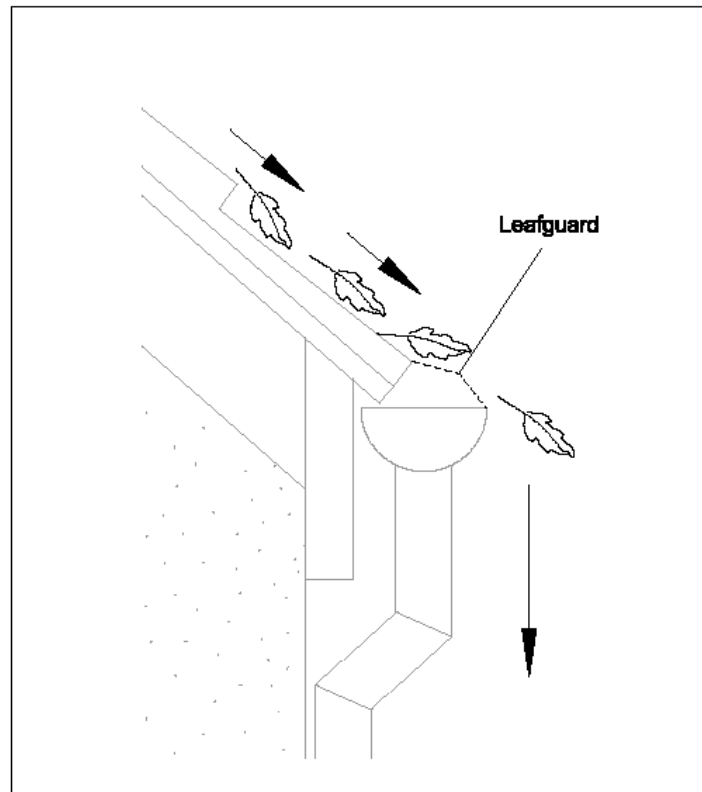

Figure 5: Filtration traps, as shown above, could be fitted on the gutters which can easily be maintained at 2-3m above ground.

## 7.0 CONCLUSION

- 7.1 The potential impacts of development are all relatively low in terms of both quality of trees removed and also RPA encroachments of trees retained.
- 7.2 The full potential of the impacts can be largely mitigated through design and precautionary measures. These measures can be elaborated in Method Statements in the discharge of planning conditions.
- 7.3 The species affected are generally tolerant of root disturbance / crown reduction and the retained trees are generally in good health and capable of sustaining these reduced impacts.
- 7.4 The trees that are recommended for felling are of little individual significance, such that their loss will not affect the visual character of the area.
- 7.5 Therefore, the proposals will not have any significant impact on either the retained trees or wider landscape.

## 8.0 RECOMMENDATIONS

### 8.1 Specific Recommendations

- 8.1.1 Current tree works recommendations are found in Appendix 2 to this report, with works to facilitate development in Appendix 3 and a selection of columnar tree species cultivars for constricted sites provided in Appendix 4. Any tree removals recommended within this report should only be carried out with local authority consent.
- 8.1.2 Excavation and construction impacts within the RPA's of trees identified in Table 1 above, will need to be controlled by method statements specifying mitigation methods suggested in para 6.3 above and by consultant supervision as necessary. These method statements can be provided as part of the discharge of conditions.
- 8.1.3 Replace felled trees with a mix of native and ornamental shrub and hedge species (TBC), or if required of planning, tree species, planted under current best practice; i.e. conforming to and planted in accordance with the following:

- BS 3936:1980 Nursery Stock;
- BS 4043:1966 Transplanting Semi-Mature Trees; and
- BS 5236:1975 Cultivation and Planting of Trees in the Advanced Nursery Stock Category.
- All replacement stock should be planted and maintained as detailed in BS 4428:1989 (Section 7): Recommendations for General Landscape Operations.

## 8.2 General Recommendations

- 8.2.1 Any trees which are in close proximity to buildings proposed for demolition should be protected with a Tree Protection Barrier (TPB). This TPB should comprise steel, mesh panels 2.4m in height ('Heras') and should be mounted on a scaffolding frame (shown in Fig 2 of BS5837:2012). The position of the TPB can be shown on plan as part of the discharge of conditions, once the lay out is agreed with the planning authority. The TPB should be erected prior to commencement of works, remain in its original form on-site for the duration of works and removed only upon full completion of works.
- 8.2.2 A TPB may no longer be required during soft landscaping work but a full arboricultural assessment must be performed prior to the undertaking of any excavations within the RPA of a tree. This will inform a decision about the requirement of protection measures. It is important that all TPBs have permanent, weatherproof notices denying access to the RPA.
- 8.2.3 The use of heavy plant machinery for building demolition, removal of imported materials and grading of surfaces should take place in one operation. The necessary machinery should be located above the existing grade level and work away from any retained trees. This will ensure that any spoil is removed from the RPAs. It is vital that the original soil level is not lowered as this is likely to cause damage to the shallow root systems.
- 8.2.4 Any pruning works must be in accordance with British Standard 3998:2010 Tree work [BS3998].
- 8.2.5 Where sections of hard surfacing are proposed in close proximity to trees, it is recommended that "No-Dig" surfacing be employed in accordance with BS5837:2012 and 'The Principles of Arboricultural Practice: Note 1, Driveways Close to Trees, AAIS 1996 [APN1]'.
- 8.2.6 If the RPA of a tree is encroached by underground service routes then BS5837:2012 and NJUG VOLUME 4 provisions should be employed. If it is deemed necessary, further arboricultural advice must be sought.
- 8.2.7 Numerous site activities are potentially damaging to trees e.g. parking, material storage, the use of plant machinery and all other sources of soil compaction. In operating plant, particular care is required to ensure that the operational arcs of excavation and lifting machinery, including their loads, do not physically damage trees when in use.
- 8.2.8 To enable the successful integration of the proposal with the retained trees, the following points will need to be taken into account:
- 1) Plan of underground services.
  - 2) Schedule of tree protection measures, including the management of harmful substances.

- 3) Method statements for constructional variations regarding tree proximity (e.g. foundations, surfacing and scaffolding).
- 4) Site logistics plan to include storage, plant parking/stationing and materials handling.
- 5) Tree works: felling, required pruning and new planting. All works must be carried out by a competent arborist in accordance with BS3998.
- 6) Site supervision: the Site Agent must be nominated to be responsible for all arboricultural matters on site. This person must:
  - be present on site for the majority of the time;
  - be aware of the arboricultural responsibilities;
  - have the authority to stop work that is causing, or may cause harm to any tree;
  - ensure all site operatives are aware of their responsibilities to the trees on site and the consequences of a failure to observe these responsibilities;
  - make immediate contact with the local authority and/or a retained arboriculturalist in the event of any tree related problems occurring.

8.2.9 These points can be resolved and approved through consultation with the planning authority via their Arboricultural Officer.

8.2.10 The sequence of works should be as follows:

- i) initial tree works: felling, stump grinding and pruning for working clearances;
- ii) installation of TPB for demolition & construction;
- iii) installation of underground services;
- iv) installation of ground protection;
- v) main construction;
- vi) removal of TPB;
- vii) soft landscaping.

## 9.0 REFERENCES

- Barlow JF & Harrison G. 1999. Shade By Trees, Arboricultural Practice Note 5, AAIS, Farnham, Surrey.
- British Standards Institute. 2012. Trees in Relation to Design, Demolition and Construction - Recommendations BS 5837: 2012 HMSO, London.
- Centre for Ecology & Hydrology. 2006. Tree Roots in the Built Environment, HMSO, London.
- Helliwell R (1980) Provision for New Trees; Landscape Design; July/August issue
- International Society of Arboriculture (ISA). 1994. The Landscape Below Ground. ISA, Champaign, Illinois. USA.
- Lonsdale D 1999. Research for Amenity Trees No.7: Principles of Tree Hazard Assessment and Management, HMSO, London.
- Matheny, N; Clark, J. R.1998. Trees and Development: A Technical Guide to Preservation of Trees during Land Development. ISA, Champaign, Illinois. USA.
- Mattheck C. & Breloer H. 1994. Research for Amenity Trees No.2: The Body Language of Trees, HMSO, London.
- Thomas P, 2000. Trees: Their Natural History, Cambridge University Press, Cambridge.
- Trowbridge J & Bassuk N (2004) Trees in the Urban Landscape: Site Assessment, Design, and Installation; J Wiley & Sons inc. NJ USA



## APPENDIX 1

### TREE SCHEDULE

#### Notes for Guidance:

1. Height describes the approximate height of the tree measured in metres from ground level.
2. The Crown Spread refers to the crown radius in meters from the stem centre and is expressed as an average of NSEW aspect if symmetrical.
3. Ground Clearance is the height in metres of crown clearance above adjacent ground level.
4. Stem Diameter (Dm) is the diameter of the stem measured in millimetres at 1.5m from ground level for single stemmed trees. BS 5837:2012 formula (Section 4.6) used to calculate diameter of multi-stemmed trees. Stem Diameter may be estimated where access is restricted and denoted by '#'.
5. Protection Multiplier is 12 and is the number used to calculate the tree's protection radius and area
6. Protection Radius is a radial distance measured from the trunk centre.
7. Growth Vitality - Normal growth, Moderate (below normal), Poor (sparse/weak), Dead (dead or dying tree).
8. Structural Condition - Good (no or only minor defects), Fair (remediable defects), Poor - Major defects present.
9. Landscape Contribution - High (prominent landscape feature), Medium (visible in landscape), Low (secluded/among other trees).
10. B.S. Cat refers to (British Standard 5837:2012 section 4.5) and refers to tree/group quality and value; 'A' – High, 'B' - Moderate, 'C' - Low, 'U' - Unsuitable for retention. The following colouring has been used on the site plans:
 

█	High Quality (A) (Green),
█	Moderate Quality (B) (Blue),
█	Low Quality (C) (Grey),
█	Unsuitable for Retention (U) (Red)
11. Sub Cat refers to the retention criteria values where 1 is Arboricultural, 2 is Landscape and 3 is Cultural including Conservational, Historic and Commemorative.
12. Useful Life is the tree's estimated remaining contribution in years.

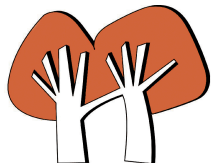

Landmark Trees

Site: Gospel Oak Primary, Mansfield Road, London NW3 2JB

Date: 24 10 2013

Landmark Trees Ltd

Tel: 020 7851 4544

Surveyor(s): Adam Hollis

Ref: NPS/GOP/AIA/01

## BS5837 Tree Constraints Survey Schedule

Tree No.	English Name	Height	Crown Spread	Ground Clearance	Clear Stem Height	Stem Diameter	Age Class	Protection Radius	Growth Vitality	Structural Condition	B.S. Cat	Sub Cat	Useful Life	Comments
1	Lime, Common	11	3	2.0	3.0	610.0	Mature	7.3	Normal	Fair	B	1	20-40	Pollarded with weak unions in new growth Cavity pockets in old pruning wounds
2	Cypress, Leyland	8	2332	1.5	0.5	210.0	Semi-mature	2.5	Normal	Fair	C	2	10-20	Poor form
3	Cherry, Ornamental	9	4132	2.0	2.0	150.0	Semi-mature	1.8	Moderate	Fair	C	2	20-40	Suppressed by nearby tree
4	Cherry, Ornamental	9	4131	2.0	3.0	130.0	Young	1.6	Moderate	Poor	U		<10	Grafted on to fence
H5	Beech, Common	8	2	0.0	0.5	80.0	Young	1.0	Moderate	Fair	C	2	>40	Suppressed by nearby tree
6	Lime, Common	10	3	2.0	2.5	310.0	Early Mature	3.7	Normal	Fair	B	1	20-40	Pollarded with weak unions in new growth Cavity pockets in old pruning wounds



Landmark Trees

Site: Gospel Oak Primary, Mansfield Road, London NW3 2JB

Date: 24 10 2013

Landmark Trees Ltd

Tel: 020 7851 4544

Surveyor(s): Adam Hollis

Ref: NPS/GOP/AIA/01

## BS5837 Tree Constraints Survey Schedule

Tree No.	English Name	Height	Crown Spread	Ground Clearance	Clear Stem Height	Stem Diameter	Age Class	Protection Radius	Growth Vitality	Structural Condition	B.S. Cat	Sub Cat	Useful Life	Comments
7	Lime, Common	7	2	2.0	3.0	140.0	Semi-mature	1.7	Normal	Good	C	2	>40	
8	Ash, Common	7	3131	3.0	3.0	100.0	Young	1.2	Moderate	Poor	U		<10	Grafted on to fence
9	Ash, Common	11	4334	3.0	3.5	240.0	Semi-mature	2.9	Normal	Fair	C	2	10-20	Co-dominant stems E stem removed Canopy still adjusting to loss of E stem. Minor deadwood
10	Elder	9	3232	3.0	1.0	171.5	Mature	2.1	Poor	Poor	U		<10	Dying back (inner crown) Honey fungus at base
11	Ash, Common	11	3443	4.0	3.0	220.0	Semi-mature	2.6	Normal	Fair	C	2	10-20	Deadwood (minor) throughout crown Canopy still adjusting to loss of T9's E stem
12	Cherry, Wild (Gean)	10	4	2.0	2.0	290.0	Early Mature	3.5	Normal	Fair	C	1	10-20	Break-out wound in main fork Decay in trunk / wound Bleed below wound



Landmark Trees

Site: Gospel Oak Primary, Mansfield Road, London NW3 2JB

Date: 24 10 2013

Landmark Trees Ltd

Tel: 020 7851 4544

Surveyor(s): Adam Hollis

Ref: NPS/GOP/AIA/01

## BS5837 Tree Constraints Survey Schedule

Tree No.	English Name	Height	Crown Spread	Ground Clearance	Clear Stem Height	Stem Diameter	Age Class	Protection Radius	Growth Vitality	Structural Condition	B.S. Cat	Sub Cat	Useful Life	Comments
13	Maple, Field	13	3545	2.5	2.0	380.0	Early Mature	4.6	Normal	Fair	B	2	>40	Ivy clad Long low lateral branch over play area SW
G14	Lime, Common	8	1.5	2.0	3.0	450.0	Early Mature	5.4	Normal	Fair	C	2	>40	Pollarded Decay in pollard heads Bases inaccessible, remote survey only.
15	Maple, Field	10	3435	2.0	1.0	326.5	Early Mature	3.9	Normal	Fair	B	2	>40	Co-dominant limbs Included bark in branch unions
16	Whitebeam, Swedish	8	2	2.0	2.0	180.0	Semi-mature	2.2	Normal	Good	C	1	20-40	A tree with insignificant defects
17	Lime, Common	8	3232	1.0	2.5	130.0	Semi-mature	1.6	Normal	Good	C	1	20-40	Co-dominant limbs Included bark in branch unions
18	Ash, Common	8	2321	1.0	1.5	86.0	Young	1.0	Normal	Fair	C	2	20-40	Self-sown / unsuitable location

## APPENDIX 2

### RECOMMENDED TREE WORKS

#### Notes for Guidance:

#### **Husbandry 1 - Urgent (ASAP), 2 - Standard (within 6 months), 3 - Non-urgent (2-3 years)**

- RP - Pre-emptive root pruning of foundation encroachments under arboricultural supervision.
- CB - Cut Back to boundary/clear from structure.
- CL# - Crown Lift to given height in meters.
- CT#% - Crown Thinning by identified %.
- CCL - Crown Clean (remove deadwood/crossing and hazardous branches and stubs).
- CR#% - Crown Reduce by given maximum % (of outermost branch & twig length)
- DWD - Remove deadwood.
- Fell - Fell to ground level.
- FInv - Further Investigation (generally with decay detection equipment).
- Pol - Pollard or re-pollard.
- Mon - Monitor ongoing condition (annually by staff / owners & every 2-3 yrs by consultant).
- Svr Ivy / ClrBs - Sever ivy / clear base and re-inspect base / stem for concealed defects.



Site: Gospel Oak Primary, Mansfield Road, London NW3 2JB

Date: 24 10 2013

Surveyor(s): Adam Hollis

Ref: NPS/GOP/AIA/01

Show All Trees

Hide irrelevant

## Recommended Tree Works

### Landmark Trees

Tree No.	English Name	Height	Stem Diameter	Crown Spread	Recommended Works	Comments/ Reasons
1	Lime, Common	11	610.0	3	FInv Further Investigation of cavity	Pollarded with weak unions in new growth Cavity pockets in old pruning wounds Recommended Husbandry 2
4	Cherry, Ornamental	9	130.0	4131	Fell	Grafted on to fence Recommended Husbandry 2
6	Lime, Common	10	310.0	3	FInv Further Investigation of cavity	Pollarded with weak unions in new growth Cavity pockets in old pruning wounds Recommended Husbandry 2
8	Ash, Common	7	100.0	3131	Fell	Grafted on to fence Recommended Husbandry 2
9	Ash, Common	11	240.0	4334	Mon	Co-dominant stems E stem removed Canopy still adjusting to loss of E stem. Minor deadwood Recommended Husbandry 3
10	Elder	9	171.5	3232	Fell	Dying back (inner crown) Honey fungus at base Recommended Husbandry 2
11	Ash, Common	11	220.0	3443	Mon	Deadwood (minor) throughout crown Canopy still adjusting to loss of T9's E stem Recommended Husbandry 3

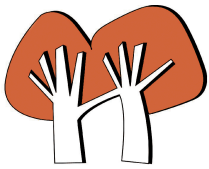

Site: Gospel Oak Primary, Mansfield Road, London NW3 2JB

Date: 24 10 2013

Surveyor(s): Adam Hollis

Ref: NPS/GOP/AIA/01

Show All Trees

Hide irrelevant

## Recommended Tree Works

### Landmark Trees

Tree No.	English Name	Height	Stem Diameter	Crown Spread	Recommended Works	Comments/ Reasons
12	Cherry, Wild (Gean)	10	290.0	4	Mon	Break-out wound in main fork Decay in trunk / wound Bleed below wound Recommended Husbandry 3
13	Maple, Field	13	380.0	3545	Svr Ivy CB CB lateral 1-2m	Ivy clad Long low lateral branch over play area SW Recommended Husbandry 3
G14	Lime, Common	8	450.0	1.5	RE Clear base to facilitate fuller inspection	Pollarded Decay in pollard heads Bases inaccessible, remote survey only. Recommended Husbandry 3
15	Maple, Field	10	326.5	3435	Mon Check seams of forks	Co-dominant limbs Included bark in branch unions

## APPENDIX 3

### RECOMMENDED TREE WORKS TO FACILITATE DEVELOPMENT (See Table 1)

#### Notes for Guidance:

- CB - Cut Back to boundary/clear from structure.
- CL# - Crown Lift to given height in meters.
- CT#% - Crown Thinning by identified %.
- CCL - Crown Clean (remove deadwood/crossing and hazardous branches and stubs).
- CR#% - Crown Reduce by given maximum % (of outermost branch & twig length)
- DWD - Remove deadwood.
- Fell - Fell to ground level.
- FInv - Further Investigation (generally with decay detection equipment).
- Pol - Pollard or re-pollard.
- Mon - Monitor ongoing condition (annually by staff / owners & every 2-3 yrs by consultant).
- Svr Ivy / ClrBs - Sever ivy / clear base and re-inspect base / stem for concealed defects.





Site: Gospel Oak Primary, Mansfield Road, London NW3 2JB

Surveyor(s): Adam Hollis

Date: 24 10 2013

Ref: NPS/GOP/AIA/01

# Tree Works for Development

Show All Trees

Hide irrelevant

## Landmark Trees

Tree No.	English Name	Height	Stem Diameter	Crown Spread	Recommended Works	Comments/ Reasons
2	Cypress, Leyland	8	210.0	2332	Fell	Poor form To Facilitate Development
3	Cherry, Ornamental	9	150.0	4132	Fell	Suppressed by nearby tree To Facilitate Development
9	Ash, Common	11	240.0	4334	Fell	Co-dominant stems E stem removed Canopy still adjusting to loss of E stem. Minor deadwood To Facilitate Development
11	Ash, Common	11	220.0	3443	Fell	Deadwood (minor) throughout crown Canopy still adjusting to loss of T9's E stem To Facilitate Development
16	Whitebeam, Swedish	8	180.0	2	Fell	A tree with insignificant defects To Facilitate Development
17	Lime, Common	8	130.0	3232	Fell	Co-dominant limbs Included bark in branch unions To Facilitate Development
18	Ash, Common	8	86.0	2321	Fell	Self-sown / unsuitable location To Facilitate Development

## APPENDIX 4: TREE SELECTION FOR CONSTRICTED LOCATIONS

Table 4: Rosaceous Tree Species for Constricted Planting Locations

Common Name	Species	Selected Form
Hawthorn	<i>Crataegusmonogyna</i>	Stricta
Cockspur	<i>Crataegusprunifolia</i>	Splendens
Cherry	<i>Prunus x hillieri</i>	Spire
Bird cherry	<i>Prunuspadus</i>	Albertii
Rowan / Mountain ash	<i>Sorbusaucuparia</i>	Cardinal Royal
Rowan / Mountain ash	<i>Sorbusaucuparia</i>	Rossica Major
Rowan / Mountain ash	<i>Sorbusaucuparia</i>	Sheerwater Seedling
Swedish whitebeam	<i>Sorbusintermedia</i>	Brouwers
B.whitebeam	<i>Sorbus x thuringiaca</i>	Fastigiata

Table 5: Specimen Tree Species for Constricted Planting Locations

Common Name	Species	Selected Form
Chinese red bark birch	<i>Betulaalbosinensis</i>	Fascination
Swedish birch	<i>Betulapendula</i>	Dalecarlica
Hornbeam	<i>Carpinusbetulus</i>	FastigiataFransFontaine
Turkish Hazel	<i>Coryluscolumna</i>	
Maidenhair tree	<i>Gingko biloba</i>	
Pride of India	<i>Koelreuteriapaniculata</i>	Fastigiata
European larch	<i>Larix decidua</i>	Sheerwater Seedling
Tulip tree	<i>Liriodendron tulipifera</i>	Fastigiata

**APPENDIX 5**

TREE CONSTRAINTS PLAN

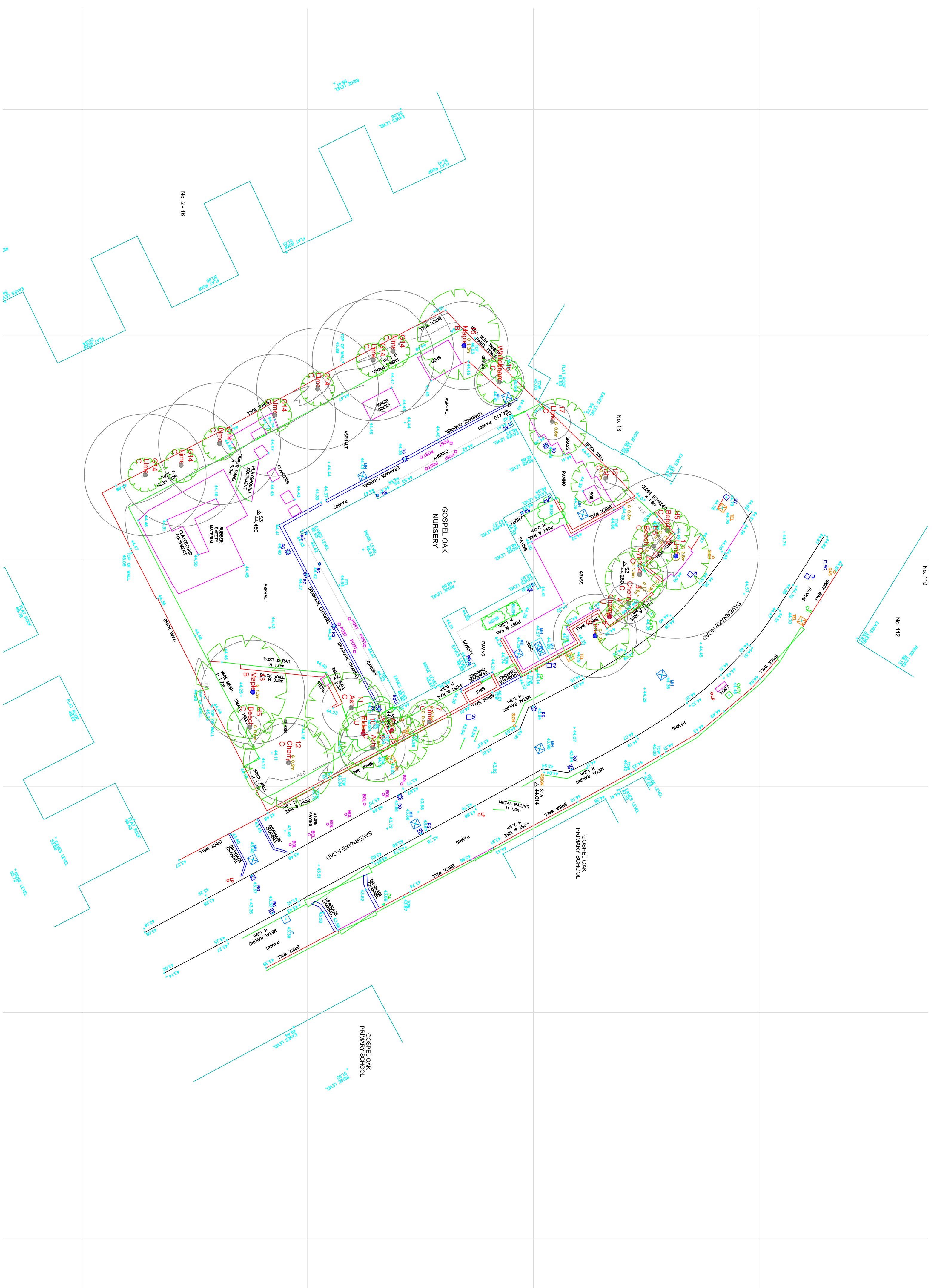

**NOTE:**  
 This survey is of a preliminary nature. The trees were inspected from the ground only analysis. No decay detection equipment was employed. The survey does not cover the arrangements that may be required in connection with the felling or removal of underground services.  
 Branch spread in plan is taken at the four cardinal points to derive an accurate representation of the crown.  
 Root Protection Areas (RPA) are derived from stem diameter measured at 1.5 m above adjacent ground level (taken on sloping ground on the upslope side of the tree base).

**Landmark Trees**  
 20 Broadwick Street, London, W1F 8HT  
 Tel: 0207 639 4544 Mobile: 07812 869828  
 Landmark\_Trees  
 Email: info@landmarktrees.co.uk Web: www.landmarktrees.co.uk

Client: Gospel Oak Primary  
 Drawing Title: Tree Constraints Plan  
 1:200 @ A1  
 October 2013

**Key:**

● High Quality	○ Category A	○ Crown Spread
● Medium Quality	○ Root Protection Area	○ Tree Number
● Low Quality	○ Species	○ Category
● Category U	○ Tree Position Approximate (not shown on original survey)	
○ Trees Unsuitable for Retention		

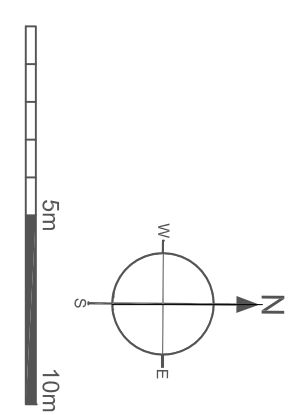

**APPENDIX 6**

ARBORICULTURAL IMPACT ASSESSMENT PLAN





**NOTE:**  
 This survey is of a preliminary nature. The trees were inspected from the ground only on the basis of the Visual Tree Assessment method. No samples were taken for analysis. No decay detection equipment was employed. The survey does not cover the arrangements that may be required in connection with the laying or removal of underground services.  
 Branch spread in metres is taken at the four cardinal points to derive an accurate representation of the crown.  
 Root Protection Areas (RPA) are derived from stem diameter measured at 1.5 m above adjacent ground level (taken on sloping ground on the upslope side of the tree base).

**Landmark Trees**  
 20 Broadwick Street, London, W1F 8HT  
 Tel: 0207 851 4544 Mobile: 07812 989528  
 e-mail: info@landmarktrees.co.uk Web: www.landmarktrees.co.uk

Site: Gospel Oak Primary  
 Drawing Title: Arboricultural Impact Assessment Plan  
 1:200@A1  
 October 2013

**Key:**

- Category A High Quality
- Category B Moderate Quality
- Category C Low Quality
- Category U Trees Unsuitable for Retention

Category — Crown Spread  
 Tree Number  
 Species  
 Category  
 Root Protection Area  
 Tree Position Approximate (not shown on original survey)

