

This drawing has been prepared for Planning purposes only and should not be used for construction purposes.

All dimensions are in millimetres unless stated otherwise

Specific key and notes

- 1 External Space with planting to provide privacy and prevent overlooking
- 2 Glass balustrade set back inside the parapet
- 3 Living area
- 4 Kitchen dining area
- 5 Smoke vent to stair
- 6 Chimney No. 4 Emerald Street
- 7 PV panels

Key Plan

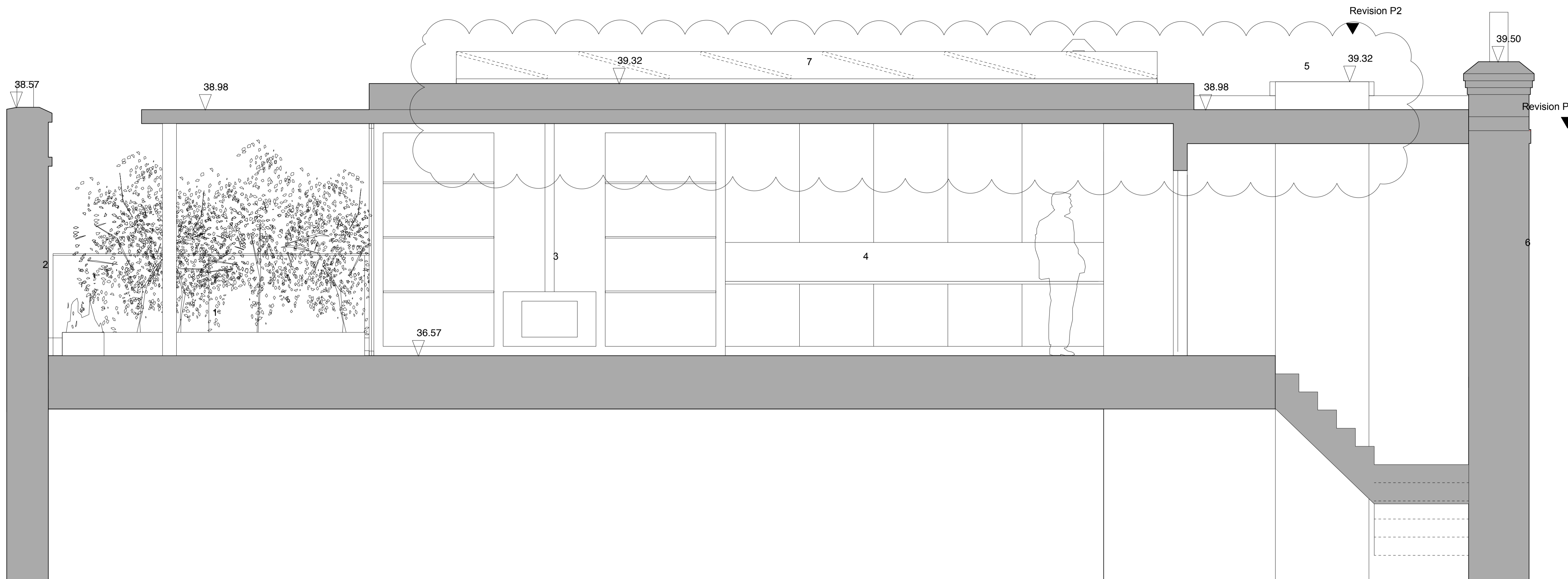
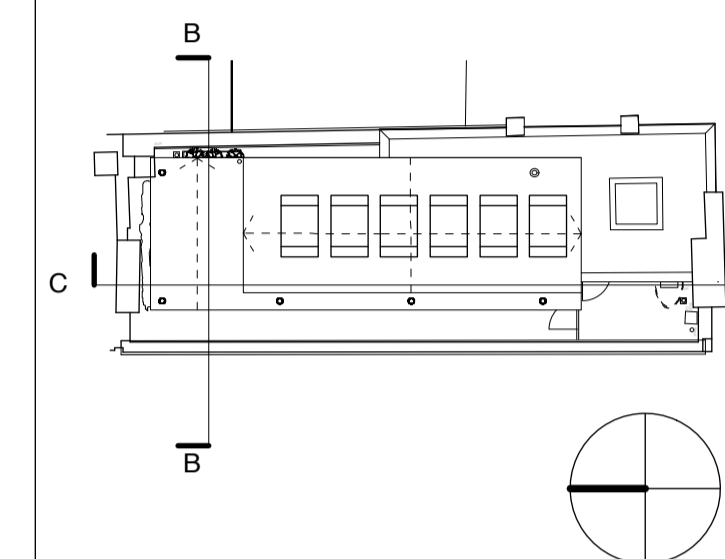

Long Section CC
As Proposed

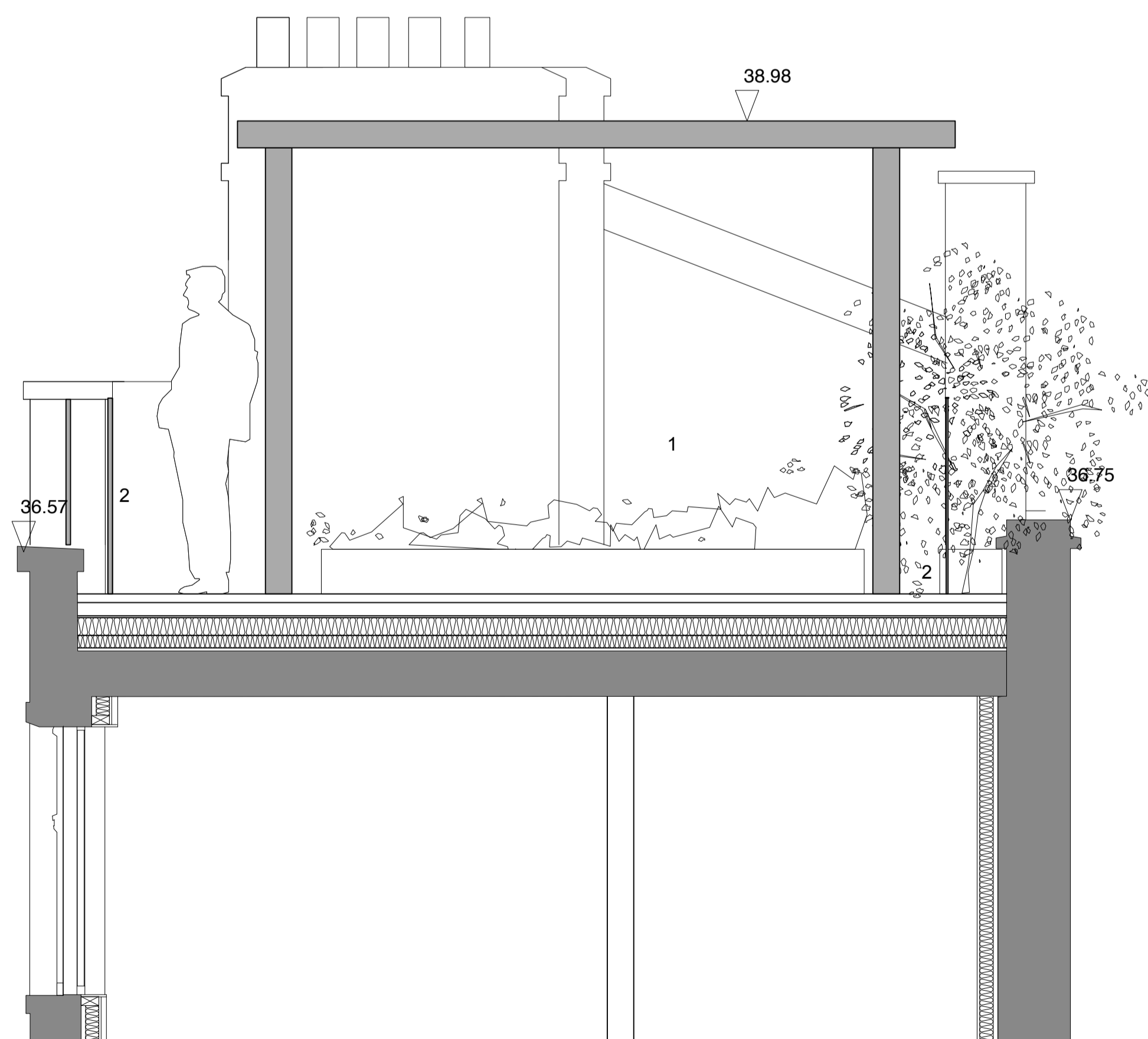

Section DD
Cross section of external space
As Proposed

P2	Planning	- PV panels added - Smoke vent added	AK	13/12/13
P1	Planning		HB	07/07/11

Mayfair & Holland Properties Limited
6-8 Emerald Street
 Proposed Section CC & BB
 As Proposed
 Status: Planning
 Scale: 1:25
 January 2014

Draw N° 180/GA05	Rev P2
Drawn by HF	Authorised by AK
	Size A1

HUGHBROUGHTONARCHITECTS

41a Beavor Lane London W6 9BL
 T 020 8735 9959 F 020 8563 3891 E info@hbarchitects.co.uk
 © Hugh Broughton Architects Ltd