

This drawing has been prepared for Planning purposes only and should not be used for construction purposes.

All dimensions are in millimetres unless stated otherwise

Specific key and notes

- 1 Commercial unit
- 2 Residential unit
- 3 Proposed planting to prevent overlooking
- 4 External Space

Key Plan

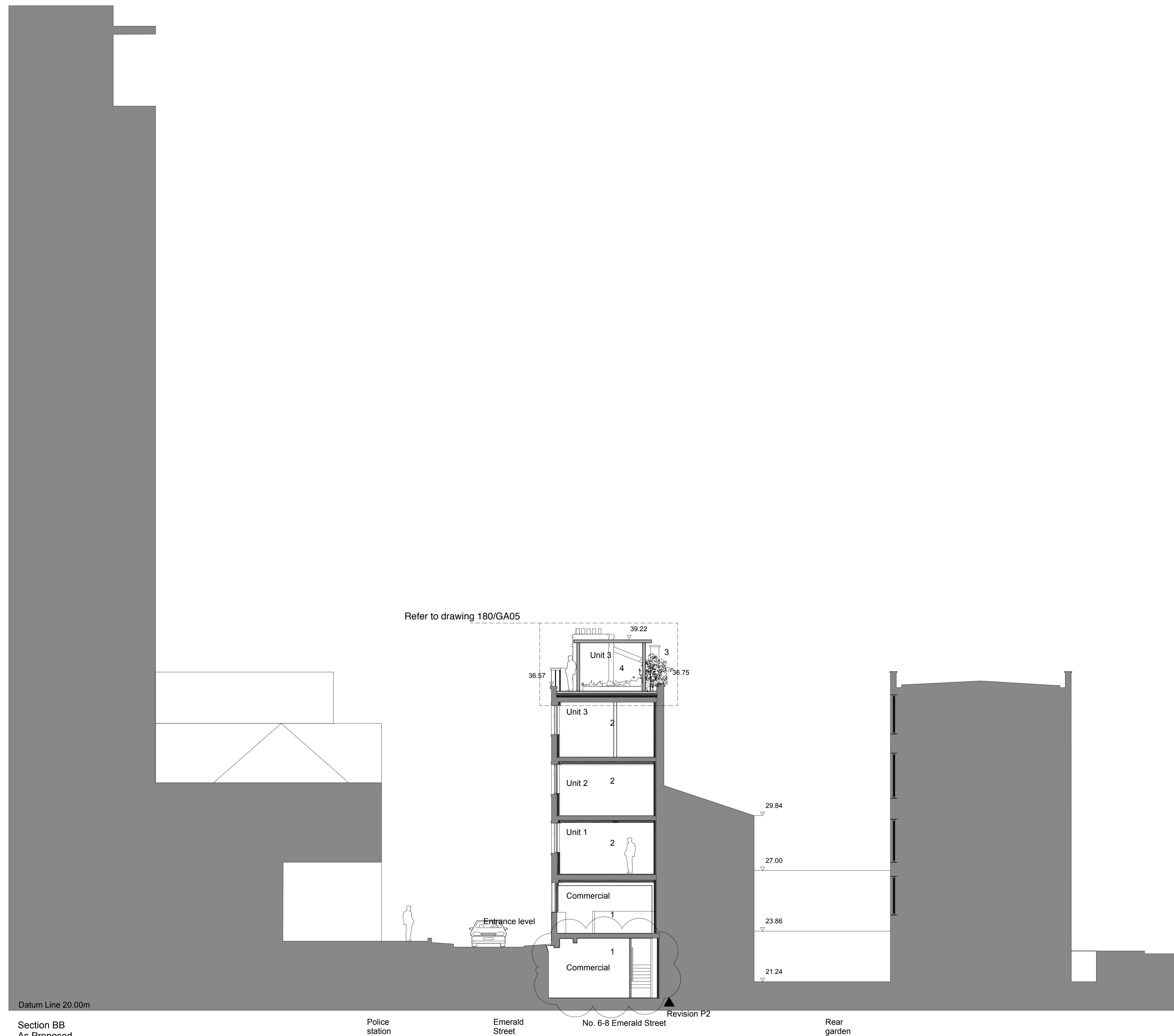
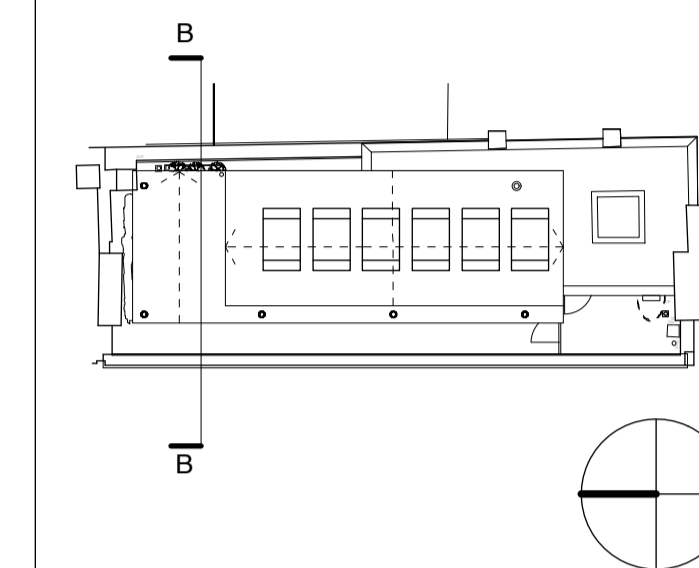

P2 Planning - Amendment to stair to basement AK 13/12/13

P1 Planning HB 07/07/11

Mayfair & Holland Properties Limited
6-8 Emerald Street
 Proposed Section BB
 As Proposed
 Status: Planning
 Scale: 1:100
 January 2014

Draw N° 180/GA04 Rev P2

Drawn by HF Authorised by AK Size A1

HUGHBROUGHTONARCHITECTS

41a Beavor Lane London W6 9BL
 T 020 8735 9959 F 020 8563 3891 E info@hbarchitects.co.uk
 © Hugh Broughton Architects Ltd