

Camden Planning Guidance

# Housing

London Borough of Camden

CPG 2



## CPG1 Housing

1	Introduction .....	5
2	Affordable housing and housing in mixed use development....	7
3	Student Housing.....	39
4	Residential development standards .....	51
5	Lifetime Homes and Wheelchair Housing .....	61

**Index**

Affordable housing .....	7	Outdoor amenity space .....	59
Affordable housing (off site) .....	27	Privacy (residential standards) ....	57
Basements (residential standards) .....	57	Residential development standards .....	51
Daylight (residential standards)...	56	Room sizes .....	54
Dwelling sizes (mix of).....	20	Sliding scale (affordable housing)	13
Habinteg .....	67	Soundproofing (residential standards).....	58
HomeBuy.....	19	Space standards (internal) .....	53
Housing costs.....	10	Student Housing .....	39
Housing mix (social to intermediate) .....	17	Viability (affordable housing) .....	23
Lifetime homes .....	62	Wheelchair housing .....	66

# 1 Introduction

## What is Camden Planning Guidance?

- 1.1 We have prepared this Camden Planning Guidance (CPG) to support the policies in our Local Development Framework (LDF). This guidance is therefore consistent with the Core Strategy and the Development Policies, and forms a Supplementary Planning Document (SPD) which is an additional “material consideration” in planning decisions. This new guidance will replace the Camden Planning Guidance 2006, updating advice where appropriate and providing new guidance on matters introduced or strengthened in the LDF.
- 1.2 The Camden Planning Guidance covers a range of topics (such as design, sustainability, amenity and planning obligations) and so all of the sections should be read in conjunction, and within the context of Camden’s LDF.

## Housing in Camden

- 1.3 A key priority for the Council is to ensure that everyone has the opportunity to live in a decent home at a price they can afford in a community where they want to live. Camden is a very popular place to live, which means that average house prices are high and that the demand for affordable housing far outstrips supply.
- 1.4 In line with the London Plan, Camden has a target of 5,950 additional dwellings from 2007 to 2017 (an annual monitoring target of 595 additional homes).
- 1.5 The Local Development Framework seeks to make full use of Camden’s capacity for housing to establish a plentiful supply and broad range of homes. In addition to meeting or exceeding Camden’s housing targets, the Local Development Framework seeks to ensure that new homes are built to a high standard and provide well-designed accommodation that meets the needs of a range of occupiers.

### **What does this guidance cover?**

- 1.6 This guidance provides information on all types of housing development within the borough. It provides specific guidance on:
1. Affordable housing
  2. Student housing
  3. Residential Space standards
  4. Lifetime homes and wheelchair housing
- 1.7 It highlights the Council's requirements and guidelines which support the Local Development Framework policies:
- CS1 – Distribution of growth
  - CS5 – Managing the impact of growth and development
  - CS6 – Providing quality homes
  - CS14 – Promoting high quality places and conserving our heritage
  - DP1 – Mixed use development
  - DP2 – Making full use of Camden's capacity for housing
  - DP3 – Contributions to the supply of affordable housing
  - DP4 – Minimising the loss of affordable housing
  - DP5 – Homes of different sizes
  - DP6 – Lifetime homes and wheelchair housing
  - DP7 – Sheltered housing and care homes for older people
  - DP8 – Accommodation for homeless people and vulnerable people
  - DP9 – Student housing, bedsits and other housing with shared facilities
  - DP26 – Managing the impact of development on occupiers and neighbours

## 2 Affordable housing and housing in mixed use development

### KEY MESSAGES

- Affordable housing includes social rented housing and intermediate affordable housing
- Residential and mixed-use development adding 1,000 sq m gross housing or more should provide affordable housing
- Most mixed-use developments with residential floorspace should provide 50% affordable housing
- Residential developments should provide a proportion of affordable housing depending on their capacity for homes, taking into account proposed floorspace and number of dwellings
- Residential developments with capacity for 50 or more homes should provide 50% affordable housing
- Affordable housing should include a large proportion of family homes and contribute to creating mixed and inclusive communities
- Affordable housing should generally be provided on site

- 2.1 The guidance on affordable housing relates to Core Strategy policy CS6 - *Providing quality homes*, and Development Policies DP3 – *Contributions to the supply of affordable housing*, DP4 – *Minimising the loss of affordable homes*, and DP5 – *Homes of different sizes*. The guidance on housing in mixed-use development relates to Core Strategy policy CS1 – *Distribution of growth* and Development Policy DP1 – *Mixed-use development*.
- 2.2 The guidance is divided into seven subsections. Each subsection deals with a different question relating to requirements for affordable housing and housing in mixed-use development as follows:
- what is affordable housing?
  - which developments should contribute to affordable housing?
  - how much affordable housing do we expect?
  - what types of affordable housing do we expect?
  - how is affordable housing funded?
  - how the Council will consider financial viability?
  - can the market housing and affordable housing be provided off-site?
- 2.3 The property market, development finance and affordable housing funding have all been subject to considerable change since 2007, and it is likely that change will continue.
- 2.4 The implementation of planning policy will need to respond to these changes. Implementation guidance therefore needs to be more readily

reviewed and amended than would be possible within the Core Strategy or Development Policies.

- 2.5 The Government has announced changes to affordable housing funding, changes to affordable housing tenancies, and changes to the benefits system. Details of how these changes will operate are still emerging, but they are likely to have far-reaching effects on the potential to develop affordable housing in Camden that provides for the households that need it most. This guidance will therefore be subject to early review, and should be regarded as interim guidance until it has been amended to take full account of the Government's reforms.

### **When does this guidance apply?**

- 2.6 This guidance applies primarily to development that:
- provides an additional 1,000 sq m or more (gross) of housing in Use Class C3 or Use Class C4, or
  - provides an addition of 200 sq m or more (gross) of non-residential floorspace in the Central London Area (excluding Hatton Garden) or the town centres of Camden Road, Finchley Road/ Swiss Cottage and Kilburn High Road, or
  - provides affordable housing floorspace, or
  - involves the loss and replacement of affordable housing floor space.
- 2.7 We strongly encourage developers to involve a housing association or other affordable housing provider in the design of proposed affordable homes before submitting a planning application. Affordable housing development that is not purpose-designed is less likely to receive public funding and less likely to be sold or let to an affordable housing provider.

#### **HOUSING ASSOCIATIONS AND REGISTERED PROVIDERS**

In this guidance, the term housing associations is used to include all Registered Providers of affordable housing. Registered Providers are owners and managers of affordable housing who are regulated by Government. Many operate on a not-for-profit basis and use any trading surplus to maintain existing homes and to help finance new ones. Other Registered Providers include housing trusts and cooperatives.

- 2.8 A developer considering the appropriate use or mix of uses for a site should contact the Council's Regeneration and Planning Division in the first instance. The Strategic Planning and Information Team can provide initial guidance on the interpretation of policies in the Core Strategy and Development Policies document.
- 2.9 A formal pre-planning application advice service is available for development proposals. A fee is charged for this service on the basis of the size of the proposed development. We strongly encourage developers to use this service if they are proposing development of the type described in paragraph 2.6 of this guidance.

- 2.10 Where we are seeking affordable housing the developer should contact the Housing Partnerships Team. This team will provide guidance on the types of affordable housing that the Council is currently prioritising and suggest potential housing association partners that would be appropriate for the scheme. Paragraphs 2.55 and 2.56 of this guidance give more details of the Council's arrangements with housing associations.

## **Guidance**

### **What is affordable housing?**

- 2.11 Affordable housing is defined in the Government's Planning Policy Statement PPS3 – Housing (Annex B). PPS3 indicates that affordable housing should:
- meet the needs of households whose needs are not met by the market and who are eligible for affordable housing, and
  - be provided at a cost they can afford, taking into account local household incomes and market housing costs, and
  - be affordable to future households unless arrangements are in place for subsidies to be recycled into alternative affordable housing provision.
- 2.12 The London Plan provides details of income groups that are eligible for affordable housing, which the Mayor reviews annually.
- 2.13 Two types of affordable housing are defined in PPS3 – these are **social rented housing** and **intermediate affordable housing**. The Government intends to introduce a third type known as **affordable rented housing**.
- 2.14 **Social rented housing** is primarily housing managed by local councils and housing associations. The cost of social rented housing is controlled by a national rent regime. Other affordable housing providers may manage social rented housing under the same rental arrangements. Figure 1 provides information on the level of social rents and market rents in Camden.



**Figure 1. Housing costs in Camden 2008**

	1 bedroom	2 bedroom	3 bedroom	4 bedroom
social rented housing costs (per week)	£70	£82	£91	£101
market housing costs to rent (per week)	£240	£330	£450	£575
market housing price to buy	£275,000	£330,000	£425,000	£675,000

Source: Camden Housing Needs Survey Update 2008

(note – market costs given are for lower quartile rents in the cheaper areas of the borough – in these areas, 25% of market rents/ prices are lower than the figure given and 75% of market rents/ prices are higher)

- 2.15 **Intermediate affordable housing** is housing that costs more than social housing but less than equivalent market housing. Intermediate affordable housing costs (including service charges) must also be cheap enough for eligible income groups to afford. The London Plan and the Mayor's annual reviews provide details of eligible income groups. Most intermediate affordable housing in Camden has been provided by housing associations, but PPS3 indicates that intermediate affordable housing can include homes provided by private sector bodies. Provided that it costs less than market housing and is cheap enough for eligible income groups, intermediate affordable housing can include a range of tenures such as:
- rented housing;
  - shared-ownership housing (where occupiers buy a share and rent the remainder) and;
  - low cost homes for sale.
- 2.16 Camden controls the cost of intermediate affordable housing taking into account market costs and the eligible income groups set out in the London Plan and the Mayor's annual reviews. The Mayor's February 2011 review indicated that eligible households were those with incomes of less than £64,000 per year (gross). The draft replacement London Plan indicates that he intends to raise the eligible income to £74,000 per year for intermediate affordable homes with 2-bedrooms or more.
- 2.17 To convert income thresholds into housing costs, the Mayor's Housing Supplementary Planning Guidance (2005) indicates that intermediate affordable housing should cost:
- no more than 3.5 times the household income threshold to buy; and
  - no more than 40% of net household income including rent and service charges.
- 2.18 Camden's Core Strategy recognises that intermediate affordable housing needs to be attractive to a range of household types across a

range of incomes. More guidance is provided on how we seek a range of intermediate affordable housing in the sub-section 'What types of affordable housing do we expect?'

- 2.19 **Affordable rented housing** is a new product devised by the Government. The Government intends this to meet the general PPS3 definition of affordable housing summarised in paragraph 2.11, but to be outside the national rent regime. Rents should not exceed 80% of local market rents. In March 2011 only limited information has been released on rent control mechanisms, and the Council has yet to consider its approach to affordable rented housing. The cost of market housing in Camden is very high compared with the incomes of those who are in need and are eligible for affordable housing. Initial indications are that the potential for affordable rented housing to meet housing need in Camden is extremely limited, particularly need for affordable family homes. This guidance will be reviewed when the potential contribution of affordable rented housing is understood more clearly.

### **Which developments should contribute to affordable housing?**

- 2.20 Camden's Development Policies document indicates that the Council will expect all residential developments with capacity for 10 or more additional dwellings to make a contribution to the supply of affordable housing. This also applies to mixed-use developments that include housing and have capacity for 10 or more dwellings in addition to any appropriate non-residential floorspace.
- 2.21 Camden's Development Policies document also indicates that an additional floorspace of 1,000 sq m (gross) is capable of accommodating 10 dwellings, and any development adding residential floorspace of 1,000 sq m (gross) or more should make a contribution to the supply of affordable housing.
- 2.22 A contribution to affordable housing is expected from schemes that add fewer than 10 dwellings but add more than 1,000 sq m floorspace (gross) on the basis that economic viability can still be achieved from a small number of larger and more expensive homes. A contribution will also be sought from schemes that add 10 or more dwellings but add less than 1,000 sq m floorspace (gross) unless the applicant demonstrates it would not be financially viable to proceed with the development on that basis (see the sub-section How will the Council consider financial viability?).
- 2.23 We acknowledge that an addition of 1,000 sq m residential floorspace will not have a 10 dwelling capacity in every single case. In assessing capacity, the Council will take into account whether the additional area is capable of forming habitable space. We will also take into account any other constraints that would prevent 10 dwellings from being developed, such as where it would be impractical to provide safe vehicle access for 10 dwellings, or inappropriate to subdivide a Listed Building.

2.24 Under Development Policy DP1, the Council requires mixed-use developments to include housing where appropriate. Paragraphs 1.19 to 1.24 of the Development Policies document provide more guidance on how the Council will consider whether a contribution to the supply of housing is appropriate. In the Central London Area (except Hatton Garden) and the larger town centres of Camden Town, Finchley Road/Swiss Cottage and Kilburn High Road, where development proposals add 200 sq m (gross) floorspace or more, policy DP1 requires up to 50% of additional floorspace to be housing. This requirement combines with the affordable housing requirements of policy DP3 so that in the Central London Area and the larger town centres, where developments add 2,000 sq m (gross) floorspace or more:

- the Council will generally seek 1,000 sq m or more of additional housing;
- the development will generally have capacity for 10 or more additional homes, and we will expect a contribution to the supply of affordable housing.

2.25 The floorspace thresholds in Development Policy DP1 refer to additions to gross floorspace (assessed in terms of Gross External Area – GEA). The policy requirements are not triggered by increases in net non-residential floor space that take place wholly within the existing building envelope, such as reduction in circulation space, common areas or plant areas, or inserting a mezzanine floor. However, works involving a change to residential use will trigger policy DP3 affordable housing requirements if the residential floorspace has capacity for 10 or more additional homes.

**GROSS EXTERNAL AREA/ GROSS EXTERNAL FLOORSPACE**

The whole area of a building taking each floor into account. Includes the thickness of external walls, partition walls and common areas such as shared staircases, entrance halls and corridors.

**GROSS INTERNAL AREA/ GROSS INTERNAL FLOORSPACE**

The whole enclosed area of a building within the external walls taking each floor into account and excluding the thickness of the external walls. Includes the thickness of partition walls and common areas such as shared staircases, entrance halls and corridors.

**NET INTERNAL AREA/ NET INTERNAL FLOORSPACE**

The usable area within a building measured to the face of perimeter or party walls. Includes the thickness of internal partition walls, but excludes common areas and the thickness of partition walls that define the edge of common areas.

2.26 As indicated in the Development Policies document, the approach to affordable housing set out in policy DP3 and in this guidance is suitable for housing that is self-contained, including self-contained sheltered housing for older people (i.e. homes in Use Class C3). The approach will also apply if additional floorspace is proposed in Use Class C4 (small houses in multiple occupation) as these can be used as self-contained C3 homes without submitting a planning application.

- 2.27 This approach to affordable housing is not suitable for housing with shared facilities, such as student housing and bedsits. A contribution to affordable housing is not generally expected from developments of student housing and other housing with shared facilities provided that it complies with Development Policy DP9 and contributes to creating a mixed and inclusive community. However, the Council will seek to ensure that student housing is attractive to groups who would otherwise share private rented homes, and in some circumstances will seek self-contained general needs housing on part of the site, including affordable housing. A separate section of our planning guidance gives more information about development of **Student Housing**.
- 2.28 The Council may need to consider controlling the affordability of care homes for older people and accommodation for homeless people or vulnerable people. Some aspects of this guidance will not be suitable for these types of housing, and the Council will tailor its approach as appropriate to fit the specific type of occupier and provider.

### **How much affordable housing do we expect?**

- 2.29 Our Core Strategy and Development Policies give targets and criteria which we use to assess the appropriate contribution to affordable housing from each development. These include:
- an overall borough target equivalent to 220 additional affordable homes per year;
  - seeking to achieve the maximum reasonable amount of affordable housing under the specific circumstances of the site, including the financial viability of the development;
  - aiming to minimise social polarisation and create mixed and inclusive communities;
  - an affordable housing target for specific developments of 50% of additional residential floorspace; and
  - a sliding scale setting lower affordable housing targets for developments that have capacity for 10 to 49 additional homes.
- 2.30 The sliding scale is explained in paragraphs 3.17 to 3.20 of our Development Policies document. The purpose of the sliding scale is to encourage developers to cross the 10-dwelling threshold and propose medium-sized schemes rather than small schemes. In this way the sliding scale has potential to add significantly to the number of schemes that deliver affordable housing, and the overall amount of affordable housing. Paragraph 3.21 of the Development Policies document indicates that we will monitor the operation of the sliding scale closely to assess its impact on the supply of housing, and consider any need to review the approach through our Annual Monitoring Report.
- 2.31 The sliding scale is a simple straight-line scale, where every increase of 1 home in site capacity should provide an additional 1% in affordable housing floorspace. Sites with capacity for 10 additional homes should normally provide 10% affordable housing floorspace, sites with capacity

for 20 additional homes should normally provide 20% affordable housing floorspace, and sites with capacity for 40 additional homes should normally provide 40% additional floorspace. Figure 2 below indicates how the sliding scale will operate in more detail.

- 2.32 When we assess capacity, we will look at the number of additional homes proposed and the additional built floorspace (gross). As a minimum, an acceptable development has capacity for the number of additional homes proposed. In terms of floorspace, 1,000 sq m (gross) of built development is considered to have capacity for 10 dwellings. Each additional 100 sq m (gross) added to the development is considered to create capacity for an additional dwelling (including capacity for a share of common areas such as shared staircases, entrance halls and corridors). We will round floorspace to the nearest 100 sq m to give capacity in terms of the nearest whole number. In negotiations we will focus on seeking affordable homes of an appropriate size and layout rather than absolute mathematical correspondence with the sliding scale.

**Figure 2. Sliding scale for affordable housing negotiations**

<b>Benchmark</b>	<b>Site capacity</b>	<b>Expected affordable housing floorspace</b>
10 homes proposed, or fewer homes with a floorspace of 1,000 sq m gross	10 homes	10%
20 homes proposed, or fewer homes with a floorspace of 2,000 sq m gross	20 homes	20%
30 homes proposed, or fewer homes with a floorspace of 3,000 sq m gross	30 homes	30%
40 homes proposed, or fewer homes with a floorspace of 4,000 sq m gross	40 homes	40%
50 homes or more proposed, or fewer homes with a floorspace of 5,000 sq m gross or more	50 homes or more	50%
<b>Example</b>	<b>Site capacity</b>	<b>Expected affordable housing floorspace</b>
21 homes with a built floorspace of 1,735 sq m gross	21 homes	21% x 1,735 sq m
22 homes with a built floorspace of 2,360 sq m gross	24 homes	24% x 2,360 sq m
35 homes with a built floorspace of 3,749 sq m gross	37 homes	37% x 3,749 sq m
46 homes with a built floorspace of 4,280 sq m gross	46 homes	46% x 4,280 sq m

2.33 As indicated in paragraphs 1.12 and 3.18 of our Development Policies document, the sliding scale will only apply to mixed use developments that include housing in limited circumstances.

- The sliding scale will apply if the development adds less than 1,000 sq m to non-residential floorspace but has a residential element with capacity for an additional 10 to 49 homes (i.e. 1,000sq m to 4,900sq m residential floor space).
- The sliding scale will not apply if the development includes an addition to non-residential floorspace of 1,000 sq m or more. In this case there is significant potential for the non-residential element to enhance the viability of the development, and we will seek 50% of residential floorspace as affordable housing (subject to DP3 criteria).
- In all mixed-use schemes with capacity for 50 or more additional homes we will seek 50% of residential floorspace as affordable housing (subject to DP3 criteria).

- 2.34 When negotiating on individual schemes, Camden calculates the proportion of housing in each category (market/ social rented/ intermediate affordable) in terms of floorspace. This arrangement enables us to negotiate family-sized affordable housing in schemes where the developer proposes smaller market homes, and prevents an under-provision of affordable housing where the developer proposes unusually large market homes. Calculations will not generally be based on the number of dwellings or number of habitable rooms as these calculations would create an incentive for the developer to provide the smallest affordable homes possible.
- 2.35 Calculations of the capacity of the site are based on gross floorspace, including common areas. However, it is generally more appropriate to consider net internal floorspace when considering the split between market, social rented and intermediate affordable housing. This allows the homes themselves to be compared without the distortion of shared spaces such as external corridors and lobbies, lifts and common staircases. See paragraph 2.25 of this guidance for more detailed definitions of gross and net floorspace.
- 2.36 Policy CS6 of our Core Strategy and Development Policy DP3 indicate that the Council will consider many other characteristics of the development, the site and the area when negotiating the proportion of affordable housing in specific schemes. These considerations are explained in detail in paragraphs 3.24 to 3.29 of our Development Policies document. Considerations include seeking a mixture of tenures in each part of the borough, having regard to any social problems arising from existing concentrations of a single tenure, and other planning objectives considered to be a priority for the site. As part of estate regeneration we will seek to improve the tenure mix in some areas of concentrated social rented housing, such as parts of Gospel Oak.
- 2.37 Where we agree that the affordable housing can be provided off-site, the amount of affordable housing sought will be adjusted. These adjustments are explained in the sub-section 'Can the market housing and affordable housing be provided off-site?'
- 2.38 The Camden Affordable Housing Viability Study 2009 examined the viability of the sliding scale and the 50% floorspace target for sites with capacity for 50 homes or more. The Study indicates that the scale and target is financially viable for a range of scheme types across a range of locations in the borough. However, there will be circumstances where the percentage of affordable housing sought by the sliding scale or target is not viable. The sub-section '**How will the Council consider financial viability?**' explains what we will expect from the developer in these circumstances.

## What types of affordable housing do we expect?

### Mixing affordable housing and market housing

- 2.39 The Council expects affordable housing and market housing to form integral parts of each development. A common design approach should be used, with high quality materials and finishes throughout. Where a development site is large enough to accommodate several residential blocks, market and affordable blocks should be spread evenly across the site. The layout of the development should optimise residential amenity for all tenures, and avoid concentrating affordable housing close to potential sources of disturbance such as service yards, traffic and railways.
- 2.40 As indicated in paragraph 3.26 of our Development Policies document, in schemes with internal communal spaces, the Council does not seek to mix affordable and market dwellings on the same corridors or sharing the same stairs, lifts and entrance lobbies. This is because occupiers have to pay a service charge and/ or management charge for the cleaning and maintenance of communal spaces, and the law requires that occupiers receiving the same common services should pay the same service charge regardless of tenure. Service charges are often a significant proportion of overall housing costs, and can simply be too high for the occupiers of affordable housing to pay. To ensure that service charges are kept to a minimum, the communal parts of affordable housing are generally designed for durability and low maintenance costs.

#### SERVICE CHARGES

A contribution towards the cost of repairs to the building, and maintenance of communal areas.

- 2.41 Paragraph 3.14 of the Development Policies document notes that the Council may consider an off-site contribution to affordable housing if the service or management charges of an on-site scheme would be too expensive for affordable housing occupiers or providers. This is only likely to arise where the development is too small to provide separate entrances and staircases for the market housing and affordable housing - see the sub-section of this guidance '**Can the affordable housing be provided off-site?**'

### Mix of social rented housing and intermediate affordable housing

- 2.42 The Core Strategy indicates that we are aiming to tackle social polarisation and create mixed and balanced communities by seeking a diverse range of housing products to suit a range of incomes. Many households who need affordable homes in Camden will only be able to afford social rented housing, however we recognise that intermediate affordable housing can make an important contribution to creating mixed-communities. Camden's Core Strategy sets out guidelines that 60% of affordable housing should be social rented housing and 40% should be intermediate affordable housing. As indicated in paragraphs



2.34 and 2.35 of this guidance, it will generally be appropriate to calculate the split between social rented and intermediate affordable housing in terms of net internal floorspace.

- 2.43 Since adoption of Camden's Core Strategy and Development Policies document, the Government has introduced a new product called **affordable rented housing**. More information about affordable rented housing is provided in paragraph 2.19 of this guidance. Initial indications are that the potential for affordable rented housing to meet housing need in Camden is extremely limited, although small affordable rented homes may be able to help tackle social polarisation. The Council has yet to consider its approach to affordable rented housing, and this guidance will be reviewed when the potential contribution of affordable rented housing is understood more clearly. In the interim, proposals for affordable rented housing should be accompanied by a demonstration that the homes will comply with the Government's definition of affordable housing (as summarised in paragraph 2.11 of this guidance), and will be affordable to households whose needs are not met by market housing, having regard to lower quartile market rents available locally and across the borough. The Council is unlikely to support proposals for affordable rented homes that would be more expensive than market homes available anywhere in the borough.
- 2.44 Paragraph 6.57 of Camden's Core Strategy and Development Policy DP3 indicate that the Council will consider various characteristics of the development, the site and the area when negotiating the nature of the affordable housing contribution from specific schemes. Considerations that may influence the proportion of social rented housing and intermediate affordable housing are set out in paragraphs 3.22 to 3.30 of our Development Policies document. Circumstances where the Council may depart from the 60% social rented: 40% intermediate affordable split include:
- providing flexibility for up to 100% social rented housing or 100% intermediate affordable housing where the overall proportion of affordable housing in the scheme is substantially over 50%;
  - seeking up to 100% social rented housing where the overall proportion of affordable housing in the scheme is 30% or less;
  - providing flexibility for more than 40% intermediate affordable housing where this can help to create a mixed and inclusive community in an area with an existing concentration of social rented housing; and
  - providing flexibility for more than 60% social rented housing where high residential land values will make intermediate affordable housing too expensive for the households that need it.
- 2.45 A number of intermediate affordable housing types have been devised by the Government (most are currently marketed as HomeBuy). Camden seeks a variety of intermediate affordable housing to suit different needs, and will generally support intermediate rented housing, shared-ownership housing (where occupiers buy a share and rent the remainder) and models where occupiers can switch from rent to shared-

ownership. However, all intermediate affordable housing must comply with the cost requirements imposed by the Government and Mayor as indicated in paragraphs 2.15 to 2.17 of this guidance. When costs are assessed, service charges are included, and we will encourage developers to take this into account at the design stage so that service charges are minimised.

#### HOMEBUY

HomeBuy is a government-backed scheme providing affordable home ownership. It is available to tenants in social rented housing, people on the waiting list, key workers, and first-time buyers with a limited income.

- 2.46 We are particularly keen to promote take up of intermediate affordable housing by tenants of social rented housing. On the basis of the household incomes of those registering an interest in intermediate affordable housing, Camden will seek to achieve a proportion of the following:
- intermediate affordable rented homes that households can afford with an income of £30,000 or less per year (gross);
  - one-bedroom shared-ownership homes that households can afford with an income of £30,000 or less per year (gross);
  - two-bedroom shared-ownership homes that households can afford with an income of £40,000 or less per year (gross).
- 2.47 In negotiations on intermediate affordable housing and legal agreements, the Council will seek to ensure that homes are occupied by households in need of affordable housing, particularly tenants of existing social housing, and do not remain vacant due to high costs, a reduction in demand from key workers, or a shortage of mortgage finance. We will provide flexibility within legal agreements to allow different intermediate affordable models to be used depending on demand when the development is completed. We will also provide for intermediate affordable housing to be used as social rented housing where such this would be viable in the context of the overall financial viability of the development and any public subsidy available.
- 2.48 In the case of shared ownership housing, we will use legal agreements to reduce the costs to occupiers by:
- ensuring that buyers are able to buy a relatively low percentage share – generally we will set the minimum share at no more than 25%; and
  - limiting the level of the rent paid on the unsold share – generally we will set the maximum rent at 2% of the value of the unsold share.
- 2.49 Intermediate affordable housing is currently available to key workers, tenants of social rented housing, and other first-time buyers. The Government provides a definition of key workers on the Directgov website. The Council will not generally limit occupation of intermediate affordable housing to key workers. Where a restriction to key workers is appropriate in the context of the characteristics of the development or the area, Camden will generally use the Government definition of key

workers, subject to any updates or regional guidance by the Mayor. The current Government definition focuses on staff of public authorities such as the NHS, teachers, social workers, fire-fighters, the police and the armed forces. When considering the proportion of key worker housing appropriate to a development, the Council will have regard Development Policy DP3, the characteristics of the development and the area and the circumstances noted in paragraph 2.44 of this guidance.

### **Mix of dwelling sizes**

- 2.50 The Council's Residential development standards (included as section 4 of this CPG) give general guidance on the floorspace and internal arrangements for all housing tenures. In addition, homes of all tenures should meet lifetime standards in accordance with Development Policy DP6 and the CPG on Lifetime homes and wheelchair housing. Three other sets of guidance are particularly relevant to affordable housing design:
- Guidance from the Homes and Communities Agency – the current guidance (Housing Quality Indicators) applies to housing with public subsidy until April 2011. The agency is reviewing its guidance for subsequent investment.
  - We anticipate that housing with public subsidy in London will have to comply with the Mayor's London Housing Design Guide from April 2011 (published in interim form in August 2010).
  - The Mayor has prepared a draft replacement housing SPG. The Mayor's draft SPG supports the emerging replacement London Plan, which makes provision for residential standards to be applied across all tenures of development. Both the draft replacement London Plan and the draft replacement Housing SPG are expected to be adopted in autumn 2011.
- 2.51 This sub-section of the guidance is concerned primarily with the numbers of bedrooms that are expected as part of affordable housing development. Camden's Core Strategy indicates that we will seek a range of self-contained homes to meet identified dwelling size priorities. These priorities are set out in detail in our Development Policies document, which includes a Dwelling Size Priorities Table. For social rented housing, we prioritise all dwellings with two or more bedrooms, but the highest priority is given to social rented homes with 4-bedrooms or more. For intermediate affordable housing, we prioritise dwellings of all sizes, but give higher priority to dwellings with 2-bedrooms or more. More detailed guidance is given in the following Figure 3 and Figure 4.

**Figure 3. Mix of social rented housing**

<p><b>Overall aim: 50% of homes with 3 bedrooms or more</b></p> <p><b>Preferred mix:</b></p> <ul style="list-style-type: none"> <li>• 1-bedroom homes – no more than 20%</li> <li>• 2-bedroom homes – 30%</li> <li>• 3-bedroom homes – 30%, or 50% if no 4-bedroom homes are provided</li> <li>• 4-bedroom homes – 20%</li> </ul> <p><b>Other objectives:</b></p> <ul style="list-style-type: none"> <li>• Social rented homes should have physically separate kitchens and living areas where practical, particularly 3- and 4-bedrooms homes. We will seek the design of 100% of 3 bedroom and 50% of 2 bedroom social rented homes with physically separate kitchens and living areas.</li> <li>• At least 10% of homes should be designed, built and fitted-out to meet wheelchair housing standards in accordance with Development Policy DP6, subject to accompanying paragraph 6.9.</li> </ul>
---

**Figure 4. Mix of intermediate affordable housing**

<p><b>Overall aim: 10% of homes with 3 bedrooms or more</b></p> <p><b>Preferred mix:</b></p> <p>In order to meet needs while remaining within the cost limits set out in paragraphs 2.15 to 2.17 of this guidance, we expect most intermediate affordable homes in Camden developments to have 1- or 2-bedroom homes.</p> <ul style="list-style-type: none"> <li>• Studio flats – a proportion of studio flats may be acceptable, but we will generally resist development where all the intermediate affordable homes are studio flats</li> <li>• 1-bedroom homes – a proportion is expected in all schemes</li> <li>• 2-bedroom homes – a proportion is expected in all schemes</li> <li>• 3-bedrooms or more – 10% or more where it is possible to provide them within cost limits</li> </ul> <p><b>Other objectives:</b></p> <ul style="list-style-type: none"> <li>• We will seek the design of 20% of 2 bedroom intermediate homes with physically separate kitchens and living areas.</li> <li>• At least 10% of homes should be designed, built and fitted-out to meet wheelchair housing standards in accordance with Development Policy DP6, subject to accompanying paragraph 6.9.</li> </ul>
--

- 2.52 The precise mix of dwellings will be negotiated with developers, affordable housing providers and any employers involved in each scheme, taking into account the character of the development, the site and the area, and other criteria included in Development Policy DP5. We will take full account of guidance in the Development Policies document dealing with large homes, child density and separate kitchens (paragraphs 5.11 to 5.13), and wheelchair housing (paragraph 6.9). Any

proposals for affordable rented housing should include an appropriate mix of dwelling sizes having regard to paragraphs 2.50 and 2.51 of this guidance and to the cost of the proposed homes relative to social rented and intermediate affordable housing.

- 2.53 Where schemes involve both social rented housing and intermediate affordable housing, it may often be appropriate to have a high proportion of one-bedroom intermediate affordable homes and a high proportion of social rented homes with three bedrooms or more. Such schemes can potentially meet our dwelling size priorities while limiting the cost of the intermediate affordable housing and limiting overall child density.

### **How is affordable housing funded?**

- 2.54 Public subsidy will usually be needed to supply the proportions of affordable housing anticipated by the Core Strategy and Development Policies. The main source of public subsidy has been the Homes and Communities Agency until recently, although the Agency's framework document for 2011-2015 indicates that grant availability will be limited for affordable homes that are required by planning policy. The Council also administers its own affordable housing fund, which is formed from developer contributions where a payment-in-lieu has been provided instead of housing or affordable housing. The Council will consider providing subsidy from the affordable housing fund where funding from the Homes and Communities Agency (or successor organisations) is not available or is unable to secure an acceptable proportion and mix of affordable housing. In particular, the Council may offer subsidy from the affordable housing fund to secure additional large homes (3 or 4 bedrooms) and additional wheelchair housing.
- 2.55 PPS3 indicates that affordable housing should remain at an affordable price for future eligible households, or if these restrictions are lifted, the subsidy should be recycled. In practice, almost all additions to affordable housing in the borough that are associated with market development are transferred to a housing association on completion. Where this is the case, we will ensure that the property remains available as affordable housing by negotiating transfer of the freehold to the housing association. Where this is not possible, for example because of mixed-tenures or commercial uses within the block, the Council will negotiate for a long-lease to the housing association, ideally 125 years.
- 2.56 Where the affordable housing is to be transferred to a housing association, one or more housing associations will usually submit bids to the developer to indicate how much they are able to pay for the transfer of ownership. The payment will be inclusive of any public subsidy, the capitalised value of future rents, and the value of any equity that will be sold (usually arising from shared-ownership housing). Camden's Affordable Housing Viability Study 2009 estimated that where subsidy is available payments have typically been around 60% of the market value of social rented homes and 80% of the market value of shared-ownership homes. These estimates reduce to 40% and 60% respectively if no public subsidy is available. For specific schemes these

percentages will vary with market values, the availability of credit, levels of public subsidy, changes to Government controls on rents and changes to the Mayor's guidance on the income level of occupiers.

- 2.57 The Government has reduced the amount of public funding available for affordable housing. This is expected to lead to a reduction in the number of developments that receive subsidy and a reduction in the amount of any subsidy paid for each home. We acknowledge that if public subsidy is not available the proportions of affordable housing anticipated by the Core Strategy and Development Policies will not be viable in all developments.
- 2.58 In some cases, it may be possible to provide intermediate affordable housing without direct public subsidy, particularly shared ownership homes. Such opportunities can arise where land is acquired cheaply, where unusually small homes are developed, or where charitable contributions are available. We will actively pursue such opportunities, and (in accordance with paragraph 2.44 of this guidance) may be prepared to consider schemes with up to 100% intermediate affordable housing where the overall proportion of affordable housing floorspace in the development is substantially more than 50%. Where intermediate affordable housing is provided without public subsidy, we will still use a legal agreement to secure the long-term availability of the homes as affordable housing for eligible households.

### **How will the Council consider financial viability?**

- 2.59 Our Core Strategy and Development Policies outline a number of Council aims and commitments relating to housing and mixed-use development that provide a framework for considering financial viability:
- housing is the priority land-use of the Local Development Framework
  - we will seek to **maximise the supply of additional housing**, and
  - we will seek the **maximum reasonable amount of affordable housing** on each site, taking into account specific circumstances including the financial viability of the development
  - to maximise overall housing supply, we will implement policies flexibly in response to economic uncertainty
  - to ensure that housing development is viable, we may consider varying the proportion and/ or type of market and affordable housing in a development, or consider off-site solutions where necessary (see the sub-section '**Can the affordable housing be provided off-site?**')
- 2.60 Where a development provides an addition of 200 sq m or more (gross) of non-residential floorspace in the Central London Area or the larger town centres, applicants will need to demonstrate that the development is providing an appropriate contribution to the supply of housing. Where a development has capacity for 10 or more additional dwellings, applicants will need to demonstrate that the development is providing the maximum reasonable amount of affordable housing. In most cases, the applicant will be required to submit a financial viability appraisal to

justify the proportions of housing and affordable housing proposed. This requirement may be waived where the development provides the proportion and mix of housing and affordable housing sought by Development Policies DP1, DP3 and DP5.

- 2.61 As indicated in our Development Policies document, in certain circumstances the Council will expect applicants to fund an independent verification of the financial viability appraisal. Independent verification will be required where the proportion or mix of housing/ affordable housing sought falls considerably short of the contributions anticipated by our Development Policies document. This independent verification will either be:
- commissioned directly by the Council in negotiation with the applicant; or
  - commissioned by the applicant from an independent body subject the Council agreeing the body and the specifications in advance.
- 2.62 A financial viability appraisal is a balance sheet for the development which enables all scheme costs and revenues to be taken fully into account. Several viability appraisal models are available, and the Council does not insist that a particular model is used. The GLA publishes an Affordable Housing Development Control Toolkit (also known as the Three Dragons Toolkit), and most financial viability appraisals submitted to the Council are prepared using the Toolkit. The GLA Toolkit was designed specifically to assist negotiations between planning officers and developers. The Toolkit is reviewed annually.
- 2.63 Viability appraisal of development requires the input of a range of information including build costs, developer's return (profit) and sales values. We will expect the inputs to the viability appraisal to be backed up by evidence e.g. quotations for building works, residential sales values achieved for comparable developments in the area. The GLA's Development Control Toolkit provides benchmark values for some inputs. The guidance notes accompanying the GLA Development Control Toolkit are available free and provide more detailed information on which costs can appropriately be included in a viability appraisal. The Council will closely scrutinise development costs that exceed benchmark figures. Where independent verification of the appraisal is required, this should include confirmation that the inputs used are appropriate and are in accordance with the evidence.

**Figure 5. Typical inputs to financial viability appraisal**

<b>Cost inputs</b>	<b>Revenue inputs</b>
demolition and build costs	sales values
professional fees	payment by a housing association for transfer of affordable housing
marketing fees	public subsidy for affordable housing (if not included above)
development finance costs	capitalised rents (non-residential floorspace)
planning obligations other than affordable housing	yield (non-residential floorspace)
developer's return (non-residential floorspace and market housing)	
contractor's return (affordable housing)	

2.64 Some of the information required for viability appraisal may be regarded as commercially sensitive. If requested, the Council will endeavour to prevent release of sensitive information to third parties. However, subject to agreement with the applicant, release of sensitive information may be necessary in some circumstances, such as:

- to enable independent verification of the viability appraisal
- where another body has a role in considering the application such as the Mayor and the GLA
- where another body has a role in providing public subsidy for the development such as the Homes and Communities Agency, the Mayor and GLA
- where the development is subject to a planning appeal.

2.65 The Council will not expect viability appraisal to include land value or acquisition cost as a fixed input. Valuations and acquisition costs generally reflect an assumption by the valuer about what can be developed on the site, including an assumption about the proportions of non-residential development, market housing and affordable housing that will be acceptable. If land value forms a fixed input to the appraisal, the process becomes circular, and the proportions of market housing and affordable housing that are viable will match the initial assumption of the valuer. The Council's preferred measures of land value are given in Figure 6.



**Figure 6. Measures of Land Value**

<b>Residual Value:</b>	the value of a development once all scheme costs and revenues have been taken into account, including build costs, professional fees, developer's returns and S106 contributions, but excluding site acquisition cost.
<b>Existing Use Value (or EUV):</b>	the value of a site in its lawful use. The Council will require evidence of the EUV, for example the value of rents paid by an existing occupier, or values achieved for sale of comparable sites continuing in the same use. The EUV should take account of revenue from the lawful use and any refurbishment or development costs that would be incurred to re-commence lawful use of a vacated site.
<b>Alternative Use Value:</b>	the residual value of a site if developed for an alternative use. There should be a valid permission for the alternative use (or uses), or agreement should be reached with the Council about which other uses would comply with our Core Strategy and Development Policies. The Alternative Use Value should take account of revenue from the alternative use and development costs that would be incurred to commence the alternative use.

- 2.66 The residual value should be an output of the viability appraisal. The Council will consider the development to be viable if the residual value exceeds the existing use value and any relevant alternative use value. We will not normally consider the development to be viable if the existing use value is higher than the residual value. The Council will also consider site acquisition costs if these are supported by evidence. Evidence should generally include values achieved for sale of comparable sites. Where independent verification of the appraisal is required, this should include confirmation that the evidence of comparable sales values is appropriate.
- 2.67 We strongly advise applicants to discuss the general parameters of individual viability appraisals with us before they are prepared. Early discussions can ensure that the appraisal provides the evidence needed to assess the application and help to avoid delays after the application is submitted. For example, we will advise on whether viability appraisal of the proposed development should be accompanied by viability appraisal of alternative options such as:
- a development that meets our full expectations for housing and affordable housing contributions but is not viable
  - a development that partly meets our expectations for housing and affordable housing contributions
  - development for an alternative use
  - an alternative development falling below the relevant Development Policy thresholds (200 sq m in DP1 and 1,000 sq m in DP3)
  - a development above the thresholds that makes no contribution to housing or affordable housing
  - an off-site contribution to housing or affordable housing

## Can the market housing and affordable housing be provided off-site?

- 2.68 Our Core Strategy and Development Policies promote mixed-use development and mixed and inclusive communities in line with the Government's Planning Policy Statements PPS1 and PPS3. Development Policy DP1 indicates that housing contributions should normally be provided on site, while Development Policy DP3 indicates that affordable housing contributions should normally be made on site. Both policies do provide for off-site contributions, but only in a limited set of circumstances. The Council will only accept off-site contributions where provision cannot practically be achieved on-site in terms of meeting the criteria set out in the two Development Policies and accompanying paragraphs. The Council will only accept contributions in the form of payments-in-lieu in exceptional circumstances.
- 2.69 When considering the acceptability of off-site contributions and payments-in-lieu, we will have close regard to all relevant criteria in Development Policies DP1 and DP3 alongside accompanying paragraphs 1.15 to 1.24 and 3.13 to 3.30. We will also have regard to Core Strategy CS9 and the Council's support for residential communities in Central London, and ensure that off-site contributions do not undermine the benefits of mixed-use areas (such as those identified in paragraph 1.7 of our Development Policies document) or conflict with the creation of mixed and inclusive communities. Off-site contributions are most likely to be acceptable for small sites, whereas the Council will expect contributions to be made on-site where the development is larger. Where mixed-use policy DP1 applies, we will expect on-site housing contributions where 1,000 sq m (gross) or more of additional floorspace is proposed. Where affordable housing policy DP3 applies, we will expect on-site affordable housing contributions where 3,500 sq m (gross) or more of additional floorspace is proposed.

### Making the contribution on another site

- 2.70 The following terms are used in this guidance to shorten explanations of off-site arrangements:
- **application site** – the site of the proposed development that generates a policy requirement for housing under policy DP1 or affordable housing under policy DP3;
  - **delivery site(s)** – one or more proposed development sites elsewhere intended to meet policy requirements off-site.
- 2.71 The paragraphs accompanying policies DP1 and DP3 indicate that where off-site provision is made, the overall percentage of housing/affordable housing and non-residential uses will be considered across the aggregate floorspace on all related development sites. In other words, the percentage requirement for an off-site contribution is calculated as a proportion of the floorspace at the application site and the floorspace at the delivery site(s) added together, rather than the application site alone. In the case of policy DP1, where there is a single

target of 50% for negotiation of on-site contributions, off-site contributions should normally involve matching the non-residential floorspace increase at the application site with an equivalent increase in residential floorspace at the delivery site. In the case of policy DP3, where the sliding scale applies a formula is used to calculate off-site contributions. Figure 7 and Figure 8 below show how the off-site policy requirement can be calculated.

- 2.72 Calculating the percentage across floorspace on all related development sites helps to ensure that the policies do not provide an unintended incentive towards off-site contributions. Off-site contributions allow more non-residential floorspace (or market housing floorspace) to be developed at the application site. Considering the sites together ensures that this gain in non-residential floorspace (or market housing) also leads to a proportionate increase in residential floorspace (or affordable housing floorspace) at the delivery site.
- 2.73 Calculating the proportion across all related development sites also enables land swaps. A land swap enables a developer to offset additional non-residential floorspace (or market housing) at the application site by reducing non-residential floorspace (or market housing) elsewhere.
- Under DP1, redeveloping/ converting non-residential floorspace for off-site housing can be used to offset the addition of non-residential floorspace at the application site;
  - Under DP3, redeveloping/ converting market housing floorspace for off-site affordable housing can be used to offset the addition of market housing at application site.
- 2.74 A calculation of this type under policy DP1 is included in paragraph 1.16 of our Development Policies document and as Example 2 in Figure 7.

**Figure 7. Calculating off-site contributions under policy DP1**

Additional non-residential floorspace proposed	Generally under 1,000 sq m for off-site housing contribution to be considered
On-site housing target	50% of additional floorspace on the application site
Off-site housing target	50% of total additional floorspace (application site plus delivery site)
Housing floorspace required off-site	Should match total addition to non-residential floorspace across the related sites

**Example 1**

Total non-residential addition (all sites)	= 800 sq m
Housing floorspace required if on-site	= 400 sq m
Housing floorspace required off-site (with no conversion of non-residential floorspace)	= 800 sq m
Ratio of non-residential floorspace to housing floorspace off-site	800:800 = 50%:50%

**Example 2**

Non-residential addition on-site	= 800 sq m
Housing floorspace required if on-site (application site)	= 400 sq m
Non-residential change off-site (delivery site)	= minus 400 sq m through conversion to housing
Total non-residential addition (all sites)	= 400 sq m
Housing floorspace required off-site (by conversion of non-residential floorspace)	= 400 sq m
Ratio of non-residential floorspace to housing floorspace off-site	400:400 = 50%:50%

**Figure 8. Calculating off-site contributions under policy DP3**

Additional market housing floorspace proposed - 'a'	Generally under 3,500 sq m for off-site affordable housing contribution to be considered
On-site affordable housing target -'b' (percentage)	Varies according to the sliding scale for sites with capacity for less than 50 homes (NB the sliding scale does not apply where the primary application site also includes 1,000 sq m or more of additional non-residential floorspace – see paragraph 2.33 of this guidance).
Off-site affordable housing target (proportion)	$= b / (100 - b)$
Affordable housing required off-site (secondary delivery site) - 'c' (sq m)	$c = a \times b / (100 - b)$

**Example**

Additional market housing floorspace proposed	= 2,500 sq m
Target for on-site affordable housing	= 25% x 2,500 sq m = 625 sq m
Off-site affordable housing target	= 25 / (100 – 25) = 33.3%
Target for off-site affordable housing contribution	= 2,500 sq m x 33.3% = 833.3 sq m
Ratio of market housing floorspace to affordable housing floorspace off-site	2,500:833.3 = 75%:25%

- 2.75 Development Policies DP1 and DP3 indicate that we will take into account the economics and financial viability of development when considering off-site contributions as well as on-site contributions. The arrangements in paragraphs 2.59 to 2.67 of this guidance will apply, and applicants will need to submit financial viability appraisals to demonstrate that the application and delivery sites are providing the maximum reasonable contributions to housing (under DP1) or affordable housing (under DP3). Applicants will be required to fund an independent verification of the financial viability appraisal where the proportion or mix of housing/ affordable housing sought falls considerably short of the contributions anticipated by our Development Policies document and this guidance.
- 2.76 As indicated in paragraph 2.68 of this guidance, contributions to housing/ affordable housing should normally be made on site. Mechanisms guiding the delivery of housing and affordable housing should not create a financial incentive for the developer to make off-site contributions. Where the level of off-site contribution is below the level anticipated by our Development Policies document and this guidance,

we will seek to ensure the additional value created by the development is broadly the same with an off-site contribution as it would be with an on-site contribution. In addition to the financial viability appraisal requirements of paragraphs CPG12.59 to 2.67, the Council may therefore seek a comparison between the financial viability of on-site and off-site solutions (taking into account the existing use value and residual development value of the application site and delivery site).

### **Residential land-use credits and affordable housing credits**

- 2.77 Within Camden's Central London area there are a number of property investors and developers that own a significant number of sites. We may negotiate arrangements with such landowners to take advantage of commercial development opportunities, market housing opportunities and affordable housing opportunities on separate sites provided this does not compromise our objectives for mixed-use and mixed and balanced communities. In particular, owners of several sites may be able to bring forward developments of housing or affordable housing in advance of any policy requirement from Development Policies DP1 or DP3. In effect, the 'delivery site(s)' is/ are developed before the 'application site' has been identified (see paragraph 2.70 of this guidance for an explanation of these terms). The Council may agree to 'bank' this floorspace in the form of credits that can be accepted against the policy requirements from future development. When an 'application site' generates a housing/ affordable housing requirement, the Council will have discretion to agree to use of the 'banked' credits to offset part or all of the policy requirement.
- 2.78 The credits mechanism has potential to deliver additional housing and affordable housing earlier in the financial cycle by creating incentives for multiple site-owners to:
- seek opportunities for housing/ affordable housing development in advance during periods when commercial markets are poor rather than seeking to negotiate payments in lieu when commercial development prospects improve;
  - bring forward housing/ affordable housing development that they would otherwise hold back until commercial development prospects improve;
  - take up opportunities to convert lower value commercial properties to housing when leases expire;
  - provide affordable housing when the market for private housing would be unable to support it.
- 2.79 The mechanism can also help developers to deliver commercial floorspace or market housing more quickly when demand is strongest.
- 2.80 There are two types of credits that could be considered in this way:
- **residential land-use credits** – created where housing is provided but is not required by policy – these can be used where market

housing is needed to offset additional commercial development under Development Policy DP1; and

- **affordable housing credits** – created where affordable housing is provided in place of market housing but is not required by policy – these can be used where affordable housing is needed to offset additional market housing development under Development Policy DP3.

- 2.81 The two types of credit could potentially be created by a single development at the same time if affordable housing is provided but there is no policy requirement for any type of housing. However, each type of credit can only be used once and only against a single policy requirement.
- 2.82 Residential land-use credits and affordable housing credits are types of off-site contributions, and will be governed by the policy considerations set out in paragraph 2.68 and 2.69 of this guidance. Paragraphs 1.15 and 3.15 of our Development Policies document indicate that off-site contributions should be made in the same area as the application site. In the case of residential land-use and affordable housing credits, the Council will only agree to bank credits from development in the Central London area, and will only allow credits to be used to offset requirements on another site in Central London. Credits should be used in reasonable proximity to the delivery site. In the Central London context, in most cases the Council will require credits to be used within 500 metres of the delivery site, taking into account any demonstrable benefits from allowing provision on a more distant site. The Council will not agree to credit arrangements that would erode the mixed-use character of Central London or add to concentrations of affordable housing at the fringes of Central London.
- 2.83 The Council will use two mechanisms to ensure that residential land-use credits and affordable housing credits serve to increase the overall delivery of housing or affordable housing.
- The Council will not agree to the formation of credits from development of market housing or affordable housing where this development would clearly have arisen regardless of any future DP1/DP3 requirements on other sites.
  - Where we agree to the use of credits to off-set a housing requirement from additional non-residential space or an affordable housing requirement from additional market housing, the credit required will be equivalent in floorspace terms to the overall increase in non-residential floorspace – or market housing floorspace – across the application site and the delivery site(s) together, in accordance with the considerations set out in paragraphs 2.70 to 2.74 of this guidance.
- 2.84 The Council may therefore agree to acknowledge development in Central London as creating residential land-use credits and/ or affordable housing credits subject to the following constraints:

- the creation of credits should form part of the resolution to grant permission for housing/ affordable housing on the 'delivery site'
- the Council will only agree the formation of credits where this will serve to increase the overall delivery of housing or affordable housing
- the scale and type of credits created should be agreed at the time of the resolution on the 'delivery site' (floorspace of residential land-use credits and floorspace of affordable housing credits)
- at the request of the credit-holder, the Council may consider credits agreed by resolution as a material consideration offsetting policy requirements at a future 'application site' in Central London
- the Council will only accept the existence of credits as a material consideration where an off-site contribution would comply with Development Policies DP1, DP3 and all other relevant policies and material considerations
- the Council will only accept the existence of credits as a material consideration for sites in Central London
- the Council will require the credits to be used in reasonable proximity to the 'delivery site', and in most cases within 500 metres
- the Council will consider the scale of credits required to off-set a policy requirement in terms of the overall increase in non-residential floorspace increase or market housing floorspace across the application and delivery site(s) together
- the existence of credits will not place any obligation on the Council in terms of its decision-making in relation to a future 'application site'
- the period over which the credit can be applied to a future 'application site' should also be agreed at the time of the resolution on the 'delivery site', usually until 10 years from the date of the resolution
- the credits will generally be specific to an applicant, developer or landowner, and will not be regarded as transferable
- the creation and 'cashing-in' of credits and the implementation of development at 'delivery sites' and 'application sites' will be closely monitored and regularly reported.

### **Payments in lieu**

- 2.85 Development Policies DP1 and DP3 only allow payments-in-lieu of housing/ affordable housing in exceptional circumstances, and these will be governed by the policy considerations set out in paragraph 2.68 and 2.69 of this guidance. Payments-in-lieu may be accepted where the required housing/ affordable housing cannot practically be achieved on-site and the applicant demonstrates that no alternative site is available in the area (see paragraphs 1.17 and 3.15 of the Development Policies document). Payments-in-lieu of housing will be paid into the Council's affordable housing fund whether they arise under policy DP1 or policy DP3, as the Council does not hold funds for investment in market housing.



- 2.86 Where development proposals involve a shortfall of the housing or affordable housing required under Policies DP1 or DP3, the Council may negotiate a payment in lieu of the unmet requirement.
- 2.87 Where the Council considers that a payment-in-lieu of housing/ affordable housing is appropriate under policies DP1 or DP3, we will calculate the payment-in-lieu in accordance with CPG on **Planning Obligations**. The calculation is based on viability research commissioned by the Council to set a standard affordable housing payment-in-lieu. In negotiating a payment-in-lieu, the Council will also take into account the economics and financial viability of the particular development. Where a payment-in-lieu at the level anticipated by CPG on Planning Obligations would not be viable, the arrangements in paragraphs 2.59 to 2.67 of this guidance will apply.
- 2.88 As indicated in paragraph 2.76, financial appraisal mechanisms should not create an incentive towards off-site solutions. In addition to the financial viability appraisal requirements of paragraphs 2.59 to 2.67, the Council may therefore seek financial viability appraisal of the development with and without an on-site contribution, and will seek to ensure that any payment-in-lieu is broadly equivalent to the increase in development value where no contribution is made on-site. The Council may also consider the cost of developing the required percentage of housing/ affordable housing off-site.

### **Background**

- Government Planning Policy Statement PPS3 – Housing provides a definition of affordable housing and sets the framework which local councils use to secure affordable housing from market housing development.
- CLG guidance 'Delivering affordable housing' provides further information on delivery mechanisms that local councils can use to provide affordable housing.
- The London Plan and the Mayor's Housing SPG give guidance on the income groups who are eligible for affordable housing, and also cap the cost of affordable housing on the basis of income.
- The London Plan Annual Monitoring Report is used to review annually which income groups are eligible for affordable housing.

## **Securing works / conditions / S106**

- 2.89 Provision of housing required under Development Policy DP1 will generally be secured by a planning obligation under S106 of the Town and Country Planning Act 1990. The precise terms of the S106 agreement will vary between developments to reflect the nature and financial viability of the development. In most cases S106 terms will include:
- identifying all homes in the development
  - preventing the occupation of non-residential floorspace until the housing has been completed.
- 2.90 Provision of affordable housing required under Development Policy DP3 will always be secured through a S106 planning obligation. The precise terms of the S106 agreement will vary between developments to reflect the nature and financial viability of the development. In most cases, S106 terms will include:
- identifying all affordable homes in the development
  - specifying which homes will be social rented housing and which homes will be intermediate affordable housing
  - defining social rented housing in terms of the Government's national rent regime
  - defining intermediate affordable housing in terms of the income groups and the ratio of housing cost to income contained in the London Plan, the Mayor's Housing SPG and the London Plan Annual Monitoring Report
  - defining affordable rented housing in relation to lower quartile market rents available locally and across the borough
  - identifying social rented and intermediate affordable wheelchair homes
  - arrangements for the development, fitting out and transfer of the affordable housing to an affordable housing provider
  - preventing the occupation of some or all market housing until the affordable housing has been completed, fitted out and transferred to an affordable housing provider
  - securing availability of the affordable housing to future eligible occupiers, or securing recycling of public subsidy if the affordable housing is sold.
- 2.91 Other S106 terms that may be required in connection with DP1 and DP3 include:
- where off-site delivery will be at a known site or sites, linking the developments together
  - where a site is not identified for delivery at the outset, specifying the floorspace, nature of housing required and general location

- where a site is not identified for delivery at the outset, arrangements for identifying one or more delivery sites prior to the implementation of the development
- making a payment-in-lieu of housing/ affordable housing prior to implementation or occupation of the development
- arrangements for a deferred contribution to the affordable housing fund if provision of housing/ affordable housing falls short of targets due to financial viability, and there is a prospect of sales values increasing prior to completion
- specifying the type of intermediate affordable housing – e.g. key-worker, intermediate rent, shared ownership
- controls on the rents of intermediate rented housing and affordable rented housing
- limiting the minimum percentage share available in shared ownership homes
- limiting the rent charged on the unsold proportion of shared ownership homes.

## Resources / contacts

### Contacts

Guidance on interpretation of the LDF Core Strategy and Development Policies document	Strategic Planning and Information Team – 020 7974 5964 – or email <a href="mailto:LDF@camden.gov.uk">LDF@camden.gov.uk</a>
Guidance on our affordable housing priorities and our housing association partners	Camden Council Housing Partnerships Team – 020 7974 5564
Guidance on the pre-planning application advice service	<a href="http://www.camden.gov.uk/planning">www.camden.gov.uk/planning</a> (see Planning Applications pages) Camden Council Duty Planner Service – 020 7974 5613

### Resources

Affordable Housing Development Control Toolkit, GLA 2010	<a href="http://www.london.gov.uk/who-runs-london/mayor/publications/planning/affordable-housing-development-control-toolkit">www.london.gov.uk/who-runs-london/mayor/publications/planning/affordable-housing-development-control-toolkit</a> (accessed April 2011)
Camden Housing Needs Survey Update 2008	<a href="http://www.camden.gov.uk/ldf">www.camden.gov.uk/ldf</a> (see Evidence and Monitoring pages)
Delivering Affordable Homes – CLG guidance 2006	<a href="http://www.communities.gov.uk/publications/housing/deliveringaffordablehousing">www.communities.gov.uk/publications/housing/deliveringaffordablehousing</a> (accessed April 2011)
Housing – The London Plan Supplementary Planning Guidance, GLA, November 2005	<a href="http://www.london.gov.uk/who-runs-london/mayor/publications/planning/housing-supplementary-planning-guidance">www.london.gov.uk/who-runs-london/mayor/publications/planning/housing-supplementary-planning-guidance</a> (accessed April 2011)
Planning Policy Statement PPS3 – Housing – CLG2006	<a href="http://www.communities.gov.uk/publications/planningandbuilding/pps3housing">www.communities.gov.uk/publications/planningandbuilding/pps3housing</a> (accessed April 2011)



## 4 Residential development standards

### KEY MESSAGE

Development should provide high quality housing that provides secure, well-lit accommodation that has well-designed layouts and rooms.

- 4.1 This guidance relates to Camden Core Strategy policies CS5 – *Managing the impact of growth and development*, CS6 – *Providing quality homes* and CS14 – *Promoting high quality places and conserving our heritage* plus Camden Development Policy DP26 – *Managing the impact of developers on occupiers and neighbours*. In addition, homes of all tenures should meet lifetime homes standards in accordance with Development Policy DP6 and the CPG on Lifetime homes and wheelchair housing.

### TENURE

Describes the ownership of a home and the relationship between a household and their home i.e. owner-occupied, shared ownership, private rented, social rented, etc.

- 4.2 The '**Access for all**' section in CPG6 **Amenity** sets out the Council's approach to providing buildings and spaces that are accessible to everyone. Reference should also be made to the **Design Excellence** section of CPG1 **Design** and to other sections of CPG2 **Housing**.
- 4.3 The space standards in this guide are minimum requirements and should not be taken as maxima. Housing which exceeds the minimum standards will always be encouraged.
- 4.4 This guidance applies to planning applications involving the provision of residential accommodation and residential conversions, extensions and change of use. In cases involving residential conversions of listed buildings a sensitive and imaginative approach to achieving these standards may need to be taken.

### MAYOR'S HOUSING SPG

The Mayor has prepared a draft replacement housing SPG. The Mayor's draft SPG supports the emerging replacement London Plan, which makes provision for residential standards to be applied across all tenures of development. Both the draft replacement London Plan and the draft replacement Housing SPG are expected to be adopted in autumn 2011.

In addition, we anticipate that housing with public subsidy in London will have to comply with the Mayor's London Housing Design Guide from April 2011 (published in interim form in August 2010). The Mayor is seeking to adopt the London Housing Design Guide standards for all housing tenures in London through the London Plan.

- 4.5 Camden's Core Strategy indicates that we will seek a range of self-contained homes to meet identified dwelling size priorities. These

priorities are set out in detail in our Development Policies document – see particularly policy DP5 and paragraph 5.4.

## Guidance on residential development standards

### General principles

4.6 All residential developments in the Borough are required to be designed and built to create high quality homes:

- All newly created dwellings for households of 2 or more people should be self-contained (applies to homes in Use Class C3, but does not apply to care homes for elderly or vulnerable people, student housing, bedsits, or other Houses in Multiple Occupation (HMOs)).
- Each dwelling should have its own secure private entrance which leads either directly from the street or off a common entrance hall – the number of entrances off one corridor should be limited.

#### SELF-CONTAINED

Accommodation with its own kitchen, bathroom and toilet for the sole use of occupants behind a separate front door.

#### HOUSES IN MULTIPLE OCCUPATION (HMO)

HMOs are flats or houses permanently occupied by more than one household, where each household does not have exclusive access to all cooking, washing and toilet facilities behind a locked front door.

### Layout

4.7 There should usually be a permanent partition between eating and sleeping areas. Kitchens and living rooms that are permanently separated are preferable. However, combined kitchen and living areas are considered acceptable as long as the floor area is sufficient to allow for the greater range of activities that will take place in them.

### Rooms

- All rooms should be able to function for the purpose for the purpose for which they are intended.
- They should have an adequate size, shape, door arrangement, height, insulation for noise and vibration and natural lighting and ventilation.
- They should lead off a hallway or lobby so that it is possible to access any habitable room without passing through another habitable room, although Building Regulations Part B - Fire Safety allow inner rooms provided they meet certain criteria.

#### HABITABLE ROOM

A room that is capable of being used as primary living space. Generally consists of living rooms, dining rooms, large kitchen/diners and large bedrooms

### **Flexible construction/layout**

- 4.8 In addition, wherever practical dwellings should be designed to enable greater flexibility in construction design so that they can be capable of some form of extension or adaptation in order to accommodate changing lifestyles and family needs or other social use.
- 4.9 For example design features that could be considered, include:
- open plan layouts or generic layouts/floor plans;
  - avoiding load bearing internal walls;
  - easily accessible services and utilities e.g. a central accessible core or accessible floor/ceiling cavity.
  - For further examples see: By design urban design in the planning system: towards better practice: [www.communities.gov.uk/publications/planningandbuilding/bydesignurban](http://www.communities.gov.uk/publications/planningandbuilding/bydesignurban) by DETR (2000) (accessed April 2011).

### **Internal space standards**

#### **Ceiling heights**

- 4.10 All habitable rooms should have minimum headroom of 2.3 metres. The exceptions are habitable rooms in existing basements, which may have 2.1 metres headroom, and habitable rooms in attics which should have a minimum room height of 2.3 metres over at least half of the floor area (not including any floor space where the ceiling height is less than 1.5 metres). See Figure 1.
- 4.11 Any floor area where the ceiling height is less than 1.5 metres will not count towards the habitable floorspace. We will also consider the suitability of floor to ceiling heights in relation to context of building and how size of windows and floor to ceiling heights impact design. Please also refer to CPG1 **Design** (see particularly the sections on '**Design Excellence**' and '**Roofs, terraces and balconies**') and CPG4 **Basements**.



Figure 10. Ceiling heights

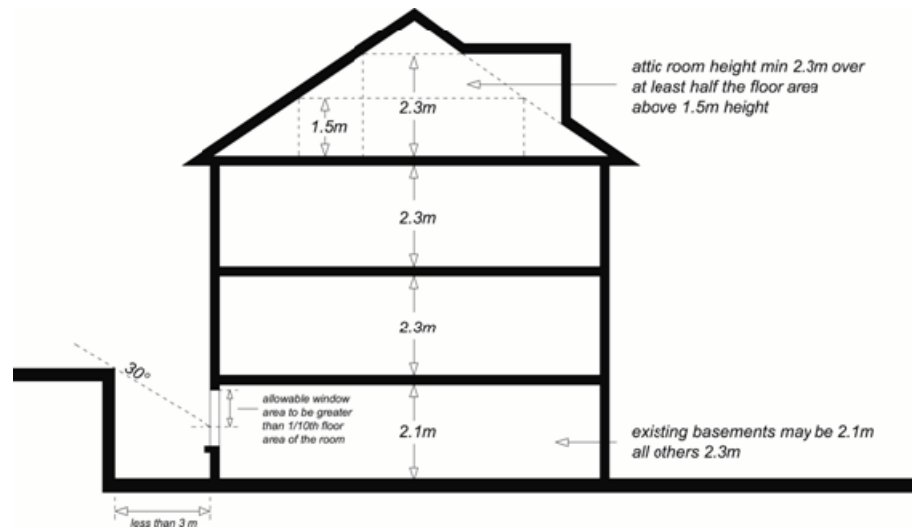

### Space and room sizes

- 4.12 Although planning cannot control the precise internal layout of individual proposals, it is important to ensure that dwellings are capable of providing a suitable layout and adequate room sizes that reflect the use and type of accommodation. The Council will be flexible in the application of these guidelines in order to respond to site-specific circumstances.
- 4.13 The Council has set minimum space standards to ensure rooms are large enough to take on varying uses. Space standards relate to the occupancy of a home rather than number of bedrooms and the developer will be required to state the number of occupants each dwelling has been designed to accommodate. The occupancy of housing at the time of its first occupation is not a reliable prediction of future levels of occupancy over the lifetime of a home. The only sensible assessment of occupancy is therefore the designed level of occupancy.
- 4.14 The overall internal floorspace in new self-contained dwellings (excluding communal lobbies and staircases) should normally meet or exceed the minimum standards set out in the following table.

Number of Persons	1	2	3	4	5	6
Minimum floorspace (sq m)	32	48	61	75	84	93

- 4.15 For dwellings designed for more than 6 people, allow approximately 10sq m. per extra person. In order to successfully to provide ease of movement and storage space for wheelchair users, the council will normally wheelchair housing dwellings to exceed the minimum floorspace standards. Please also refer to the section on 'Lifetime homes and wheelchair housing' in this CPG document.
- 4.16 The Council will expect bedrooms to meet or exceed the following minimum sizes:

- First and double bedrooms - 11.0 sq m
- Single bedrooms - 6.5 sq m

4.17 The Council's Private Sector Housing Team has produced specific minimum standards for Houses in Multiple Occupation (HMO's) and hostels which includes guidance on room sizes and facilities. Schemes for bedsits, shared houses and flats and hostels should be prepared with reference to these standards. These can be viewed on Camden's website [www.camden.gov.uk/housing](http://www.camden.gov.uk/housing) (see Private Sector Housing/ Private Housing Standards pages).

4.18 Self-contained homes providing a floorspace below the minimum standards may be considered in exceptional circumstances, for example to reduce the cost of Intermediate Housing to the occupier, however their acceptability will depend on other aspects of the development proposed. Sympathetic consideration may be given where a proposal meets a number of the criteria below:

- Dwellings are targeted at, and affordable to, groups identified by the Borough as being in need.
- External amenity space is provided
- A limited number of dwellings are accessed from each entry point and corridor (ideally 8 or fewer, unless controlled by a concierge or a CCTV system allowing clear facial identification).
- Security controlled access is provided where a larger number of units are accessed from one point.
- Where cluster flats are provided in response to a demonstrable demand (i.e. there are good indications that properties will not be hard to let to the targeted tenants), a limited number of flats are clustered into each dwelling (ideally 8 or fewer) (cluster flats are bedsits with a communal kitchen/eating area).
- A laundrette or communal laundry is provided (sufficient to cater for forecast resident demand at periods of peak usage) where individual dwellings cannot accommodate a washing machine - subject to keeping service and management charges at an acceptable level. The Council will take into account any existing commercial laundrettes that would be convenient for residents.

#### **Storage and utility spaces**

4.19 All accommodation should have sufficient internal storage space to meet the likely needs and requirements of potential occupiers. Dwelling layouts should make suitable provision:

- for washing machines and drying clothes;
- a storage cupboard with a minimum floor area of 0.8 sq m should be provided for 1- and 2-person dwellings;
- for each additional occupant, a minimum of 0.15 sq m storage area should be provided;

- storage for bicycles and prams should also be provided, located at the ground or lowest level of the dwelling, preferably accessed from a hall or lobby area;
- for waste and recycling bins, reference should also be made to the section '**Waste and Recycling Storage**' in CPG1 **Design**.

### **Daylight, sunlight and privacy**

- 4.20 Residential developments should maximise sunlight and daylight, both within the new development and to neighbouring properties whilst minimising overshadowing or blocking of light to adjoining properties. Maximising sunlight and daylight also helps to make a building energy efficient by reducing the need for electric light and meeting some of the heating requirements through solar gain. The orientation of buildings can maximise passive solar gain to keep buildings warm in winter and cool in summer.

#### **PASSIVE SOLAR GAIN**

Design to optimise the amount of the sun's energy that heats and lights a building naturally.

- 4.21 All habitable rooms should have access to natural daylight. Windows in rooms should be designed to take advantage of natural sunlight, safety and security, visual interest and ventilation. Developments should meet site layout requirements set out in the Building Research Establishment (BRE) Site Layout for Daylight and Sunlight – A Guide to Good Practice (1991).
- 4.22 Overall the internal layout design should seek to ensure the main living room and other frequently used rooms are on the south side and rooms that benefit less from sunlight (bathrooms, utility rooms) on the north side. Kitchens are better positioned on the north side to avoid excessive heat gain.

### **Minimum requirements:**

- 4.23 In particular the following minimum requirements need to be met to avoid the unacceptable loss of daylight and/or sunlight resulting from a development, including new build, extensions and conversions. For example:
- Each dwelling in a development should have at least one habitable room with a window facing within 30 degrees of south in order to make the most of solar gain through passive solar energy;
  - Rooms on south facing walls should always have windows, south facing windows and walls should be designed, sized and/or shaded in summer to prevent overheating. Appropriate shading might be achieved by:
    - mature deciduous trees located so as to shade the structure
    - eaves or overhangs that protect from sun that is high in the sky only

- external shutters or blinds that can be operated by the occupant;
- External shading should be provided for western facing windows and outdoor spaces to minimise overheating in summer. Deciduous trees provide the best shade for this purpose;
- Windows on north facing walls should be sized to prevent heat loss but allow sufficient daylight;
- All habitable rooms, including basements, must have an external window with an area of at least 1/10 of the floor area of the room;
- An area of 1/20 of the floor area of the room must be able to be opened to provide natural ventilation;
- Windows to atriums will be acceptable as external windows in exceptional circumstances only;
- Passive ventilation should be favoured where possible and mechanically assisted ventilation should be silent in operation.

4.24 For further guidance reference should be made to 'The Code for Sustainable Homes' which provides technical guidance on designing for adequate internal daylighting and requires daylight levels to be calculated using the BRE assessment method. Reference should also be made to CPG3 **Sustainability**.

### **Privacy and security**

- 4.25 House and flat developments should be arranged to safeguard the amenity and privacy of occupiers and neighbours.
- New development, extensions, alterations and conversions should not subject neighbours to unacceptable noise disturbance, overlooking or loss of security.
  - Developments should seek to improve community safety and crime prevention. This may include:
    - designing developments so that open spaces are overlooked by windows, avoiding dark secluded areas and buildings face onto streets.
    - obtaining Secured by Design certification – please refer to the '**Designing safer environments**' section of CPG1 **Design**.

### **Basements**

- 4.26 All rooms within a basement should be able to function for the purpose of which they are intended. They should have an adequate size, shape, door arrangement, and height, insulation from noise and vibration, and access to natural lighting, ventilation and privacy (similar to the standards set out above). Four key considerations are set out here.
- Natural light - to ensure that adequate natural light is provided to habitable rooms, walls or structures should not obstruct windows by being closer than 3 metres. Where this is not achievable it is advised

that the glazed area should total not less than 10% of the floor area of the room.

- Forecourt parking – nearby vehicles can also restrict light to basements, and consideration should be given to any further obstruction from vehicles parked on the forecourt that may present a barrier to light serving basement windows.
- Means of escape - basements should be provided with either a door or suitably sized window allowing access to a place of safety that gives access to the external ground level, or with a protected escape route within the building leading to a final exit at ground level.
- Lightwells - stairs, ladders and gates in any railings around a lightwell that are required for means of escape should be designed to be as discreet as possible and should have regard to the character of the building and surrounding area.

4.27 Further detailed guidance on basements is contained within CPG4 **Basements**.

### **Noise and soundproofing**

4.28 The layout and placement of rooms within the building should be carefully considered at an early stage in the design process to limit the impact of external noise on bedrooms and living rooms. The impact of noise should also be considered in the placement of private external spaces. Detailed guidance is provided in the '**Noise and vibration**' section of CPG6 **Amenity** and . The following requirements must be met.

- Internal layouts of dwellings should be designed to reduce the problem of noise disturbance between adjoining properties by using 'vertical stacking', i.e. placing living room above living room and bedrooms above bedrooms etc.
- Bedrooms should not be placed above, below or next to potentially noisy rooms, circulation areas of adjacent dwellings or noisy equipment, such as lifts.
- Windows should be located away from busy roads and railway lines/tracks to minimise noise and pollution and vibration.
- The layout of adjacent dwellings and the location of lifts, plant rooms and circulation spaces should seek to limit the transmission of noise to sound sensitive rooms within dwellings.
- Party walls and floors of flats created by conversion must be adequately soundproofed.
- All housing should be built with acoustic insulation and tested to current Building Regulations standards, but acoustic insulation should not be relied upon as the only means of limiting noise.
- Minimum levels of soundproofing are set out in the Building Regulations Part E - Resistance to the passage of sound. Levels of sound insulation above the minimum are encouraged.

- Further advice is given in the London Plan SPG on Sustainable Design and Construction

### **Outdoor amenity space**

4.29 Outdoor residential amenity space can be provided in the form of private garden space, balconies, terraces, roof gardens or as communal amenity space. Where practical the following requirements should be met.

#### **Private outdoor amenity space:**

- All new dwellings should provide access to some form of private outdoor amenity space, e.g. balconies, roof terraces or communal gardens.
- Private gardens should be allocated to family dwellings.
- Where provided, gardens should receive adequate daylight, even in the winter.
- The access to private amenity space should be level and should be from the main living space.
- Balconies should have a depth of not less than 1.5 metres and should have level access from the home.
- Balconies and terraces should be located or designed so that they do not result in the loss of privacy to existing residential properties or any other sensitive uses.
- Balconies should preferably be located next to a dining or living space and should receive direct sunlight (they can be designed to project from main building line or be recessed).

4.30 In some instances, it is accepted that existing buildings may not be able to provide balconies or roof terraces, however, external amenity space i.e. access to communal gardens should still be provided where possible. See CPG1 **Design** for further guidance on '**Roofs, terraces and balconies**'.

#### **Communal amenity space:**

- Space should meet the requirements of the occupiers of the building and be wheelchair accessible. For example, if there are a large proportion of family units, child and young person's facilities should be included in the communal space. The council will use the Mayor of London's 'Providing children's and young people's play and informal recreation SPG' (March 2008) when calculating requirements: <http://static.london.gov.uk/mayor/strategies/sds/spg-children-recreation.jsp> (accessed April 2011).
- Space should be well designed so that residents have a sense of ownership of the space, which will encourage its use.
- Space should be located sensitively so that it is overlooked by surrounding development and secure for residents.
- Space should be designed to take advantage of direct sunlight.

- Space should be designed to minimise disturbance to occupiers and neighbours, e.g. by being sheltered from busy roads, by being located in the rear of the buildings, back to back, behind perimeter blocks or in courtyards.
- Landscaping and facilities provided for the space should be of a high quality and have suitable management arrangements in place.

### Further information

GLA Housing Design Guide	The Mayor's London Housing Design Guide from April 2011 (August 2010) provides detailed guidance on housing design in London <a href="http://www.london.gov.uk/who-runs-london/mayor/publications/housing/london-housing-design-guide">http://www.london.gov.uk/who-runs-london/mayor/publications/housing/london-housing-design-guide</a> (accessed April 2011)
Lifetime Homes and Wheelchair Housing Standards	In addition to the above residential standards, most residential schemes will also need to meet specific requirements for Lifetime Homes and Wheelchair Housing Standards: <ul style="list-style-type: none"> <li>• For further guidance on how to meet Camden's requirements refer to CPG on Lifetime homes and wheelchair housing.</li> <li>• For good practice guidance specifically on Lifetime Homes <a href="http://www.lifetimehomes.org.uk">www.lifetimehomes.org.uk</a></li> </ul>
Daylight and Sunlight	For good practice advice on overshadowing and providing daylight and sunlight to buildings, refer to the widely used BRE Report "Site Layout Design for Daylight and Sunlight; a guide to good practice". It provides specific guidance on: <ul style="list-style-type: none"> <li>• Providing good daylighting and sunlighting within a new development</li> <li>• Safeguarding sunlight and daylight within existing buildings nearby</li> <li>• Protection of daylighting of adjoining land for future development</li> <li>• Passive solar site layout</li> <li>• Sunlighting of gardens and amenity areas</li> </ul>
Sustainability	The Council will require all that all buildings are designed to be sustainable, thus reference should also be made to CPG3 <b>Sustainability</b> , in particular, the 'Code for Sustainable Homes' sub-section in 'Sustainability assessment tools'.

## 5 Lifetime Homes and Wheelchair Housing

### KEY MESSAGES

- All residential development should meet the 16 criteria that form the Lifetime Homes standards.
- The standards will be applied flexibly to existing buildings, but applicants should justify failure to meet any of the criteria.
- 10% of market housing development should meet wheelchair housing standards, or should meet the 13 key Habinteg wheelchair housing criteria so that they can be easily adapted to meet wheelchair housing standards.
- 10% of affordable housing development should be designed, built and fitted out to meet Wheelchair Housing standards in full.

### What does this section cover?

- 5.1 This section provides advice on how proposals can made be accessible to all by incorporating “lifetime home” standards and creating wheelchair accessible homes. It supplements Camden Development Policies policy DP6 – *Lifetime homes & wheelchair housing*, as well as DP29 – *Improving Access* and Camden Core Strategy policy CS6 - *Providing quality homes*.
- 5.2 In line with policy DP6 all new residential development will be expected to meet the following standards.

#### LIFETIME HOMES

All housing developments should meet lifetime homes standards. A lifetime home is an ordinary home incorporating 16 design features for accessible living. These make homes easier to occupy for the entire life cycle of a household, whether its members are young, old, healthy or ill.

#### WHEELCHAIR HOUSING

A minimum of 10% of new housing should either meet wheelchair housing standards, or be easily adapted to meet them. Wheelchair housing provides independence and quality of life for wheelchair users and should be tailor-made for their specific needs.

- 5.3 In addition, the following building regulations should be considered where appropriate:
- Part M of the Building Regulations (2004 edition) – this sets minimum requirements for building standards in public buildings and new dwellings only.
  - BS 8300: 2009: Design of buildings and their approaches to meet the needs of disabled people – good practice guidance that covers non-domestic buildings and details on specific building types.
- 5.4 This planning guidance is applicable to all development. It applies equally to new build, refurbished, converted, extended and altered



premises. It should also be read in conjunction with the Council's 'Camden Wheelchair Housing Design Brief 2010'.

- 5.5 The application of Lifetime Homes and Wheelchair Housing Standards varies depending on the type of dwelling as follows (see also Development Policy DP6 and supporting paragraphs 6.7 to 6.9):
- Lifetime Homes standards apply to all developments of self-contained housing (but does not apply to hotels or student housing);
  - Wheelchair Housing Standards apply to all developments providing 10 or more self-contained homes and to student housing;
  - both sets of standards apply to housing in mixed-use developments as well as purely residential developments;
  - both sets of standards apply to new build development, conversions, reconfigurations and changes of use; and
  - the requirements will be applied flexibly to take account of the circumstances of existing buildings, particularly those that are listed. English Heritage has produced guidance on "Easy Access to Historic Buildings".

### **What is the guidance on Lifetime homes?**

- 5.6 Lifetime homes are ordinary homes built incorporating 16 design features for accessible living. These features ensure a good level of accessibility from the outset, but they also allow a dwelling to be easily adapted for even higher levels of accessibility in the future should the need arise eg to cater for raising young children and declining mobility in old age.
- 5.7 Lifetime homes standards are not designed specifically for disabled people or wheelchair users but allow for accessibility features to be easily incorporated at a later date if needed. There are separate Wheelchair Housing standards to guide the design of homes to meet the specific needs of people who are long-term wheelchair users (see paragraph 5.15)
- 5.8 By planning for accessibility at the earliest stage, the Lifetime Homes features can be incorporated into the design of a dwelling without significant additional cost and can result in major cost savings to the building's occupants in the long run (for a discussion of cost benefits and savings of Lifetime Homes, refer to 'Costing Lifetime Homes' by the Joseph Rowntree Foundation.)
- 5.9 The table on the following pages gives key features of the 16 criteria forming the Lifetime Homes standards. These came into effect on 5 July 2010. We advise developers to refer to [www.lifetimehomes.org.uk](http://www.lifetimehomes.org.uk) for additional and detailed guidance on how specific requirements can be met, and also for news of any future revisions.

## Lifetime Homes – Features

LIFETIME HOMES CRITERIA	KEY OBJECTIVES	DETAILED CRITERIA
<b>1. Parking (width or widening capability)</b>	<p>Provide, or enable by cost effective adaptation, parking that makes getting into and out of the vehicle as convenient as possible for the widest range of people (including those with reduced mobility and/or those with children).</p> <p>General Note: Criterion 1 is not relevant to developments that do not contain any parking provision (for specific requirements refer to <b>Camden Development Policy – DP18 Parking standards</b> and limiting the availability of car parking - which specifically discourages on-site parking).</p>	<p>a) 'On plot' (non-communal) parking: Where a dwelling has car parking within its individual plot (or title) boundary, at least one parking space length should be capable of enlargement to achieve a minimum width of 3300mm.</p> <p>b) Communal or shared parking: Where parking is provided by communal or shared bays, spaces should be provided with a width of 3300mm and in accordance with the specification given in Appendix 2 on page 65 or <a href="http://www.lifetimehomes.org.uk">www.lifetimehomes.org.uk</a>.</p>
<b>2. Approach to dwelling from parking (distance, gradients and widths)</b>	<p>Enable convenient movement between the vehicle and dwelling for the widest range of people, including those with reduced mobility and/or those carrying children or shopping.</p>	<p>The distance from the car parking space of Criterion 1 to the dwelling entrance (or relevant block entrance or lift core), should be kept to a minimum and be level or gently sloping. The distance from visitors parking to relevant entrances should be as short as practicable and be level or gently sloping.</p>
<b>3. Approach to all entrances</b>	<p>Enable, as far as practicable, convenient movement along other approach routes to dwellings (in addition to the principal approach from a vehicle required by Criterion 2) for the widest range of people.</p>	<p>The approach to all entrances should preferably be level or gently sloping, and in accordance with the specification given at <a href="http://www.lifetimehomes.org.uk">www.lifetimehomes.org.uk</a></p>
<b>4. Entrances</b>	<p>Enable ease of use of all entrances for the widest range of people.</p> <p>Note: For the purpose of requirements d) and e) of this Criterion, main entrances are deemed to be: the front door to an individual dwelling, the main communal entrance door to a block of dwellings, plus any other entrance door associated with the approach route from parking required by Criterion 2.</p>	<p>All entrances should:</p> <ol style="list-style-type: none"> <li>Be illuminated</li> <li>Have level access over the threshold; and</li> <li>Have effective clear opening widths and nibs as specified given at <a href="http://www.lifetimehomes.org.uk">www.lifetimehomes.org.uk</a></li> <li>In addition, main entrances should also:</li> <li>Have adequate weather protection*</li> <li>Have a level external landing.*</li> </ol>
<b>5. Communal stairs and lifts</b>	<p>Enable access to dwellings above the entrance level to as many people as possible.</p>	<p>a) Communal Stairs Principal access stairs should provide easy access in accordance with the specification given at <a href="http://www.lifetimehomes.org.uk">www.lifetimehomes.org.uk</a>, regardless of whether or not a lift is provided.</p> <p>b) Communal Lifts Where a dwelling is reached by a lift, it should be fully accessible in accordance with the specification given at <a href="http://www.lifetimehomes.org.uk">www.lifetimehomes.org.uk</a></p> <p>Note: provision of a lift is not a Lifetime Homes requirement, but is recommended where dwellings are not entered at the same level as the main block entrance.</p>
<b>6. Internal doorways and hallways</b>	<p>Enable convenient movement in hallways and through doorways.</p>	<p>Movement in hallways and through doorways should be as convenient to the widest range of people, including those using mobility aids or wheelchairs, and those moving furniture or other objects. As a general principle, narrower hallways and landings will need wider doorways in their side walls. The width of doorways and hallways should conform to the specification given at <a href="http://www.lifetimehomes.org.uk">www.lifetimehomes.org.uk</a>.</p>
<b>7. Circulation Space</b>	<p>Enable convenient movement in rooms for as many people as possible.</p>	<p>There should be space for turning a wheelchair in dining areas and living rooms and basic circulation space for wheelchair users elsewhere.</p>

## Lifetime Homes – Features (continued)

LIFETIME HOMES CRITERIA	KEY OBJECTIVES	DETAILED CRITERIA
<b>8. Entrance level living space</b>	Provide accessible socialising space for visitors less able to use stairs.	A living room / living space should be provided on the entrance level of every dwelling (see Appendix 1 on page 65 or <a href="http://www.lifetimehomes.org.uk">www.lifetimehomes.org.uk</a> for definition of 'entrance level'). Note: Entrance level generally means the storey containing the entrance door to the individual dwelling. It may refer to the first storey that contains a room (habitable or non-habitable) if the entrance door leads directly to an 'easy-going' stair.
<b>9. Potential for entrance level bed-space</b>	Provide space for a member of the household to sleep on the entrance level if they are temporarily unable to use stairs	In dwellings with two or more storeys, with no permanent bedroom on the entrance level, there should be space on the entrance level that could be used as a convenient temporary bed-space (see Appendix 1 on page 65 or <a href="http://www.lifetimehomes.org.uk">www.lifetimehomes.org.uk</a> for definition of 'entrance level').
<b>10. Entrance level toilet and shower drainage</b>	Provide an accessible toilet and potential showering facilities for: a) any member of the household using the temporary entrance level bed space of Criterion 9, and: b) visitors unable to use stairs.	Where an accessible bathroom, in accordance with Criterion 14, is not provided on the entrance level of a dwelling, the entrance level should have an accessible toilet compartment, with potential for a shower to be installed – as detailed in the specification given at (see Appendix 1 on page 65 or <a href="http://www.lifetimehomes.org.uk">www.lifetimehomes.org.uk</a> for definition of 'entrance level')
<b>11. Toilet and bathroom walls</b>	Ensure future provision of grab rails is possible, to assist with independent use of toilet and bathroom facilities.	Walls in all bathrooms and toilet compartments should be capable of firm fixing and support for adaptations such as grab rails.
<b>12. Stairs and potential through-floor lift in dwelling</b>	Enable access to storeys above the entrance level for the widest range of households.	The design within a dwelling of two or more storeys should incorporate both: a) Potential for stair lift installation; and b) A suitable identified space for a through-the-floor lift from the entrance level to a storey containing a main bedroom and a bathroom satisfying Criterion 14.
<b>13. Potential for fitting of hoists and bedroom / bathroom relationship</b>	Assist with independent living by enabling convenient movement between bedroom and bathroom facilities for a wide range of people.	Structure above a main bedroom and bathroom ceilings should be capable of supporting ceiling hoists and the design should provide a reasonable route between this bedroom and the bathroom.
<b>14. Bathrooms</b>	Provide an accessible bathroom that has ease of access to its facilities from the outset and potential for simple adaptation to provide for different needs in the future.	An accessible bathroom, providing ease of access in accordance with the specification given at <a href="http://www.lifetimehomes.org.uk">www.lifetimehomes.org.uk</a> should be provided in every dwelling on the same storey as a main bedroom.
<b>15. Glazing and window handle heights</b>	Enable people to have a reasonable line of sight from a seated position in the living room and to use at least one window for ventilation in each room.	Windows in the principal living space (typically the living room), should allow people to see out when seated. In addition, at least one opening light in each habitable room should be approachable and usable by a wide range of people – including those with restricted movement and reach. Note: In kitchens areas or bathrooms with only one window situated behind kitchen units or bathroom fittings, the requirement for a potential clear approach space to that window need not apply. However, the window handle height/control requirement remains applicable. Any other window within the kitchen area or bathroom, not behind fittings, is required to satisfy both the approach and window handle/control height requirements.
<b>16. Location of service controls</b>	Locate regularly used service controls, or those needed in an emergency, so that they are usable by a wide range of household members - including those with restricted movement and limited reach.	Service controls should be within a height band of 450mm to 1200mm from the floor and at least 300mm away from any internal room corner.

**APPENDIX 1 - DEFINITION OF 'ENTRANCE LEVEL' FOR THE PURPOSE OF LIFETIME HOMES CRITERIA**

The entrance level of a dwelling for the purposes of the Lifetime Homes Criteria is generally deemed to be the storey containing the main entrance door as defined by Criterion 4. This will usually be the ground floor of a house, or the storey containing the entrance door of a flat approached a communal hall, stair, or lift.

Where there are no rooms (habitable or non-habitable) on the storey containing the main entrance door (e.g. most flats over garages, some flats over shops, some duplexes and some townhouses), the first storey level containing a habitable or non-habitable room can be considered the 'entrance level' if this storey is reached by an 'easy going' stair with maximum risers 170mm, minimum goings 250mm, and a minimum width of 900mm measured 450mm above the pitch line.

**APPENDIX 2 - COMMUNAL CAR PARKING MANAGEMENT PLANS**

Where communal parking is provided, the Council may require a Parking Management Plan to ensure that adequate parking space is available for disabled people. The parking management plan should include a mechanism to ensure that the supply and demand of wider bays / blue badge bays are regularly monitored and provision reviewed, to ensure that provision equates to any change in the demand from disabled residents and visitors and that the bays are effectively enforced to stop abuse by non blue badge holders. The needs of residents who occupy a home designated for wheelchair users and any residents who hold a blue badge and occupy any other home should be addressed.

**Key requirements for lifetime homes standards:**

- 5.10 As the Building Regulations do not currently require dwellings to be built to lifetime homes standards it is necessary to check compliance at the planning application stage. Therefore planning applications for new housing are expected to include information in the design statement and access statement showing how the proposed development addresses the 16 Lifetime Homes Criteria. Information on access statements can be found in the '**Access for all**' section of CPG6 **Amenity**.

- 5.11 Applicants should specifically submit a schedule setting out how each of the 16 criteria will be met. Plans should particularly include sufficient detail of the following key internal space criteria, such as:
- 6 - Internal doorways and hallways
  - 7 - all necessary circulation space within and between rooms
  - 8 - an entrance level living space
  - 9 – potential for an entrance level space that can be used as a bed-space
  - 10 - entrance level toilet and shower drainage at entrance level
  - 12 – stairs and potential through-floor lift in dwelling
  - 14 - an accessible bathroom
- 5.12 In the case of conversion of an existing building or other circumstances of a development may mean it may not be possible for new homes to meet all 16 criteria. In this case, the development should still seek to meet Lifetime Homes Standards as far as possible to maximise accessibility and demonstrate to the Council's satisfaction why it is not possible to meet particular criteria.
- 5.13 Applicants should include a schedule within the design and access statement for their development that sets out:
- how each of the 16 Lifetime Homes criteria will be met;
  - identifying any Lifetime Homes criteria that will not be met;
  - demonstrating that these criteria cannot be met, or otherwise justifying failure to meet them.
- 5.14 The Council will expect developments involving listed buildings to incorporate accessible features. English Heritage has produced guidance on “Easy Access to Historic Buildings”. This guidance document should be referred to for further advice.

### **What is the guidance on wheelchair housing?**

- 5.15 In addition to requiring residential development to meet Lifetime Homes standards above, policy DP6 requires a minimum of 10% of all new housing designed to be suitable for permanent occupation by wheelchair users or be easily adapted to meet them. Wheelchair housing standards go significantly beyond Lifetime Homes standards, which do not provide for permanent wheelchair occupation.
- 5.16 The 10% requirement will be applied individually to each tenure within a given development scheme (ie applied to each affordability category whether market housing, social rented housing or intermediate affordable housing).
- 5.17 We may agree to increase the percentage of social rented wheelchair homes and decrease the percentage of intermediate affordable wheelchair homes (or vice versa) where this will better enable us to meet the needs of identified future occupiers.

**For market housing:**

- 5.18 We will encourage the provision of fully fitted out Wheelchair Housing, but will accept provision of 10% homes designed to be easily adaptable to meet the standards.
- 5.19 New homes that are capable of being easily adaptable should incorporate the key space criteria set out in the Habinteg Wheelchair Housing Design Guide (see Figure 11 below) and ensure that any fittings and fixtures required at a later date can be easily provided without enlarging or structurally altering the home.

**For affordable housing:**

- 5.20 The 10% wheelchair requirement should be designed, built and fitted out to meet Wheelchair Housing standards in full. These affordable homes should comply with the Camden Wheelchair Housing Design Brief 2010 produced by the Council.
- 5.21 As far as possible, the Council will seek to identify future occupiers of affordable wheelchair housing and seek to ensure that it is tailored to their needs.
- 5.22 The Council's Housing Partnerships Team should be consulted for any specific design requirements required to meet the needs of future occupiers of affordable wheelchair housing (see Further Information at the end of this guidance).
- 5.23 The Council may use its affordable housing fund to support the creation of fully-fitted out affordable wheelchair housing.

**Habinteg Wheelchair Housing Design Guide:**

- 5.24 All wheelchair housing should be designed in accordance with the standards set out in the nationally recognised Habinteg Wheelchair Housing Design Guide (WHDG).
- 5.25 The standards include guidance for main entrances, doors, hallways, storage space, bedroom space, windows, etc. Below are the 13 key space criteria relating to the internal layouts of individual dwellings. The main entrances and common parts should be designed in accordance with the relevant guidance (WHDG p30 & 31)

**Figure 11. Summary of the 13 key Habinteg wheelchair housing criteria**

1. Dwellings should normally be designed on one level storey. Where a dwelling is arranged in two or more floors a vertical rise lift serving all floors must be provided. (WHDG p63)
2. The entrance door to the dwelling should provide a minimum clear opening width of 800mm (when accessed head on) or 825mm (when the approach is not head on). It should be weather protected and lit and be provided with a 300mm clear space to the leading edge (pull side of the door) and a 200mm clear space on the push side. (WHDG p36)
3. The entrance hallway requires a manoeuvring space 1500 x 1800mm (enabling an occupier to open and close the door and turn into the living space) (WHDG p37 & 44)
4. A space to store and charge an electric wheelchair should be provided as an extension to the circulation space of the dwelling. Care should be taken to ensure that storage of the chair does not restrict the minimum clear effective width of any corridor. Consideration should be given to how the facility is accessed and used. To guarantee sufficient manoeuvring space an overall space of 1100 x 1700mm should be provided. (WHDG p45)
5. All halls and corridors (facilitating 90° turns) should have a clear unobstructed width of at least 1200mm and internal door clear opening widths of at least 800mm. To facilitate a 180° turn a corridor width of 1500mm is required. (WHDG p57)
6. All internal doors require a 300mm clear space to the leading edge (pull side of the door) and a 200mm clear space on the push side. (WHDG p58)
7. A 1500 x 1800mm turning circle should be provided in the kitchen. (WHDG p7)
8. In all bedrooms a 1200 x 1200mm clear space should be provided to one side of the bed, 1000mm circulation is required to the other sides and the foot of each bed. In single bedrooms access to one side of the bed is acceptable. All furniture and window controls should be reachable and usable. (WHDG p88)
9. In all bathrooms space should be provided to facilitate frontal, side and oblique transfer to the toilet. The bathrooms and toilets should normally have outward opening doors or provide a clear space of 1100mm between the door swing and any fixture or fitting. (WHDG p78)
10. All bathrooms should provide a 1500 x 1500mm square manoeuvring space, clear of all fittings (WHDG p78)
11. In all bathrooms a drainage gully and services to facilitate the installation of a level entry shower (1000 x 1000mm) should be provided. (WHDG p85)
12. A clear ceiling-track hoist route (suitably constructed and with a ready power supply) should be provided between the bathroom and the main bedroom (WHDG p80 & 15)
13. Windows should be able to be opened from a seated position. Controls should be located no higher than 1000mm above finished floor level and suitable for use by people with limited manual dexterity (WHDG p99)

For the latest edition of these standards, please refer to: "Wheelchair housing design guide" edited by Stephen Thorpe and available from Habinteg Housing Association:  
[www.habinteg.org.uk/pages/whdg.html](http://www.habinteg.org.uk/pages/whdg.html) (available from BREbookshop.com ISBN 1860818978)

### **Key requirements for wheelchair housing standards**

- 5.26 Planning applications will need to show which units are wheelchair accessible and how they are wheelchair accessible or how they can be easily adapted to be suitable for wheelchair users. Full wheelchair housing standards should be met within affordable housing and will be negotiated within market housing on a case by case basis.
- 5.27 Applications for planning permission should show full details of how 10% of homes will comply with wheelchair housing standards or, in the case of market housing, design features that ensure that 10% of homes are easily adaptable to meet the standards.
- 5.28 Plans should identify all wheelchair housing (or homes easily adaptable to the standards) and applications should include drawings setting out how the 13 key space criteria identified in Figure 11 will be met.
- 5.29 Applicants should include a schedule within the design and access statement for their development that sets out:
- how each of the 13 key space criteria will be met;
  - identifying any key space criteria that will not be met;
  - demonstrating that these criteria cannot be met, or otherwise justifying failure to meet them.
- 5.30 In the case of conversion of an existing building, we will apply the 10% requirement flexibly to take into account any constraints that would prevent the inclusion of entrances and internal spaces suitable for a wheelchair user.
- 5.31 For further design guidance on wheelchair housing please refer to the Mayor of London's SPG: 'Accessible London – Achieving an Inclusive Environment' (April 2004) - [http://static.london.gov.uk/mayor/strategies/sds/accessible\\_london.jsp](http://static.london.gov.uk/mayor/strategies/sds/accessible_london.jsp) (accessed April 2011).

### **Additional considerations**

#### **Requirements in other residential buildings**

- 5.32 In general, mobility difficulties and the need to provide for wheelchair users should be considered in the design of all forms of housing. The type of provision will need to be individually tailored to suit the nature of the facility and the likely needs of future occupiers.
- 5.33 In relation to student housing there is no requirement to meet Lifetime Homes standards, however, 10% of student bedrooms/ study flats (together with supporting communal spaces) are expected to meet wheelchair standards. Suitable design layouts are included in Approved Document M (known as Part M) of the Building Regulations.



### **Key building regulation requirements**

- 5.34 The accessibility of accommodation should be considered whether the proposal is for new build, conversions or refurbishments.
- 5.35 Part M of the Building Regulations sets minimum accessibility requirements for building standards in new residential dwellings and is required in addition to Lifetime Homes and wheelchair accessible housing standards being met. They apply at the Building Regulation approval stage and, as such, are not a matter for consideration in the planning process.
- 5.36 BS 8300:2009 'Design of buildings and their approaches to meet the needs of disabled people – Code of Practice' (BSI) provides good practice guidance for various types of non-domestic buildings.
- 5.37 For further information on part M of the Building Regulations or BS 8300:2009 please contact the Council's Building Control Service or refer to the regulations on the Department for Communities and Local Government's website:  
[www.communities.gov.uk/planningandbuilding/buildingregulations/](http://www.communities.gov.uk/planningandbuilding/buildingregulations/)

### **Securing lifetime homes and wheelchair housing through conditions and legal agreements**

- 5.38 Homes need to satisfy specific layout and space criteria in order to meet Lifetime Homes and Wheelchair Housing Standards. If homes are not designed to meet these criteria from the outset, it may not be possible to accommodate the necessary spaces within the envelope of the dwelling as proposed. Consequently, if submitted applications do not show dwellings that meet Lifetime Homes and Wheelchair Housing Standards, they cannot be secured by condition.
- 5.39 Conditions may be used exceptionally in connection with Lifetime Homes Standards where:
- constraints of an existing building will prevent layout and space criteria from being met
  - key layout and space criteria can clearly be met by the proposed housing, but other Lifetime Homes criteria have not demonstrably been met by submissions with the planning application.  
In each case, a condition may be used to secure submission of additional details of how specific Lifetime Homes criteria will be met before the development is implemented.
- 5.40 Development policy DP6 requires the provision of the 10% affordable wheelchair housing to be designed, built and fitted out to meet wheelchair housing standards in full. It will always be secured through a planning obligation (also known as a section 106 agreement or legal agreement). In most cases, the terms will specify:
- all wheelchair housing in the development

- which wheelchair housing will be social rented and which will be intermediate affordable housing
- arrangements to ensure that affordable wheelchair housing is fully fitted out to the agreed specifications, including payment of a bond where appropriate
- arrangements to ensure that affordable wheelchair housing is completed and fully fitted out to an acceptable timescale.

5.41 In some cases the terms may also specify:

- arrangements for submission of revised or additional plans or schedules where key space criteria have not demonstrably been met by submissions with the planning application;
- arrangements to ensure that affordable wheelchair housing can be viewed by potential occupiers before it is fitted out;
- arrangements to ensure that affordable wheelchair housing is available to wheelchair users in the future.

5.42 Provision of 10% wheelchair housing (or easily adaptable market housing) in market schemes is required but often future occupiers will be unknown until after the homes have been fitted out - under Development policy DP6 it may be exceptionally secured through a planning obligation where submissions with the planning application do not demonstrate that 10% of market homes meet the key space criteria. In such cases, the terms will specify:

- arrangements for submission of revised or additional plans or schedules showing that 10% of market homes meet key space criteria;
- arrangements to ensure that wheelchair housing is completed to the agreed specifications.

## Further information

<p>Lifetime Homes  <a href="http://www.lifetimehomes.org.uk">www.lifetimehomes.org.uk</a></p>
<p>Mayor's guidance at <a href="http://www.london.gov.uk/mayor/strategies/sds/docs/lifetime-homes.pdf">www.london.gov.uk/mayor/strategies/sds/docs/lifetime-homes.pdf</a> (accessed April 2011):          SPG 'Accessible London: Achieving an Inclusive Environment' (April 2004)          'Lifetime Homes – case study examples' (September 2006)          Best Practice Guidance 'Wheelchair Accessible Housing' (September 2007)</p>
<p>London Housing Design Guide (Mayor of London, August 2010)  <a href="http://www.london.gov.uk/who-runs-london/mayor/publications/housing/london-housing-design-guide">www.london.gov.uk/who-runs-london/mayor/publications/housing/london-housing-design-guide</a> (accessed April 2011)</p>
<p>Building Regulations 2000 Approved Document M - Access to and Use of Buildings (known as Part M)</p>
<p>British Standard BS 8300:2009 Design of buildings and their approaches to meet the needs of disabled people – Code of Practice (BSI)</p>
<p>British Standard BS 9999:2008 Code of Practice for Fire Safety in the Design, Management and Use of Buildings (BSI)</p>
<p>Camden Council Housing Adult and Social Care 'Camden Wheelchair Housing Design Brief 2010'</p>

Camden Planning Guidance

# Sustainability

London Borough of Camden

CPG **3**



## CPG1 Sustainability

1	Introduction .....	5
2	The energy hierarchy .....	7
3	Energy efficiency: new buildings .....	11
4	Energy efficiency: existing buildings .....	21
5	Decentralised energy networks and combined heat and power ...	31
6	Renewable energy .....	43
7	Water efficiency .....	55
8	Sustainable use of materials .....	59
9	Sustainability assessment tools .....	67
10	Brown roofs, green roofs and green walls.....	73
11	Flooding .....	79
12	Adapting to climate change.....	85
13	Biodiversity .....	89
14	Local food growing .....	107

**Index**

Air source heat pumps .....	49	Growing food .....	See Local food growing
Basements (flooding) .....	83	Habitat and Ecological surveys ...	93
Biodiversity .....	89	Insulation .....	23
Biomass heating and power .....	50	Lighting (biodiversity).....	93
BREEAM .....	69	Local food growing .....	107
Carbon offsetting.....	18	Materials ('healthy').....	64
Climate change (adaptation to) ...	85	Materials (sustainable use of).....	59
Code for Sustainable Homes .....	68	PassivHaus.....	18
Combined heat and power .....	31	Photovoltaic .....	46
Community heating .....	38	Protected species .....	90
Decentralised energy .....	31	Protected Species .....	101
EcoHomes .....	70	Rain water collection .....	56
Ecological surveys. See Habitat and Ecology Surveys		Renewable energy.....	43
Energy efficiency: existing buildings .....	21	Site Waste Management Plans ...	65
Energy efficiency: new buildings .	11	Solar/Thermal Hot Water Panels.	44
Energy hierarchy .....	7	Sustainable Drainage Systems ...	80
Energy statements .....	8	Thermal performance .....	13
Flooding.....	79	Waste Hierarchy .....	60
Geothermal.....	47	Water efficiency .....	55
Green and brown roofs .....	73	Wind turbines.....	52
Ground Source Heat Pumps .....	47	Zero carbon (assessment tools) ..	69
Ground water.....	82	Zero-carbon .....	18

# 1 Introduction

## What is Camden Planning Guidance?

- 1.1 We have prepared this Camden Planning Guidance to support the policies in our Local Development Framework (LDF). This guidance is therefore consistent with the Core Strategy and the Development Policies, and forms a Supplementary Planning Document (SPD) which is an additional “material consideration” in planning decisions. This new guidance will replace the Camden Planning Guidance 2006, updating advice where appropriate and providing new guidance on matters introduced or strengthened in the LDF.
- 1.2 The Camden Planning Guidance covers a range of topics as well as sustainability (such as design, housing, amenity and planning obligations) and so all of the sections should be read in conjunction, and within the context of Camden’s LDF.

## What is this sustainability guidance for?

- 1.3 The Council is committed to reducing Camden’s carbon emissions. This will be achieved by implementing large scale projects such as installing decentralised energy networks alongside smaller scale measures, such as improving the insulation and energy performance of existing buildings.
- 1.4 This guidance provides information on ways to achieve carbon reductions and more sustainable developments. It also highlights the Council’s requirements and guidelines which support the relevant Local Development Framework (LDF) policies:
  - CS13 - *Tackling climate change through promoting higher environmental standards*
  - DP22 - *Promoting sustainable design and construction*
  - DP23 - *Water*

**What does the guidance cover?**

- Energy statements
- The energy hierarchy
  - Energy efficiency – in new and existing buildings
  - Decentralised energy and combined heat and power (CHP)
  - Renewable energy
- Water efficiency
- Sustainable use of materials
- Sustainability assessment tools - Code for Sustainable Homes, BREEAM and EcoHomes
- Green roofs, brown roofs and green walls
- Flooding
- Climate change adaptation
- Biodiversity
- Urban food growing



## 2 The energy hierarchy

### KEY MESSAGES

- All developments are to be design to reduce carbon dioxide emissions
- Energy strategies are to be designed following the steps set out by the energy hierarchy

- 2.1 Buildings in Camden account for 88% of Camden's overall carbon dioxide emissions. These emissions result from the energy used within buildings. Therefore the Council encourages all buildings to be as energy efficient as possible. Our approach is to implement the energy hierarchy as set out in policy CS13 of the Core Strategy. The energy hierarchy is a sequence of steps that, if taken in order, will minimise the energy consumption in a building.
- 2.2 This section provides an overall introduction to the energy hierarchy and energy statements. This section sets out:
- The energy hierarchy
  - How to apply the energy hierarchy
  - When an energy statement is required
  - What to include in an energy statement
- 2.3 The next four sections provide more detailed guidance on each of the 3 steps in the hierarchy.

The 3 steps of the energy hierarchy are:

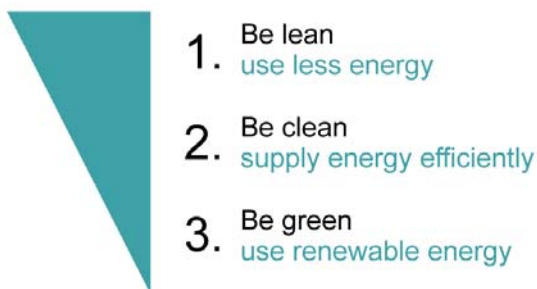

- 2.4 All developments are expected to reduce their carbon dioxide emissions by following the steps in the energy hierarchy to reduce energy consumption.
- 2.5 Developments involving 5 or more dwellings and/or 500sq m (gross internal) floorspace or more are required to submit an energy statement which demonstrates how carbon dioxide emissions will be reduced in line with the energy hierarchy (see below for more details on what to include in an energy statement).

**Gross internal area**

The area within the perimeter of the outside walls of a building as measured from the inside surface of the exterior walls, with no deduction for hallways, stairs, closets, thickness of walls, columns, or other interior features.

**What to include in an energy statement?**

- 2.6 An energy statement is to set out how a development has been designed to follow the steps in the energy hierarchy. It should demonstrate how the proposed measures are appropriate and viable to the context of the development.

**Baseline energy demand and carbon dioxide emissions**

Calculate the baseline energy demand of the development and the corresponding carbon dioxide emissions arising from the development. You should clearly show the methodology used. See below for more guidance on how to calculate the baseline demand and carbon dioxide emissions.

**Reduce the demand for energy**

Describe the design measures which are proposed to maximise the energy efficiency of the development. See sections 2 and 3 for guidance on how to ensure your development is as energy efficient as possible.

**Supply energy efficiently**

Describe how your development has considered further reducing carbon dioxide emissions by sourcing energy efficiently e.g. through the use of decentralised energy, such as combined heat and power systems. See section 4 for guidance on decentralised energy network and combined heat and power.

Calculate the energy use and the corresponding carbon emissions from the development having applied the first two stages of the energy hierarchy.

**Use renewable energy**

Describe how your development has considered using renewable energy technologies to further reduce carbon dioxide emissions. See section 5 for more guidance on renewable energy.

Calculate the remaining energy use and the corresponding carbon emissions from the development having applied all three stages of the energy hierarchy.

**Conclusion**

A concluding section should be provided outlining the contribution of each set of measures, technology or combination of technologies towards meeting the relevant targets set out in this guidance and providing recommendations as to which approach is most suitable for the site. Where it has not been possible to reach the targets, a clear explanation should be provided.

- 2.7 An energy statement should present technical data while remaining easy to read and to understand. Clearly laid out tables should be used to present data for ease of reading and comparison. Plans should be used where possible, e.g. to indicate suitable roof areas for installing solar technologies or the location of a plant room. References should be used to explain where data has been obtained from.

## Calculating the baseline energy demand and carbon dioxide emissions

- 2.8 You should produce a single energy statement for the entire development. The baseline energy demand should include an assessment of all the energy consumed in the operation of the development, including where there will be more than one occupier, use or building. This should include regulated energy or 'fixed' consumption (covered by building regulations) e.g. fixed lighting, heating and hot water systems, ventilation/cooling etc and non-regulated energy sources from 'plug-in' sources (not covered by building regulations) e.g. cooking, electrical appliances, centralised IT (server room) systems, communications equipment. Major developments should use modelling SAP/SBEM (Standard Assessment Procedure/Simplified Building Energy Model) to calculate this data. Benchmark data is only acceptable for minor developments.
- 2.9 The energy statement should clearly identify the total baseline energy demand and the carbon dioxide emissions of the development prior to the inclusion of any measures to reduce carbon dioxide emissions beyond the minimum requirements of current Building Regulations. The statement should clearly demonstrate the energy demand and carbon dioxide emissions of the development regulated by the Building Regulations as well as the additional energy demand and resulting carbon dioxide emissions. Reductions in each type of energy use should be demonstrated and the resulting total energy demand and carbon dioxide emissions.
- 2.10 Baseline carbon dioxide emissions should be calculated for energy use using Part L of the Building Regulations for domestic and non-domestic developments. Total development emissions should take into account all emissions sources.

### Further information

Camden Core Strategy	Policy CS13 - <i>Tackling climate change through promoting higher environmental standards</i> – sets out Camden's overarching approach to environmental sustainability.
Camden Development Policies	Policy DP22 - <i>Promoting sustainable design and construction</i> – sets out Camden's detailed requirements for developments to comply with.
Mayor of London	The London Plan Supplementary Planning Guidance, Sustainable Design and Construction: – sets out the Mayor's requirements for environmental sustainability.
GLA Energy Team Guidance on Planning Energy Assessments October 2010	Sets out how the GLA want Energy Assessments accompanying planning applications to be set out and what information is to be provided <a href="http://www.london.gov.uk/sites/default/files/guidance-energy-assessments-28-sep-10.pdf">www.london.gov.uk/sites/default/files/guidance-energy-assessments-28-sep-10.pdf</a>
Building Regulations	Approved Documents Part L - Conservation of Fuel and Power. This section of the Building Regulations deals specifically with the energy efficiency of buildings. The latest version of the Regulations can be found on the Planning Portal website <a href="http://www.planningportal.gov.uk">www.planningportal.gov.uk</a>

## 4 Energy efficiency: existing buildings

### KEY MESSAGES

As a guide, at least 10% of the project cost should be spent on environmental improvements

Potential measures are bespoke to each property

Sensitive improvements can be made to historic buildings to reduce carbon dioxide emissions

- 4.1 Many of the sections in this guidance focus on reducing the environmental impact of new buildings, however Camden's existing buildings account for almost 80% of the borough's carbon emissions. Therefore it is essential that these buildings make a contribution towards the borough's reduction in carbon dioxide emissions.
- 4.2 This section provides more information on how existing buildings can be more energy efficient. It builds on the previous section, which covered Stage 1 of the energy hierarchy and improving energy efficiency in new buildings.
- 4.3 Camden Core Strategy Policy CS13, paragraph 13.9 expects development or alterations to existing buildings to include proportionate measures to be taken to improve their environmental sustainability, where possible.

### WHAT DOES THE COUNCIL EXPECT?

- All buildings, whether being updated or refurbished, are expected to reduce their carbon emissions by making improvements to the existing building. Work involving a change of use or an extension to an existing property is included. As a guide, at least 10% of the project cost should be spent on the improvements.
- Where retro-fitting measures are not identified at application stage we will most likely secure the implementation of environmental improvements by way of condition. Appendix 1 sets out a checklist of retro fit improvements for applicants.
- Development involving a change of use or a conversion of 5 or more dwellings or 500sq m of any floorspace, will be expected to achieve 60% of the un-weighted credits in the Energy category in their EcoHomes or BREEAM assessment, whichever is applicable. (See the section on Sustainability assessment tools for more details).
- Special consideration will be given to buildings that are protected e.g. listed buildings to ensure that their historic and architectural features are preserved.

### How can I make an existing building more energy efficient?

- 4.4 There are many opportunities for reducing the energy we use in our homes. The design and the materials used can make a significant

contribution. Simple measures, such as closing curtains at dusk, can help stop heat loss. Installing condensing boilers, heating controls and energy saving light bulbs and appliances reduce energy use and carbon dioxide emissions significantly. Reduced energy use also means lower energy bills.

- 4.5 When dealing with historic buildings a sensitive approach needs to be taken. Guidance on this is provided later within this section.

### **Draught proofing**

- 4.6 There is a range of effective draft proofing measures you can use to help insulate your home:

- Fix brush seals to exterior doors and letterboxes, and tape to ill-fitting doors;
- Put reflector panels behind radiators to reflect heat into the room; and
- Use shutters for windows and/or thicker curtains that do not drape over radiators.

### **Energy efficient lighting**

- 4.7 In most homes lighting accounts for 20% of the electricity bill. It is easy to cut waste by simply turning off lights and adjusting blinds and curtains to let in more natural light. When lighting a room, always use energy saving light bulbs.

### **Windows**

- 4.8 Windows let light and heat into your home, but they can also let a lot of heat out when temperatures are colder outside than inside. If you are replacing windows or building an extension, thermally efficient glazed windows will provide more effective insulation than older windows.

Double glazed panels can now be fitted into some original wooden frames, without the need to replace the whole frame. This helps preserve the historic character of the building.

- 4.9 The use of PVCu windows is not considered to be acceptable in historic buildings, conservation areas and listed buildings as this material detracts from their historic significance and the architectural qualities of historic buildings and places. See below for more information on listed buildings and conservation areas.



- 4.10 There is a range of simple measures which can improve the energy efficiency of windows. These include:

- General repair and maintenance – which can substantially improve the energy efficiency of windows, as much of the heat lost through windows is through leaks and cracks.

- Installation of draught seals – which can help to further eliminate cold draughts and leaks.
- Secondary glazing – adding a second sheet of glass or plastic to a window frame can improve sound-proofing as well as energy efficiency. If carefully designed it can be unobtrusive and appropriate in a listed property or one within a conservation area.
- Secondary protection - e.g. shutters or heavy curtains, although these are predominantly a night-time option.

### **Insulation**

- Loft insulation - Your home may already have some loft insulation, but if the material is thin it will not be saving as much energy and money as it could. Fitting proper loft insulation is the most cost-effective way of saving energy. As a guide, your loft insulation should be around 250mm thick to be effective.
- Floor insulation - If you have any gaps between your floorboards and skirting boards, you can reduce heat loss by sealing them with a regular tube sealant, like the silicon sealant used around the bath. It is also very useful to insulate underneath the floorboards at ground floor level.
- Cavity wall insulation involves filling the gap between the bricks with insulating material. It can reduce heat loss by up to 60%. Most homes built after 1930 will have a cavity that could be insulated
- Solid wall insulation (internal or external) – buildings constructed before 1930 almost always have solid wall construction. The only way to insulate solid walls is to add insulation to the inside or outside of the wall. External insulation involves adding a decorative weather-proof insulating treatment to the outside of your wall while internal insulation involves attaching insulating plaster board laminates or wooden battens in-filled with insulation to the inside of the wall. Generally 100mm of insulation is required to be effective. Solid wall insulation, whether internal or external, will require relocation of the services attached to the wall e.g. radiators, electrical sockets, drainpipes.

### **Heating and hot water**

- New boiler - Replacing an old boiler (more than 10 years old) with a high efficiency condensing boiler and heating controls to provide heating and hot water could significantly cut energy consumption.
- New/upgraded central heating – If you install a new boiler the rest of your central heating system may need upgrading, for example large, old radiators could be replaced with smaller, more efficient radiators that are better suited to the new boiler
- Upgrading heating controls - You can install heating controls that allow you to control the temperature in different parts of your building. These can be included as an electronic timer control for your boiler, room thermostats for your main living area and thermostatic valves on all your radiators.

- Insulating hot water pipes and your hot water tank will retain hot water for longer, and save money on heating it.
- 4.11 See the Council's website for further information for householders on various retro-fitting measures and whether permission is required.

### Generating your own energy

- 4.12 Buildings can also reduce their energy consumption by generating their own energy in the form of heat or electricity using low carbon and renewable technologies which use little or no energy. See section 6 of this guidance on renewable energy for more advice on the technologies that are available and appropriate in Camden.

#### CASE STUDY

Renovated Victorian Eco-home: A semi-detached Victorian house in one of Camden's conservation areas was transformed in 2007, reducing its carbon footprint by 60%. Works undertaken to improve energy efficiency included:

- internal solid wall insulation;
- a new fully insulated roof;
- underfloor insulation;
- double glazing; and
- draught proofing.

Heat is provided by an efficient condensing boiler complemented by solar hot water panels on the rear extension; power to the panels' water pumps is provided by solar panels. Other improvements include an upgraded ventilation system with heat recovery, water saving features (e.g. rainwater harvesting for garden irrigation, dual flush toilets), low energy lighting and energy monitoring.

For further information on this property and improvements to other properties of a similar age see [www.sd-commission.org.uk](http://www.sd-commission.org.uk)



### What if my building is historic, Listed or in a conservation area?

- 4.13 Historic buildings have special features that need to be conserved and therefore need to be treated sensitively. This section explains how energy efficiency improvements can be achieved without causing harm to the historic environment.
- 4.14 Reflecting the special qualities of historic buildings, additional consents may be required for statutorily designated buildings (listed buildings, or those in conservation areas). The Council's website has more detailed guidance on what types of permission are required. The Council will aim to balance the conservation of fuel and power against the need to conserve the fabric of the building.



- 4.15 Historic buildings can perform well in terms of energy efficiency. When looking to install high energy efficiency measures, however, it is essential to ensure that works do not compromise the character and significance of the building or area.
- 4.16 In order to identify the most appropriate measures, we recommend taking the following approach, which takes into account measures best suited to individual buildings and households (i.e. taking human behaviour into consideration as well as the building envelope and services):
- Assess the heritage values of the building;
  - Assess the condition of the building fabric and building services;
  - Assess the effectiveness and value for money of measures to improve energy performance;
  - Assess their impact on heritage values; and
  - Assess the technical risks.
- 4.17 A range of thermal efficiency measures can then be implemented, which avoid harm to the historic environment. Ranked according to their impact on heritage and the technical risks, these include:
1. Ensure that the building is in a good state of repair
  2. Minor interventions - upgrade the easier and non-contentious elements:
    - insulate roof spaces and suspended floors;
    - provide flue dampers - (close in winter, open in summer);
    - use curtains, blinds and window shutters;
    - provide energy efficient lighting and appliances
    - draught-seal doors and windows;
    - provide hot water tank and pipe insulation.
  3. Moderate interventions - upgrade vulnerable elements:
    - install secondary (or double) glazing (if practicable);
  4. Upgrade building services and give advice to building users on managing them efficiently:
    - install high-efficiency boiler and heating controls;
    - install smart metering;
    - install solar panels, where not visible from the street or public spaces.
  5. Major interventions - upgrade more difficult and contentious elements (where impact on heritage values and level of technical risk shown to be acceptable)
    - provide solid wall insulation.
- 4.18 When considering refurbishment, it is the owner's responsibility to ensure that any work does not cause unlawful or unnecessary damage to the building.

- 4.19 The Energy Savings Trust and English Heritage have published detailed guidance on refurbishing and improving the efficiency of historic buildings. See the Further Information section below for details of where to find these guides.
- 4.20 Before carrying out any work, find out if your property is listed, in a conservation area or subject to any other planning restrictions such as an Article 4 Direction. Then check if any of the proposed works require consent – such as listed building consent, planning permission or conservation area consent. See CPG1 Design for more information on Camden’s historic buildings. The Council’s website also provides detailed information on these matters.

**Article 4 Direction**

Removes the permitted development rights awarded to properties by legislation and means a planning application has to be made for minor works that usually do not need permission.

## Further information

Energy efficiency in existing buildings:

The Energy Saving Trust	<p>A national agency promoting energy efficiency in the domestic sector. For information on home energy efficiency measures including grants, visit their website: <a href="http://www.energysavingtrust.org.uk">www.energysavingtrust.org.uk</a></p> <p>The Energy Saving Trust also provides technical guidance on energy efficiency in the Publications and Case Studies section of their website. <a href="http://www.est.org.uk/housingbuildings/publications">www.est.org.uk/housingbuildings/publications</a></p> <p>Recommended Best Practice in Housing technical guidance documents:</p> <ul style="list-style-type: none"> <li>• CE120 - Energy Efficient Loft Extensions</li> <li>• CE122 - Energy Efficient Domestic Extensions</li> </ul>
T-ZERO	<p>A free interactive web-based tool that allows you to identify the optimal low-carbon solutions for your home. Once you have inputted your home's details, such as type of house/flat, amount of insulation in roof/walls and whether or not you have double glazing, the system identifies a tailored list of optimal insulation, heating, and renewable energy options (and the costs of each). <a href="http://www.tzero.org.uk">www.tzero.org.uk</a></p>
GreenSpec	<p>Provides details of products and how they can be used to improve the efficiency of your home or building <a href="http://www.greenspec.co.uk">www.greenspec.co.uk</a></p>
The Planning Portal	<p>Provides information on what alterations you can make to your home without requiring planning permission <a href="http://www.planningportal.gov.uk">www.planningportal.gov.uk</a></p>

## Energy efficiency in historic buildings:

English Heritage	<p>English Heritage, the UK government's adviser on the historic environment, has produced the following guidance:</p> <ul style="list-style-type: none"> <li>• A Guide to Energy Conservation in Traditional Buildings, which looks at a range of improvements that can be made to reduce the heat lost through a building's walls, windows, floor and roof. This guide is one of a series looking at reducing energy consumption in traditionally constructed homes. <a href="http://www.english-heritage.org.uk/publications/energy-conservation-in-traditional-buildings/">http://www.english-heritage.org.uk/publications/energy-conservation-in-traditional-buildings/</a></li> <li>• Meeting building regulations Part L in existing buildings. The purpose of the guidance is to help prevent conflicts between the requirements of the regulations and the conservation of historic and traditionally constructed buildings. <a href="http://www.english-heritage.org.uk/publications/energy-efficiency-historic-buildings-partl/">http://www.english-heritage.org.uk/publications/energy-efficiency-historic-buildings-partl/</a></li> <li>• saving energy in historic buildings at <a href="http://www.climatechangeandyourhome.org.uk">www.climatechangeandyourhome.org.uk</a> which includes very detailed information about a wide range of improvements, e.g. insulating solid walls.</li> </ul>
The Energy Saving Trust	<p>Provides technical guidance on energy efficiency in the Publications and Case Studies section of their website. <a href="http://www.est.org.uk/housingbuildings/publications">www.est.org.uk/housingbuildings/publications</a></p> <p>This includes their Recommended Best Practice in Housing technical guidance documents: CE138 - Energy Efficient Historic Homes</p>
The Victorian Society	<p>Has information on their website on greening Victorian homes - <a href="http://www.victoriansociety.org.uk/advice/greening">www.victoriansociety.org.uk/advice/greening</a></p>
Building Conservation	<p>Provides a directory of useful contacts, grant sources and websites <a href="http://www.buildingconservation.com">www.buildingconservation.com</a></p>
The Sustainable Development Commission	<p>Provides case studies of existing homes that have improved their energy efficiency, including the example detailed in this section. <a href="http://www.sd-commission.org.uk">www.sd-commission.org.uk</a></p>

## Appendix 1: Checklist for retro-fitting measures

Applies to all:

- changes of use
- conversions
- extensions over 30sq m

Please note that not all the measures will be appropriate for all buildings and some measures will require planning permission e.g. alterations to the front of a property

Measure	Specification	Evidence
Draught proofing		
Reflective radiator panels		
Overhauling/upgrading windows		
New boiler		
LED lighting		
Meters, timers, sensors, controls on heating or lighting		
Mechanical Ventilation with Heat Recovery		
Insulation		
Hot water tank & pipes		
Roof		
Walls Internal		
Walls External		
Floor		
Renewable energy technology		
Solar PV panels		
Solar thermal (hot water) panels		
Ground source heat pumps		
Double glazed windows / Secondary glazing		
Combined heat and power unit		
Green or brown roof		
Rainwater harvesting		
Other measures		
Join the Camden Climate Change Alliance (commercial only)		
Off-setting contribution £3,000		



## 9 Sustainability assessment tools

### KEY MESSAGES

A new build dwelling will have to be designed in line with the Code for Sustainable Homes

The creation of 5 or more dwellings from an existing building will need to be designed in line with EcoHomes

500sq m or more of non-residential floorspace will need to be designed in line with BREEAM

- 9.1 A way to ensure buildings are sustainable is to use a standardised environmental assessment tool to measure the overall performance of buildings against set criteria. Buildings that achieve high ratings use less energy, consume less water and have lower running costs than those designed to building regulations alone.
- 9.2 Paragraph 13.8 of Core Strategy policy CS13 - *Tackling climate change through promoting higher environmental standards* notes that BREEAM and the Code for Sustainable Homes provide helpful assessment tools for general sustainability.
- 9.3 This section explains:
- when you need to carry out an assessment
  - what the assessment tools are
    - Code for Sustainable Homes
    - BREEAM
    - EcoHomes
  - The standards which need to be met for each type of development. These are more detailed targets for Energy, Water and Materials than those in the Development Policy DP22 - *Promoting sustainable design and construction*.
  - The information required at each stage of the assessment

### When do you need to carry out a sustainability assessment?

Development type	What does this include?	Threshold for assessment	Appropriate assessment tool
Residential - New build	New, self-contained houses and flats	all	Code for Sustainable Homes (CfSH)
Residential - Multi-occupation	Multi-residential buildings which contain a mix of residential accommodation (including student halls of residence, key worker accommodation, care homes and sheltered housing)	10 or more units/rooms or occupiers 500sq m of floorspace or more	BREEAM Multi-residential
Residential - Existing	Refurbishments, conversions and changes of use	5 dwellings or more 500sq m of floorspace or more	EcoHomes
Non-residential	Includes offices, retail, industrial, education health	500sq m of floorspace or more	BREEAM
Mixed use schemes	If your scheme includes both residential and non-residential uses that total 500sq m of floorspace or more we will require 2 assessments: a CfSH assessment for the residential part and also a BREEAM assessment for the non-residential parts.		

- 9.4 This table sets out when the Council will require a sustainability assessment for all the types of development and which assessment tool to use.
- 9.5 The assessment tools are updated periodically and therefore the most recent version of the assessment tool is to be used.

#### Code for Sustainable Homes

- 9.6 The Code for Sustainable Homes is an environmental impact rating system for all new housing. It sets standards for energy efficiency (above those in current building regulations) and sustainability. It aims to limit the environmental impact of housing.
- 9.7 The code works by awarding new homes a rating from Level 1 to 6, based on their performance against 9 sustainability criteria which are combined to assess the overall environmental impact. Level 1 is the



lowest and Level 6 is the highest. Homes that achieve level 6 are also known as 'zero carbon'.

#### **Zero Carbon**

Zero carbon refers to buildings that are so energy efficient they do not release any carbon emissions. The Government is currently aiming to ensure that all new homes are zero carbon by 2016. For more information visit [www.zerocarbonhub.org](http://www.zerocarbonhub.org)

- 9.8 The Code for Sustainable Homes has a clear timetable for the delivery of sustainable buildings up to 2016 when new housing will be expected to be zero carbon.

You are strongly encouraged to meet the following standards in accordance with Development Policy DP22 - *Promoting sustainable design and construction*:

Time period	Minimum rating	Minimum standard for categories (% of un-weighted credits)
2010-2012	Level 3	Energy 50%
2013 -2015	Level 4	Water 50%
2016+	Level 6 'zero carbon'	Materials 50%

#### **BREEAM**

- 9.9 BREEAM stands for Building Research Establishment Environmental Assessment Method. It is a tool to measure the sustainability of new non-domestic buildings. There are specific assessments for various building types such as offices, retail, industrial, education and multi-residential. For developments that are not covered by one of the specific BREEAM assessment tools, this often applies to missed use schemes, a tailored assessment can be created using the BREEAM Bespoke method
- 9.10 BREEAM assessments are generally made up of nine categories covering:
- Energy
  - Health and Well-being
  - Land use and Ecology
  - Management
  - Materials
  - Pollution
  - Transport
  - Waste
  - Water
- 9.11 Each of the categories above contain criteria which need to be met in order to gain credits. The higher the rating, the greater the number of specific credits needed. Some of the criteria have weighted credits which are used to reflect how important certain elements are, such as energy efficiency. All the credits are added together to produce the overall score. The development is then rated on a scale from PASS, to GOOD, VERY GOOD, EXCELLENT and ending with OUTSTANDING

You are strongly encouraged to meet the following standards in accordance with Development Policy DP22 - *Promoting sustainable design and construction*:

Time period	Minimum rating	Minimum standard for categories (% of un-weighted credits)
2010-2012	'very good'	Energy 60%
2013+	'excellent'	Water 60% Materials 40%

### EcoHomes

- 9.12 Ecohomes is a version of BREEAM for housing. It is used to assess the sustainability of existing housing where refurbishment, conversion or a change of use is proposed. It uses the same principles as BREEAM with categories, criteria and credits.

You are strongly encouraged to meet the following standards in accordance with Development Policy DP22 - *Promoting sustainable design and construction*:

Time period	Minimum rating	Minimum standard for categories (% of un-weighted credits)
2010-2012	'very good'	Energy 60%
2013+	'excellent'	Water 60% Materials 40%

- 9.13 BRE are developing BREEAM for Domestic Refurbishments scheme to replace EcoHomes. We may update this guidance to reflect this change in the future.

### What are the relevant stages?

#### Pre-assessment

- 9.14 The pre-assessment stage involves an initial review of the development to determine how sustainable it will be. It provides you with an early indication of the overall score your development will achieve by using the plans and drawings to estimate the number of credits that are likely to be achieved for each category. The results of the pre-assessment identify changes that need to be made to your scheme before construction begins to ensure it is as sustainable as possible. The pre-assessment stage also helps to identify if there are any experts, such as ecologists, that you need to invite to become involved in the development.
- 9.15 The results of your pre-assessment will form the basis of the condition or Section 106 planning obligation for the final development, so accuracy is crucial. In some circumstances it may be appropriate to over estimate

the credits needed to achieve the final rating as some credits can be lost during the final design stages.

**AT THIS STAGE THE COUNCIL WILL EXPECT:**

- The submission of a pre-assessment report at the planning application stage. The report should summarise the design strategy for achieving your chosen level of BREEAM and/or Code for Sustainable Homes and include details of the credits proposed to be achieved.
- The pre-assessment report is to be carried out by a licensed assessor. The name of the assessor and their licence number should be clearly stated on the report.

**Design stage assessment**

- 9.16 The aim of the design stage assessment is to review the detailed design specifications of your development. More detailed site specific information is generally available at this stage, in comparison to the pre-assessment stage, which allows the assessor to make a more precise estimate of the BREEAM or Code rating. Some elements of the assessment will need to be refined once construction has begun, because some materials and appliances are not specified until after or during construction. However, the assessor will ensure that any design and/or specification changes are reflected in the final Design Stage Assessment.
- 9.17 Once the assessor has completed the assessment it is submitted to the BRE for review and certification. The BRE will then issue a BREEAM or Code for Sustainable Homes Design Stage certificate indicating what level of sustainability the development has achieved.

**AT THIS STAGE THE COUNCIL WILL EXPECT:**

- Submission of an early design stage assessment to the Council prior to beginning construction of the development. This is needed to discharge the relevant condition or Section 106 planning obligation
- Ensure the assessor submits the final Design Stage Assessment to BRE for certification
- Submission of a copy of the Design Stage certificate to the Council

**Post-construction assessment**

- 9.18 The post-construction assessment reviews the design stage assessment and compares it with the completed development to ensure that all the specified credits have been achieved. It is carried out once your development has been completed and is ready for occupation. Once the assessment has been completed, it needs to be submitted to BRE for certification.

**AT THIS STAGE THE COUNCIL WILL EXPECT:**

- A post-construction assessment to be carried out as soon as possible after completion
- Submission of a copy of the post-construction certificate to the Council
- Submission of a copy of the Design Stage certificate to the Council, if not already submitted

- 9.19 There is often a delay between the completion of a development and the receipt of a post-construction certificate. Therefore the Council will allow occupation prior to the receipt of the final certificate. This approach will be monitored to ensure that the design stage certificate is consistent with the final post-construction report and certificate.

**Further information**

BRE (Building Research Establishment)	Provides detailed information on sustainability assessments, including the Code for Sustainable Homes, how to find an assessor, example assessments and how to submit your assessment: <a href="http://www.bre.co.uk">www.bre.co.uk</a>
BREEAM	Provides detailed information on all the different types of BREEAM assessments that are available, how to use them, how to find an assessor, what all the different stages are and other useful guidance: <a href="http://www.breeam.org">www.breeam.org</a>
The Code for Sustainable Homes	The Communities and Local Government website provides guidance and background information on the Code for Sustainable Homes: <a href="http://www.communities.gov.uk/planningandbuilding/theenvironment/codesustainable">www.communities.gov.uk/planningandbuilding/theenvironment/codesustainable</a>
Zero Carbon Hub	This organisation is working with the Government to implement the target towards ensuring all new homes are zero carbon. Their website provides information on what zero carbon is, how it can be achieved and case studies: <a href="http://www.zerocarbonhub.org">www.zerocarbonhub.org</a>

Camden Planning Guidance

# Amenity

London Borough of Camden

CPG 6



## CPG6 Amenity

1	Introduction .....	5
2	Air quality .....	7
3	Contaminated land .....	15
4	Noise and vibration .....	19
5	Artificial light .....	25
6	Daylight and sunlight .....	31
7	Overlooking, privacy and outlook .....	37
8	Construction management plans .....	39
9	Access for all .....	45
10	Wind and micro-climate .....	53
11	Open space, outdoor sport and recreation facilities .....	59
12	Planning for healthy communities .....	79

**Index**

Access (disabled).....	45	Micro-climate . See Wind and micro-climate	
Air quality.....	7	Noise and vibration.....	19
Allotments.....	62	Open space .....	59
Construction management plans	39	Overlooking.....	37
Contaminated land .....	15	Play Space.....	61
Daylight and sunlight.....	31	Privacy .....	See Overlooking
Green spaces .....	62	Right to light.....	35
Healthy communities.....	79	sport and recreation facilities.....	59
Hot food takeaways.....	81	Wind and micro-climate .....	53
Lighting.....	25		

Strategic Planning and Information  
London Borough of Camden  
Town Hall Extension, Argyle Street  
London WC1H 8EQ  
Tel: 020 7974 2043 / 2519  
Fax: 020 7974 1930  
Email: [ldf@camden.gov.uk](mailto:ldf@camden.gov.uk)  
[www.camden.gov.uk](http://www.camden.gov.uk)



# 1 Introduction

## What is Camden Planning Guidance?

- 1.1 We have prepared this guidance to support the policies in our Local Development Framework (LDF). It is therefore consistent with the Camden Core Strategy and Development Policies, and is a formal Supplementary Planning Document (SPD) which is an additional “material consideration” in planning decisions. This guidance will replace Camden Planning Guidance 2006, updating advice where appropriate and providing new guidance on matters introduced or strengthened in the LDF.
- 1.2 Camden Planning Guidance covers a range of topics (such as design, housing, sustainability and planning obligations) and all of sections should be read in conjunction with, and within the context of, Camden’s other LDF documents.

## Amenity in Camden

- 1.3 A key objective of the Camden Core Strategy is to sustainably manage growth so that it avoids harmful effects on the amenity of existing and future occupiers and to nearby properties.

## What does this guidance cover?

- 1.4 This guidance provides information on all types of amenity issues within the borough and includes the following sections:
  1. Air quality
  2. Contaminated land
  3. Noise and vibration
  4. Artificial light
  5. Daylight and sunlight
  6. Overlooking, privacy and outlook
  7. Construction management plans
  8. Access for all
  9. Wind and micro-climate
  10. Open space, outdoor sport and recreation facilities

- 1.5 This guidance supports the following Local Development Framework policies:

## Camden Core Strategy

- CS5 - Managing the impact of growth and development
- CS15 - Protecting and improving our parks and open spaces & encouraging biodiversity
- CS16 - Improving Camden’s health and well-being

**Camden Development Policies**

- DP26 - Managing the impact of development on occupiers and neighbours
- DP28 - Noise and vibration
- DP31 - Provision of, and improvements to, public open space and outdoor sport and recreation facilities
- DP32 - Air quality and Camden's Clear Zones

## 7 Overlooking, privacy and outlook

### KEY MESSAGES:

- Development are to be designed to protect the privacy of existing dwellings;
- Mitigation measures are to be included when overlooking is unavoidable;
- Outlook from new developments should be designed to be pleasant;
- Public spaces benefit from overlooking as natural surveillance.

- 7.1 This section aims to ensure that when designing your development you successfully consider the potential impact on the privacy and outlook of neighbouring properties.
- 7.2 This guidance relates to Core Strategy policy CS5 Managing the Impact of Growth and Development and Core Strategy policy CS14 Promoting high quality places and conserving our heritage.
- 7.3 Policy *DP26 – Managing the impact of development on occupiers and neighbours* of the Camden Development Policies outlines how the Council will protect the quality of life of occupiers and neighbours by only granting permission for development that does not cause harm to amenity.

### Overlooking and privacy

- 7.4 Development should be designed to protect the privacy of both new and existing dwellings to a reasonable degree. Spaces that are overlooked lack privacy. Therefore, new buildings, extensions, roof terraces, balconies and the location of new windows should be carefully designed to avoid overlooking. The degree of overlooking depends on the distance and the horizontal and vertical angles of view. The most sensitive areas to overlooking are:
- Living rooms;
  - Bedrooms;
  - Kitchens; and
  - The part of a garden nearest to the house.

### WHAT IS GOOD PRACTICE?

To ensure privacy, there should normally be a minimum distance of 18m between the windows of habitable rooms of different units that directly face each other. This minimum requirement will be the distance between the two closest points on each building (including balconies).

- 7.5 Where this standard cannot be met we may require you to incorporate some of the following design measures into your scheme to ensure

overlooking is reduced to an acceptable level. Design measures to reduce the potential for overlooking and the loss of privacy include:

- Careful consideration of the location of your development, including the position of rooms;
- Careful consideration of the location, orientation and size of windows depending on the uses of the rooms;
- Use of obscure glazing;
- Screening by walls or fencing; and
- Screening by other structures or landscaping.

7.6 Where landscaping is used as a method of screening, arrangements for ongoing maintenance should be put in place and this may be secured by a planning condition.

7.7 Public spaces and communal areas will benefit from a degree of overlooking due to the increased level of surveillance it can provide.

### **Outlook**

7.8 Outlook is the visual amenity enjoyed by occupants when looking out of their windows or from their garden. How pleasant an outlook is depends on what is being viewed. For example, an outlook onto amenity space is more pleasant than an outlook across a servicing yard. You should design developments so that the occupiers have a pleasant outlook. You should screen any unpleasant features with permanent landscaping.

7.9 When designing your development you should also ensure the proximity, size or cumulative effect of any structures do not have an overbearing and/or dominating effect that is detrimental to the enjoyment of their properties by adjoining residential occupiers. You should carefully consider the location of bin or cycle stores if they are in close proximity to windows or spaces used by occupiers.

7.10 You should take particular care if your development adjoins properties with a single aspect over your development.

7.11 You should note that the specific view from a property is not protected as this is not a material planning consideration.

### **Further information**

*Better Places to Live: By Design - A companion guide to PPG3 (ODPM)* makes number of design recommendations which recognise the importance of privacy in the home.

*Perceptions of Privacy and Density in Housing* report available from Design for Homes; 0870 416 3378 or [www.designforhomes.org](http://www.designforhomes.org). This report highlights some of the issues facing households living at higher densities, and the implications for future design of buildings.

## 8 Construction management plans

### KEY MESSAGES:

- Construction management plans are required for developments that are on constrained sites or are near vulnerable buildings or structures;
- They are essential to ensure developments do not damage nearby properties or the amenity of neighbours.

- 8.1 The purpose of this guidance is to give details on how construction management plans can be used to manage and mitigate the potential impacts of the construction phase of a development.
- 8.2 All construction and demolition work will cause at least some noise and disturbance. Where construction impact is particularly significant Camden will ensure it is managed through a legally binding construction management plan.
- 8.3 This guidance relates to Core Strategy Policy CS5 Managing the impact of growth and development and policies DP20 Movement of goods and materials, and DP26 Managing the impact of development on occupiers and neighbours of the Camden Development Policies.

### When does this guidance apply?

- 8.4 This guidance applies to all development proposals which, having regard to the nature of the surrounding area, are likely to give rise to significant noise and other disturbance during construction. Details on the circumstances in which the Council will expect construction management plans are set out within this guidance.

### How should construction management plans be prepared?

- 8.5 Camden's planning policies make it clear that the effect on local amenity and the highway network from construction and demolition is a material planning consideration. Construction management plans are used to set out the measures a developer should take (both on-site and off-site) in order to reasonably minimise and manage the detrimental effects of construction on local amenity and/or highway safety. Usually Camden will secure construction management plans through a Section 106 Agreement, although sometimes for less complicated schemes they may be secured by using a condition attached to planning permission.
- 8.6 Whilst construction management plans are a 'planning led' document they will incorporate mechanisms controlling planning considerations that overlap with other regulatory regimes (particularly highways and environmental protection). Hence, most construction management plans will be an umbrella document managing all impacts of the demolition, excavation and construction process.

- 8.7 Besides ensuring measures under these different regimes are coordinated in one document, construction management plans represent a proactive way of dealing with construction issues. They encourage developers to work with the Council and local people in managing the construction process with a view to ensuring that problems do not arise in the first place.

**Circumstances Camden will expect a construction management plan**

- 8.8 Whether a construction management plan is required for a particular scheme will be assessed on a case by case basis, although the Council will usually require a construction management plan for larger schemes (i.e. over 10 residential units or 1,000sq m of new commercial floorspace). However, occasionally a relatively large development will have comparatively little impact on its neighbourhood.
- 8.9 Conversely, small schemes on confined or inaccessible sites can have very significant impacts, particularly where the construction process will take place over a number of months (or even years) or outside normal working hours. When assessing smaller developments, special regard should be had to on-site factors that would seriously exacerbate the impact of the development works on the surrounding area. These could include development in residential areas, in close proximity to a school or a care home or very narrow or restricted site access (e.g. development in a mews with no footways). Regard will also be had to the nature and layout of a site. It will be much more difficult to fully absorb or contain the effects of demolition and construction in terms of noise, dust vibration etc within the boundaries of a small constrained site. Furthermore, lack of on-site space for plant, storage of materials and loading and unloading of construction may mean that construction effects will inevitably take place close to the boundary and spill out on to the highway network – a particular issue in much of Camden.
- 8.10 The types of schemes where a CMP will usually be appropriate include:
- Major developments (and some larger scale non major developments);
  - Development where the construction process has a significant impact on adjoining properties particularly on sensitive uses;
  - Developments which give rise to particular 'on-site' issues arising from the construction process (e.g. large scale demolition or complicated or intrusive remediation measures);
  - Basement developments;
  - Significant developments involving listed buildings or adjacent to listed buildings;
  - Developments that could seriously affect wildlife;
  - Developments that could cause significant disturbance due to their location or the anticipated length of the demolition, excavation or construction period;

- Development where site specific issues have arisen in the light of external consultation (where these are supported by objective evidence); and
- Development on sites where constraints arising from the layout or size of the site impact on the surrounding road network.

### **Contents of a construction management plan**

- 8.11 Any construction management plan will manage on-site impact arising from demolition and construction. It will also seek to establish control over construction traffic and how this integrates with other construction traffic in the area having regard to the cumulative effect.
- 8.12 A Section 106 or planning permission securing a construction management plan will contain provisions setting out in detail the measures the final version of the construction management plan should contain. Most construction management plans will be umbrella documents managing all impacts of the demolition, excavation and construction processes. This would include (but is not limited to) issues such as:
- Dust, noise and vibration on site and off site;
  - Traffic management highways safety and highways congestion;
  - Protection of listed buildings (if relevant);
  - Stability of adjacent properties;
  - Protection of any off-site features that may be damaged due to works;
  - Protection of biodiversity and trees; and
  - Preserve the amenity of surrounding residential and other sensitive uses.
- 8.13 A construction management plan is often split into two elements. The first element will be focussed on controlling environmental impacts, pollution and other non-highway related impacts arising from the scheme, having regard to the requirements of the Council's Considerate Contractor Manual and best practice guides from the GLA. In particular this will seek to control hours of operation and monitor and manage air quality, noise, dust and other emissions of other pollutants and location of equipment. The second element will be focussed on traffic control with a view to minimising disruption, setting out how construction work will be carried out and how this work will be serviced (e.g. delivery of materials, set down and collection of skips), with the objective of minimising traffic disruption and avoiding dangerous situations for pedestrians and other road users.
- 8.14 Sometimes the Section 106 will link the construction management plan with a requirement to convene a working group to act as a forum for the developer to meet with local residents and businesses to deal with construction issues as they arise.

- 8.15 Construction management plans will also have to be consistent with any other plans required for the development. For example, a Site Waste Management Plan, which is a legal requirement for works over a certain size which may require the re-use or recycling of materials on-site and therefore the construction management plan will have to reflect that space will be required to sort, store and perhaps crush or recycle materials.
- 8.16 The construction management plan should include the following statement:  
“The agreed contents of the construction management plan must be complied with unless otherwise agreed with the Council. The project manager shall work with the Council to review this construction management plan if problems arise in relation to the construction of the development. Any future revised plan must be approved by the Council and complied with thereafter.”

### **Transport considerations**

- 8.17 The details contained within a construction management plan will relate to the nature and scale of the development, however, in terms of assessing the impact on transport the plan should demonstrate that the following has been considered and where necessary the impacts mitigated:
- a) Start and end dates for each phase of construction;
  - b) The proposed working hours;
  - c) The access arrangements for vehicles;
  - d) Proposed routes for vehicles between the site and the Transport for London Road Network (TLRN). Consideration should also be given to weight restrictions, low bridges and cumulative effects of construction on the highway;
  - e) Sizes of all vehicles and the frequency and times of day when they will need access to the site, for each phase of construction;
  - f) Swept path drawings for any tight manoeuvres on vehicle routes to the site;
  - g) Details (including accurate scaled drawings) of any highway works necessary to enable construction to take place;
  - h) Parking and loading arrangements of vehicles and delivery of materials and plant to the site;
  - i) Details of proposed parking bays suspensions and temporary traffic management orders;
  - j) Proposed overhang (if any) of the public highway (scaffolding, cranes etc);
  - k) Details of any temporary buildings outside the site boundary, or overhanging the highway;
  - l) Details of hoardings required or any other occupation of the public highway;



- m) Details of how pedestrian and cyclist safety will be maintained, including any proposed alternative routes (if necessary), and any banksman arrangements;
- n) Details of how traffic associated with the development will be managed in order to reduce congestion;
- o) Arrangements for controlling the movements of large/heavy goods vehicles on and in the immediate vicinity of the site, including arrangements for waiting, turning and reversing and the provision of banksmen, and measures to avoid obstruction of adjoining premises.
- p) Details of any other measures designed to reduce the impact of associated traffic (such as the use of construction material consolidation centres);
- q) Details of how any significant amounts of dirt or dust that may be spread onto the public highway will be cleaned or prevented;
- r) Details of any Construction Working Group that may be required, addressing the concerns of surrounding residents, as well as contact details for the person responsible for community liaison on behalf of the developer, and how these contact details will be advertised to the community;
- s) A statement confirming registration of the site with the Considerate Constructors Scheme;
- t) How the servicing approach takes into consideration the cumulative effects of other local developments with regard to traffic and transport;
- u) Provision for monitoring of the implementation of the CMP and review by the council during the course of construction works;
- v) Any other relevant information with regard to traffic and transport; and

### **Air quality and climate change considerations**

8.18 A method statement should be prepared and adopted as part of the construction management plan to minimise gaseous and particulate matter emissions generated during the Construction Phase. The following best practice measures shall be included in the method statement:

- Techniques to control PM<sub>10</sub> and NO<sub>x</sub> emissions from vehicles and plant;
- Techniques to control dust emissions from construction and demolition;
- Air quality monitoring; and
- Techniques to reduce CO<sub>2</sub> emissions from construction vehicles.

### **How will we secure construction management plans?**

8.19 Generally a Section 106 agreement (rather than a condition) is the most appropriate mechanism for securing a construction management plan. For larger schemes or developments on constrained sites within heavily

built-up areas where building activities could materially affect the highway construction management plans will always be secured through Section 106s. While the use of conditions is normally preferred to Section 106 Agreements, conditions can only be used to control matters on land within the developer's control. The range of matters typically covered by a CMP, particularly in relation to highways, mean that a Section 106 Agreement will be necessary in most cases.

- 8.20 The level of detail contained in a typical Section 106 also lends itself to the tailored, site-specific approach Camden uses for construction management plans. However, the use of a condition to secure a construction management plan may be sufficient for sites where the building activities associated with the build out can be totally accommodated within the site itself, particularly where these are smaller schemes.

## 9 Access for all

### KEY MESSAGES:

- Well designed, accessible buildings and spaces ensure that local services and facilities are accessible to everyone and increase equality of opportunity and social inclusion. We will seek to ensure the highest standards of access and inclusion in Camden's built environment and public realm.
- We expect all development of buildings and places, including changes of use and alterations to or refurbishment of existing buildings where practical and reasonable, to be designed to be accessible and useable by all to promote equality of opportunity.
- Access should be considered at the beginning of the design process.

- 9.1 A successfully accessible and inclusive environment is one that everyone can benefit from by being able to move freely, independently and uninhibited within the built environment regardless of age or disability.
- 9.2 This guidance applies to all development in Camden that may affect the accessibility of buildings and spaces.
- 9.3 All new developments should incorporate a suitable level of access for everyone and be inclusively designed.
- 9.4 Changes of use, alterations and extensions to existing buildings and spaces should, where practicable and reasonable, be designed to improve access for all.
- 9.5 The planning system is not able to require existing buildings or areas to retrospectively improve access where alterations are not being made.
- 9.6 For developments involving housing, reference should also be made to Camden Development Policies policy DP6 – *Lifetime homes & wheelchair housing* and Camden Planning Guidance on Lifetime homes and wheelchair housing. The accessibility needs are lower for certain sectors of the population, such as students, and so the Council will assess each development proposal on its own merits to determine a suitable level of accessible accommodation to be provided.
- 9.7 Guidance on the provision of parking spaces for drivers with disabilities is contained in Camden Planning Guidance on Vehicle access.
- 9.8 This guidance provides general advice on accessibility and advises on further sources of more detailed information. In particular this guidance relates to Core Strategy policy CS14 - *Promoting High Quality Places and conserving our heritage*; CS6 - *Providing quality homes* and policy DP29 - *Improving access* of the Camden Development Policies.
- 9.9 It is more effective to consider access arrangements from the beginning of the design process as they are an integral aspect of building design.

Overcoming access barriers at a later stage in the project can result in a building or space that is not inclusive and may be inaccessible to many people.

- 9.10 Applicants are advised to consult the Council's Building Control Service at an early stage in the formulation of development proposals to ensure conformity with the relevant requirements relating to access. Satisfying some of the requirements of Part M of the building regulations can affect the size and design of the building and needs to be taken into account at the early design stage.
- 9.11 The following table sets out four key principles which, if put together successfully, should help create an accessible environment:

## Principles of access

Key Principle	Features to be considered
1. Approach  Parking	<ul style="list-style-type: none"> <li>• Level or adequately ramped</li> <li>• Sufficient width and obstacle free</li> <li>• Firm, durable, slip resistant surfaces</li> <li>• Well lit and clearly identified</li> <li>• Dropped kerbs with tactile surfaces</li> <li>• Contrasting colour on bollards and street furniture</li> <li>• Suitably designed and marked spaces</li> <li>• Spaces as close as possible to all accessible entrances</li> <li>• Dropped kerbs onto a level obstruction free route to the accessible entrance</li> <li>• Appropriately located and signed dropping off point</li> </ul>
2. Entrances  Lobbies  Receptions	<ul style="list-style-type: none"> <li>• Level or adequately ramped and stepped if necessary with appropriately designed handrails</li> <li>• Ramped gradients as shallow as possible</li> <li>• Level area in front of the door</li> <li>• Level threshold</li> <li>• Canopy over manual doors</li> <li>• Easy to open doors</li> <li>• Provision of electronic entrance doors</li> <li>• Sufficiently wide doors</li> <li>• Doors to have contrast.</li> <li>• Need to be of a size and shape to allow a wheelchair user to move clear of one door before opening the second door</li> <li>• Floor surface that does not impede movement, avoid dips or changing surfaces, including mats</li> <li>• Provide hearing enhancement systems and lowered wheelchair accessible counters.</li> <li>• Should be easily identifiable</li> </ul>
3. Levels  Circulation	<ul style="list-style-type: none"> <li>• Provide a lifting device and suitable stairs to all storeys above and below ground</li> <li>• Ramps for internal changes within a storey</li> <li>• Any raised areas to be accessible to everyone</li> <li>• Adequately wide corridors.</li> <li>• Sufficiently wide doors</li> <li>• Clear, well lit signs</li> <li>• Colour contrast within the building</li> <li>• Corridors free of obstructions</li> </ul>
4. Facilities	<ul style="list-style-type: none"> <li>• Adequate provision of wheelchair accessible unisex toilets</li> <li>• Provision of an enlarged cubicle in separate sex toilets</li> <li>• Where shower and changing facilities are included provide wheelchair accessible facilities</li> <li>• Provision of wheelchair accessible hotel bedrooms</li> <li>• Appropriately designed sockets and switches</li> </ul>

### Additional information

- 9.12 Level access should be provided to the principal entrance in all developments, and is a requirement for all new dwellings. Any new works must not make access any worse than what may have previously existed, in line with Approved Document M of the Building Regulations.
- 9.13 The design of routes around buildings should be clear and free from obstruction, especially to the entrance. Any obstructions should be made clear and avoidable, for example by changes in surface texture.
- 9.14 The above access principles apply mainly to non-residential developments – although the first two will also be applicable to residential developments. In the case of residential development, proposals must meet Lifetime Home Standards as set out in policy *DP6 – Lifetime Homes and wheelchair homes* of the Camden Development Policies. Reference should also be made to Camden Planning Guidance 2 and the section on Lifetime Homes and wheelchair housing.

### Design and Access Statements

- 9.15 A Design and Access Statement is a short written and illustrated report which accompanies and supports a planning application. It explains the thinking behind a design and its context in a proposal in a structured way. A Design and Access Statement should:
- Show how the applicant has analysed the site, its setting, and as a result of this assessment, formulated and applied design principles to achieve a good, inclusive design for buildings and public spaces;
  - Include the specific needs of disabled people, by showing how they have been integrated into the proposed development, and how inclusion will be maintained and managed; and
  - Be flexible, adaptable and be able to change with the design of the proposal should any amendments or changes occur.
- 9.16 The level of detail appropriate in an access statement will depend on the size, nature and complexity of the proposal, as a minimum, all should include:
- A short illustrated statement setting out the site and context appraisal, the purpose of the proposed development, a list of design principles and a description of the proposal explaining how the design responds to the appraisal and design principles;
  - A plan of the site, surrounding area or natural form and key features as identified in the appraisal;
  - Annotated sketches and photographs;
  - Important elements of the context that inform the design principles;
  - Plans and elevations of the proposal;
- 9.17 The following points should be taken into account when preparing a Design and Access statement:

- A brief explanation of the applicant's approach to access, with particular reference to the inclusion of disabled people;
- A description of how the sources of advice on accessibility and technical issues will be, or have been, followed;
- Details of any consultations undertaken or planned, including the number of users, particular user need groups (for example, visually impaired, deaf or hard of hearing, ethnic groups, people with learning disabilities and mental health) and the degree to which the process has been influenced by it;
- Details of any professional advice that has been followed, or will be sought, including recommendations from access audits or appraisals;
- An explanation of any specific issues affecting accessibility to, or within, the particular environment being considered, and/or service provision, employment or educational opportunities.
- Details of access solutions adopted to overcome any issues, including those which deviate from recognised good practice;
- Details of the management and maintenance practices adopted, or to be adopted, to maintain features enhancing accessibility (for example, lighting, colour and luminance contrast, door closing forces etc), specialist equipment (for example, induction loops, audible and visual fire alarm systems etc), and staff training; and
- A plan illustrating features such as routes in, out and around the outside of the building, vertical and horizontal circulation routes, positions of accessible car parking bays, the location of public transport, and any other features relevant to the proposal.

9.18 Where good practice cannot be met, the Access Statement should say why this is the case, set out the implications for users, and explain what other measures are being taken to ensure access is provided to the facilities available. See Further Information at the end of this section for links to more detailed guidance.

### **Listed buildings**

- 9.19 Design and access statements are also required for a listed building consent. Where a planning application is submitted in parallel with an application for listed building consent a single combined statement can be submitted which should address the requirements for both.
- 9.20 Measures to facilitate dignified and easy access to and within listed buildings can often be sensitively incorporated without damage to their special architectural or historic interest. However, the Disability Discrimination Act 1995 does not override other legislation such as listed building or planning legislation. Listed Building Consent will almost always be required for works to improve access and in formulating proposals; applicants are encouraged to undertake early discussions with the Council.

- 9.21 English Heritage has produced guidance on this topic titled Easy Access to Historic Buildings (see Further Information for the link). Additional information is also contained in Circular 01/06.

**Other considerations**

- 9.22 Applicants should note that Design and Access Statements differ from the requirements for Access statements set out in Approved Document M of the Building Regulations, which are only required when specific building control regulations can not be met. Approved Document M of the Building Regulations sets out the requirements to ensure access to and use of a building's facilities are accessible to all.
- 9.23 It may also be appropriate to combine the Design and Access Statements with other statements requested in other sections of Camden Planning Guidance, provided that the requirements of all such statements are adequately addressed.
- 9.24 Part 3 of the Disability Discrimination Act 1995 gives disabled people a right of access to goods, facilities and services. This requires service providers to:
- Alter a barrier feature so that it no longer has effect;
  - Provide a reasonable means of avoiding that feature; or
  - Provide a reasonable alternative method of making the service available.
- 9.25 These requirements apply to all buildings where services are provided to the public and to transportation infrastructure.



## Further information

Design and Access Statements	<p>Department for Communities and Local Government (March 2010) Guidance on information requirements and validation:  <a href="http://www.communities.gov.uk/publications/planningandbuilding/validationguidance">www.communities.gov.uk/publications/planningandbuilding/validationguidance</a></p> <p>ODPM publication: Planning and Access for Disabled People: A Good Practice Guide  <a href="http://www.communities.gov.uk/publications/planningandbuilding/planningaccess">www.communities.gov.uk/publications/planningandbuilding/planningaccess</a></p> <p>Department for Communities and Local Government Circular 01/2006: Guidance on Changes to the Development Control System: Section 3 provides guidance on the legislative position and information required  <a href="http://www.communities.gov.uk/publications/planningandbuilding/circularcommunities2">www.communities.gov.uk/publications/planningandbuilding/circularcommunities2</a></p> <p>The Commission for Architecture and the Built Environment (CABE) 'Design and access statements: how to write, read and use them'  <a href="http://www.cabe.org.uk">www.cabe.org.uk</a></p> <p>Mayor of London's Supplementary Planning Guidance: Accessible London: Achieving an Inclusive Environment  <a href="http://legacy.london.gov.uk/mayor/strategies/sds/docs/spg_accessible_london.pdf">http://legacy.london.gov.uk/mayor/strategies/sds/docs/spg_accessible_london.pdf</a></p>
Access and the historic environment	<p>English Heritage have published guidance on 'Easy Access to Historic Landscapes' and 'Easy Access to Historic Buildings' which can be found on their website at:  <a href="http://www.english-heritage.org.uk/publications/easy-access-to-historic-buildings/">www.english-heritage.org.uk/publications/easy-access-to-historic-buildings/</a></p>
Lifetime Homes and wheelchair housing standards	<p>Lifetime Homes  <a href="http://www.lifetimehomes.org.uk">www.lifetimehomes.org.uk</a></p> <p>Accessible London: Achieving an Inclusive Environment, GLA (April 2004)</p>

## 11 Open space, outdoor sport and recreation facilities

### KEY MESSAGES:

- If your scheme is over a certain size it is expected to make a contribution towards the provision of public open space in the borough;
- Our priority is for the provision of public open space on-site, therefore it is important this is taken into account at the design stage of your scheme;
- Other forms of public open space contributions could be provision off-site or as a payment in lieu.

- 11.1 This guidance gives details of how the Council expects development to provide for a variety of public open space, outdoor sport and recreation facilities. It sets out:
- Which developments are expected to make provision for open space, outdoor sport and recreation opportunities;
  - The amount of open space we expect;
  - The type of open space and outdoor sport and recreation facilities we expect;
  - How we will calculate the open space expected for a specific development; and
  - The Council's priorities for how open space, outdoor sport and recreation facilities will be provided.

- 11.2 This guidance primarily relates to:

#### Core Strategy Policies:

- CS5 – Managing the impact of growth
- CS15 – Protecting and improving our parks and open spaces and encouraging biodiversity

#### Development Policies:

- DP26 – Managing the impact of development on occupiers and neighbours
- DP31 – Provision of, and improvements to, open space and outdoor sport and recreation facilities.

### **Which developments are expected to contribute towards open space, outdoor sport and recreation facilities?**

- 11.3 As set out in paragraph 31.6 the Camden Development Policies document you will need to make a contribution to the provision of these facilities in the borough if your development falls within the following categories:

- Five or more additional dwellings;
- Student housing schemes creating an additional 10 or more units/rooms or occupiers; and
- Developments of 500sq m or more of any floorspace that are likely to increase the resident, worker or visitor populations of the borough.



### How much open space do we expect?

- 11.4 Development Policy *DP31 – Provision of, and improvements to, open space and outdoor sport and recreation facilities* sets out the amount of open space to be provided by developments as follows:

**Figure 2. Amount of open space to be provided by land use**

Development type	Open space provision
Residential (all types)	9 sq m per occupier
Commercial development	0.74 sq m per worker

- 11.5 Non-residential developments for higher education are considered to generate requirements per occupier (including employees and students) at the same rate as commercial developments.

### What types of open space, outdoor sport and recreation facilities will we expect?

- 11.6 Open space standards relate specifically to public open space. The Council acknowledges the private amenity space and other private open land can reduce pressure on the use of public open space. However public open spaces provide opportunities for social interaction and a focus for community activities. Private spaces cannot be used as a substitute for public open space.

- 11.7 Public open space includes a wide variety of different facilities that are available to the public:
- Green amenity spaces, including natural and semi-natural spaces;
  - Active spaces for outdoor sport and recreation and for children’s play; and
  - Civic spaces.
- 11.8 Green amenity spaces can be formal or informal parks and gardens or other landscaped areas, which provide areas of passive recreation for all age groups and attractive green areas within the urban environment. They are intended to be attractive spaces for people to enjoy using or viewing. This type of open space can include areas of natural or semi-natural green spaces, which support wildlife conservation and biodiversity and promote environmental education and awareness.
- 11.9 Active spaces are areas of grassed or artificial surfaces providing opportunities for sport and recreation together with ancillary facilities such as changing rooms and flood lighting. These include playing pitches, courts, greens, athletic tracks and Multi Use Games Areas (MUGAs). Formal recreation areas may be stand-alone facilities or may form part of a larger open space (e.g. the tennis courts and bowling greens at Hampstead Heath).
- 11.10 Civic spaces are hard surfaced areas designed for pedestrians, such as piazzas, which often provide a setting for civic buildings.
- 11.11 Given the amount of hard surfaces in Camden, our priority will generally be for green spaces, especially in the south of the borough. Paragraphs 11.12 to 11.17 give more details of specific types of public open space.

### **Children’s play space and young people’s recreation space**

- 11.12 These are formal or informal areas designed to engage children or young people. Formal spaces are designated areas for children and young people containing a range of facilities and an environment that has been designed to provide focused opportunities for outdoor play. There are three categories of formal children’s play space defined by the National Playing Fields Association (NPFA).
1. LAP - Local Area for Play;
  2. LEAP - Local Equipped Area for Play;
  3. NEAP - Neighbourhood Equipped Area for Play.
- 11.13 Informal spaces are less well defined areas and can be incorporated into smaller spaces such as local footpaths where wide enough or town centre spaces. It involves incorporating features that children can play with such as fountains or objects to climb.
- 11.14 Contributions to children’s play space and young people’s recreation space can include formal and informal areas. We must be satisfied that any informal space has been sufficiently designed to meet the requirements of children and young people.

### **Natural and semi-natural green spaces**

- 11.15 These include sites and areas formally recognised for their nature conservation value such as Sites of Special Scientific Interest, Sites of Nature Conservation Importance and Local Nature Reserves as well as other areas with biodiversity such as gardens, parks and open spaces.
- 11.16 In exceptional circumstance, generally in areas deficient in nature conservation sites, we may consider the inclusion of a biodiverse green roof, brown roof or green wall as a contribution towards natural and semi-natural green spaces in the borough. For more information about areas of deficiency please see Appendix A to this section. For more information about green roofs, brown roof and green walls please see Camden Planning Guidance 3 – Sustainability.

### **Allotments and Community Gardens**

- 11.17 Allotments and community gardens provide opportunities for people to grow food as part of the long term promotion of sustainability, health and social inclusion.

### **What type of open space, outdoor sport and recreation facilities are expected for specific development types?**

- 11.18 For this guidance, and in line with *Camden's Open space, Sport and Recreation Study Update 2008* we have identified the following five broad categories of open space:
- Public amenity open space;
  - Children's play space and young people's recreation space;
  - Natural and semi-natural green space;
  - Allotments and community gardens; and
  - Outdoor sport and recreation.
- 11.19 We recognise that not every type of development will generate a need for all types of open space, outdoor sport and recreation facilities. For example, housing for older people will not generate demand for children's play space. Figure 3 sets out the types of open space that are likely to be needed for various types of development.

**Figure 3. Type of open space to be provided by development**

	Amenity open space	Children's playspace	Natural green-space	Outdoor sport facilities	Allotments / Community gardens
Self-contained homes (Use Class C3)	✓	✓	✓	✓	✓
Student housing	✓	x	✓	✓	x
Housing for older people	✓	x	✓	x	✓
Commercial	✓	x	✓	✓	x

Source: adapted from Camden Open Space, Sport and Recreation Study Update 2008.

- 11.20 The requirement for 9 sq m of public open space per residential occupier and 0.74 sq m of public open space per employee/ student (commercial/ higher education developments) should generally be divided into different types of open space approximately as set out in Figure 4.
- 11.21 In Camden the potential to add to outdoor sports facilities for adults is limited. Provision for outdoor sports will be sought within the overall requirement of 9 sq m per residential occupier where an opportunity for provision arises. Where a development provides public facilities for outdoor sports these will reduce the requirement for other types of open space.
- 11.22 The Camden Open Space, Sport and Recreation Study Update 2008 derived a separate standard for allotments of 0.9 sq per residential occupier. The study indicated that additional space to grow food could only be provided by taking a flexible approach including community gardens, roof gardens, temporary use of vacant sites and converting parts of existing open spaces. Although the standard is not included within the 9 sq m overall requirement, paragraph 31.7 of the Camden Development Policies document indicates that allotments and community gardens are a Council priority. Provision will be sought wherever an opportunity arises, and will be considered to reduce the requirement for other types of open space.

**Figure 4. Break down of open space by type of provision  
Residential Developments (all types)**

Type of open space	Provision per adult	Provision per child
Amenity open space	5 sq m	4 sq m
Children's playspace (where applicable)		2.5sq m
Natural green space	4 sq m	2.5 sq m

**Commercial / higher education (non-residential)**

Type of open space	Provision
Amenity open space	0.4 sq m per person
Natural green space	0.34 sq m per person

**How we will calculate the open space expected for a specific development**

- 11.23 Figure 5 below shows the figures we will use to assess open space requirements for individual residential, commercial and higher education developments. The figures are based on the break down of open space requirements in Figure 4 and the occupancy rates recommended by the Camden Open Space, Sport and Recreation Study Update 2008. The occupancy rates are given in Appendix B to this section.

**Figure 5. Open space required for specific developments**

Self-contained homes in Use Class C3	Amenity open space	Children's play space	Natural green space	Total
One bedroom home	6.5 sq m		5.2 sq m	11.7 sq m
Two bedroom home	9.2 sq m	0.6 sq m	7.2 sq m	17.0 sq m
Three bedroom home	12.8 sq m	2.9 sq m	9.5 sq m	25.2 sq m
Four bedroom home	14.1 sq m	3.6 sq m	10.2 sq m	27.9 sq m
<b>Student housing, hotels and hostels</b>				
Single room	5.0 sq m		4.0 sq m	9.0 sq m
Double room	10.0 sq m		8.0 sq m	18.0 sq m
<b>Commercial/ higher education development</b>				
Per 1,000 sq m gross external area	21.6 sq m		17.9 sq m	38.9 sq m

- 11.24 Appendix D sets our worked examples showing the open space required for a number of different development types and sizes.

## **How public open space will be provided**

11.25 There are three ways in which you can make a contribution to public open space in Camden:

1. On site provision of new public open space;
2. Off site provision of new public open space;
3. Providing a financial contribution in lieu of direct provision.

### **On site provision of new public open space**

11.26 If your development is located in an area deficient in public open space or with an under provision of public open space we expect provision of new public open space on the development site (see Appendix A to this section and Core Strategy Map 7). This is in accordance with paragraph 31.7 of the Camden Development Policies document. Paragraph 31.7 and accompanying Table 1 also set out other developments that are expected to provide open space on-site. Some on-site provision is expected for residential development adding 60 or more homes and commercial development adding 30,000 sq m or more.

11.27 The amount and type of public open space that can be achieved on-site will be determined by the size of the site. Where children's play facilities are required as a result of the development, priority should be given to the provision of these facilities. On sites already covered by development, and where appropriate access may have to be restricted to the occupiers of the building, the provision of a roof garden as a contribution to public open space may be considered. If a roof garden is to be considered as public open space, as a minimum it should be able to be used by all the occupants of the building.

11.28 Any new public open space that is provided as part of your development should be:

- Large enough to cater effectively for the intended users;
- Designed to be fully accessible, where possible;
- Designed in consultation with the Council's Open space team; and
- Practical to maintain.

11.29 Where you are required to make a contribution to public open space we will ensure that the type of open space you provide best meets the needs of the occupiers or users of the development. You should consider designing your open space carefully to enable different types of open space to be located together or adjacent to each other to complement the overall provision of open space, sport and recreation opportunities.

11.30 We will expect new open space provision to be publicly accessible, however in exceptional circumstances, for example where an existing open space is in private ownership or already has restricted access we may accept an alternative access arrangement.



### **Off site provision of new public open space**

- 11.31 Where a site cannot provide public open space on-site, the preferred option will be provision of new suitable open space off-site. Once again this is especially important where a site does not have access to existing open space in accordance with the distance thresholds (see Appendix A to this section). The new provision should be within the distance threshold for the type of public open space to be provided. For example, if a developer is to provide a children's play area of 100 sq m this should be provided within 50 m walking distance of the development, if amenity open space is to be provided, this should be a maximum of 280 m from the development. If the developer is to provide for a new formal recreation area such as a multi-use games area, this should be provided within 1,200 m of the development.
- 11.32 We will accept the provision of public access to an existing open space that currently has restricted access as a contribution to off-site public open space provision.

### **Providing a financial contribution in lieu of direct provision**

- 11.33 The Council may agree to accept financial contributions in place of direct provision of new public open space where the development site is too small to incorporate on-site open space and the densely built up character of Camden prevents direct provision of off-site public open space. Financial contributions may be used for:
- The creation of an area of public open space, including buying additional land or leasing it at a nominal rate;
  - Improving access to existing public open space;
  - Opening up access to existing private open space;
  - Fit out of a new or existing open space, or some elements of the open space; and
  - Qualitative improvements to existing open space.
- 11.34 Financial contributions may be pooled to create, fit out, improve or provide access to open space. For example, where the Site Allocations Document indicates that new public open space is required on a development site, contributions from other developments within 280 m may be pooled to facilitate the creation of the new public open space.
- 11.35 Financial contributions are calculated on the basis of the costs and requirements set out in Figure 6.. We will aim to spend the collective amount in the proportions set out in Figure 6 and within the same ward as the contributing development where possible. However individual financial contributions will be spent on priorities identified in:
- Camden's open space, sport and recreation study update 2008;
  - Camden's open space strategy;
  - Camden's biodiversity action plan;
  - Camden's play strategy;
  - Camden's sport strategy;

- Individual park management plans.

11.36 A financial contribution is based on the:

- Capital cost of providing new public open space;
- Cost of maintenance for the first 5 years; and
- Cost for the open space team to administer the contribution and design schemes.

**Figure 6. The financial contributions**

	<b>Capital cost</b>	<b>Maintenance</b>	<b>Design and admin</b>
<b>Self-contained homes in Use Class C3</b>			
One bedroom home	£385	£386	£46
Two bedroom home	£663	£561	£80
Three bedroom home	£1,326	£832	£159
Four bedroom home	£1,537	£921	£184
<b>Student housing, hotels and hostels</b>			
Single room	£297	£297	£37
Double room	£593	£594	£71
<b>Commercial/ higher education development</b>			
Per 1,000 sq m	£1,265	£1,284	£152

- 11.37 These aggregate contributions are based on provision of public open space, natural green space and (where applicable) children's play space. Specific contributions to allotments and community gardens and to outdoor sport and recreation provision will be sought on a case by case basis depending on whether there are opportunities to add to provision or are local facilities that need to be maintained.
- 11.38 The calculation of the aggregate contributions is set out in Appendix C to this section. Appendix C includes break down of the capital cost by open space type. This may be needed for developments where a proportion of the open space requirement is met on site or where adequate open space of some types is already available locally.
- 11.39 Payments for maintenance and design and administration are explained in paragraphs 11.45 to 11.50. They have not been aggregated with capital costs as payments will sometimes be required need to be calculated separately (eg where open space will be provided by the developer but maintained by the Council. The Council may also wish to draw separately on funds for capital works, funds for maintenance and funds for design and administration.
- 11.40 The contributions may be adjusted upwards or downwards according to the particular circumstances of the development. They provide a starting

point for negotiations between the Council and developers. The scale of financial contributions will be reviewed and updated as appropriate.

- 11.41 Appendix D to this section sets out worked examples showing the contributions required for a number of different development types and sizes.

### **Providing a combination of open space provisions**

- 11.42 Your development may contribute to public open space through one of the ways listed above or by a combination of them. To determine the amount and type of public open space you are expected to provide, either on-site or off-site we will consider the:

- Type and size of the existing public open space provision within the distance threshold of your development; and
- Size and likely users of your development.

- 11.43 For example, if you propose a residential development located within 280 m of a small local park you may not be required to contribute to amenity open space, but may still be required to contribute to children's play facilities or a formal recreation area if suitable facilities do not exist within the distance threshold of the development.

- 11.44 In all cases a legal agreement will be required to secure the ongoing use of the open space provided as public open space, or to secure the financial contribution in lieu of direct provision.

### **Maintenance**

#### **On or off-site provision**

- 11.45 Where you provide a contribution towards public open space outdoor sport or recreation facilities (either on-site or off-site), the Council will need to be satisfied that it has been properly laid out and completed and that suitable contractual arrangements for its long-term maintenance have been put in place. If you provide new public open space (either on-site or off-site) you will be expected to transfer the space to the Council to maintain and retain for such use.

- 11.46 Where your new public open space is to be transferred to us, you will normally be required to remain responsible for its maintenance for an initial establishment period of 5 years. After this time, we will take full responsibility for the maintenance of that public open space.

#### **Financial contribution**

- 11.47 If you make a financial contribution in lieu of direct provision, whether it is for substantial qualitative or accessibility improvements to existing sites already maintained by the Council or for the provision of a new public open space, we will expect you to provide a commuted sum for the maintenance of these facilities for a period of five years.
- 11.48 Where your new public open space is not to be transferred to the Council a commuted sum for maintenance will not be required. However,

if you choose to retain control of your public open space, we will need to be sure that adequate provision for the maintenance and access of that public open space is in place.

- 11.49 In ALL cases a legal agreement will be required to secure the maintenance of public open space over a defined period or to secure the financial contribution in lieu of direct maintenance.

### **Design and administration**

- 11.50 For payments in lieu of providing public open space, on-site or off-site payments we will also require a 12% contribution towards the costs of our open space team to administer the financial contribution and to plan and design works within our open spaces.

### **Further information**

Open Space, Sport And Recreation Study	Camden's open space, sport and recreation study update 2008 provides an assessment of open space, sport and recreation provision and demand in the borough. <a href="http://www.camden.gov.uk/planning">www.camden.gov.uk/planning</a>
Biodiversity Action Plan	Camden's Biodiversity Action Plan provides Camden's priorities for improving our greenspaces and biodiversity. <a href="http://www.ukbap-reporting.org.uk/plans/lbap.asp">www.ukbap-reporting.org.uk/plans/lbap.asp</a>
PPS17	Planning Policy Guidance 17 – Planning for open space and its companion guide provide policy and guidance for the provision of open space including the quantitative and qualitative considerations. <a href="http://www.communities.gov.uk">www.communities.gov.uk</a>
Mayor of London's Supplementary Planning Guidance	The Mayor of London's Supplementary Planning Guidance Providing for children and young people's play and informal recreation provides guidance and examples of how to incorporate space for children and young people. <a href="http://legacy.london.gov.uk/">http://legacy.london.gov.uk/</a>

## Appendix A

### Public Open Space Deficiency

Figure 7 shows the maximum distance that people can reasonably be expected to travel on a regular basis to use different types of open space. Amenity open space and children's play space should be available within easy walking distance of the development to which they relate. People are generally willing to travel further to use recreation areas providing outdoor sport facilities or to larger parks.

**Figure 7. Distance threshold for different types of public open space**

Type of public open space	Minimum size (where applicable)	Distance from development to public open space
Public amenity open space		280m*
Formal recreation area		1.2 km
<b>Play Space</b>		
LAP	100sq m	50m*
LEAP	400sq m	280m*
NEAP	1000sq m	500m*
Natural greenspace	Any	500m
Allotments and community gardens	Any	Any

\*This distance is the actual walking distance, taking into account local circumstances, such as the location of entrance gates, street patterns, the severance effects of railway lines or heavy traffic flows that could all reduce the accessibility of open spaces.

(Based on Guide to preparing Open Space Strategies: Best practice guidance of the London Plan, Mayor of London, 2002)

Camden Core Strategy Map 7 shows areas of the borough that are deficient in public open space.

#### AREAS DEFICIENT IN PUBLIC OPEN SPACE

Areas more than 280m walking distance away from a public open space with a multi-functional role, that is a space over 0.25ha (2,500sq m).

Core Strategy policy CS13 also refers to areas with an under-provision of open space. These are areas with access to open space, but the provision is not sufficient to meet the level of local need due to the number of children, dwelling density, and social disadvantage in the area. These are shown in Figure 4.4 of Camden's Open Space, Sport and Recreation Study Update.

Both components are needed to ensure that everyone is within an appropriate distance of public open space based upon their needs and to ensure that people are not prevented from accessing that open space as a result of prohibitive costs. Contributions to open space will be

encouraged within the distance thresholds for the particular type of open space to be provided.

Paragraph 15.18 of Camden's Core Strategy indicates that residents and visitors further than 1 km away from a metropolitan or borough Site of Nature Conservation Importance (SNCI) are considered to have poor access to the natural environment. Core Strategy Map 8 shows all areas greater than 500 m from an SNCI as deficient in access to nature conservation areas.

#### **AREAS DEFICIENT IN NATURE CONSERVATION SITES**

Areas more than 500m walking distance away from a Borough or Metropolitan level Site of Nature Conservation Interest.

## Appendix B

### Occupancy rate by development type

The Camden Open Space, Sport and Recreation Study Update 2008 recommends calculating occupancy rates and child yields on the basis of the London Housing Survey 2002 and DMAG briefing 2005/25. The occupancy rates are shown in Figure 8.

**Figure 8. Occupancy rate for C3 homes based on the London Housing Survey and DMAG briefing 2005/25**

<b>Self-contained homes in Use Class C3</b>	<b>Total persons</b>	<b>Children (average)</b>	<b>Adults (net)</b>
One bedroom home	1.3	0.04*	1.3
Two bedroom home	1.9	0.25	1.65
Three bedroom home	2.8	1.15	1.65
Four bedroom home	3.1	1.44	1.66

Source: Camden Open Space, Sport and Recreation Study Update 2008.

\*The average child yield for a one bedroom home equates to 1 child per 25 homes, which would not generate a meaningful play space requirement, and has been treated as 0.

Occupancy rates for student housing, hotels and hostels are assumed to be one person per single bedroom and two people per double bedroom.

The study recommends assuming an employee density of one worker per 19 sq m (gross external area) for commercial floorspace. This generates an occupancy rate of 52.6 employees per 1,000 sq m (gross external area). Non-residential developments for higher education are considered to generate the same number of occupants (including employees and students) as commercial developments.

## Appendix C

### Calculation of financial contributions

This appendix shows how we have calculated the financial contributions for provision or enhancement of public open space.

In addition to this capital cost, you will be expected to pay a commuted sum to cover:

- Maintenance of the facility and open space provision over a 5 year period; and
- Designing the new open space works and administering the financial contribution by Camden's open space team.

**Figure 9. Capital cost of provision**

Type of public open space	Capital cost
Amenity open space	£46.22 per sq m
Children's play space and young people's recreation space	£199.48 per sq m
Natural and semi-natural greenspace	£16.42 per sq m
Allotments/Community Gardens	£32.50 per sq m

Source: Camden Open Space, Sport and Recreation Study Update 2008

Figure 5 sets out the break down of open space requirements for developments of specific sizes. The capital costs have been aggregated in accordance with Figure 5 as set out in Figure 10.



**Figure 10. Calculation of financial contribution to capital cost**

Capital cost per square metre	Amenity open space £46.22 psm	Children's play space £199.48 psm	Natural green space £16.42 psm	Total (amenity space + play space + green space)
<b>Self-contained homes in Use Class C3</b>				
One bedroom home: space required	6.5 sq m		5.2 sq m	
Space required x cost per square metre	£300		£85	£385
Two bedroom home: space required	9.2 sq m	0.6 sq m	7.2 sq m	
Space required x cost per square metre	£425	£120	£118	£663
Three bedroom home: space required	12.8 sq m	2.9 sq m	9.5 sq m	
Space required x cost per square metre	£592	£578	£156	£1,326
Four bedroom home: space required	14.1 sq m	3.6 sq m	10.2 sq m	
Space required x cost per square metre	£652	£718	£167	£1,537
<b>Student housing, hotels and hostels</b>				
Single room: space required	5 sq m		4 sq m	
Space required x cost per square metre	£231		£66	£297
Double room: space required	10 sq m		8 sq m	
Space required x cost per square metre	£462		£131	£593
<b>Commercial/ higher education development</b>				
Space required per 1,000 sq m	21.0 sq m		17.9 sq m	
Space required x cost per square metre	£971		£294	£1,265

### Contributions to maintenance costs

In addition to capital costs, the Council has established a maintenance cost of £6.60 per square metre per year, based on the 2006 Parks and Open Spaces Budget, plus inflation.

The standard length of time developers should provide for maintenance of new and enhanced public open space is 5 years.

Commuted sums for maintenance of public open space are calculated as follows: open space requirement (sq m) x £6.60 x 5. This equates to £33 per square metre of open space required.

### Contributions to the cost of design and administration

Design and administration costs have been assessed as 12% of the capital cost of the open space provision or contribution.

## Appendix D

### Worked Examples

#### Worked Example 1:

##### Public open space provision for self-contained homes (C3)

A residential development of 16 new homes provides the following mix of dwelling sizes: 3 x 1-bedroom, 8 x 2-bedroom, 4 x 3-bedroom and 1 x 4-bedroom. The open space requirement can be calculated as follows:

Home size	No of homes	x open space requirement per home (sq m) from Figure 5	= total requirement (sq m)
One bedroom home	3	11.7	35.1
Two bedroom home	8	17.0	136.0
Three bedroom home	4	25.2	100.8
Four bedroom home	1	27.9	27.9
Total for all homes	16		299.8

The total open space requirement for this 16 home scheme would be approximately 300 sq m.

#### Worked Example 2:

##### Public open space provision for non-residential development

An office development provides 1,500sq m of additional floorspace. The open space requirement can be calculated as follows:

Additional floorspace	÷ 1,000 to give floorspace in thousands of sq m	x open space requirement per 1,000 sq m from Figure 5	= total requirement (sq m)
1,500 sq m	1.5	38.9	58.35

The total open space requirement for this additional non-residential floorspace would be approximately 60 sq m.

#### Worked Example 3:

##### Payment in lieu of open space provision for non-residential development – capital costs

As per example 2, an office development provides 1,500 sq m of additional floorspace. The payment in lieu of open space provision can be calculated as follows:

<b>Additional floorspace</b>	<b>÷ 1,000 to give floorspace in thousands of sq m</b>	<b>x capital cost per 1,000 sq m from Figure 6</b>	<b>= total payment for capital costs</b>
1,500 sq m	1.5	£1,265	£1,897.50

The payment in lieu of open space provision for this additional non-residential floorspace based on capital costs would be £1,897.50. However, we would also expect payments towards maintenance and design and administration – see example 5.

#### **Worked Example 4**

##### **Payment in lieu of open space provision for student housing – capital costs**

A student housing scheme provides 30 single rooms and 10 double rooms. The payment in lieu of open space provision can be calculated as follows:

<b>Bedroom type</b>	<b>No of bedrooms</b>	<b>x capital cost per bedroom from Figure 6</b>	<b>= total payment for capital costs</b>
Single	30	£297	£8,910
Double	10	£593	£5,930
Total for all bedrooms	40		£14,840

The payment in lieu of open space provision for this student housing based on capital costs would be £14,840. However, we would also expect payments towards maintenance and design and administration – see example 5.

#### **Worked Example 5**

##### **Payment in lieu of open space provision for self-contained homes (C3) – all costs**

A residential development of 5 new homes provides the following mix of dwelling sizes: 1 x 1-bedroom, 3 x 2-bedroom, 1 x 3-bedrooms. The total payment in lieu of open space provision can be calculated in 4 stages

**Stage 1 – Capital costs**

Home size	No of homes	x capital cost per home from Figure 6	= total payment for capital costs
One bedroom home	1	£385	£385
Two bedroom home	3	£663	£1,989
Three bedroom home	1	£1,326	£1,326
Total for all homes	5		£3,700

The payment in lieu of open space provision for this 5 home scheme based on capital costs would be £3,700.

**Stage 2 – Maintenance costs**

Home size	No of homes	x maintenance cost per unit from Figure 6	= total payment for maintenance
One bedroom home	1	£386	£386
Two bedroom home	3	£561	£1,683
Three bedroom home	1	£832	£832
Total for all homes	5		£2,901

The payment in lieu to cover maintenance of new or enhanced open space for this 5 home scheme would be £2,901.

**Stage 3 – Design and administration costs**

Home size	No of homes	x design and administration cost per unit from Figure 6	= total payment for design and administration
One bedroom home	1	£46	£46
Two bedroom home	3	£80	£240
Three bedroom home	1	£159	£159
Total for all homes	5		£445

The payment in lieu to design and administration for new or enhanced open space for this 5 home scheme would be £445.

**Stage 4 – Sum of all costs**

The three separate types of costs will not usually be aggregated for the Council's purposes (see paragraph 11.39). However, for the guidance of developers, the three costs can be added together.

In this example, the total cost to the developer would be:

Capital costs	£3,700
+ maintenance costs	£2,901
+ design and administration costs	£445
<b>= grand total</b>	<b>£7,046</b>

Camden Planning Guidance

# Transport

London Borough of Camden

CPG 7

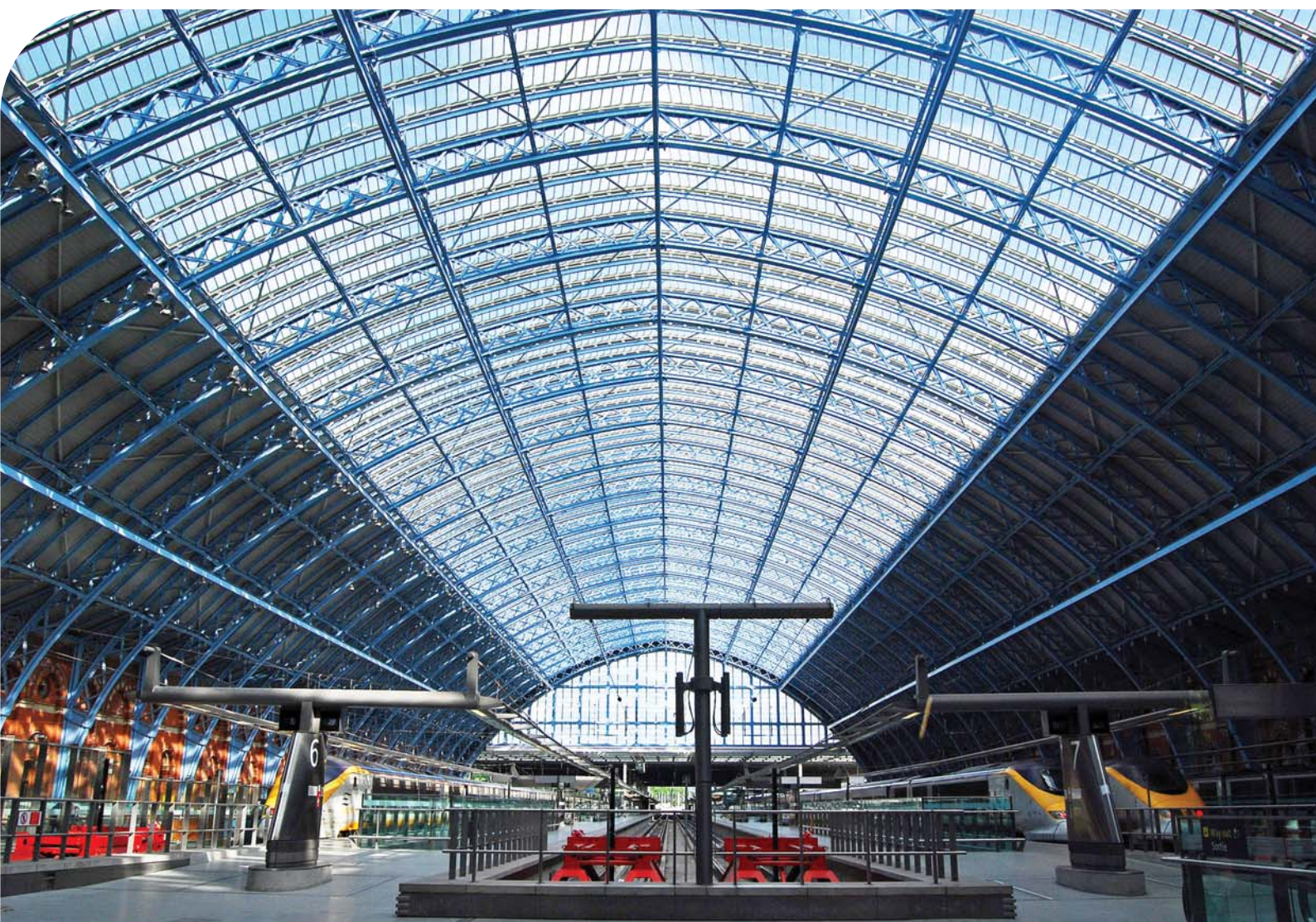

## CPG7 Transport

1	Introduction .....	5
2	Assessing transport capacity .....	7
3	Travel plans.....	13
4	Delivery and servicing management plans .....	21
5	Car free and car capped development.....	25
6	On-site car parking.....	29
7	Vehicle access .....	35
8	Streets and public spaces .....	41
9	Cycling facilities.....	47
10	Minicab offices .....	56

**Index**

Car clubs .....	31	Electric charging points .....	32
Car free and car capped development.....	25	Legible London .....	45
Car parking (on-site).....	29	Minicab offices .....	56
Cycle hire scheme.....	49	Servicing management plans .....	21
Cycle parking.....	47	Street furniture .....	44
Cycle stations .....	50	Streets and public spaces .....	41
Cycling facilities.....	47	Transport Assessments.....	7, 8
Disabled (parking) .....	28	Travel plans .....	13
		Vehicle access.....	35



Strategic Planning and Information  
London Borough of Camden  
Town Hall Extension, Argyle Street  
London WC1H 8EQ  
Tel: 020 7974 2043 / 2519  
Fax: 020 7974 1930  
Email: [ldf@camden.gov.uk](mailto:ldf@camden.gov.uk)  
[www.camden.gov.uk](http://www.camden.gov.uk)

# 1 Introduction

## What is Camden Planning Guidance?

- 1.1 We have prepared this Camden Planning Guidance to support the policies in our Local Development Framework (LDF). This guidance is therefore consistent with the Core Strategy and the Development Policies, and forms a Supplementary Planning Document (SPD) which is an additional “material consideration” in planning decisions. This new guidance will replace the Camden Planning Guidance 2006, updating advice where appropriate and providing new guidance on matters introduced or strengthened in the LDF.
- 1.2 The Camden Planning Guidance covers a range of topics (such as housing, sustainability, amenity and planning obligations) and so all of the sections should be read in conjunction, and within the context of Camden’s LDF.

## Transport in Camden

- 1.3 Camden benefits from excellent transport provision with international and national rail links, numerous tube stations and a large number of bus routes providing accessibility within Camden, to the rest of London and beyond. However, being a located in central London, the borough also faces considerable transport challenges, including congestion and poor air quality.

## What does this guidance cover?

- 1.4 This guidance provides information on all types of detailed transport issues within the borough and includes the following sections:
  1. Assessing transport capacity
  2. Travel Plans
  3. Delivery and Servicing Management Plans
  4. Car free and car capped development
  5. On-site car parking
  6. Vehicle access
  7. Streets and public spaces
  8. Cycling facilities
  9. Minicab offices
- 1.5 This guidance supports the following Local Development Framework policies:

## Core Strategy

- CS11 Promoting sustainable and efficient travel
- CS16 Improving Camden’s health and well-being

**Development Policies**

- DP16 The transport implications of development
- DP17 Walking, cycling and public transport
- DP18 Parking standards and limiting the availability of car parking
- DP19 Managing the impact of parking
- DP20 Movement of goods and materials
- DP21 Development connecting to the highway network
- DP32 Air quality and Camden's clear zone

## 4 Delivery and servicing management plans

### KEY MESSAGES

- Transport Assessments represent the best tool to consider how a development can most appropriately be serviced
- Developments should accord with the Servicing Guidelines provided in this guidance

- 4.1 The purpose of this guidance is to give details on how Delivery and Servicing Management Plans can be used to manage and mitigate the potential impacts of deliveries and servicing on the amenity of occupiers and neighbours.
- 4.2 This guidance relates to Core Strategy Policy CS5 - *Managing the impact of growth and development* and policies DP20 - *Movement of goods and materials*, and DP26 - *Managing the impact of development on occupiers and neighbours* of the Camden Development Policies

### When does this guidance apply?

- 4.3 This guidance applies to all development proposals which are likely to generate delivery and servicing movement and therefore may incur significant noise and disturbance impacts. Further details on the circumstances in which the Council will expect/require Delivery and Servicing Management Plans are set out within this guidance.

### How should Delivery and Servicing Management Plans be prepared?

#### Service vehicles and waste collection

- 4.4 General guidance on requirements for service vehicles and goods vehicles is given in Development Policy DP20 - *Movement of goods and materials*. Transport Assessments represent the best tool to consider how a development can most appropriately be serviced. Loading and unloading for some developments can safely and appropriately take place on-street, depending on the nature of the street and the development. Where a development is most appropriately serviced off-street, the application should show that the development will accord with the servicing guidelines shown in the table at the end of this section.
- 4.5 Guideline thresholds for the scale of development where a Transport Assessment will be required are given in LDF Development Policies Appendix 1. For development of significant floorspace in commercial use and residential institutions, the LDF proposes off-site bays for servicing, but also proposes a Transport Assessment that can test the appropriateness of alternative solutions.

- 4.6 For retail-type floorspace (Use Classes A1-A5), the guideline threshold is developments of 1,000 sq m or more. For other commercial floorspace, hotels, and institutional residential accommodation such as hotels, colleges and hostels, the guideline threshold is developments of 2,500 sq m or more. The transport characteristics of Use Classes D1-D2 (including surgeries, places of worship and cinemas) are too variable for any assumption to be made about the need for on-site servicing, but a Transport Assessment is sought in most cases.
- 4.7 The scale of a development is not the only factor controlling the servicing needs it generates. A Transport Assessment is required for any development that would significantly impact the transport system under policy DP16 of the Camden Development Policies. This could be expected to include, for example, any development serviced on-street and likely to receive more than 10 deliveries a day or 2 deliveries an hour. Assessment is also required for developments that generate a number of heavy vehicle movements (see the Assessing Transport Capacity section of this guidance).
- 4.8 If waste collection vehicles need to access a development site, this can be a key consideration in the design of motor vehicle access and circulation spaces. Information on the amount of space needed for sorting and storage of waste on-site prior to collection is given in the Waste recycling and storage section of CPG1 Design. The Council does not generally allow waste to be left on the highway for collection on a specified day except in the case of residential development of 6 dwellings or less.
- 4.9 External storage space for large waste containers is sought for residential development of 7 dwellings or more, and for most non-residential development. The external storage space should be at or near street level, and within 10 metres of a place suitable for a collection vehicle to stop. If appropriate external storage space for waste cannot be provided within 10 metres of the public highway, it will generally be necessary for the collection vehicle to access the development site. In this case, circulation spaces will need to be considered in the same way as those for service vehicles.

### Servicing Guidelines

Swept paths	Applicants should provide evidence of swept paths on submitted drawings.
Turning areas	Normally, all vehicles must be able to enter and leave the site in a forward facing direction. If in exceptional cases this is not possible, the service area must be designed to enable vehicles to reverse off the highway rather than onto it.
Demarcation	Servicing bays and turning areas should be clearly marked out, for example, by the use of different colours and materials, to discourage their misuse for car parking and storage.
Pedestrians	Care must be taken to provide safe segregated routes for use by pedestrians. Where access roads for service vehicles represent the most direct or visible route for pedestrians, a segregated footway at least 1.8 m in width should be provided with direct links to each pedestrian entrance of each building on site.
Access roads	A minimum carriageway-width of 6.0 m is required where an internal access is designed for two-way use by service vehicles. Where a footway is not provided to each side, a safety margin with a minimum width of 0.5m must be provided wherever there is no footway.
Headroom	A vertical clearance of 3.5m must be provided for light and medium goods vehicles.

### Further information

CPG1 Design, LB Camden 2011

Camden Streetscape Design Manual, LB Camden 2005

Camden Council transport strategies and plans, including the Streetscape Design Manual, can be viewed in the transport and streets section of the Council's website

Residential roads and footpaths: layout considerations - Design bulletin 32 (2nd edition), HMSO 1992 – this can be obtained via:

[www.tsoshop.co.uk/bookstore.asp](http://www.tsoshop.co.uk/bookstore.asp)

## 5 Car free and car capped development

### KEY MESSAGES

- We expect car free development in the borough's most accessible locations and where a development could lead to on-street parking problems
- Legal agreements will be used to maintain car-free and car-capped development over the lifetime of a scheme

- 5.1 This section explains further the terms car-free and car-capped development, as referred to in the Camden Core Strategy and Camden Development Policies, the mechanisms that are needed to secure them, and the circumstances in which it will be appropriate for the Council to refuse additional dwellings that are not car free or car capped.
- 5.2 It relates to Core Strategy Policy CS7 – *Promoting sustainable and efficient travel* and policies DP18 – *Parking standards and limiting the availability of parking* and DP19 - *Managing the impact of parking* of the Camden Development Policies.

#### **Car-free development**

A development which has no parking within the site and occupiers are not issued with on-street parking permits

#### **Car-capped development**

A development which has a limited amount of on-site car parking, but no access to on-street parking permits.

- 5.3 Car-free and car capped development is successful in Camden because most of the borough has very good access to public transport services. Levels of car ownership are low compared with London generally, and choosing not to own a car can be an attractive lifestyle option. The guidance in this section covers:
- What car free development is, and where it is sought;
  - What car capped development is, and where it is sought;
  - Implementation of off-street parking restrictions for car-free and car-capped development, including partial provision of car free and car capped development, and maintaining the on-street parking rights of existing occupiers;
  - Meeting the parking needs of disabled people.

### **When we expect car free and car capped housing**

- 5.4 Car free and car capped requirements apply to developments in particular locations and circumstances:
- we expect car free development in the Central London area, our town centres and other areas with high public transport accessibility (see Development Policy DP18);

- we will also expect car free development where the creation of a new access could lead to on-street parking problems where the loss of kerb space creates unacceptable parking pressure. Refer to Development Policy DP21, and the Access section of this guidance for more information);
  - Car capped development applies to schemes that would have an unacceptable impact on on-street parking conditions or highway management and safety through the introduction of new units with access to on-street parking permits (see Development Policy DP19).
- 5.5 Car-free or car-capped housing may be sought wherever development involves the creation of one or more additional dwellings – whether newly built, or created by a conversion or change-of-use.
- 5.6 Non-residential development can potentially involve car-free or car-capped designation if it creates a new non-residential address or involves a change-of-use that would otherwise increase the demand for car parking. This reflects the operation of the parking permit scheme, where permits relate to individual addresses.

### **Car free development**

- 5.7 Car-free development is development that does not have any car parking. No parking is provided or allowed on the site (except parking designated for disabled people), and all of the dwellings or units created are not entitled to on-street car parking permits. Where we seek car free development our parking standards do not apply as no parking is allowed.
- 5.8 Camden Development Policy DP18 states that we will expect development to be car free in the Central London Area, the town centres of Camden Town, Finchley Road/ Swiss Cottage, Kentish Town, Kilburn High Road and West Hampstead, and other highly accessible areas.
- 5.9 'Highly accessible areas' are considered to be areas with a public transport accessibility level (PTAL) of 4 and above. The PTAL of a specific site can be established using Transport for London's Planning Information Database website pages, which can be found at: <http://webpid.elgin.gov.uk/>.
- 5.10 Car free development will also be required where the creation of an access to allow off-street parking would reduce the availability of on-street parking (see also section 6 of this guidance on vehicle access), or would otherwise cause problems relating to highway management or safety. Policy DP19 of the Camden Development Policies states that we will resist developments that would harm on-street parking conditions or harm highway safety.

### **Car capped development**

- 5.11 Car-capped development is development in which all of the dwellings or units created are not entitled to on-street car parking permits, although some or all of the dwellings or units created may have a parking space



on the site, in accordance Camden's parking standards (see policy DP18 and Appendix 2 of the Camden Development Policies). It therefore differs from car free development because some on-site car parking is allowed, in line with Camden's parking standards.

- 5.12 Car capped development is sought in developments that are not in the locations listed in paragraph 4.7 above, where additional off-street spaces can be accommodated within the development without harming highway or on-street parking conditions, but where additional on-street car parking is not considered acceptable.

### **Circumstances where additional on-street car parking is not acceptable**

- 5.13 There are parts of the Borough where increasing competition for on-street parking through introducing additional premises with on-street parking rights is not acceptable. This is generally the case in the Central London Area, but also in many other areas where the parking spaces available cannot meet existing demand. This has implications for queuing and congestion, illegal parking, and highway safety. In these circumstances, if a developer will not enter into an agreement to designate the additional development as car-free or car-capped, planning permission will not be given.
- 5.14 In considering the ability of available on-street parking to accommodate the impact of additional development, we will have regard to the cumulative effect of proposals in the area, including unimplemented and partly implemented schemes already granted planning approval.
- 5.15 Our Parking and Enforcement Plan provides regularly updated permit data, which is used to establish levels of on-street parking pressure on each of the borough's roads. This information will be used when considering the acceptability of applications that would involve the potential allocation of additional on-street parking permits to the future occupiers of new development.

### **Implementation of on-street parking restrictions for car-free and car-capped development**

- 5.16 The whole of Camden has controlled parking and, in principle, is appropriate for car-free or car-capped development. On most days, most parking spaces on residential streets are only available to people holding a parking permit issued by the Council. In Controlled Parking Zones we can restrict access to on-street car parking because we can control the issuing of parking permits.

#### **Controlled Parking Zones**

Designated areas in regulations control how parking may be used on different sections of the street and at different times.

- 5.17 In order to be able to maintain car-free and car-capped development over the lifetime of a scheme, the developer will be required to enter into

a legal agreement under Section 106 of the Town and Country Planning Act 1990 (as amended), which would permanently remove the entitlement to an on street parking permit for each home created:

- 5.18 The legal agreement requires the owner of the development to inform incoming occupiers that they are not eligible to obtain a parking permit for on-street parking, or to purchase a space in a Council-controlled car park. This part of the legal agreement stays on the local search in perpetuity so that any future purchaser of the property is informed that occupiers are not eligible for parking permits.

### **Maintaining on-street parking rights of existing occupiers**

- 5.19 Existing parking rights can normally be retained on development sites, where it can be demonstrated that existing occupiers are to return to the address when it is completed. This is common where an existing dwelling or block is being extended or subdivided. It can also occur where a change-of-use brings a site or property into residential occupation.
- 5.20 If a development is to have new occupiers, existing parking rights will not apply, and the Council will apply its car-free / car-capped policies as set out in Development Policies DP18 and DP19.

### **Meeting the needs of disabled people**

- 5.21 Car-free development and car-capped development should be designed taking into account the needs of disabled car users. Blue Badge holders are able to use parking spaces in Controlled Parking Zones without a parking permit. Minimum parking standards apply to parking for people with disabilities, and 1 parking space for people with disabilities is required per 10 general-purpose dwellings (see Appendix 2 of the Camden Development Policies document). In addition, where car-free and car-capped developments contain wheelchair housing, the Council will expect a parking space to be provided for each wheelchair dwelling. Where a resident in need of a reserved disabled parking space moves into a development with no off-street spaces, the Council will consider a request for a designated disabled space on-street in the same way whether the development is formally car-free or not.

### **Further information**

- 5.22 In addition the guidance above regard should also be had to Camden's Parking and Enforcement Plan (2004), which provides further information on our approach to managing parking in the borough.

## 8 Streets and public spaces

### KEY MESSAGES

- New development should contribute to the creation of attractive, clean and well-maintained public places
- All new pedestrian areas and footpaths are required to be constructed to a standard that is considered appropriate for adoption by the relevant Highway Authority.

- 8.1 This section provides guidance on the design and layout of streets and public spaces. It aims to ensure that a good quality pedestrian environment and good pedestrian access are provided. This includes ensuring that development is accessible to all members of the community, including all disability groups.
- 8.2 The guidance relates to Camden Core Strategy Policy CS11 - *Promoting sustainable and efficient travel* and policies DP16 - *The transport implications of development* and DP17 - *Walking, cycling and public transport* and DP21 - *Development connecting to the highway network* in Camden Development Policies.

#### Public realm

All areas to which the public has open access.

#### Legible London scheme

A new signage scheme which aims simplify pedestrian movement around London.



- 8.3 This section includes guidance for the design and layout of streets and public spaces including:
- quality of the public realm;
  - ease of pedestrian movement;
  - street furniture;
  - footpaths that are not alongside roads,
  - our approach to shared surfaces; and
  - information on the Legible London scheme.

### **When does this apply?**

- 8.4 This guidance applies to planning applications that involve a change in the way that pedestrians access a site or move in and around the site, and also applications that change vehicle movements in a way that will affect pedestrians.
- 8.5 It should guide arrangements for pedestrians that arrive by car, public transport or bicycle, as well as those arriving on foot.

### **The design and layout of streets and public spaces**

#### **CAMDEN STREETSCAPE DESIGN MANUAL (2005)**

Provides useful guidance for those who are planning the design and layout of streets and public spaces. The manual sets out the Council's detailed expectations for street works in the borough, addressing issues such as responding to local character, footway design and materials, and street furniture.

### **General principles**

- 8.6 We will seek improvements to streets and spaces to ensure good quality access and circulation arrangements for all. This includes improvement to existing routes and footways that will serve the development. Key considerations informing the design streets and public spaces include the following:
- Camden Streetscape Design Manual;
  - ensuring the safety of vulnerable road users, including children, elderly people and people with mobility difficulties, sight impairments, and other disabilities;
  - maximising pedestrian accessibility and minimising journey times;
  - providing stretches of continuous public footways without public highway crossings;
  - linking to, maintaining, extending and improving the network of pedestrian pathways;
  - maximising pedestrian safety by providing adequate lighting and overlooking from adjacent buildings;
  - taking account of surrounding context and character of area

- providing a high quality environment in terms of appearance, design and construction, paying attention to Conservation Areas, and using traditional materials (such as natural stone or granite setts) where appropriate,
- use of paving surfaces which enhance ease of movement for vulnerable road users; and
- avoiding street clutter and minimising the risk of pedestrian routes being obstructed or narrowed, e.g. by pavement parking or by street furniture.

### **Ensuring high quality public spaces**

- 8.7 The Core Strategy seeks to ensure that new development contributes to the creation of attractive, clean and well-maintained public places (see Policy CS14). It is essential that new streets and public spaces integrate with surrounding spaces and links, and are designed and built to a high standard, including through the use of good quality materials. The government's Manual for Streets provides useful guidance on achieving successful public spaces, and Camden's Streetscape Design Manual sets out guidance on how to ensure works contribute to local character and distinctiveness.
- 8.8 Where developments generate the need for works to road, highways and adopted public spaces, these should be funded by the developer (see CPG8 Planning obligations for transport provision) but carried out by the council in order to ensure consistent high standards of implementation and materials in streets and public spaces. In line with policy DP21 of the Camden Development Policies, all new pedestrian areas and footpaths are required to be constructed to a standard that is considered appropriate for adoption by the relevant Highway Authority.

#### **Street clutter**

Excessive use of road signs, bollards and lampposts leading to an untidy street environment.

### **Ease of pedestrian movement**

- 8.9 Footways should be wide enough for two people using wheelchairs, or prams, to pass each other. We seek to maximise the width of footways wherever possible. The Camden Streetscape Design Manual sets out minimum widths for different kinds of footways.

#### **Wayfinding**

The process of navigating or defining a path through an environment.

- 8.10 Policy DP21 of the Camden Development Policies document states that we will expect works affecting highways to avoid unnecessary street clutter. Design of footways should not include projections into the footway, unnecessary and cluttered street furniture or other obstructions. Any minimum standards for footway widths should not be used to justify the provision of unnecessary street clutter or reduction in footway width.

The Council will generally resist proposals that involve the opening of doors into footways as they raise safety concerns, and can obstruct pedestrians.

- 8.11 Footways should be designed with frequent and convenient road crossing points for pedestrians. The detailed design of edges, crossings and gradients should take into account the need for the maintenance of minimum pavement widths, ease of movement and wayfinding, and appropriate measures for those with visual impairments and mobility difficulties. The Camden Streetscape Design Manual and DETR 'Guidance on the use of Tactile Paving Surfaces 1998' provide useful guidance which should be used to inform the design of edges, crossings and gradients.

#### **Tables and chairs**

- 8.12 The Council will sometimes licence the placing of tables and chairs on the footway in association with adjacent cafes and similar uses. The area where tables and chairs may be placed must be designated and must not interrupt the area of footway for pedestrian movement. The licence will specify permitted hours, after which the removal of tables and chairs will generally be required. Further guidance on tables and chairs is provided in CPG5 Town centres, retail and employment.

#### **Lighting, signage and street furniture**

- 8.13 Footways should be well lit and well signed, but with care to avoid light pollution and obstructions. Wherever possible, lighting and signs should be placed on buildings or existing street furniture to minimise footway clutter. Please also see paragraphs 7.17 to 7.22 on Legible London below.
- 8.14 The installation of seating, bus shelters, litter bins and cycle parking is encouraged in association with new footways provided that it will improve the pedestrian environment, and the use of sustainable modes of transport. However, they should be positioned so they do not interrupt the minimum area of footway designated for pedestrians. If possible, cycle stands (and cycles parked at them) should be wholly clear of the footway.

#### **Footpaths that are not alongside roads**

- 8.15 Footpaths independent of roads can be beneficial in terms of directly following the most direct routes for pedestrians and creating pleasant environments. However, great care is needed to provide security for pedestrians and discourage anti-social behaviour. Designs should consider:
- lighting;
  - natural overlooking from adjacent buildings;
  - maintaining visibility over the full stretch of the route between roads;
  - the appropriateness of planting; and

- avoiding features that could conceal assailants.

### **Pedestrian and vehicle shared surfaces**

- 8.16 Policy DP17 of the Camden Development Policies states that we will seek shared surfaces in appropriate circumstances and where it will be safe for all users. Safety and accessibility for all will be examined thoroughly in any shared surface proposal.

#### **Shared surface**

A highway where distinction between pedestrian and vehicle areas has been removed or reduced and sends a strong signal that the whole of the highway space is open equally to all users.

- 8.17 Where shared surfaces are used, a combination of other traffic management measures should also be used to reduce vehicle speeds to 5-10 mph. Measures to reduce vehicle speeds should not limit visibility for pedestrians and vehicles, and must not prejudice safety. Further measures to promote safety include
- the removal of parked vehicles from the shared surface to avoid potential conflicts with children at play; and
  - provision of clear routes and surface textures to assist orientation of people with visual impairments.

### **Legible London wayfinding signage**

- 8.18 Legible London was set up by Transport for London (TfL) in partnership with London boroughs to create a standard pedestrian wayfinding and signage system for central and inner London. It is a map-based system which gives users a good understanding of the surrounding area and encourages them to choose their own route to a specific destination.
- 8.19 Legible London signage is supported in Camden's Core Strategy Policy CS11 as a key element of Camden's approach to promoting walking in the borough. It has also been adopted by other London boroughs and thus provides consistent pedestrian signage across central and inner London.
- 8.20 The Legible London standard has been adopted by Camden and all new signs on the public highway should be of a Legible London type. The Council will also seek Legible London signage on private land, where appropriate.
- 8.21 TfL's Legible London programme currently covers the Central London area and we will extend the Legible London scheme throughout the borough, prioritising key destinations and busier areas, such as our town centres (see Core Strategy Policy CS11 paragraph 11.11). We will seek on-site provision of Legible London signage in these areas as appropriate, and on developments that contain:
- key routes to or through the site;

- decision points, arrival points and places where pedestrians are likely to gather;
  - complex spaces and areas outside civic spaces and public buildings.
- 8.22 Where relevant, sign types and quantities should tie into any relevant area strategies produced by the Council, in partnership with TfL.
- 8.23 As well as on-site provision, developments will also be expected to provide contributions to the Legible London in other locations, where appropriate, in order to mitigate the increased level of activity their development generates (see transport section of CPG8 Planning obligations).

#### **Highway authority approval**

- 8.24 Works to streets and public spaces also require separate approval from the relevant highway authority (usually Camden council). You are advised to contact our Highways department as soon as possible to discuss the approach to and proposed works to streets and public spaces.

#### **Further information**

- 8.25 In addition to Camden's Core Strategy, Development Policies, the Camden Streetscape Design Manual and other sections in this guidance, reference should be made to the following guidance:
- Manual for Streets, DfT, 2007
  - Residential roads and footpaths: layout considerations – DfT Design bulletin 32 (2nd edition), HMSO 1992
  - Guidance on the use of tactile paving surfaces, DETR 1998 - this can be viewed on the 'transport infrastructure, pedestrians, wheelchair and scooter users' pages in the 'access for disabled people' section of: [www.dft.gov.uk](http://www.dft.gov.uk)



## 9 Cycling facilities

### KEY MESSAGES

This section includes guidance on:

- The implementation of our minimum cycle parking standards for new development;
- The design and layout of cycle parking; and
- Cycle hire and cycle stations.

9.1 This section provides guidance on meeting cycle parking standards in an effective way, so that cycle parking is convenient and secure, and users of a development are more likely to use bicycles to travel to and from the site.

9.2 It relates to Core Strategy Policy CS11 – *Promoting sustainable and efficient travel* and policies DP17 – *Walking, cycling and public transport* and DP19 – *Parking standards and limiting the availability of parking* of the Camden Development Policies. It should be read in conjunction with Development Policies Appendix 2 – Parking standards.

### When does this apply?

9.3 This guidance applies to:

- Applications which involved the creation of one or more additional dwellings;
- Applications which proposed additional floorspace of 500 sq m or more; and
- Applications which are likely to significantly increase the demand for people to cycle to the site.

### How do we implement our cycle parking standards?

9.4 Numerical standards for cycle parking spaces are introduced by policy DP18 of the Camden Development Policies, and set out in detail in Development Policies Appendix 2. These standards are applied at a threshold of 500 sq m in most cases. Throughout the standards, the stated number of spaces relates to the number of bicycles to be accommodated, not to the number of stands.

9.5 Where a development crosses the threshold, requirements apply to the entire floorspace, not only the floorspace above the threshold. For example, at a new leisure development, 1 visitor cycle parking space per 250 sq m is required from a threshold of 500 sq m. This means that no requirement applies to a facility of 400 sq m, but 4 visitor spaces are required for a facility of 1,000 sq m.

9.6 Thresholds and standards are given as a gross floor area (GFA) relating to the development as a whole, and are not intended to be applied

separately to individual units where a development is subdivided into smaller units. Thus, space for cycles may be required for small premises (under 500 sq m) which form part of a larger development.

- 9.7 Table 6.3 of the London Plan sets out additional cycle parking standards and states that additional cycle parking provision will be required for larger (C3) residential units.

### Location, design and layout of off-street cycle parking

- 9.8 Cycle parking should be provided off-street, within the boundary of the site. Cycle parking needs to be accessible (in that everyone that uses a bike can easily store and remove a bike from the cycle parking) and secure (in that both wheels and the frame can easily be locked to the stand). Security is a critical concern in the location, design, enclosure and surveillance of all cycle parking. The table below provides detailed guidance on the location, design and layout of cycle parking for various groups of cyclists.

#### Location of off street cycle parking

##### General

- Cycle parking outside buildings should be positioned near entrances and where frequent surveillance is possible. For short stays, the parking should be sited within 25 metres of building entrances. For stays of over an hour, the parking should be sited within 50 metres of building entrances.
- All cycle parking, including all parts of the parked cycles, should be clear of routes needed for pedestrian movement.
- The route to cycle parking from street level should be step free. cycle parking inside buildings should be at the entrance level of the building or accessible by a ramp or lift from street level that can accommodate a bike.

##### Parking for visitors

Parking for visitors should be clearly visible or clearly signed from the public highway, and should be near building entrances

##### Parking for employees (and other long stay parking)

Parking for employees (and other long stay parking) should be provided either within the building, or otherwise protected from the weather. Consideration should be given to providing lockers and showers for cyclists. For larger development this would be expected and would be a requirement of a Travel Plan (see section 2 of this guidance concerning Travel Plans).

##### Parking for residents

Parking for residents should be within the building. Parking for a resident may take the form of a space within an individual dwelling provided that the space is close to the door of the dwelling, and access to the dwelling is level, or by a ramp or lift that can accommodate a bike.

## Design and layout of cycle parking: Sheffield and “Camden” cycle stands

The Council recommends the use of either “Camden” or Sheffield for the provision of off-street cycle parking, as they meet the Council’s requirements in terms of accessibility and security, provided they are laid out correctly.

- The “Camden” stand is a new form of Sheffield Stand, which is now used for all new cycle parking installed on Camden’s public highway. Developers are encouraged to use it in place of the Sheffield stand, although the Sheffield stand is still acceptable. The Council’s Public Realm and Transport team can advice on purchasing “Camden” stands as they are not as widely available as the Sheffield stand.
- The Sheffield Stand is the most common type of cycle stand used in the public highway. It is recommended for use along with Josta two-tier cycle parking;

Annex 1 provides more detailed guidance on the design and layout of “Camden”, Sheffield and Josta stands.

We are willing to consider other forms of cycle parking, however you must meet our accessibility and security requirements, details of which can be obtained from the Council’s Public Realm and Transport team. Generally, designs that require cycles be lifted into place or provide insufficient opportunity to lock the cycle will not be acceptable.



### The London Cycle Hire Scheme

- 9.9 The London Cycle Hire Scheme is a public bicycle sharing scheme for short journeys in and around central London. Users can pick up a bike from a docking station, use it for short journeys, then drop it off at any docking station, ready for the next person.
- 9.10 Whilst the cycle hire scheme is currently focused around central London, the Mayor of London is investigating its expansion. The Camden Core Strategy states that we will seek to ensure that the scheme is extended to key destinations across the borough, including our town centres (see Core Strategy paragraph 11.13).
- 9.11 Where appropriate, developments close the area covered by the London Cycle Hire Scheme will be expected to contribute towards the scheme,

where justified as a result of increased trips generated. Contributions could include:

- a financial contribution towards cycle hire facilities. The amount sought will be based on the number of additional trips that are generated by the scheme;
- provision of space on-site to accommodate new cycle hire docking stations, in larger developments where there is space and the location is suitable. Transport for London (TfL) is producing a set of guidance for developers regarding specifications and design requirements for docking stations due to be released in 2011.

9.12 Contributions sought will relate both to the individual impact of a scheme and to any cumulative impact of a number of schemes in the same area.

### **Cycle stations**

9.13 Cycle stations provide a secure managed area for cycle parking. The Camden Core Strategy promotes the provision of cycle stations as part of an effort to increase the availability of cycle parking in the borough (see paragraph 11.13 of the Core Strategy), and we intend to create a network of publically accessible cycle stations across the borough.

9.14 We will seek the provision of cycle stations in locations where it will be possible to attract a sufficient number of users. Suitable locations include:

- town centres and the central London area;
- transport interchanges;
- large commercial developments;
- residential areas - linked to new and existing residential development of a suitable scale; and
- larger health and education facilities.

9.15 Where developments generate an increased level of activity they will be expected to provide contributions towards the provision and maintenance of nearby cycle stations, in order to mitigate the effects of the increased number of journeys.

9.16 We will also seek on-site provision of cycle stations as part of larger developments in suitable locations. On-site provision of cycle stations can incorporate a development's cycle parking requirements for visitors (as set out in our parking standards), but should also include extra provision for the wider public. Parking provision for employees and residents of a development, as set out in our parking standards, should be provided separately in order to ensure that they retain the appropriate number of spaces to meet the demand that they generate.

### **Design of cycle stations**

9.17 As a minimum, cycle stations should incorporate indoor, sheltered standard cycle parking (e.g. Camden or Sheffield type cycle stands) with

controlled access to the indoor area, and lighting. Cycle stations can incorporate a variety of other features including automated cycle locks, changing facilities, lockers, toilets and showers. Access to and from the cycle station by bike must be safe and convenient and accounted for within the space.

9.18 The Camden Cycle Stations Programme - Review of Best Practice (March 2009) provides information on best practice in the provision of cycle stations. Features that contribute to a successful cycle station include:

- Being located not more than 100m from the target destination, with shorter stays requiring shorter distances;
- Good surveillance by staff, other users and passers-by.
- Effective maintenance and management
- Clear and unambiguous signing to and within the cycle station.

### **Further information**

9.19 In addition to the guidance provided in Annex 1 below (which includes details on the layout of off-street cycle parking), reference may also need to be made to the Camden Streetscape Design Manual. The manual contains dimensions for on-street cycle parking and the widths required for unobstructed pedestrian routes.

9.20 Other supporting documents include:

- Forthcoming TfL Design and specification of cycle hire scheme
- Forthcoming TfL Guidance on Cycle Stations
- Camden Cycle Stations Programme - Review of Best Practice (March 2009)

9.21 London Cycle Network Design Manual (London Cycle Network Steering Group, March 1998)

### **Annex 1 – Sheffield Stand Cycle Parking**

9.22 This Annex describes in detail how to lay out Sheffield stands. It also can also be applied to the layout of “CaMden” stands.

9.23 The "Sheffield Stand" refers to a common design of cycle parking made from a tubular steel loop, approximately 50mm to 75mm in diameter, that is fixed to the ground (either bolted through a baseplate or set in concrete). Each Sheffield Stand can accommodate two bicycles, one either side, provided there is sufficient clearance next to the stand and sufficient circulation space so all cycle parking spaces can be accessed

9.24 The CaMden Stand is similar to the Sheffield Stand but is in the shape of a rounded “M” rather than a simple loop. This is designed to encourage users to lock both wheels and the frame to the stand, rather than just the top tube / frame.

Figure 3. Sheffield Stand Elevation

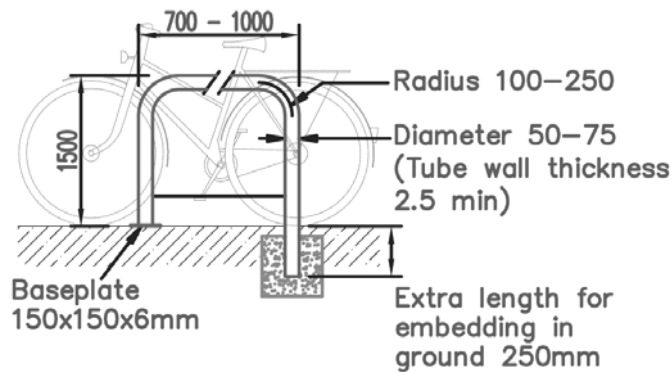
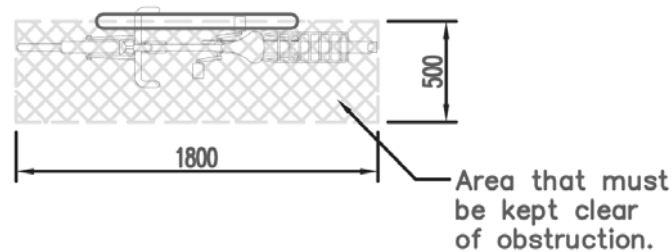
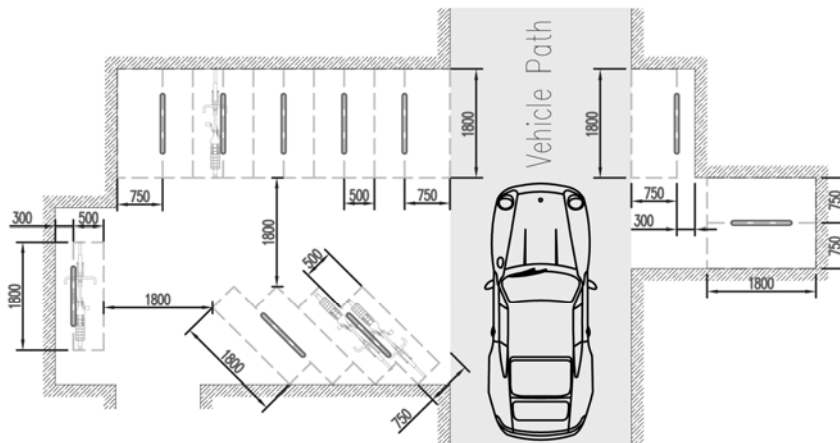

Figure 4. Sheffield Stand Plan



- 9.25 For adjacent stands, an area of at least 1800mm by 500mm next to the stand (measured from the centre line of the tube), must be kept clear for each cycle parking space to allow room for the cycle and working space for locking the bike to the stand. However, if a stand is next to a physical obstruction, such as a wall or a vehicular path, there must be at least 750mm between the stand and the physical obstruction to enable both sides of the stand to be used. If a stand is to be placed close to a wall or other physical obstruction so that only one side of it can be used (i.e. only one cycle can be locked to it), there must be at least 300mm between the stand and the physical obstruction.
- 9.26 Aisles around the cycle store must be at least 1800mm in width. An example cycle store showing various layout options is shown below. Note that the area to be kept clear does not actually have to be marked on the ground, but is shown in outline for clarity.

Figure 5. Cycle stand siting



### Josta Two-tier Cycle Parking

- 9.27 The Josta two-tier cycle parking system (or similar) is generally able to accommodate approximately twice as many cycles per square meter of floor space as Sheffield stands. It also still meets the Council's requirements for accessibility and security, but requires a ceiling height of at least 2500mm.
- 9.28 With a ceiling of at least 2500mm the stands can be placed 650mm apart, i.e.  $X = 650\text{mm}$  in the diagram below.

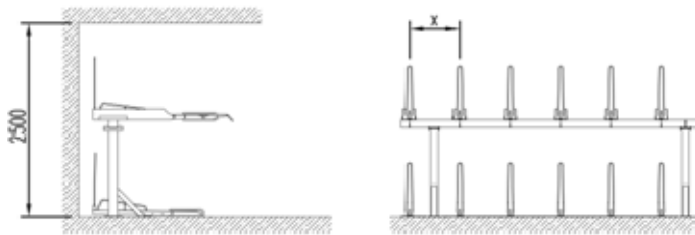

- 9.29 With a ceiling of at least 2700mm the stands can be placed 400mm apart, i.e.  $X = 400\text{mm}$  in the diagram below.

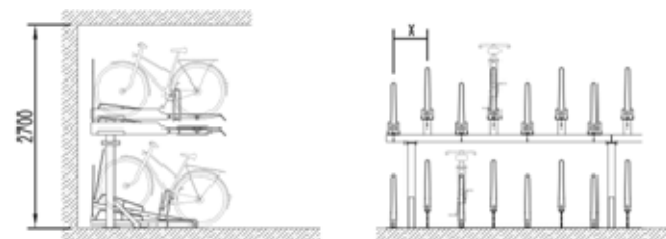

- 9.30 In order to enable the top tier to be used, at least 2500mm of clearance in front of the stand, measured on a line at the same angle at which the top tier stands are extended (see diagrams below), is required between rows of stands, walls or other obstructions.

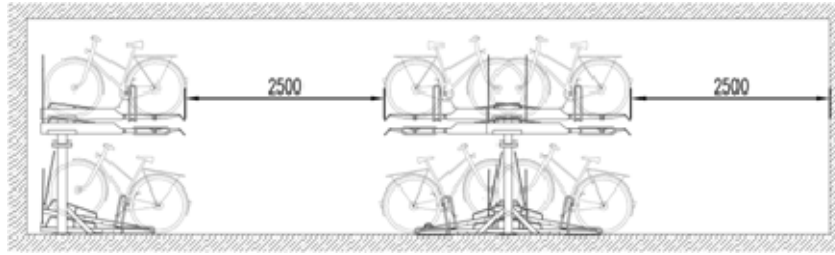

- 9.31 The Josta stands can be arranged at different orientations (angles) provided there is 2500mm of clearance in front of the rack to remove cycles from the top tier (as described above) and aisles around the cycle store at least 1800mm in width. Examples, with minimum distances are shown below. “X” indicates the spacing between stands, which depends on the ceiling height as described on the previous page.



Figure 6. Josta Stand minimum siting dimensions

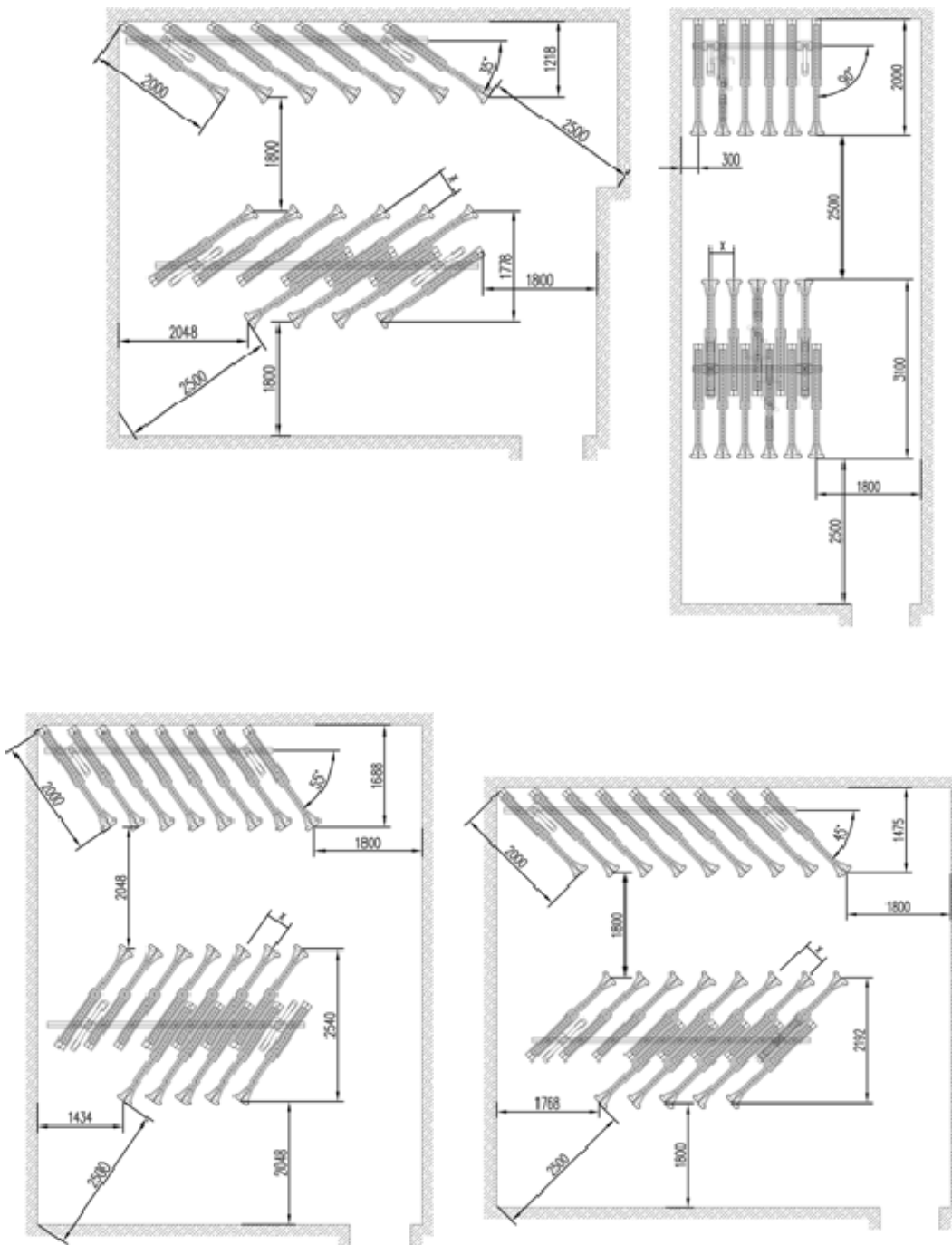

Camden Planning Guidance

# Planning Obligations

London Borough of Camden

CPG 8



## CPG8 Planning obligations

1	Introduction .....	5
2	Background .....	7
3	Amenity .....	15
4	Community facilities .....	21
5	Design .....	29
6	Affordable housing and housing in mixed-use development..	39
7	Sustainability .....	45
8	Employment and business support .....	49
9	Provision of flexible shops and business space .....	55
10	Transport .....	56
11	Provision of public open space .....	59

Strategic Planning and Information  
London Borough of Camden  
Town Hall Extension, Argyle Street  
London WC1H 8EQ  
Tel: 020 7974 2043 / 2519  
Fax: 020 7974 1930  
Email: [ldf@camden.gov.uk](mailto:ldf@camden.gov.uk)  
[www.camden.gov.uk](http://www.camden.gov.uk)

# 1 Introduction

## What does this guidance cover?

- 1.1 The purpose of this guidance is to provide an indication of what may be required when the Council considers that a development proposal needs a planning obligation to be secured through a legal agreement. Planning obligations can be used positively and to address some of the negative impacts of development which would otherwise make a development unacceptable.
- 1.2 Planning obligations are normally secured under Section 106 (S106) of the Town and Country Planning Act 1990. However, the Government currently intends to introduce a Community Infrastructure Levy (CIL) in order to secure infrastructure funding from individual developments. This is intended to operate alongside the Section 106 system and will be explained further below.
- 1.3 The use of planning obligations is an important tool in ensuring the delivery of necessary infrastructure to support the Local Development Framework. They will be used to ensure that the strategic objectives of the LDF Core Strategy and Development Policies are met through requirements attached to individual development proposals.
- 1.4 The use of planning obligations is specifically required through policy CS19 - *Delivering and monitoring the Core Strategy* although a whole range of individual Development Policies may be used to justify an obligation, particularly those relating to affordable housing, sustainability and transport. This guidance is intended to provide general advice on how planning obligations operate. Large scale developments generally have more significant and complex obligations attached to them, but obligations may also be applied to small scale developments to achieve measures such as car free housing or to manage the impacts of construction.

## When will it apply?

- 1.5 This guidance applies to all development where proposals are likely to be subject to planning obligations under Section 106 of the Town and Country Planning Act 1990 (as amended). In dealing with planning applications, local planning authorities consider each proposal on its merits and reach a decision based on whether the application accords with the development plan, unless material considerations indicate otherwise. Where applications do not meet these requirements, they may be refused.
- 1.6 In some instances, however, it may be possible to make acceptable development proposals which might otherwise be unacceptable, through the use of planning conditions (see Department of the Environment Circular 11/95) or, where this is not possible, through planning obligations. Where there is a choice between imposing conditions or entering into a planning obligation a condition will be used.

### 3 Amenity

- 3.1 Development can be positive, but it can also have a significant environmental impact on the amenity of those who live near the development site. It can sometimes cause general nuisance and disturbance, vibration, noise pollution and dust pollution. Development can also have an impact on the surrounding landscape and biodiversity.
- 3.2 The negative impacts of development on amenity can be and short term and connected to the construction phase of the development, or they can be long term and connected to the day to day operation of the development. The negative impact of a development on the amenity of the surrounding area can normally be offset by good design, planning conditions and controls covered by other legislation.
- 3.3 Where these measures are not adequate to deal with the potential negative environmental impacts of a proposed development which is deemed generally acceptable, a S106 Agreement can be drawn up between the Council and the developer, requiring the developer to undertake certain actions to offset those impacts.
- 3.4 The Council will seek to manage the impact of development when considering a development proposal in line with Development Plan policies DP26 and DP28. However, certain aspects of demolition and construction have specific planning implications and may need to be addressed through planning conditions or planning obligations entered into through a Section 106 Agreement.



#### **Construction**

- 3.5 Where demolition and construction is likely to affect local amenity, it is better to consider the environmental impacts at the planning stage and seek ways to minimise them. Many concerns can be addressed through adoption of a co-operative stance between all parties involved and developers should refer to and utilise the Considerate Constructors Scheme.

- 3.6 Many of the environmental impacts of construction works are covered by specific legislation to control pollution, maintain clean air and minimise disturbance. Because of this and other controls small construction projects cause relatively minor amounts of local disturbance and in most cases will not require a section 106 agreement to deal with construction management. However, in the case of large construction and demolition works, planning obligations may be used to minimise the environmental impacts and address the consequences of construction (e.g. to manage construction traffic and/or reinstatement surfaces to a condition that existed prior to construction).
- 3.7 In most cases planning obligations will involve a demolition and/or construction management plan. Please refer to Camden Planning Guidance 6 Amenity, Section 8 for further detail on Construction Management Plans. In these plans the developer undertakes to carry out the demolition or construction works in strict accordance with a plan approved by the Council. The plan may include provisions for phasing, sequential development, management of waste, controlling noise and access during construction. When drawing up the construction or demolition management plan the developer will be required to consult with officers of the Council, the police and local residents and businesses. Local businesses could also be used to supply materials and services in relation to development and construction in order to minimise travel distances and transport costs.
- 3.8 The Council may require the developer to set up a Construction Community Working Group in order to discuss, advise and, where appropriate, make recommendations to the developer in relation to construction management. The Working Group should be made up of an appropriate number of representatives from local residents and/or business associations, a nominee of the Council and/or the Council's Culture and Environment Department, and a project manager and/or Liaison Officer who would act as a point of contact between the local community and the developer.
- 3.9 The Construction Community Working Group can have an input into a Construction or Demolition Plan or Method Statement for Construction, which the developer should submit for the approval of the Council before implementation. The plan or statement should cover the following:
- the programme for construction works;
  - site conditions;
  - erection of hoardings and scaffolding;
  - time of operations;
  - noisy activities;
  - time of deliveries;
  - dealing with construction traffic, vehicles and other likely traffic and parking issues;
  - temporary road and footway closures and surfacing reinstatement/repair proposals; and

- consideration of complaints from the business and residential community.

3.10 Construction should proceed at all times in accordance with this plan or Method Statement.

### **Construction waste**

3.11 The Council will seek to minimise the amount of waste generated by a development and to maximise the amount of waste that is reused or recycled. Developers should try to ensure that construction waste is minimised. Recycling of demolition waste can help reduce the amount of aggregates that have to be transported through London and contribute to the saving of resources.

3.12 Construction waste needs to be disposed of safely and the vicinity of the construction site should be kept in a clean and safe condition. The Council may require the developer to submit for approval a Construction Waste Management Plan separately, or as part an overall Construction and Demolition Plan, which the Developer will be obliged to follow during the period of construction.

### **Noise**

3.13 Noise pollution has a major effect on amenity and on quality of life in general. The Council will not grant permission for noise sensitive development in locations where there is noise pollution, unless appropriate attenuation measures are taken. Policy DP28 *Noise and vibration* sets out the acceptable thresholds for noise in relation to sensitive uses. If suitable separation cannot be achieved the Council will consider whether it is practical to control or reduce noise levels through the use of conditions, planning obligations or other environmental legislation.

3.14 Whilst design measures and planning conditions will often be sufficient to address noise impacts within the development site, planning obligations may require financial contributions to fund:

- noise mapping;
- noise monitoring to identify the number of people adversely affected by noise from road traffic and railways, and to validate noise levels calculated by noise mapping; and/or
- a post development survey to confirm that requisite measures have been implemented successfully.

3.15 In addition the Council may require a noise management plan through a legal agreement, which may require a developer to:

- put in place a scheme for the sound insulation of affected dwellings in order to safeguard amenity;



- reduce noise at source, e.g. by vehicle fleet selection to minimise noise generated by individual vehicles such as delivery lorries, cars and railway vehicles;
- implement off-site noise mitigation measures against traffic noise and vibration such as noise barriers and sound insulation of residential properties and other noise sensitive receivers;
- provide and maintain off-site tree and landscape buffers;
- put into operation a traffic management scheme to reduce road traffic noise; and/or
- work with the local highways authority to implement requisite highways works and a maintenance programme incorporating provision of quieter road surfaces, such as porous asphalt.

### **Contaminated land**

- 3.16 Contamination of the ground and underground water can affect human health, cause harm to the natural environment and damage buildings and underground services. The Council will require measures to remove unacceptable risk from contaminated land and thus make the site suitable for its new use by way of planning conditions.
- 3.17 Where a development includes any potentially contaminative uses the Council will expect proposals to be submitted to prevent future contamination of land or groundwater and may impose planning conditions to that effect. Land contamination issues must be fully addressed in any environmental assessment or statement to accompany a planning application.
- 3.18 For those developments in or adjacent to areas where objectives for land contamination are unlikely to be met by condition (i.e. where there is still a residual impact), the Council will require a S106 planning obligation. The planning obligation will be directed towards measures designed to deal with the contamination, including during construction works, and to make the site suitable for its intended use.
- 3.19 The Council may require a developer to provide a financial contribution for:
- site investigation and remediation works which would include any measures to prevent hazards arising from future use of the site and the disposal or containment of any contaminants;
  - for monitoring following the completion of the development, e.g. measuring gas or water contamination in boreholes or installing permanent monitoring equipment; and/or
  - a post-development survey to confirm that requisite measures have been implemented successfully.
- 3.20 A management plan may also be necessary requiring the maintenance of remedial works such as landscaping or water treatment facilities, or imposing restrictions on the land to minimise and control future potentially hazardous or contaminating development or use of the site.

## **Microclimate**

- 3.21 Large developments have the potential to change the microclimatic conditions in the surrounding area, for example by overshadowing a public space for large parts of the day, or by causing windy conditions around the development. The Council will expect that in the case of a development that has the potential to have an adverse effect on the environmental conditions in a nearby street or public space relevant attenuation measures should be integrated into the proposals.
- 3.22 On-site attenuation measures can also be specified in the planning conditions attached to a planning permission. The Council may require a developer to undertake an assessment (e.g. a wind assessment) of the development as part of the planning application submission. The developer may be required to integrate any findings or recommendations into the finished development. The Council may also require the developer to manage and maintain a development in accordance with an environmental plan, which may need to be approved as part of an application.
- 3.23 In certain cases the adverse effects of a development on the environmental conditions of the public spaces around and within the development may be attenuated by off site measures such as planting trees as a windbreak. Other off-site shading or shielding devices may be required to control or improve the environmental conditions in public and semi public spaces around the proposed development. The Council may require the developer to pay a financial contribution to secure these works.

## 4 Community facilities

- 4.1 Community facilities include childcare facilities, educational and training facilities, healthcare facilities, policing facilities, youth facilities, libraries, community halls, meeting spaces, places of worship, public conveniences and other uses in Use Class D1 that provide a service to the local community. Leisure facilities include cinemas, music venues, theatres, leisure centres, indoor and outdoor sports facilities and other similar uses.
- 4.2 Core Strategy policy CS10 – Supporting community facilities and services, sets out the Council's overarching approach to protecting and providing the community facilities that meet the needs of Camden's growing population. Development Policy DP15 – Community and leisure uses helps to deliver the Core Strategy by providing information about the detailed approach that will be taken to protect existing community and leisure facilities and the expectation that schemes which create additional demand for community facilities to make an appropriate contribution towards community facilities on-site or close to the development.



### **Educational contributions from residential developments**

- 4.3 Camden is a relatively small built up borough, with few opportunities for large scale housing developments. Whilst the number of children likely to be housed in individual schemes for new housing is often relatively small, the cumulative impact of these developments upon the Borough's existing education places is significant, and each new dwelling created in the Borough places increased pressure upon education places and costs.
- 4.4 It is generally accepted that schools should not operate at 100% capacity as it is important to retain some level of surplus capacity to enable parental preference to be exercised. Surplus places are also required to cover fluctuations in the numbers of children requiring places due to, for example, the numbers and location of homeless families being temporarily housed, cross boundary movements, new statutory

requirements to include nursery provision which will affect some primary capacity and redevelopment of 'windfall sites'.

- 4.5 All residential development (Class "C3" of the Town and Country Planning Use Classes) including new build, change of use and conversion where the scheme results in a net increase of five or more dwelling units will normally be expected to provide a contribution towards education provision (except for those categories of development set out below).
- 4.6 The contribution sought will always be proportional to the number and size of dwellings proposed. Contributions will not be sought for single-bedroom or studio dwellings, as these are unlikely to provide accommodation for children. Where a scheme includes a mix of single-bedroom and larger units a contribution will only be sought for the larger units.
- 4.7 Contributions will also not be required from certain other types of residential accommodation:
- Student housing schemes (provided there is no child yield);
  - Specialist elderly housing and Housing in Multiple Occupation (e.g. for young, single people) which will not accommodate children; and
  - Affordable housing for rent or intermediate housing provided by a registered social landlord secured via planning obligations where the Council has 100% Council nomination rights where such accommodation generally houses children already resident and educated in the borough.
- 4.8 The contributions sought will not vary by the location of the development within the Borough as it is difficult to predict the age of children who will actually occupy new housing; because they may move through the Borough's education sectors, and because educational need arises and is planned for at Borough level. Figure 1 on page 23 shows the level of contribution sought for different sized units.
- 4.9 The contribution required from the development as a whole is calculated by multiplying the number of units of each size (excluding one bedroom units or units within the categories set out above), by the potential child yield and then the contribution required by each unit.
- 4.10 Education contributions will be used to improve capacity and expand education provision to accommodate additional children. Examples include providing additional education places, adapting and extending educational buildings and facilities (including nursery and reception classes), providing new schools or educational buildings, or purchasing new equipment required to meet additional demands. Funds may also be used for extra curricular facilities where local pressures arise e.g. related sports and after school clubs and play centres.
- 4.11 Contributions may also be built up over time and pooled in order to optimise their benefits and, until mainstream funding, grants and other revenue sources "catch up" with increased pupil numbers, may be

sought to pump prime initial revenue and maintenance costs. The Council will continue to monitor the situation in relation to education places and Borough capacity, and will update this guidance should the situation alter significantly in relation to supply of education spaces and facilities.

**Figure 1. Calculation of education contributions**

Unit type	Child yield per unit [1] [2]	Education sector [3]	Child yield by education sector	Child yield by sector	DCSF costs per school place [4]	Contribution by education sector	Total contribution per unit [2]
<b>2 bed</b>	0.14	<b>Primary</b>	0.50	0.07	£ 14,830	£ 1,038	
		<b>Secondary</b>	0.38	0.0532	£ 22,347	£ 1,189	
		<b>6th Form</b>	0.12	0.0168	£ 24,236	£ 407	
						£ 2,634	
<b>3 bed</b>	0.40	<b>Primary</b>	0.50	0.2	£ 14,830	£ 2,966	
		<b>Secondary</b>	0.38	0.152	£ 22,347	£ 3,397	
		<b>6th Form</b>	0.12	0.048	£ 24,236	£ 1,163	
						£ 7,526	
<b>4+ bed</b>	1.36	<b>Primary</b>	0.50	0.68	£ 14,830	£ 10,084	
		<b>Secondary</b>	0.38	0.5168	£ 22,347	£ 11,549	
		<b>6th Form</b>	0.12	0.1632	£ 24,236	£ 3,955	
						£ 25,589	

1. Based on information collected through the Camden Survey of New Housing 2002-2008.

2. Reduced by 16.6% to take account of children whose schooling is not met by Camden and the fact that the survey covers 15 year bands whereas schooling only covers 14 year bands.

3. Information taken from Camden School Organisation plans indicates that the balance of children and young people in Camden schools is split between the education sectors in these proportions.

4. Based on the Department for Education and Skills (DfES) established cost of education places in schools taken from 2008/2009. The new department of education has yet to update these figures and new cost figures will be incorporated into this formula as appropriate.

**Example A**

Conversion and extension of a large single family dwelling house to create:

- 2 x 1 bedroom units
- 2 x 2 bedroom units
- 2 x 3 bedroom units

This scheme results in a net increase of five units (and therefore requires a contribution as the threshold is net five or more units). No Child Yield will be presumed for one of the 3-bedroom units as the previous house may have previously been occupied by children. No contributions will be sought from the one-bedroom flats

2 x 2 bedroom flats	2 x £ 2,213	= £ 4,426
1 x 3 bedroom flat	1 x £ 6,322	= £ 6,322
Total		= £ 10,748

**Example B**

New build scheme providing 30 units comprising:

- 8 x 1 bedroom units (4 affordable)
- 16 x 2 bedroom units (8 affordable)
- 4 x 3 bedroom units (2 affordable)
- 2 x 4 bedroom units (1 affordable)

No Child Yield would be presumed for the 8 one-bedroom units. No contribution will normally be sought from affordable housing units (as long as they are secured and protected through a planning obligation and have 100% local authority nomination rights).

8 x 2 bedroom units	8 x £ 2,213	= £ 17,704
2 x 3 bedroom units	2 x £ 6,322	= £ 12,644
1 x 4 bedroom units	1 x £ 21,494	= £ 21,494
Total		= £ 51,842



### **Other Community facilities**

- 4.12 There are a number of community centres and recreation facilities including meeting halls and spaces, libraries and indoor sports halls across Camden, and such centres provide an important component of daily life for a significant section of the population. These can help to enhance quality of life, improve personal health and well being, deliver a sense of community and help to reduce crime.
- 4.13 New residential or commercial development which generates or attracts significant numbers of people to an area may require new provision or lead to an increased demand on existing community facilities near to a site. The provision of these facilities is important in supporting new growth as recognised in planning policies.
- 4.14 Depending on the scale of development, an appropriate level of provision or contribution towards existing or new facilities may be sought and will be determined by considering the likely increase in demand for community facilities resulting from a development and the effect that this will have on existing provision.
- 4.15 Obligations and contributions will not generally be sought for developments of less than 10 residential units or 1,000sq m of floor space. The requirements for community facilities generated by developments will vary and contributions will be sought on the basis set out in the table on page 26.
- 4.16 In exceptional cases where a community facility is to be lost as a result of a development, or a development generates the need for increased facilities the Council will normally expect it to be provided on the development site. Where this is not possible the Council will seek a financial contribution based on the cost of provision of a replacement facility. In cases where a community facility is provided or a contribution is made, the Council will prescribe a specification for the building to facilitate the occupation by community groups, which may include subsidised rents.

**Figure 2. Contributions towards community facilities**

<b>Development</b>	<b>Contribution</b>	<b>Use of funds</b>
General needs housing - developments including market and affordable housing which will result in an increase of 10 or more residential units where onsite community facilities are not provided	£980 per bedroom[1]	Funds are used by Camden Regeneration and Partnerships Team to contribute to improvement to community buildings and facilities within the vicinity of the development.  Funds may be combined with other funds (including lottery and charitable funds) to increase the value of the community benefit obtained.
Student housing and hostels which will result in an increase of 10 or more student bedspaces. The Council will make as assessment looking at the number of units and whether onsite facilities are provided	<b>Onsite</b> A minimum of 1 sq m per bedroom of indoor community space to be provided as common rooms, quiet study area, indoor sports facility[2]  <b>Offsite</b> Where facilities are not provided £980 per bedroom[3] will be required (or a pro rata contribution where on site insufficient).	Funds are used to improve facilities in the vicinity of the development which would be relevant to students living in the scheme, including indoor sports, libraries and community centres where they provide services relevant to young adults
Major mixed use or commercial developments (more than 1,000 sq m) where on site community facilities are not provided	Contributions will be negotiated on a case by case basis relating to the needs generated by the development.	Funds will be used to improve facilities in the vicinity of the development site.

1. Requirement per bedspace = 0.2 sq m x £4,900 per sq m = £980

One bedspace generates the need for 0.2 sq m multi-purpose community space (derived from the Camden Infrastructure Study, based on average space requirement per 1000 people used by 8 local planning authorities in the south east. Similar figure (0.16 sq m per person) can be derived from assessment that 1000 people require 1/3 of a community centre and assuming average 500 sq m GIA)

Build cost per square metre of community facilities is £4,900 (derived from actual build cost including fees and VAT of extensions at five Camden community buildings 2008 – 2010)

2. Most student housing schemes in Camden include some onsite amenity space. No space standards exist for community use provision in student accommodation. 1sq m is a minimum standard for onsite provision based on an analysis of existing student accommodation schemes in Camden.

3. As per build costs for general needs housing



## **Contributions to healthcare**

- 4.17 New development can lead to an increase in demand for new health care provision and put pressure on existing facilities and capacity to meet the health care needs of local residents, workers and visitors to the borough. It is appropriate for those carrying out major new development in Camden to make a contribution towards the provision of health care, particularly local primary health care, if development generates or increases pressures on existing facilities.
- 4.18 This contribution could be financial and is likely to be pooled with similar contributions. For schemes of more strategic importance or involving the replacement of health facilities, it may involve the direct (re)provision of health facilities within or near a proposed development site.
- 4.19 To assess and establish an appropriate level and type of obligation including financial contributions to mitigate any health care impacts, the Council will consult with a range of statutory healthcare providers in the area to identify the healthcare needs likely to be generated by a development.
- 4.20 It will also have regard to the model commissioned by the NHS Healthy Urban Development Unit (HUDU) and produced by Matrix Research and Consultancy ([www.healthyurbandevelopment.nhs.uk](http://www.healthyurbandevelopment.nhs.uk)). The HUDU model is designed to forecast at a high level the health demand that might result from a new residential development and subsequent cost of provision. Obligations and contributions will not generally be sought for developments of less than 50 residential units but local circumstances will need to be assessed, e.g. loss of health facilities.
- 4.21 In schemes of more strategic importance where significant numbers of visitors or workers are going to be generated, in addition to a new residential population, there will be a need for developers to carry out an assessment of the health implications of the development and its impact on local health services.

## 6 Affordable housing and housing in mixed-use development

- 6.1 The Council will use planning obligations to secure the provision of:
- an appropriate proportion of housing in mixed-use developments; and
  - an appropriate proportion of affordable housing in residential and mixed-use developments.
- 6.2 Contributions to housing and affordable housing may be required under Development Policy DP1 – *Mixed-use development* and Development Policy DP3 – *Contributions to the supply of affordable housing*. Policies DP1 and DP3 indicate that the contributions should normally be made on the development site that generates the policy requirement, but the policies provide for off-site contributions in a limited set of circumstances, and these contributions may exceptionally take the form of a payment in lieu.
- 6.3 CPG2 Housing sets out all the Council's usual arrangements for the provision of housing and affordable housing through policies DP1 and DP3, and housing in mixed-use, particularly section 1 Affordable housing and housing in mixed-use development. CPG2 gives guidance on providing housing and affordable housing on-site and off-site, including the use of planning obligations. Paragraphs 2.68 to 2.88 set out the limited circumstances where on off-site contribution may be accepted and the exceptional circumstances where this may take the form of a payment in lieu.
- 6.4 This section of the guidance provides guidance on how payments in lieu of housing/ affordable housing are calculated, but does not provide guidance on any other aspects of policy DP1 and policy DP3. To find out whether a payment in lieu might be acceptable, please also refer to paragraphs 2.68 to 2.88 of CPG2 Housing.



- 6.5 In summary:
- payments-in-lieu will only be accepted under exceptional circumstances where provision cannot practically be made on site

and the applicant demonstrates that no alternative site is available in the area;

- payments-in-lieu of housing and payments-in-lieu of affordable housing will be pooled into an affordable housing fund and used to assist provision of affordable housing
- where a payment-in-lieu at the level anticipated by this guidance would not be viable, arrangements for financial viability appraisal apply, as set out in paragraphs 2.59 to 2.67 of CPG 2 Housing; and
- where development proposals involve a shortfall of the housing or affordable housing required under Policies DP1 or DP3, the Council may negotiate a payment in lieu of the unmet requirement.

### **How the payment levels have been set**

- 6.6 The Council has commissioned research on standard payment-in-lieu figures for housing and affordable housing based on the Camden Affordable Housing Viability Study 2009. The first part of this research (published as the Payments in Lieu Working Paper 2010 – see the evidence base and monitoring section of our Local Development Framework pages at [www.camden.gov.uk/ldf](http://www.camden.gov.uk/ldf)) compared the residual value of a range of market housing development types with and without the affordable housing element sought by Development Policy DP3. These comparisons show the additional value created by omitting affordable housing from the development. This has been converted to a payment per square metre of on-site affordable housing sought.
- 6.7 The second part of the research (published as the Mixed Use PIL Working Paper 2011 – see the evidence base and monitoring section of our Local Development Framework pages at [www.camden.gov.uk/ldf](http://www.camden.gov.uk/ldf)) compared the residual value of a range of Central London office developments with and without the housing element sought by mixed-use Development Policy DP1. These comparisons show the additional value created by omitting housing from the development. This has been converted to two figures for payment per square metre of on-site housing sought, one for small floorspace additions and one for larger floorspace additions (for these larger schemes the housing sought would include affordable housing).

### **The payment levels**

- 6.8 The three discrete payment levels are set out in the table below. One level applies to residential schemes where a contribution to affordable housing is sought under Development Policy DP3. Two payment levels apply to non-residential schemes where a contribution to housing is sought under mixed use Policy DP1. The higher level applies to larger non-residential schemes which would also trigger an affordable housing requirement under Policy DP3. The higher figure takes account of the impact of affordable housing on viability, so it is not necessary to combine the different payment levels.

- 6.9 All figures are expressed as £ per square metre (gross external area). The figures are applied to the **on-site** target for housing/ affordable housing. They should not be applied to the total or additional floorspace of the proposed development, or to the off-site target for affordable housing.

**Figure 3. Housing/ affordable housing payment levels**

<b>Development type/ policy requirement</b>	<b>Level of payment in lieu</b>
Market residential scheme/ affordable housing policy DP3	£2,650 per sq m x on-site target for affordable housing
Non-residential with less than 2,000 sq m additional floorspace (gross external area)/ mixed-use policy DP1	£700 per sq m x on-site target for housing
Non-residential with 2,000 sq m additional floorspace or more (gross external area)/ policies DP1 and DP3	£1,350 per sq m x on-site target for housing

- 6.10 The payment levels in Figure 3 for non-residential schemes have been derived on the basis of developments that omit *all* types of housing requirement (under DP1 and DP3), and are based on costs and values for office developments. These figures may not be appropriate for a large non-residential scheme that only omits affordable housing, or where the primary use is a non-office use such as retail or a hotel. Where the type of development proposed is substantially different from the developments used to set the payment levels, or the payment levels indicated in Figure 3 would not be viable, the Council will:
- apply the arrangements for financial viability appraisal set out in paragraphs 2.59 to 2.67 of CPG2 Housing; and
  - negotiate a payment on the basis of the financial viability of the particular development.
- 6.11 For a primarily residential scheme with a non-residential element of less than 1,000 sq m gross, if the Council agrees that a payment in lieu of affordable housing is appropriate, the level of payment will be guided by policy DP3 and the figure of £2,650 per sq m of on-site target for affordable housing.

**GROSS EXTERNAL AREA**

Calculations in this guidance are based on Gross External Area (GEA). This is generally the total area of every floor in the building including common areas and external walls. Payment-in-lieu figures have been calculated on that basis.

Floorspace measurements are sometimes provided which exclude common areas and exterior walls of the building (this often applies to flats), or just exclude the exterior walls (this often applies to houses). Where a figure for Gross External Area including common areas is not available, the Council will consider using a conversion factor to assess the housing/ affordable housing requirement and to calculate the payment in lieu.

- To convert to GEA where common areas and exterior walls have been excluded - multiply by 1.25.
- To convert to GEA where only exterior walls have been excluded – multiply by 1.053.

A fuller explanation of the terms Gross External Area and Gross Internal Area is given in paragraph 2.25 of CPG2 Housing.

**How to calculate affordable housing payments under policy DP3**

- 6.12 Where the payment is in lieu of affordable housing under Development Policy DP3, calculations of the payment will proceed in accordance with CPG2 Figure 2 and paragraphs 2.31-2.32 and 2.35, as follows:
- the capacity of the site will be assessed and be converted into a percentage target for on-site affordable housing;
  - the percentage target for on-site affordable housing will in turn be assessed and converted into a floorspace figure (GEA);
  - the target for off-site affordable housing floorspace will be multiplied by the payment per square metre figure of £2,650.
- 6.13 Please refer to CPG2 for full details of the factors which influence capacity and on-site affordable housing target. In summary:
- assessment of capacity is based on the number of additional homes proposed and the gross floorspace addition including common areas;
  - capacity is assessed as the number of additional homes proposed or 1 home per additional 100 sq m (gross), whichever is the greater;
  - capacity is rounded to the nearest whole number;
  - the on-site affordable housing target is assessed as 10% where capacity is 10 additional homes plus 1% for every further increase of capacity by 1 home, up to a target of 50% where capacity is 50 additional homes.

**Figure 4. Example calculations: payments in lieu of affordable housing under policy DP3**

<b>Example 1</b> 21 additional homes with a built floorspace of 1,750 sq m gross	Site capacity = 21 homes
Percentage target for on-site affordable housing	= 21%
Floorspace target for on-site affordable housing	= 1,750 x 21% = 367.5 sq m
Payment-in-lieu of affordable housing	= 367.5 sq m x £2,650 = £973,875
<b>Example 2</b> 22 additional homes with a built floorspace of 2,360 sq m gross	Site capacity = 24 homes
Percentage target for on-site affordable housing	= 24%
Floorspace target for on-site affordable housing	= 2,360 x 24% = 566.4 sq m
Payment-in-lieu of affordable housing	= 566.4 sq m x £2,650 = £1,500,960

#### **How to calculate housing payments under policy DP1**

6.14 Where the payment is in lieu of housing under Development Policy DP1, calculations of the payment will proceed as follows:

- the additional floorspace proposed will be multiplied by the 50% target for on-site housing to produce a floorspace target (GEA);
- where the additional floorspace proposed is less than 2,000 sq m (GEA)
  - the on-site housing floorspace target is less than 1,000 sq m (GEA)
  - consequently no contribution to affordable housing would be sought under policy DP3
  - the target for on-site housing floorspace will be multiplied by the payment per square metre figure of £700;
- where the additional floorspace proposed is 2,000 sq m (GEA) or more
  - the on-site housing floorspace target is 1,000 sq m (GEA) or more
  - consequently an on-site contribution to affordable housing would be also be expected under policy DP3
  - the target for all on-site housing floorspace will be multiplied by the higher payment per square metre figure of £1,350.

**Figure 5. Example calculations:  
payments in lieu of housing under policy DP1**

<b>Example 1</b>	
Total floorspace addition	= 800 sq m
Target for on-site housing	= 800 x 50% = 400 sq m
Affordable housing sought?	No
Payment level	£700 psm
Payment-in-lieu of market housing	= 400 sq m x £700 = £280,000
<b>Example 2</b>	
Total floorspace addition (NB an on-site housing contribution would be required unless there is clear evidence that off-site provision is more appropriate)	= 2,400 sq m
Target for on-site housing	= 2,400 x 50% = 1,200 sq m
Affordable housing sought?	Yes
Payment level	£1,350 psm
Payment-in-lieu of all housing	= 1,200 sq m x £1,350 = £1,620,000

## 7 Sustainability

- 7.1 Promoting a sustainable Camden is an integral element of our Local Development Framework strategy. Core Strategy policy CS13 - *Tackling climate change through promoting higher environmental standards* sets out a key part of our overall approach to tackling climate change, which includes promoting higher environmental standards in design and construction.
- 7.2 Core Strategy policy CS13 states that the Council will have regard to the costs and feasibility of measures to tackle climate change within developments (paragraph 13.4). This approach also applies to policy DP22. We will also take into account the cumulative costs of not responding to the need to mitigate and adapt to climate change as well as the long term cost savings, such as on energy and water bills, to future occupiers. Measures to tackle climate change are integral in the development process and are a priority of the Council, therefore, they should not be seen as 'add-ons'. They are an essential element of sustainable development. For further information on ways to achieve carbon reductions and more sustainable developments please refer to Camden Planning Guidance note 3 – Sustainability.



### **Biodiversity/habitats;**

- 7.3 Planning obligations may be used to require developers to carry out works to secure or reinstate existing habitat features, enhance existing features, create new features or to undertake habitat creation schemes. In those very exceptional cases where a developer cannot protect an ecological habitat adjacent to or within the boundaries of the site and in other respects the development is acceptable they will be required to provide an alternative compensatory measure of equal or greater value. These measures could be land off-site on which the Council or other responsible agency can carry out works and recover the reasonable costs from the developer, or assistance in enlarging or enhancing existing nature conservation assets and habitats and make provision for maintenance of the site.



- 7.4 A planning obligation may also be appropriate where additional monitoring or survey work is considered necessary to confirm that relevant environmental measures have been implemented successfully. Some developments may result in increased activity and affect the value of areas of nature conservation merit adjacent to or within the site. In certain circumstances legal agreements may be appropriate to restrict types and hours of activities and development rights. They may also be used to control access so as not to damage or harm existing features and to make proper provision for the long-term maintenance of directly affected sites

### **Sustainable Design and Construction**

- 7.5 Policy DP22 – *Promoting sustainable design and construction* contributes towards delivering the strategy in policy CS13 by providing detail of the sustainability standards we will expect development to meet. Meeting the requirements for sustainable design and construction is often achieved in the detailed design or construction phases. Normally, requirements for environmental design will be dealt with using conditions, but in some circumstances, a Section 106 agreement may be required to secure an environmental assessment of the proposed development carried out by an impartial assessment body or a sustainability plan to provide and maintain the highest environmental standards of development.
- 7.6 If they cannot be implemented through the approved design or satisfactorily secured through conditions, the following design features may be specified through a sustainability plan required to be submitted as part of a s106 Agreement:
- energy efficient design measures;
  - renewable energy facilities;
  - waste and recycling storage facilities;
  - water retention and recycling facilities;
  - heating or cooling systems;
  - internal water consumption levels; and
  - materials sourcing proportions.
- 7.7 Other specific management plans may normally be required through a condition of a planning approval. However, some proposals or aspects of a proposal might generate a requirement for a management plan to deal with some of the following issues, depending on the scale, nature and location of the scheme:
- waste management;
  - energy including renewable energy on site and energy efficiency;
  - facilities management;
  - construction and demolition;
  - water efficiency;

- Sustainable Drainage Systems (SUDs)
- community safety;
- contamination;
- hazardous substances; and
- biodiversity.

This list is not exhaustive, and the requirements will be relevant, proportionate and related to the specific nature and potential impacts of the development proposed.

- 7.8 Camden Planning Guidance 3, Sustainability provides further detail on the appropriate standards for different types of development – BREEAM, Ecohomes or the Code for Sustainable Homes. A Section 106 Agreement may be used by the Council to require the developer to carry out and submit a post-construction review to ensure that the development has met the criteria which were approved earlier as part of the estimate and design stage assessments. The Council will not permit occupation of the development until a satisfactory post-construction review has been provided and any issues identified in that review have been satisfactorily addressed

### **Decentralised energy networks**

- 7.9 Developments are expected to connect to a decentralised energy network and use the heat, unless developers can demonstrate it is not technically feasible or financially viable. Developers should use guidance in CPG3 – Sustainability chapter 5, to determine whether connection to a decentralised energy network, a combined heat and power plant or a contribution towards a decentralised energy network will be expected.
- 7.10 Where appropriate s106 agreements will be used to secure:
- the installation of CHP/CCHP and the generation and use of energy;
  - details that ensure the plant and its operation is carbon dioxide efficient with regards to operating hours, compatibility with the need (amount and timing) for heat, and requirements for a heat store;
  - details that ensure the design of the heating system is compatible with any nearby decentralised energy network;
  - the export of heat, cooling and/or electricity;
  - development use heat, cooling and or electricity from a decentralised energy network;
  - sufficient space is provided for future plant, heat exchanges, connection points to either generate, export and take heat, cooling and/or electricity; and
  - a financial contribution towards future decentralised energy networks.

- 7.11 The financial contribution expected will be in line with the following table taken from CPG 3 - Sustainability (chapter 5):

<b>Size of development</b>	<b>Residential (per dwelling) or per 300sq m of non-residential floorspace</b>
Over 20 storeys	£2,800
8-20	£2,500
5-7	£2,800
3-4	£4,100
2-3	£5,300
Single dwelling houses or Single storey commercial developments	£8,600

Source: Community energy: Urban planning for a low carbon future

## 10 Transport

### Car free and car capped housing

- 10.1 In order to encourage use of other types of transport and reduce parking stress the Council will use legal agreements to make development car free or car capped. This will limit the number of new residents from being able to obtain on-street parking permits.
- 10.2 Agreements will require the owner of the property to inform the Council's Planning Obligations officer in writing of the official postal address of the property and to clearly identify the car free units before the development is occupied. The owner will also be required to inform any occupants of the property of any car free restrictions. Please refer to the Guidance note on car free and car capped developments for an explanation why the Council imposes these restrictions.
- 10.3 Once planning permission is granted which includes a car free restriction, a copy of the agreement will be passed to the Council's permit issuing team who will maintain a record of properties excluded from obtaining a parking permit. In cases where part of the property is subject to a car free restriction no parking permits will be issued until the owner or developer has clarified in writing with the Council's Planning Obligations officer the official postal address of the property and identified the unit(s) to which the car free restriction applies.

### Travel plans

- 10.4 The Council may use legal agreements to require travel plans to manage the impacts of the development where these measures are deemed necessary to control the impacts of the development. A contribution may be sought to cover the staff costs for overseeing the implementation of these plans. Please refer to guidance note on Travel Plans and Transport Assessment for further information

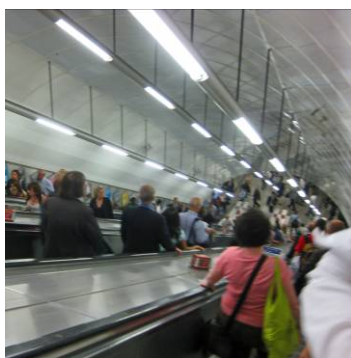

## Public transport contributions

### a) Contributions towards Crossrail

- 10.5 The collection of funds for Crossrail is required under Policy 6.5 of the London Plan 2011 (Funding Crossrail and other strategically important transport infrastructure) which states that:

*In view of the strategic regional importance of Crossrail to London's economic regeneration and development, and in order to bring the project to fruition in a suitably timely and economic manner, contributions will be sought from developments likely to add to, or create, congestion on London's rail network that Crossrail is intended to mitigate. This will be through planning obligations, arrangements for the use of which will be established at strategic level, in accordance with relevant legislation and policy guidance.*

- 10.6 In July 2010 Supplementary Planning Guidance was published by the Mayor explaining how the system will operate. In Camden it is that all office, retail and hotel development schemes in Central London and the Euston and Kings Cross Opportunity area which add more than 500sq m of floorspace will need to pay a charge. The charging rates and land uses are given in the table below and there will be a 20% reduction on charges paid before March 2013.

Use	Rate per sq m
Office	£137
Retail	£88
Hotels	£60

- 10.7 Applicants' are recommended to consult the final Crossrail Supplementary Planning Guidance Note which can be viewed on the Greater London Authority web site. The charge will be collected by Camden on behalf of the Mayor. The negotiation of the contribution towards Cross Rail will be carried out having regard to Policy 8.2 in the 2011 London Plan.

### b) Other public transport contributions

- 10.8 Where public transport provision is not adequate to serve a development (in terms of capacity, frequency, reliability, boarding points, access to boarding points and vehicles), the Council may seek a contribution to public transport provision. This will be assessed through the transport assessment. Please see guidance note on Assessing transport capacity.
- 10.9 The Council will therefore consider mechanisms such as those listed below to reconcile development proposals with the public transport services which will serve them:

- seeking contributions to existing provision so that they can serve the development better (examples could include enhancing pedestrian routes to stops, providing shelters, better seating and real-time information at stops, or increasing service frequencies); and
  - seeking contributions towards pooled funds to be used towards a particular provision or type of provision once accrued funds are adequate (examples could include funds for bus priority measures extending some distance along a route, for an extension to a route, or for a co-ordinated series of measures across an area to make public transport safer at night).
- 10.10 The Council will generally consider seeking contributions towards facilities that assist the use of public transport services which have an existing or proposed boarding point within a convenient walking distance of the development. For bus services, a convenient walking distance is generally up to 400 metres. For rail services, a convenient walking distance is generally up to 800 metres.

### **Pedestrian, cyclist and environmental improvements**

- 10.11 Developments that lead to an increase in trips in the borough have a cumulative impact on Camden's transport network, particularly the public transport network and pedestrian flows. To help mitigate this impact, the Council may seek contributions to improve provision for pedestrian and cyclists as well as making the public realm more accessible and attractive.
- 10.12 Therefore for larger developments (above 1,000 sq m), the Council may seek contributions toward pedestrian, cyclist and environmental improvements in the local area in addition to any works which might be required to integrate the development with the surrounding public highway network. The Council will seek flexibility in the S106 to allow funds to be spent on an agreed range of relevant transport projects. This will allow co-ordination with other projects in the area, which may have a variety of funding sources.

## 11 Provision of public open space

- 11.1 Many developments by the extent and nature of their occupancy will lead to an increase demand for and use of public open spaces. The protection and improvement of these spaces and the provision of new open spaces in Camden is encouraged by policies CS15 and DP 31 of the LDF.
- 11.2 CPG 6 Amenity sets out the detailed guidance on how public open space should be provided in new developments. In summary, the Council's preference is:
1. On site provision of new public open space;
  2. Off site provision of new public open space;
  3. Providing a financial contribution in lieu of direct provision.
- 11.3 Where developments cannot realistically provide sufficient open space to meet the needs of their occupants on or off site the Council will ask a financial contribution. The contribution will be used to improve existing public open spaces or towards the provision of new public open spaces. The Council may seek to coordinate contributions with sites identified Parks Improvement Plan and Biodiversity Action plan provided that these relate to impacts generated by the development.
- 11.4 The contribution will be based on:
- capital cost of providing new public open space;
  - cost of maintenance for the first 5 years; and
  - cost for the open space team to administer the contribution and design schemes.

**Figure 6. The financial contributions**

	<b>Capital cost</b>	<b>Maintenance</b>	<b>Design and admin</b>
<b>Self-contained homes in Use Class C3</b>			
One bedroom home	£ 385	£ 386	£ 46
Two bedroom home	£ 663	£ 561	£ 80
Three bedroom home	£ 1,326	£ 832	£ 159
Four bedroom home	£ 1,537	£ 921	£ 184
<b>Student housing, hotels and hostels</b>			
Single room	£ 297	£ 297	£ 37
Double room	£ 593	£ 594	£ 71
<b>Commercial/ higher education development in the Central London Area</b>			
Per 1,000 sq m	£ 1,265	£ 1,284	£ 152

- 11.5 Please refer to CPG 6 Amenity for the full explanation and worked examples.