



SYNTEGRA CONSULTING
Intelligent & Green Building Solutions



Energy Strategy Report - Planning Application

05th February 2014

**10A Oakhill Avenue,
London, NW3 7RE**

Table of Contents

1. EXECUTIVE SUMMARY	5
2. INTRODUCTION	5
3. THE DEVELOPMENT CONFIGURATION SCHEME	11
4. BASELINE CO ₂ EMISSIONS	13
5. BE LEAN – ENERGY EFFICIENT DESIGN.....	14
6. BE CLEAN – CHP & DECENTRALISED ENERGY NETWORKS.....	16
7. BE GREEN – RENEWABLE ENERGY	18
8. CONCLUSION	22
9. APPENDIX.....	23

10A Oakhill Avenue, London, NW3 7RE

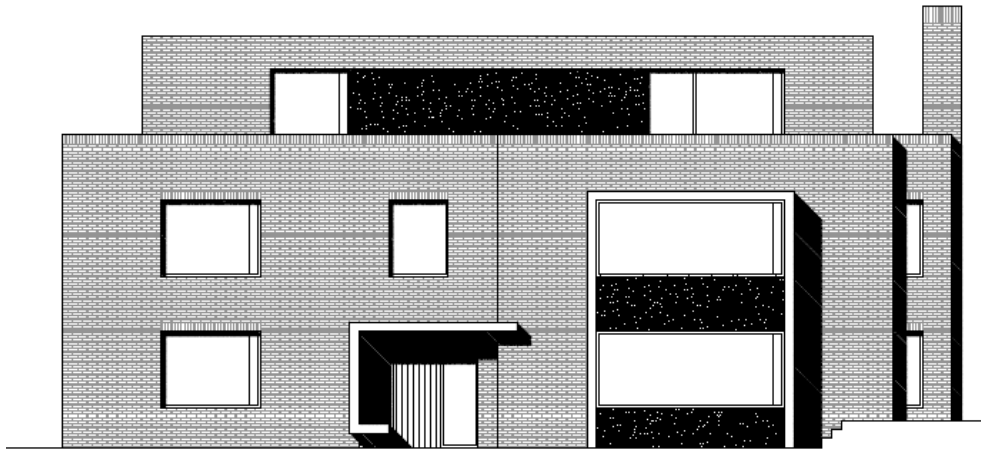

South East Elevation



North West Elevation

Revision:	-			
Date:	05/02/2014			
Prepared by:	RN			
Checked by:	NP			
Authorised by:	AWK			

Limitations

Syntegra Consulting Ltd ("SC") has prepared this Report for the sole use of **Eli Nathenson and Julian Bier** ("Client") in accordance with the Agreement under which our services were performed. No other warranty, expressed or implied, is made as to the professional advice included in this Report or any other services provided by SC. This Report is confidential and may not be disclosed by the Client or relied upon by any other party without the prior and express written agreement of SC.

The conclusions and recommendations contained in this Report are based upon information provided by others and upon the assumption that all relevant information has been provided by those parties from whom it has been requested and that such information is accurate. Information obtained by SC has not been independently verified by SC, unless otherwise stated in the Report.

The methodology adopted and the sources of information used by SC in providing its services are outlined in this Report. The work described in this Report was undertaken in **February 2014** and is based on the conditions encountered and the information available during the stated period of time. The scope of this Report and the services are accordingly factually limited by these circumstances.

This renewable report and SAP pre-assessment modelling were generated based on the provided drawings and building information assumptions. Although every effort has been made to provide accurate content within this report, SC makes no warranty or assumes no legal liability or responsibility for the accuracy or completeness of information contained in this report.

SC also wishes to make aware that this document is guidance only on energy strategy and should not be seen as a building design document. It is the responsibility of the APPOINTED BUILDING SERVICES / Design Team to develop, select and implement appropriate energy efficiency measures to ensure compliance.

Where assessments of works or costs identified in this Report are made, such assessments are based upon the information available at the time and where appropriate are subject to further investigations or information which may become available.

SC disclaim any undertaking or obligation to advise any person of any change in any matter affecting the Report, which may come or be brought to SC's attention after the date of the Report.

Certain statements made in the Report that are not historical facts may constitute estimates, projections or other forward-looking statements and even though they are based on reasonable assumptions as of the date of the Report, such forward-looking statements by their nature involve risks and uncertainties that could cause actual results to differ materially from the results predicted. SC specifically does not guarantee or warrant any estimate or projections contained in this Report.

Costs may vary outside the ranges quoted. Whilst cost estimates are provided for individual issues in this Report these are based upon information at the time which can be incomplete. Cost estimates for such issues may therefore vary from those provided. Where costs are supplied, these estimates should be considered in aggregate only. No reliance should be made in relation to any division of aggregate costs, including in relation to any issue, site or other subdivision.

No allowance has been made for changes in prices or exchange rates or changes in any other conditions which may result in price fluctuations in the future. Where assessments of works or costs necessary to achieve compliance have been made, these are based upon measures which, in SC's experience, could normally be negotiated with the relevant authorities under present legislation and enforcement practice, assuming a pro-active and reasonable approach by site management.

Forecast cost estimates do not include such costs associated with any negotiations, appeals or other non-technical actions associated with the agreement on measures to meet the requirements of the authorities, nor are potential business loss and interruption costs considered that may be incurred as part of any technical measures.

Copyright

© This Report is the copyright of SC. Any unauthorised reproduction or usage by any person other than the addressee is strictly prohibited.

1. Executive Summary

The design of the proposed development in **10A Oakhill Avenue, London, NW3 7RE**, which is a new residential development comprised of **1No. New Build Residential Unit (House)**, located in an urban residential area in London, has incorporated building fabric enhancement (above current building regs requirements) to increase the energy efficiency of the building. This includes that the development uses less energy, by adopting sustainable design and construction measures and by supplying energy efficiently.

Given the complexity of calculating and assessing CO₂ emissions, the **Camden Council** requires all proposed developments to incorporate sustainable design and construction measures. **All new developments are to be designed to minimise energy demand through good design and high levels of insulation and air tightness (CPG3 - Energy Efficiency: New Buildings)**. Schemes must demonstrate how sustainable development principles have been incorporated into the design and proposed implementation. **According to the Camden Planning Guidance, it is requested for new developments to meet Code for Sustainable Homes 'Level 4'** as a minimum requirement, by achieving the minimum standards for specific categories (% of un-weighted credits) of **50% of the credits achieved under the Energy, Water and Materials sections** in accordance with the Development Policy DP22: Promoting sustainable design and construction & the CPG3: Sustainability Assessment Tools (9.8). **Also, according to the CS13 policy, developments need to achieve a reduction in CO₂ emissions of 20% from on site renewable energy generation.**

The recommendation for the proposed development is that an **Efficient ASHP with Underfloor heating and a total of 7.85kWp PV, which equals to 24PV panels in total (based on 327W PV output) and approximately 39.15 m² required roof area** should be progressed. This is based on the following reasons:

1. The strategy would provide **an average of 62.9% CO₂ reduction saving (DER/TER) against current building regulations for the whole development. Therefore, the strategy meets BRUK-L1A requirements for the development and the minimum requirements for ENE01 – Level 4 for CSH assessment.**
2. The strategy would provide an average of **22% reduction of CO₂ emissions the energy demand via onsite renewable technology (PV) for the overall development. Hence, the required target of 20% reduction in CO₂ emissions through renewable onsite has been achieved.**

3. A separate CSH pre-assessment has been undertaken for the residential development. **The CSH pre-assessment demonstrates that a “Code Level 4” rating can be achieved for the dwelling.**
4. After the application of the Energy Hierarchy, the regulated carbon dioxide emissions are presented on the table below:

	Carbon Dioxide emissions (Tonnes CO ₂ per annum)
	Regulated
Baseline: Building Regulations 2010 Part L Compliant Development	34.140
After energy demand reduction	16.217
After CHP/ Communal Heating	16.217
After renewable energy	12.653

The chart below summarises the regulated carbon dioxide savings from each stage of the Energy Hierarchy:

	Regulated Carbon Dioxide savings	
	(Tonnes CO ₂ per annum)	(%)
Savings from energy demand reduction	17.923	52.5%
Savings from CHP/ Communal Heating	0	0%
Savings from Renewable energy	3.564	22%
Total Cumulative Savings	21.487	62.9%
Total Target Savings	8.102	40%
Annual Surplus	13.385	

Meeting the Policy requirements:

- **The overall score is 73.45, thus achieving Code Level 4.**
- Under the **Energy category**, the development achieves **22.6 credits out of 31 credits** available (more than 50% of the planning policy required credits).
- Under the **Water category**, the development achieves **3 credits out of 6 credits** available (50% of the planning policy required credits).
- Under the **Materials category**, the development achieves **13 credits out of 24 credits** available (more than 50% of the planning policy required credits).



2. Introduction

Syntegra Consulting Ltd has been appointed as energy consultants to produce an energy strategy for the **'Development consisting of 1No. New Build Residential unit'** for the scheme at **10A Oakhill Avenue, London, NW3 7RE** – to support the scheme design process, demonstrate Building regulations Part L compliance, intent to design to target Code Level 4 standard and intent to target a 20% reduction of CO₂ emissions reduction via onsite renewable energy technology for the development in accordance with planning policy requirements.

This report will outline the following:

- 1) This report will assess the proposed development site's estimated energy demand & CO₂ emissions. It will look into the feasibility of Low Zero Carbon technologies, examining the following aspects relative to LZC/renewable technologies:
 - Energy generated by Renewable/Low Zero Carbon Technologies (LZC)
 - Feasibility assessment for each Renewable/Low Zero Carbon Technologies (LZC)
 - Local Planning Requirements
 - Life cycle Costs & payback period for the technology investment
 - Available Grants
- 2) The Code for Sustainable Homes (CSH) pre-assessment strategy (under the current CSH Nov 2010 guide) in terms of the intent in achieving the **overall minimum Code Level 4** strategy for the development. –In accordance with the local planning policy targets.
- 3) The proposed building fabric and Low Zero Carbon (LZC) design strategy and analysis calculations, with respect to the Standard Assessment energy assessment Procedure (SAP). Demonstration of how the design is compliant against the current 2010 Part L1A buildings regulations i.e **A 40% DER/TER CO₂ emission reduction against BRUKL Part L1A 2010** – In accordance with the London Plan 2011 and local planning policy targets.
- 4) The target of **at least 20% reduction of the development's CO₂ Emissions** through the utilisation of renewable technology as per the planning policy requirements.

2.1 Site Description

The proposed development comprises of a six storey residential development. The development is located in the urban area of Hampstead in London. The development is in close proximity to Hampstead Underground Station (approx 0.6 miles). The site is within the London Borough of Camden.

2.2 Policy documents

National Planning Policy Framework (March 2012)

The National Planning Policy Framework is a key part of our reforms to make the planning system less complex and more accessible, to protect the environment and to promote sustainable growth.

London Borough of Camden, DP22 “Promoting sustainable Design & Construction”

DP22 – *Promoting sustainable design and construction* contributes towards delivering the strategy in policy CS13 by providing detail of the sustainability standards we will expect development to meet.



The London Plan Renewable Energy Policy 2011 (Policy 5.2, 5.6 & 5.7)

The Mayor will and boroughs should in their DPDs adopt a presumption that developments will achieve a reduction in carbon dioxide emissions of 20% from onsite renewable energy generation according to 5.42 section of Policy 5.7 Renewable Energy (which can include sources of decentralised renewable energy). According to Policy 5.2 (clause B) all residential and non-residential buildings should show an improvement of 25% BER/TER based on 2010 Building Regulations, between 2010 and 2013 and 40% BER/TER from 2013 to 2016, unless it can be demonstrated that such provision is not feasible. Furthermore, intent must be shown for connecting to a Decentralised energy Network according to Policy 5.6 and utilizing a Combined Heat & Power.

2.3 The Energy Hierarchy

The Mayor's Energy Strategy adopts a set of principles to guide design development and decisions regarding energy, balanced with the need to optimise environmental and economic benefits. These guiding principles have been reordered since the publication of the Mayor's Energy Strategy in Feb 2004 and the recently adopted replacement London Plan 2011 states that 'The following hierarchy should be used to assess applications:

- *Using less energy, in particular by adopting sustainable design and construction measures;*
- *Supplying energy efficiently, in particular by prioritising decentralised energy generation; and*
- *Using renewable energy.*

The development Energy strategy has adopted the following design ethos:

- **BE LEAN** – By using less energy and taking into account the further energy efficiency measure in comparison to the baseline building.
- **BE CLEAN** – By supplying energy efficiently. The clean building looks at further carbon dioxide emission savings over the lean building by taking into consideration the use of decentralise energy via CHP.
- **BE GREEN** – By integrating renewable energy into the scheme which can further reduce the carbon dioxide emission rate.

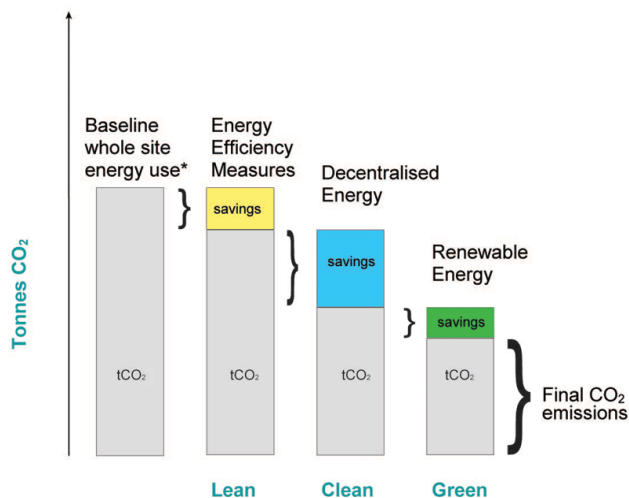

3. The Development configuration scheme:

The proposed development scheme consists of the following characteristics:

3.1 The Unit configuration

The following table presents the type, area and number of units to be assessed within this report:

Proposed unit to be assessed for the development

Type of Unit	Number of units	Number of bedrooms	Individual Dwelling Area m ²
House	1	7	1616.5
Total	1	7	1616.5

Table 1

3.2 Specification of Building Materials

The table presented below demonstrates the material properties of the building fabric that have been proposed:

Envelope Specification

Building Element	Proposed Specification
External Walls U-value	0.15 (basement) 0.2 (exposed)
Floor U-value	0.15
Window units (whole window) U-value	1.4 Double glazing
Rooflight U-value	1.4 Double glazing
Roof U-value	0.12
Air Permeability m³/(h.m²) at 50 Pa	4
Low Energy Lighting	100%

Table 2

3.3 Fuel

The assessment has assumed the following fuel carbon emissions factors - The fuel carbon emissions factors used are in accordance with **SAP 2009 (for Building Regs Part L1A)**.

Carbon Emissions Factor	SAP 2009 kgCO ₂ /kW
Grid Electricity	0.517
Grid displaced Electricity	0.529
Manufactured smokeless fuel	0.402
Coal (traditional British Coal)	0.301
Heating Oil	0.28
LPG	0.25
Natural Gas	0.198
Wood Pellets	0.028
Bio Diesel	0.098
Bio Gas	0.019

Table 3

4. Baseline CO₂ Emissions

The baseline energy use and resulting CO₂ emissions rates of the development have been assessed using the SAP 2009 Government approved software. The SAP 2009 calculations have been produced according to the ADL1A 2010 building regulation requirements.

For the purpose of this report the baseline energy use and CO₂ emissions are calculated based on the minimum requirements specified in the Building Regulations ADL1A 2010 (Table 4).

	Part L1A compliant	Proposed building values
Air Permeability m ³ /(h.m ²) at 50 Pa	10	4
Wall U value W/m ² C ⁰	0.30	0.15/0.20
Roof U value W/m ² C ⁰	0.20	0.12
Floor U value W/m ² C ⁰	0.25	0.15
Window U value W/m ² C ⁰	2.0	1.4

Table 4

The baseline average energy use and CO₂ emissions for the development are presented in the table below:

Building Services	Baseline CO ₂ Emissions (kg CO ₂ /m ² /yr)
Heating	18.99
Auxiliary	0.05
Lighting	0.87
Hot Water	0.57
Total regulated emissions	21.12

Building Services	Baseline CO ₂ Emissions (kg CO ₂ /m ² /yr)	Baseline CO ₂ Emissions (Tonnes CO ₂ / yr)
Total regulated emissions (heating, hot water, lighting, fans & pumps)	21.12	34.140

5. BE LEAN – Energy Efficient Design

This section outlines the design energy efficient measures taken in order to minimise the building's energy demand and therefore reduce energy use and CO₂ emissions further than the Baseline (Building Regulations 2010 Part L compliance).

The energy efficient measures include:

- i) Inclusion of better U-values than the minimum U-values set in the ADL1A2010 document.
- ii) Designing for a buildings air permeability exceeding ADL1A2010 target values.
- iii) Utilising the highly efficient heating and hot water systems.
- iv) Utilising low energy efficient lighting such as LED lighting.

Heating Demand

The heating energy demand will be reduced by providing good insulation of the building envelope in order to minimise heat losses.

At the 'BE LEAN' stage a High Efficiency Air Source Heat Pump with Underfloor Heating has been examined. This strategy utilizes an Individual ASHP in the dwelling to provide heating and DHWS.

Ventilation

The dwelling will have a Mechanical Ventilation with Heat Recovery for fresh air to overcome condensation problems.

Lighting

The proposed light fittings will be low energy efficient fittings. These can be T5 fluorescent fittings with high frequency ballasts, or LED fittings.

The following table demonstrates the reduction in CO₂ emissions caused by the energy efficiency measures mentioned above.

Building Services	Baseline CO ₂ Emissions (kg CO ₂ /m ² /yr)	BE LEAN Building CO ₂ Emissions (kg CO ₂ /m ² /yr)
Heating	18.99	6.48
Auxiliary	0.05	1.97
Lighting	0.87	0.70
Hot Water	0.57	0.89
Total regulated emissions	21.12	10.03

Syntegra Consulting Ltd, Syntegra House, 63 Milford Road, RG1 8LG T: 08450091625
Registered Company No. 06408056 VAT Registration No. 98001604

E: mail@syntegra-epc.co.uk



CO₂ Reductions after BE LEAN stage

Regulated Emissions	Baseline CO ₂ Emissions	BE LEAN Building CO ₂ Emissions	% reduction in CO ₂ Emissions
kgr of CO ₂ /m ² /yr	21.12	10.03	
Tonnes CO ₂ / yr	34.140	16.217	52.5%

From the table above it can be seen that the overall CO₂ reduction due to energy efficiency is **52.5%** for the total emissions.

6. BE CLEAN – CHP & DECENTRALISED ENERGY NETWORKS

The energy hierarchy encourages the use of a CHP system and the connection to District Heating system to reduce CO₂ emissions further.

CHP

The Energy Hierarchy identifies combined heat and power (CHP) as a method of producing heat and electricity with much lower emissions than separate heat and power. Also, it encourages the creation of district heating systems supplied by CHP.

The implementation of a CHP strategy should be decided according to good practice design. Key factors for the efficient implementation of the CHP system are:

- Development with high heating load for the majority of the year.
- CHP operation based on maximum heat load for minimum 10 hours per day.
- CHP operation at maximum capacity of 90% of its operating period.

A CHP system will not be considered for this development due to the following reasons:

- The heating load of the building is not enough for the CHP system to run efficiently.
- Economic viability is heavily dependent on the demand for heat and power, as well as the price of electricity and gas. The heat and power demand of the proposed development is not sufficient for a CHP system to run efficiently

Hence, the implementation of a CHP strategy is not recommended for this development.

Micro - CHP

Micro CHP has not been considered further for this project for the following reasons:

Micro-CHP is a relatively new concept (Baxi Ecogen was made available in 2009) and issues are raised in relation to unproven technology, inefficiency for shorter run cycles and lack of technical knowledge that can limit the practical application of micro CHP at present. In addition other issues surrounding the fact that around 50% of electricity generated in domestic properties is surplus, high installation costs and estimated low life expectancy has also been taken into consideration as to its Offices, Doctor Surgery Unit & Communal Area un-viability for this development scheme. Micro-CHP also has lower FIT tariff rate and period duration and is only applicable for systems under 2kW.

Decentralised Energy Network

The feasibility of connecting into an existing heating network or providing the building with its own combined heat and power plant has been assessed alongside the **London Heat Map Study For Camden Council** as part of this assessment. The study does not identify the area in 10A Oakhill Avenue as a high potential area for a District Heating network. The development is not in close proximity to an existing nor a potential District Heating transmission line. At the moment there is no decentralized energy network available and in particular a district heating network in the proximity of

the proposed development site that would allow the development to connect to such a network. This is demonstrated clearly from the London Heat Map (<http://www.londonheatmap.org.uk>) snapshot below.

Site Location



Hence, the proposed development is not expected to be connected to a heat network.

7. BE GREEN – RENEWABLE ENERGY

In this section the viable renewable energy technologies that will reduce the development's CO₂ emissions further by 20% are examined. Incorporating lean design measures will significantly reduce the onsite energy consumption and the CO₂ emissions of the building however the reduction in emissions is still short of the target set out in the 'London Plan'. The 'London Plan' also states that a further CO₂ reduction of 20% must be achieved by the installation of renewable technologies. Below is a review of possible renewable technologies for incorporation in the proposed development.

All of the LZC technologies are assessed against a number of criteria. Hence, LZC technology feasibility will be assessed according to the following criteria:

- I. Renewable energy resource or fuel availability of the LZC technology on the site.
- II. Space limitations due to building design and urban location of the site.
- III. Capital, operating and maintenance cost.
- IV. Planning Permission
- V. Implementation with regards the overall M&E design strategy for building type

The renewable/LZC technologies which were found **non feasible** based on the above criteria are the following:

- Wind Turbines [See Appendix Section 10.1]
- Biomass Boilers [See Appendix Section 10.2]
- Hydrogen Fuel Cells [See Appendix Section 10.3]
- Small scale hydro power [See Appendix Section 10.4]
- Grd. Source Heat Pump (GSHP) [See Appendix Section 10.5]
- CHP & Micro CHP [See Appendix Section 10.6]
- Solar Thermal

7.1 PHOTOVOLTAIC (PV) – PROPOSED TECHNOLOGY

PV is the proposed renewable technology for this development. The PV system will provide self-generating electricity which can be sold back to the grid. The CO₂ reduction via renewables target is achieved with the implementation of PV. For the calculation of the payback period, the Feed-In-Tariffs' (FITs) has been taken into account. The PV load falls within the bracket associated with a FIT tariff applied of 13.50p per kWh for electricity generated and 4.64p per kWh for electricity exported back to the grid (over 20 years).

PV System specification

The PV system capacity for the development depends upon the selection of the two heating systems outlined at the 'BE LEAN' and 'BE CLEAN' stages of the energy hierarchy. Therefore, the amount of PV's relating to the proposed heating system option is outlined below:

- **Individual ASHP + Underfloor Heating + 7.85 kWp PV**

The tables below illustrate the site and the PV panels details:

Orientation	South
Panel Tilt	30°
Overshading	Less than 20 percent
Proportion Exported	50%
Build Type	New
Energy Efficiency	EPC valid and at least Band D or higher
Installation Type	Not a multi-installation

Number of Panels	24
Manufacturer	Sunpower
Model	SPR 327NE WHT D
Type	Monocrystalline
Area	1.631 m ²
Power Output	327 Wp

System Specification :	7.85 kWp
Total Roof Area Required :	39.15 m²
Annual Electricity Ouput :	6738.1 kWh

This table above shows that the proposed PV specification for the residential units. It will generate 6738.1kWh per year. For the 7.85 kWp system, 24 high efficiency 327W monocrystalline PV panels need to be installed. The roof area required for the PV panels is approximately 39.15m².

7.85 kWp Solar PV for ROI model below**Note: PV panels are based on high output, high efficiency at 327 Watts/panel.**

Investment in 7.82kWp System: *		£ 14,712.12
First	Income from Feed-In Generation Tariff @	
Year:	13.50p/kWh:	£ 878.93
	Income from exporting energy @ 4.64p/kWh:	£ 151.05
	Electricity Saving:	£ 468.76
	Total Benefit:	£ 1,498.73
Payback Time:		8y 6m

Total Profit Over 20 years:	£ 29,045.54
	9.87 % per year
	(5.45% AER)

Assumptions:

- Illustrative solar PV performance figures only. Figures are given in good faith but do not constitute "Financial Advice".
- Exact PV subsidy figures may depend on grants available at particular locations and other factors.
- Your property has an Energy Performance Certificate (EPC) rating of level D or better.
- Yearly PV output uses a factored degradation over time based on industry estimates.
- Tariffs shown presume installation after at the new FIT rates
- VAT is included (at 5% where appropriate) unless a new build is specified.
- Photovoltaic Panels will not be shaded (e.g. by Trees or Buildings) as shading affects PV output.
- Exact equipment costs are estimated based on retail prices in 2012 and will vary by installer/supplier.
- Installation costs are based on industry averages for installation type/size. Every install is different and you should obtain 3 quotes.
- Assuming that you pay 14.4p per unit and that around 35% of the solar electricity that you generate will be used in your home, having an export meter (you can change such assumptions above).

In order to qualify both the installer and the equipment must be certified under the Microgeneration Certification Scheme (MCS).

PV plant location(s) – To be located on the flat roof.

Syntegra Consulting Ltd, Syntegra House, 63 Milford Road, RG1 8LG T: 08450091625
 Registered Company No. 06408056 VAT Registration No. 98001604

E: mail@syntegra-epc.co.uk



CO₂ Emissions Reduction by PV

The table below demonstrate the results of the CO₂ emissions and energy use after the implementation of the PV technology. The target according to the London Plan 2011 is to meet a 20% reduction in CO₂ emissions from renewable technology.

The following tables demonstrate the reductions achieved by PV technology for the proposed heating option:

Individual ASHP + 7.85kWp PV BE GREEN stage

Building Services	BE LEAN CO ₂ Emissions (kg of CO ₂ /m ² /yr)	BE GREEN Building CO ₂ Emissions (kg of CO ₂ /m ² /yr)
Heating	6.48	6.48
Auxiliary	1.97	1.97
Lighting	0.70	0.70
Hot Water	0.89	0.89
Energy generated by renewables	-	-2.20
Total (regulated)	10.03	7.83

CO₂ Reductions after BE GREEN stage

Regulated Emissions	BE LEAN Building CO ₂ Emissions	BE GREEN Building CO ₂ Emissions	% reduction in CO ₂ Emissions
kg of CO ₂ /m ² /yr	10.03	7.83	
Tonnes CO ₂ / yr	16.217	12.653	22%

From the table above it can be seen that the overall CO₂ reduction due to energy efficiency is **22%** for the total emissions.

8. Conclusion

Due to the site spatial limitations, location and the other issues identified previously in the report technologies such as Ground Source Heat Pump, Biomass, Solar Thermal, Hydroelectricity and Wind turbines are immediately unfeasible. The design has incorporated building fabric enhancement (above current building regs requirements) to increase the energy efficiency of the building.

The recommendation for the proposed development at **10A Oakhill Avenue, London, NW3 7RE**, is that an **Efficient ASHP with Underfloor heating and a total of 7.85kWp PV, which equals to 24PV panels in total (based on 327W PV output) and approximately 39.15 m² required roof area** should be progressed. This is based on the following reasons:

1. PV plant location(s) – The plant would be located on the flat roof. The PV panels are based on high output, high efficiency Sunpower 327 watts. PV layouts and allocation of roof areas are yet to be finalised.
2. The strategy would provide **an average of 62.9% CO₂ reduction saving (DER/TER) against current building regulations for the whole development. Therefore, the strategy meets BRUK-L1A requirements for the development and the minimum requirements for ENE01 – Level 4 for CSH assessment.**
3. The strategy would provide an average of **22% reduction of CO₂ emissions the energy demand via onsite renewable technology (PV) for the overall development. Hence, the required target of 20% reduction in CO₂ emissions through renewable onsite has been achieved.**
4. The strategy achieves an average of 10.13% reduction of CO₂ emissions over the standard case SAP assessments thus enabling 1 credit to be awarded in the ENE07 section of the CSH report.
5. The strategy would provide an average **Fabric Energy Efficiency of 50.97. Therefore, 5.3 credits can be awarded under ENE02 section of the CSH report.**
6. A separate CSH pre-assessment has been undertaken for the residential development. **The CSH pre-assessment demonstrates that a “Code Level 4” rating can be achieved for the dwelling.** [See the Appendix for the CSH pre-assessment report]

7. After the application of the Energy Hierarchy, the regulated carbon dioxide emissions are presented on the table below:

	Carbon Dioxide emissions (Tonnes CO ₂ per annum)
	Regulated
Baseline: Building Regulations 2010 Part L Compliant Development	34.140
After energy demand reduction	16.217
After CHP/ Communal Heating	16.217
After renewable energy	12.653

The chart below summarises the regulated carbon dioxide savings from each stage of the Energy Hierarchy:

	Regulated Carbon Dioxide savings	
	(Tonnes CO ₂ per annum)	(%)
Savings from energy demand reduction	17.923	52.5%
Savings from CHP/ Communal Heating	0	0%
Savings from Renewable energy	3.564	22%
Total Cumulative Savings	21.487	62.9%
Total Target Savings	8.102	40%
Annual Surplus	13.385	

9. Appendix

- Low Zero Carbon Energy Systems
- SAP checklist
- CSH pre-assessment

Syntegra Consulting Ltd, Syntegra House, 63 Milford Road, RG1 8LG T: 08450091625
Registered Company No. 06408056 VAT Registration No. 98001604

E: mail@syntegra-epc.co.uk



10. Low & Zero Carbon Energy Systems

The following section is an overview of the LZC energy systems that are available and can be implemented to the building environment. Firstly, a brief description of the types of renewable energy (zero carbon energy) that can be harnessed with technology will be presented. In addition, the renewable energy system technologies that harness the renewable energy and convert it to electricity, heating and hot water etc, to be consumed in buildings will be presented as well.

The second part of this section will provide an indication of the available low carbon technologies that can be installed on a building to minimise carbon emissions and reduce energy costs.

10.1. Zero Carbon (Renewable) Energy Overview.

Renewable energy is the energy that is grasped by the earth's abundant natural sources. Renewable energy can be harnessed with the appropriate use of technology to satisfy the human energy needs. Solar, wind, wave, tide and bio energy are termed as renewable. These renewable energy sources can be classified as 'active' or 'passive'. Active RES are the renewable sources which with the use of renewable energy systems technology (REST) can generate power and heat to satisfy the energy and heating demands of buildings. Passive RES are the renewable sources which with the use of static building elements can enhance the natural ventilation and the heating of a building.

Solar Energy

Solar energy is the energy of sun light. The temperature of the Sun's surface reaches to a value of approximately 5,762K. The Earth's perimeter of 40,000 km results in an intersected sun power of 174,000TW. Attenuation by the atmosphere results in peak intensity at sea level of around 1kW/m², giving a 24 hour annual average of 0.2kW/m² and a 24 hour annual average power of 102,000 TW.

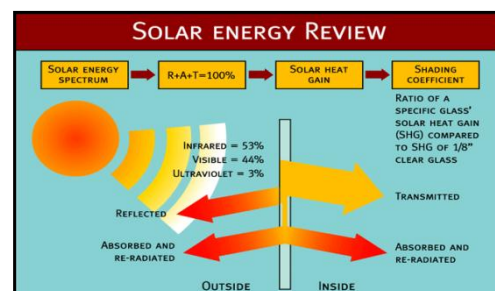

This commands the environment and maintains the life support system of Earth's ecosystem and all forms of renewable energy with the exception of geothermal energy. The solar energy reaching the earth's surface surpasses 10,000 times the current global energy demand.

To be more specific in terms of harnessing solar energy we are interested with the irradiance. Irradiance is the energy of light incident on a solar collector. Irradiance is measured in energy per area, (W/m²). The solar irradiance received on the Earth's surface consists of three components, the beam irradiance, diffuse and ground reflected irradiance. The beam component is the irradiance that reaches the solar collector directly. The diffuse irradiance is formulated due to scattering and absorption in the earth's atmosphere. Finally, the ground reflected irradiance is formed due to the sunlight reflected by the earth's ground.

Wind Energy

Syntegra Consulting Ltd, Syntegra House, 63 Milford Road, RG1 8LG T: 08450091625
Registered Company No. 06408056 VAT Registration No. 98001604

E: mail@syntegra-epc.co.uk



Wind energy is the energy found in the wind that is grasped by REST in order to generate power for human benefit. Wind turbines are the REST used to collect the wind resource and generate power. Today, wind turbines are used to generate electricity from the wind. There are two types of wind turbines, the horizontal axis turbine which is the most common one and the vertical axis turbine. The HAWT is the most efficient and cost effective. Most of the wind turbines used for electricity generation is of this type. Wind turbines can be found in many sizes and outputs, from small battery charging turbines (say a rotor diameter of 1 or 2 metres with an output of a few hundred Watts) to the largest machines used to supply electricity to the grid (Rotor diameters in excess of 70m and output powers of over two MW).



Bio-energy

Bio-energy is the energy produced from biomass. Biomass is available from materials derived from biological sources. Biomass is any organic material which has stored sunlight in the form of chemical energy. As a fuel it may include wood, wood waste, straw, manure, sugar cane, and many other by products from a variety of agricultural processes. Energy from biomass is produced by burning organic matter.

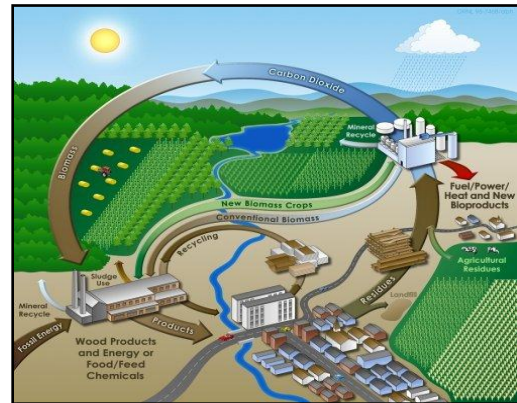

Biomass is the solid form of 'bioenergy', but liquid fuels can also be generated from plant matter and this is referred to as 'biofuel'. Biomass is carbon-based so when used as fuel it also generates carbon emissions.

However, the carbon that is released during combustion is equivalent to the amount that was absorbed during growth, and so the technology is carbon-neutral.

Geothermal Energy

Geothermal energy is the heat from the Earth. It's clean and sustainable. Resources of geothermal energy range from the shallow ground to hot water and hot rock found a few miles beneath the Earth's surface, and down even deeper to the extremely high temperatures of molten rock called magma. Almost everywhere, the shallow ground or upper 10 feet of the Earth's surface maintains a nearly constant temperature between 10° and 16°C. Geothermal heat pumps can tap into this resource to heat and cool buildings. A geothermal heat pump system consists of a heat pump, an air delivery system (ductwork), and a heat exchanger—a system of pipes buried in the shallow ground near the building. In the winter, the heat pump removes heat from the heat exchanger and pumps it into the indoor air delivery system. In the summer, the process is reversed, and the heat pump moves heat from the

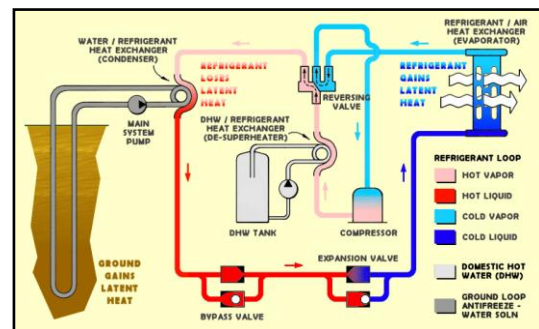

Syntegra Consulting Ltd, Syntegra House, 63 Milford Road, RG1 8LG T: 08450091625

E: mail@syntegra-epc.co.uk

Registered Company No. 06408056

VAT Registration No. 98001604



indoor air into the heat exchanger. The heat removed from the indoor air during the summer can also be used to provide a free source of hot water.

10.2 Zero Carbon Technologies

In this section the zero carbon technologies also known as Renewable Energy System Technologies (REST) are described.

- Photovoltaics (PV)
- Solar Water Heating
- Wind Turbines
- Small scale Hydro Power
- Biomass Heating

10.2.1 Photovoltaic Systems

Description of PV Systems

Photovoltaic systems convert energy from the sun directly into electricity. They are composed of photovoltaic cells, usually a thin wafer or strip of semiconductor material that generates a small current when sunlight strikes them. Multiple cells can be assembled into modules that can be wired in an array of any size. These flat-plate PV arrays can be mounted at a fixed angle facing south, or they can be mounted on a tracking device that follows the sun, allowing them to capture the most sunlight over the course of a day, or even in the form of a solar PV facade. Several connected PV arrays can provide enough power for a household/building.



Thin film solar cells use layers of semiconductor materials only a few micrometers thick. Thin film technology has made it possible for solar cells to now double as rooftop shingles, roof tiles, building facades, or the glazing for skylights or atria. The solar cell version of items such as shingles offer the same protection and durability as ordinary asphalt shingles.



Advantages

The PV systems are relatively simple, modular, and highly reliable due to the lack of moving parts. Moreover, PV systems do not produce any greenhouse gases, on the contrary they save approximately 325kg of CO₂ per year kWp they generate.

Best Practice Design

PV installations performance is proportional to the active area (area covered by PVs). The desirable location for PV panels is on a south facing roof or façade, as long as no other building or tall trees overshadows it,



Syntegra Consulting Ltd, Syntegra House, 63 Milford Road, RG1 8LG T: 0845009
Registered Company No. 06408056 VAT Registration No. 951 1234 567

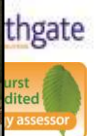

resulting in reduced PV efficiency. PV panels are require strong structurally roofs due to their heavy weight, especially if the panels are placed on top of existing tiles. The area of PV panels required to generate 1 kWp varies but generally 6-8m² for mono-crystalline and 10m² for polycrystalline panels will generate 1kWp(kWp-energy generated at full sunlight) of electricity.

Cost & Maintenance

Prices for PV systems vary, depending on the size of the system to be installed, type of PV cell used and the nature of the actual building on which the PV is mounted. The size of a PV system depends on the buildings electricity demand. For an average domestic system, costs of a PV system can be around £4000 - £9000 per kWp installed, with most domestic systems usually between 1.5 and 2 kWp. Solar tiles cost more than conventional panels, and panels that are integrated into a roof are more expensive than those that sit on top. Grid connected systems require very little maintenance, generally limited to ensuring that the panels are kept relatively clean and that shade from trees does not obstruct the sunlight path. However, the wiring and system components should be checked regularly by a qualified technician.

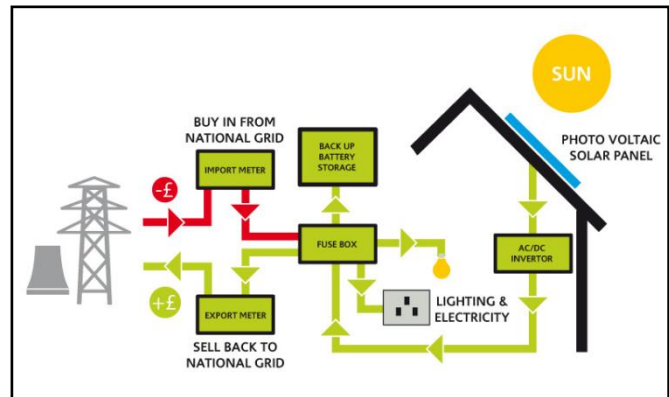

Grid connected systems require very little maintenance, generally limited to ensuring that the panels are kept relatively clean and that shade from trees does not obstruct the sunlight path. However, the wiring and system components should be checked regularly by a qualified technician.

Available Grants

The Feed - In - Tariffs have been introduced in order to give an incentive for PV generated electricity. The Feed-In-Tariffs scheme is based on the principle that the energy supplier pays generation tariff for every kWh the PV system generates and an export tariff for every kWh of electricity supplied back to the national grid.

Tariff level for new Solar PV in stallations after 1st August 2012 (pence/kWh). For non PV technologies there will be new rates as of October 2012

Technology	Scale	Standard generation tariff	Multi-installation tariff	Lower tariff if energy efficiency requirement not met
PV	≤4 kW (new build)	16.0	14.4	7.1
PV	≤4 kW (retrofit)	16.0	14.4	7.1
PV	>4-10 kW	14.5	13.05	7.1
PV	Stand alone system	7.1	N/A	N/A

10.2.2 Solar Water Heating

Description of Solar Water Heating System

Solar water heating systems use solar energy to heat water. Depending on the type of solar collector used, the weather conditions, and the hot water demand, the temperature of the water heated can



Syntegra Consulting Ltd, Syntegra House, 63 Milford Road, RG1 8LG T: 08450091625
 Registered Company No. 06408056 VAT Registration No. 98001604

E: mail@syntegra-epc.co.uk



vary from tepid to nearly boiling. Most solar systems are meant to furnish 20 to 85% of the annual demand for hot water, the remainder being met by conventional heating sources, which either raise the temperature of the water further or provide hot water when the solar water heating system cannot meet demand.

Solar systems can be used wherever moderately hot water is required. Off-the-shelf packages provide hot water to the bathroom and kitchen of a house; custom systems are designed for bigger loads, such as multi-unit apartments.

The most common collector is called a flat-plate collector. Mounted on the roof, it consists of a thin, flat, rectangular box with a transparent cover that faces the sun. Small tubes run through the box and carry the fluid – either water or other fluid, such as an antifreeze solution – to be heated. The tubes are attached to an absorber plate, which is painted black to absorb the heat. As heat builds up in the collector, it heats the fluid passing through the tubes.

Advantages

Solar water heating can provide about a third of a typical dwellings/business hot water needs. The average domestic system reduces CO₂ by 325 kg per year approximately and around £50 a year of hot water bills, when installed in a gas heated home.

Fuel Displaced	£ Saving per year	CO ₂ saving per year kg
Gas	50	325
Electricity	80	635

Table 4

The savings presented on the previous table are approximate and are based on the hot water heating demand of a 3 bed semi detached house.

Best Design Practice

For domestic systems a 3-4 m² of southeast to southwest facing roof receiving direct sunlight for the main part of the day is required. Also, more space will be needed if a water cylinder is required.

Planning Issues

In England, changes to permitted development rights for micro generation technologies introduced on 6th April 2008 have lifted the requirements for planning permission for most solar water heating installations. Roof mounted and stand alone systems can now be installed in most dwellings, as long as they follow certain size criteria. Listed, English Heritage and buildings in conservation areas are exempted.

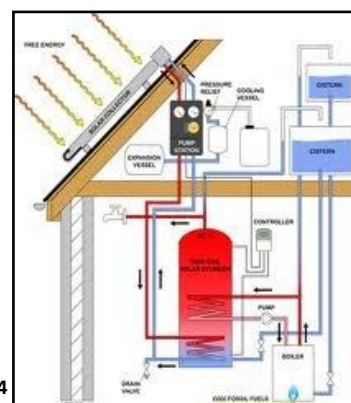

Syntegra Consulting Ltd, Syntegra House, 63 Milford Road, RG1 8LG T: 08450091625
Registered Company No. 06408056 VAT Registration No. 98001604

Cost & Maintenance

A typical installation cost for a domestic SHW system is £3000-£5000. Evacuated tube systems are more expensive due to their higher manufacturing cost.

SWH systems in general have a 5-10 years warranty and require little maintenance. A yearly check by the owner of the system and a more detailed maintenance check by a qualified installer every 3-5 years should be adequate.

Available Grants

In March 2011, the UK Government announced the details of their Renewable Heat Incentive (RHI). RHI is designed to provide financial support that encourages individuals, communities and businesses to switch from using fossil fuel for heating, to renewables such as wood fuel.

There will be two phases for domestic customers:

Phase 1 (available from July 2011) - “RHI Premium Payment”

This is called the “RHI Premium Payment” and will be worth around £15m and available to 25,000 householders in Great Britain who install from July 2011.

The exact amounts available to consumers are confirmed:

- * Solar Thermal - £300/unit

These are one off payments; so not annual. DECC plan to publish details of the “Phase 2 RHI Payment” and how this will apply next year. Recipients of this payment will need to ensure that:

- * They have a well-insulated property based on its energy performance certificate;
- * They agree to give feedback on how the equipment performs.

Phase 2 (available from October 2012) – RHI tariffs

People in receipt of the Renewable Heat Premium Payments will be able to receive long term RHI tariff support once these tariffs are introduced, as will anybody who has installed an eligible technology since 15th July 2009.

These tariff payments will start alongside the Green Deal from October 2012 to allow a more whole-house approach to heat production and energy saving.

10.2.3 Wind Turbines

Description of Wind Turbine

Wind energy systems convert the kinetic energy of moving air into electricity or mechanical power. They can be used to provide power to central grids or



Syntegra Consulting Ltd, Syntegra House, 63 Milford Road, RG1 8LG T: 0845 300 0000
Registered Company No. 06408056 VAT Registration No. 248 450 123



isolated grids, or to serve as a remote power supply or for water pumping. Wind turbines are Offices, Doctor Surgery Unit & Communal Arealy available in a vast range of sizes. The turbines used to charge batteries and pump water off-grid tend to be small, ranging from as small as 50 W up to 10 kW. For isolated grid applications, the turbines are typically larger, ranging from about 10 to 200 kW. Wind turbines are mounted on a tower to harness the most energy. At 30 meters or more aboveground, they can capture the faster and less turbulent wind in an urban environment. Turbines harness the wind's energy with their propeller-like blades. In most of the cases, two or three blades are mounted on a shaft to form a rotor.

There are two types of wind turbines that can be used for buildings:

- Mast mounted – which are free standing and located near the building that will be consuming the generated electricity.
- Roof Mounted – which can be installed on house roofs and other buildings.

Planning Issues

Planning issues such as visual impact, noise and conservation issues also have to be considered. System installation normally requires permission from the local authority.

Cost & Maintenance

- Roof mounted turbines cost from £3000. The amount of energy and carbon that roof top micro wind turbines save depends on size, location, wind speed, nearby buildings and the local landscape. At the moment there is not enough data from existing wind turbine installations to provide a figure of how much energy and CO₂ could typically be saved. The Energy saving trust is monitoring up to 100 installations nationwide which will give ball park figures of carbon savings.
- Mast Mounted turbines in the region of 2.5kW to 6kW would cost approximately £11000-£19000. These costs are inclusive of the turbine, mast, inverters, battery storage and installation cost. It should be noted that these costs vary depending on location, size and type of system to be installed.
- Turbines have an operational lifetime of up to 22.5 years but require service checks every few years to ensure efficient operation. For battery storage systems, typical battery life is around 6-10 years, depending on the type, so batteries may have to be replaced at some point in the system's life.

Available Grants

The Feed - In – Tariffs have been introduced in order to give an incentive for wind generated electricity. The Feed-In-Tariffs scheme is based on the principle that the energy supplier pays generation tariff for every kWh the wind system generates and an export tariff for every kWh of electricity supplied back to the national grid.

- Generation Tariff: 28.0 – 36.20 pence/kWh depending on installed rated output (up to 15KW)

Syntegra Consulting Ltd, Syntegra House, 63 Milford Road, RG1 8LG T: 08450091625

E: mail@syntegra-epc.co.uk

Registered Company No. 06408056

VAT Registration No. 98001604



- Export Tariff: 3.10pence/kWh
- Tariff period duration is 20 yea

10.2.4 Small Scale Hydro

Description of Small scale Hydro System

Small hydro systems convert the potential and kinetic energy of moving water into electricity, by using a turbine that drives a generator. As water moves from a higher to lower elevation, such as in rivers and waterfalls, it carries energy with it; this energy can be harnessed by small hydro systems. Used for over one hundred years, small hydro systems are a reliable and well-understood technology that can be used to provide power to a central grid, an isolated grid or an off-grid load, and may be either run-of-river systems or include a water storage reservoir.



In a residential small scale hydro system the constant flow of water is critical to the success of the project. The energy available from a hydro turbine is proportional to the flow rate of the water and the head height. Since the majority of the cost of a small hydro project stems from up front expenses in construction and equipment purchase, a hydro project can generate large quantities of electricity with very low operating costs and modest maintenance expenditures for 50 years or longer.

Advantages

For houses with no mains connection but with access to a micro hydro site, a good hydro system can generate a steady, more reliable electricity supply than other renewable technologies at lower cost. Total system costs can be high but often less than the cost of a grid connection and with no electricity bills to follow.

Cost & Maintenance

Small hydro schemes are very site specific and are related to energy output. For low head systems, costs may lie in the region of £4,000 per kW installed up to about 10kW and would drop per kW for larger schemes.

For medium heads, there is a fixed cost of about £10,000 and about £2,500 per kW up to around 10kW – so a typical 5kW domestic scheme might cost £20-£25,000.

Unit costs drop for larger schemes. Maintenance costs vary but small scale hydro systems are very reliable.

Available Grants

The Feed - In – Tariffs have been introduced in order to give an incentive for hydroelectric generated electricity. The Feed-In-Tariffs scheme is based on the principle that the energy supplier pays generation tariff for every kWh the hydroelectric system generates and an export tariff for every kWh of electricity supplied back to the national grid.

Syntegra Consulting Ltd, Syntegra House, 63 Milford Road, RG1 8LG T: 08450091625
Registered Company No. 06408056 VAT Registration No. 98001604

E: mail@syntegra-epc.co.uk



- Generation Tariff: 20.90 pence/kWh depending on installed rated output (up to 15KW)
- Export Tariff: 3.10pence/kWh
- Tariff period duration is 20 years

10.2.5 Biomass Heating

Description of Biomass Heating System

Biomass heating systems also known as biomass boilers burn organic matter—such as wood chips, agricultural residues or municipal waste—to generate heat for buildings. They are highly efficient heating systems, achieving near complete combustion of the biomass fuel through control of the fuel and air supply, and often incorporating automatic fuel handling transport systems. Biomass boilers consist of a boiler, a heat distribution system, and a fuel transportation system. The biomass heating system typically makes use of multiple heat sources, including a waste heat recovery system, a biomass combustion system, a peak load boiler, and a back-up boiler. The heat distribution system conveys hot water or steam from the heating plant to the loads that may be located within the same building as the heating plant, as in a system for a single institutional or industrial building, or, in the case of a “district heating” system, clusters of buildings located in the vicinity of the heating plant.



Biomass heating systems have higher capital costs than conventional boilers and need diligent operators. Balancing this, they can supply large quantities of heat on demand with very low fuel costs, depending on the origin of the fuel.

Best Design Practice

It's important to have storage space for the fuel and appropriate access to the boiler for loading the fuel. A local fuel supplier should be present in order to make the scheme viable.

The vent material must be specifically designed for wood appliances and there must be sufficient air movement for proper operation of the stove. Chimneys can be fitted with a lined flue.

A Biomass heating system installation should comply with all safety and building regulations. Wood can only be burned in exempted appliances, under the Clean Air Act.

Advantages

Producing energy from Biomass has both environmental and economic advantages. Although Biomass produces CO₂ it only releases the same amount that is absorbed whilst growing, which is why it is considered to be carbon neutral. Furthermore, Biomass can contribute to waste management by harnessing energy from products that are often disposed at landfill sites.

It is most cost effective and sustainable when a local fuel source is used, which results in local investment and employment, which in addition minimizes transport emissions.

Syntegra Consulting Ltd, Syntegra House, 63 Milford Road, RG1 8LG T: 08450091625

E: mail@syntegra-epc.co.uk

Registered Company No. 06408056

VAT Registration No. 98001604



Planning Issues

If the building is listed or is in an area of outstanding natural beauty, then it is required that the Local Authority Planning department is notified before a flue is fitted.

Cost & Maintenance

Stand alone room heaters cost £2,000 to £4,000. Savings will depend on how much they are used and which fuel you are replacing. A Biomass stove which provides a detached home with 10% of annual space heating requirements could save around 840kg of CO₂ when installed in an electrically heated home. Due to the higher cost of Biomass pellets compared with other heating fuels, and the relatively low efficiency of the stove compared to a central heating system it will cost more to run.

The cost of Biomass boilers varies depending on the system choice; a typical 15kW pellet boiler would cost about £5,000-£14,000 installed, including the cost of the flue and commissioning process. A manual log feed system of the same size would be slightly cheaper. A wood pellet boiler could save around £750 a year in energy bills and around 6 tons of CO₂ per year when installed in an electrically heated home.

In terms of biomass fuel costs, they generally depend on the distance between the dwelling and the supplier and whether large quantities can be bought.

Available Grants

In March 2011, the UK Government announced the details of their Renewable Heat Incentive (RHI). RHI is designed to provide financial support that encourages individuals, communities and businesses to switch from using fossil fuel for heating, to renewables such as wood fuel.

The RHI is in two phases:

Phase 1 (available from July 2011) - "RHI Premium Payment"

This is called the "RHI Premium Payment" and will be worth around £15m and available to 25,000 householders in Great Britain who install from July 2011.

The exact amounts available to consumers have yet to be confirmed. However the Department of Energy and Climate Change (DECC) have announced that the following amounts may be available:

- * Biomass boilers - £950/unit (available only to off-gas installations)

These are one off payments; so not annual. DECC plan to publish details of the "Phase 2 RHI Payment" and how this will apply next year. Recipients of this payment will need to ensure that:

- * They have a well-insulated property based on its energy performance certificate;
- * They agree to give feedback on how the equipment performs.

Syntegra Consulting Ltd, Syntegra House, 63 Milford Road, RG1 8LG T: 08450091625
Registered Company No. 06408056 VAT Registration No. 98001604

E: mail@syntegra-epc.co.uk



Phase 2 (available from October 2012) – RHI tariffs

People in receipt of the Renewable Heat Premium Payments will be able to receive long term RHI tariff support once these tariffs are introduced, as will anybody who has installed an eligible technology since 15th July 2009.

These tariff payments will start alongside the Green Deal from October 2012 to allow a more whole-house approach to heat production and energy saving.

10.3 Low Carbon Technologies

In this section the low carbon technologies are described.

- Air Source Heat Pumps
- Ground Source Heat Pumps (GSHP)
- Combined Heat and Power (CHP)
- Micro CHP
- Fuel Cells

10.3.1. Air Source Heat Pumps (ASHP)

Description of Air Source Heat Pumps

Air source heat pumps work in a very similar way to fridges and air conditioners and absorb heat from the air. They are ideally suited to work with under floor heating systems because of the lower design temperatures of under floor systems. The lower the water temperature, the higher the COP. Air source heat pumps use air. They are fitted outside a house; generally perform better at slightly warmer air temperatures. The seasonal efficiencies of air source heat pumps are between 200% - 400%. Heat pumps can operate at outside temperatures down to -15 degC, although there is a drop in COP.



Advantages

- A reduction in carbon emission.
- No boiler flues and danger of carbon monoxide leakage.
- Maintenance is carried outside the premises.
- No annual boiler servicing and safety checks.
- Heat pump life expectancy about 25 years compared to a boiler of 15 years



Costs & Savings

Operating Cost Savings around 15% in comparison with a typical gas fired condensing boiler installation with HWS cylinder and an electrically driven Community air to water heat pump.

Available Grants

In March 2011, the UK Government announced the details of their Renewable Heat Incentive (RHI).

RHI is designed to provide financial support that encourages individuals, communities and businesses to switch from using fossil fuel for heating, to renewables such as wood fuel.

The RHI is in two phases:

Phase 1 (available from July 2011) - "RHI Premium Payment"

This is called the "RHI Premium Payment" and will be worth around £15m and available to 25,000 householders in Great Britain who install from July 2011.



The exact amounts available to consumers are confirmed:

- * Air Source Heat Pumps - £850/unit (available only for off-gas installations)

These are one off payments; so not annual. DECC plan to publish details of the "Phase 2 RHI Payment" and how this will apply next year. Recipients of this payment will need to ensure that:

- * They have a well-insulated property based on its energy performance certificate;
- * They agree to give feedback on how the equipment performs.

Phase 2 (available from October 2012) – RHI tariffs

People in receipt of the Renewable Heat Premium Payments will be able to receive long term RHI tariff support once these tariffs are introduced, as will anybody who has installed an eligible technology since 15th July 2009.

Whilst Air source heat pumps will be eligible for the Renewable Premium Payment, a decision on whether or not they'll be included in the tariff payments will be based upon consumer feedback on the performance of the technologies. This should be clarified towards the end of 2011.

These tariff payments will start alongside the Green Deal from October 2012 to allow a more whole-house approach to heat production and energy saving.

Syntegra Consulting Ltd, Syntegra House, 63 Milford Road, RG1 8LG T: 08450091625
Registered Company No. 06408056 VAT Registration No. 98001604

E: mail@syntegra-epc.co.uk



10.3.2 Ground Source Heat Pumps (GSHP)

Description of Ground Source Heat Pumps

Ground-source heat pumps provide low temperature heat by extracting it from the ground or a body of water and provide cooling by reversing this process. Their principal application is space heating and cooling, though many also supply domestic hot water. They can even be used to maintain the integrity of building foundations in permafrost conditions, by keeping them frozen through the summer.

A ground-source heat pump (GSHP) system has three major components: the earth connection, a heat pump, and the heating or cooling distribution system. The earth connection is where heat transfer occurs. One common type of earth connection comprises tubing buried in horizontal trenches or vertical boreholes, or alternatively, submerged in a lake or pond. An antifreeze mixture, water or another heat-transfer fluid is circulated from the heat pump, through the tubing, and back to the heat pump in a “closed loop.” “Open loop” earth connections draw water from a well or a body of water, transfer heat to or from the water, and then return it to the ground or the body of water.

Since the energy extracted from the ground exceeds the energy used to run the heat pump, GSHP “efficiencies” can exceed 100%, and routinely average 200 to 500% over a season. Due to the stable, moderate temperature of the ground, GSHP systems are more efficient than air-source heat pumps, which exchange heat with the outside air. GSHP systems are also more efficient than conventional heating and Air-conditioning technologies, and typically have lower maintenance costs. They require less space, especially when a liquid building loop replaces voluminous air ducts, and, since the tubing is located underground, are not prone to vandalism like conventional rooftop units. Peak electricity consumption during cooling season is lower than with conventional air-conditioning, so utility demand charges may be reduced. Heat pumps typically range in cooling capacity from 3.5 to 35 kW (1 to 20 tons of Cooling). A single unit in this range is sufficient for a house or small Offices, Doctor Surgery Unit & Communal Area Building. The heat pump usually generates hot or cold air to be distributed locally by conventional ducts.

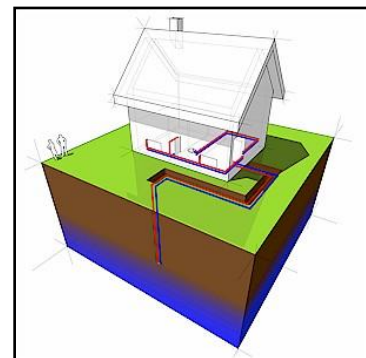

Advantages

The efficiency of GSHP system is measured by the coefficient of performance (COP). This is the ratio of units of heat output for each unit of electricity used to drive the compressor and pump for the ground loop. Average COP known as seasonal efficiency, is around 3-4 although some systems may produce a greater rate of efficiency. This means that for every unit of electricity used to pump the heat, 3-4 units of heat are produced, making it an efficient way of heating a building. If grid electricity is used for the compressor and pump, then a range of energy suppliers should be consulted in order to benefit from the lower running costs.

Cost & Savings

A typical 8-12kW system costs £6,000-£12,000 (not including the price of distribution system). This can vary with property and location. When installed in an electrically heated home a GSHP could save as much as £900 a year on heating bills and almost 7 tonnes of CO₂ a year. Savings will vary depending on what fuel is being replaced.

Available Grants

In March 2011, the UK Government announced the details of their Renewable Heat Incentive (RHI). RHI is designed to provide financial support that encourages individuals, communities and businesses to switch from using fossil fuel for heating, to renewables such as wood fuel.

There will be two phases for domestic customers:

Phase 1 (available from July 2011) - "RHI Premium Payment"

This is called the "RHI Premium Payment" and will be worth around £15m and available to 25,000 householders in Great Britain who install from July 2011.

The exact amounts available to consumers are confirmed:

*Ground Source Heat Pumps - £1,250/unit (available for off-gas installations only)

These are one off payments; so not annual. DECC plan to publish details of the "Phase 2 RHI Payment" and how this will apply next year. Recipients of this payment will need to ensure that:

- * They have a well-insulated property based on its energy performance certificate;
- * They agree to give feedback on how the equipment performs.

Phase 2 (available from October 2012) – RHI tariffs

People in receipt of the Renewable Heat Premium Payments will be able to receive long term RHI tariff support once these tariffs are introduced, as will anybody who has installed an eligible technology since 15th July 2009.

These tariff payments will start alongside the Green Deal from October 2012 to allow a more whole-house approach to heat production and energy saving

10.3.3 Combined Heat and Power (CHP) & Micro CHP

Description of CHP

The principle behind combined heat and power (cogeneration) is to recover the waste heat generated by the combustion of a fuel in an electricity generation system. This

Syntegra Consulting Ltd, Syntegra House, 63 Milford Road, RG1 8LG T: 08450091625
Registered Company No. 06408056 VAT Registration No. 9800160



heat is often rejected to the environment, thereby wasting a significant portion of the energy available in the fuel that can otherwise be used for space heating and cooling, water heating, and industrial process heat and cooling loads in the vicinity of the plant. This cogeneration of electricity and heat greatly increases the overall efficiency of the system, anywhere from 25-55% to 60-90% depending on the equipment used, and the application.

A CHP installation comprises four subsystems: the power plant, the heat recovery and distribution system, an optional system for satisfying heating and/or cooling loads and a control system. A wide range of equipment can be used in the power plant, with the sole restriction being that the power equipment rejects heat at a temperature high enough to be useful for the thermal loads at hand. In a CHP system, heat may be recovered and distributed as hot water, conveyed from the plant to low temperature thermal loads in pipes for domestic hot water, or for space heating.

Advantages

CHP can significantly reduce primary energy consumption, and can therefore have a major impact on CO₂ emissions associated with the combustion of fossil fuels in conventional boilers. Each 1 kW of electrical capacity provided by CHP plant using fossil fuels has the potential to reduce annual CO₂ emissions by around 0.6 tonnes compared to gas-fired boilers and fully grid-derived electricity. For plant which is fuelled by renewable energy sources the potential is much greater.

Costs & Savings

Capital costs for CHP installations are higher than for alternative systems, but this can be recovered over a relatively short period of time (typically 5–10 years) for installations where there is a demand for heat and power for 4500 hours or more each year. The cost effectiveness is very sensitive to the relative price of electricity and fossil fuel which have been subject to frequent variations since deregulation of the energy supply industries.

Micro CHP

Micro CHP (Combined Heat & Power) is the simultaneous production of useful heat and power within the home. It works very much like the gas boiler in a central heating system and heats the home in just the same way. However, at the same time it generates electricity, some of which will be used in the dwelling and the remainder will be exported to the electricity grid. Effectively the micro CHP unit replaces the gas central heating boiler and provides heat and hot water as usual, but additionally provides the majority of the home's electricity needs. Although individual units produce, by definition, relatively small amounts of electricity, the significance of micro CHP lies in the potentially huge numbers of systems which may ultimately be installed in the millions of homes in the UK where natural gas is currently the dominant heating fuel.



Available grants

Syntegra Consulting Ltd, Syntegra House, 63 Milford Road, RG1 8LG T: 08450091625
Registered Company No. 06408056 VAT Registration No. 98001604

E: mail@syntegra-epc.co.uk



The Feed - In – Tariffs have been introduced in order to give an incentive for micro CHP generated electricity. The Feed-In-Tariffs scheme is based on the principle that the energy supplier pays generation tariff for every kWh the micro CHP system generates and an export tariff for every kWh of electricity supplied back to the national grid.

- Generation Tariff: 10.50 pence/kWh depending on installed rated output (up to 2KW)
- Export Tariff: 3.10pence/kWh
- Tariff period duration is 10 years

10.3.4 Fuel Cells

Description of Fuel Cells

A fuel cell is a device that generates more electricity by a chemical reaction. Every fuel cell has two electrodes, one positive and one negative, called, respectively, the anode and cathode. The reactions that produce electricity take place at the electrodes.

Every fuel cell also has an electrolyte, which carries electrically charged particles from one electrode to the other, and a catalyst, which speeds the reactions at the electrodes. Hydrogen is the basic fuel, but fuel cells also require oxygen.

One great appeal of fuel cells is that they generate electricity with very little pollution—much of the hydrogen and oxygen used in generating electricity ultimately combine to form a harmless by product, namely water.

Fuel Cell Operation

The purpose of a fuel cell is to produce an electrical current that can be directed outside the cell to do work, such as powering an electric motor or illuminating a light bulb or a city. Because of the way electricity behaves, this current returns to the fuel cell, completing an electrical circuit. The chemical reactions that produce this current are the key to how a fuel cell works.

There are several kinds of fuel cells, and each operates a bit differently. But in general terms, hydrogen atoms enter a fuel cell at the anode where a chemical reaction strips them of their electrons. The hydrogen atoms are now “ionized,” and carry a positive electrical charge. The negatively charged electrons provide the current through wires to do work. If alternating current (AC) is needed, the DC output of the fuel cell must be routed through a conversion device called an inverter.

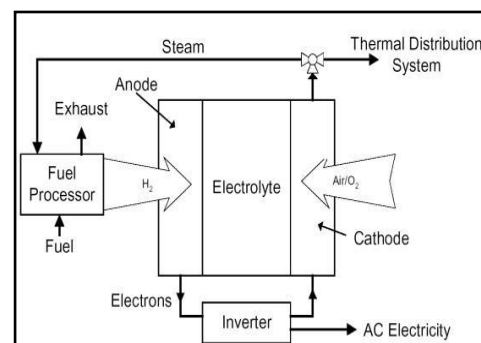

Advantages

Even better, since fuel cells create electricity chemically, rather than by combustion, they are not subject to the thermodynamic laws that limit a conventional power plant. Therefore, fuel cells are

more efficient in extracting energy from a fuel. Waste heat from some cells can also be harnessed, boosting system efficiency still further.

Fuel Cells with Hydrogen from Renewable Sources

Fuel cells can be used as CHP systems in buildings. There are currently several different systems under development using different chemical processes, which operate at different temperatures. They currently use natural gas as the fuel, which is reformed to produce hydrogen, the required fuel for the fuel cell. When and if hydrogen becomes available from renewable energy, fuel cell CHP from renewable sources may be possible in buildings.

11. BE GREEN – RENEWABLE ENERGY

In this section the viable renewable energy technologies that will reduce the development's CO₂ emissions further by 20% are examined. Incorporating green design measures will significantly reduce the onsite energy consumption and the CO₂ emissions of the building. The 'London Plan' states that a further CO₂ reduction of 20% must be achieved by the installation of renewable technologies. Below is a review of possible renewable technologies for incorporation in the proposed development.

All of the LZC technologies are assessed against a number of criteria. Hence, LZC technology feasibility will be assessed according to the following criteria:

- VI. Renewable energy resource or fuel availability of the LZC technology on the site.
- VII. Space limitations due to building design and urban location of the site.
- VIII. Capital, operating and maintenance cost.
- IX. Planning Permission
- X. Implementation with regards the overall M&E design strategy for building type

The **ADDITIONAL** renewable/LZC technologies which were found non feasible based on the above criteria are the following:

- Wind Turbines
- Biomass Boilers
- Micro CHP
- Hydrogen Fuel Cells
- Small scale hydro power
- Grd. Source Heat Pump (GSHP)

11.1 Wind Turbines

Wind turbines are not feasible for the development since it does not meet the criteria mentioned above. Since the development is located in a dense residential and Offices, Doctor Surgery Unit & Communal Area area; the wind resource may be restricted due to the adjacent large trees and air

turbulence generated between them. The yearly average wind speed is quite low at 10 meters above ground.

Wind speed at 10m above ground level (m/s)

4.9	5.3	5.6
4.8	4.8	5
4.9	4.8	4.9

Wind speed at 25m above ground level (m/s)

5.7	6	6.3
5.6	5.6	5.8
5.7	5.6	5.7

Wind speed at 45m above ground level (m/s)

6.2	6.5	6.7
6.1	6.2	6.3
6.1	6.1	6.2

Squares surrounding the central square correspond to wind speeds for surrounding grid squares.

What does this mean?

Power generated is related to wind-speed by a cubic ratio. That means if you halve the wind-speed, the power goes down by a factor of 8 (which is $2 \times 2 \times 2$). A quarter of the wind-speed gives you a 64^{th} of the power ($4 \times 4 \times 4$).

As a rough guide, if your turbine is rated at producing 1KW at 12m/s then it will produce 125W at 6m/s and 15W at 3m/s.

Please Note!

Syntegra Consulting Ltd, Syntegra House, 63 Milford Road, RG1 8LG T: 08450091625
Registered Company No. 06408056 VAT Registration No. 98001604

E: mail@syntegra-epc.co.uk



Bear in mind that the NOABL wind-speed dataset used here is a model of wind-speeds across the country, assuming **completely flat terrain**. It isn't a database of measured wind-speeds. Other factors such as hills, houses, trees and other obstructions in your vicinity need to be considered as well as they can have a significant effect.

An actual wind-speed measurement using an anemometer has not been used for the purpose of this energy strategy report.

The central square highlighted in yellow demonstrates the average wind speed in m/s for the site. Squares surrounding the central square correspond to wind speeds for surrounding grid squares.

From the above table it is shown that the average wind speed on the development according to **NOABL database was estimated at 4.8m/s at 10m high above ground and 5.6m/s at 25m above ground.**

Wind turbine(s) have been discounted for this development scheme for the following reasons:

- A large mast horizontal axis wind turbine will not be able to generate electricity at optimal operating range since it requires higher average wind speeds. Furthermore, the installation of small scale wind turbines won't be feasible due to low average wind speed at 10 meters height, 25m & 45metre heights.
- Due to the close proximity of neighboring Offices, Doctor Surgery Unit & Communal Area & residential properties and trees.
- In addition, the low frequency noise generated by wind turbines might cause inconvenience to the neighboring residents. However, the level a person can be affected by low frequency noise varies from individual to individual.
- Due to the size and the required height of a potential wind turbine scheme there is also an issue with the propellers' impacting bird traffic, obtrusiveness, shadow flicker which means that generally large wind turbines need to be located at least 300m from any residential properties, which would not be possible on this site.
- Roof mounted units are limited in size due to wind induced stresses which are transmitted to the building structure. Most roof mounted turbines currently on the market are approximately 2m diameter and capable of producing 1-1.5kW each. However, the output is dependent on the surrounding obstructions and local wind speed. Thus small scale wind turbines would not make any meaningful impact on a site such as this.
- There are likely to be planning issues associated with wind turbines of a size necessary to affect any significant CO2 savings or energy savings.
- Because of the above the investment case with regards this technology solution is not viable compared to other solutions with a more attractive ROI.
- Finally, the installation of wind turbines on the development requires planning permission (and is likely to instigate neighborhood committee interest regarding its aesthetics and acoustic issues).

11.2 Biomass Boilers

Biomass boilers should not be considered for this project due to the following reasons:

Syntegra Consulting Ltd, Syntegra House, 63 Milford Road, RG1 8LG T: 08450091625

E: mail@syntegra-epc.co.uk

Registered Company No. 06408056

VAT Registration No. 98001604



- Furthermore, in common with other types of combustion appliances, biomass boilers are potentially a source of air pollution. Pollutants associated with biomass combustion include particulate matter (PM₁₀/ PM_{2.5}) and nitrogen oxides (NO_x) EMISSIONS. These pollution emissions can have an impact on local air quality and affect human health. Biomass has recently been rejected by many London Boroughs as means of obtaining the on-site renewable contribution (and this will soon send ripples out to other regions). This is because of their associated flue emissions (which can be significantly higher than gas fired boilers) and the difficulty of ensuring the boiler will operate at its optimum efficiency, which is often quoted by designers at the initial design stages. Biomass flue emissions are often difficult to control because the quality of fuel can vary significantly between suppliers. Given this a bio fuel system may not be acceptable to the Council on planning grounds (e.g. concerns about associated flue emissions/impact on local 'Air Quality', increase in road traffic from pellet delivery lorries).
- Biomass fuel requires more onerous and frequent wood fuel silo (site storage issues) replenishing by delivery trucks- which in turn can cause site transportation issues that will need to be considered and addressed along with the impact on the other residents and neighborhood infrastructure.
- Restrictions on the type of fuel and appliance may apply to the development and according to studies commissioned by DEFRA the levels of particles emitted by the burning of wood chip or waste would be considered to outweigh the benefits of carbon reduction especially in an urban environment such as the proposed development site.
- Dependant on a fuel supply chain contract being confirmed.
- There is no suitable location for the plant and storage of the pellets on site at present.
- The whole of Camden Council is in a smoke control zone.

11.3 Hydrogen Fuel Cells

Not Offices, Doctor Surgery Unit & Communal Areal viable yet - As a result this solution will not be assessed any further.

The BlueGen product is a ceramic fuel cell and has recently entered the UK market this year.

Using ceramic fuel cells, BlueGen® electrochemically converts natural gas into electricity at up to 60 per cent electrical efficiency. Electricity is consumed locally, with unused power being exported to the grid. When the integrated heat recovery system is connected, the waste heat from BlueGen can be used to produce hot water - which improves the total efficiency to approximately 85 per cent.

11.4 Small scale Hydro

Small scale hydro-electric will not be studied any further because of the location and the spatial limitations of the development. There is no river or lake within the development site boundaries. As a result this solution will not be assessed any further.

Syntegra Consulting Ltd, Syntegra House, 63 Milford Road, RG1 8LG T: 08450091625
Registered Company No. 06408056 VAT Registration No. 98001604

E: mail@syntegra-epc.co.uk



11.5 Ground Source Heat pump (GSHP)

GSHP will not be studied any further for the following reasons:

- If an open loop configuration was to be adopted, a test borehole would be needed to assess the available resource. The test resource process is expensive and of course does not guarantee an acceptable resource in the ground. Additionally, a closed loop borehole configuration could not be used due to spatial limitations of the site.
- There are likely to be planning issues associated with borehole excavation and drilling.
- Running costs and maintenance may be minimal. However, installation is a costly affair. A GSHP solution would represent a relatively expensive option in comparison to other renewable technologies available.
- Additional electric immersion and pumps would be required to heat the GSHP water up to suitable temperature to be used around the building and it's likely a centralised plant area will also be required to house the circulation pumps.
- This technology is not recommended due to the increased plant energy consumption requirements in turn impacting the DER/TER score for the required energy strategy objectives.
- Furthermore, boreholes also destabilize the ground surface and may be considered a minus for environmentally friendly endeavours.

11.6 CHP & Micro CHP

CHP has not been considered further for this project for the following reasons:

- The average maximum heating load of a new apartment (built to 2010 building regs) is approximately 3kW and therefore most individual heating systems with independent condensing gas boilers would be incapable of working at optimal efficiencies or achieving their stated SEDBUK rating due to boiler cycling.
- Traditional CHP should not be considered for this project due to the spatial constraints of the development plot and dwelling layouts. There is not suitable space in the development for CHP plant.
- Heat from the CHP plant could be utilized to drive an absorption chiller during the summer months (tri-generation), but due to the sustainable design of the building fabric, and the use of natural ventilation wherever possible, we anticipate that the cooling load will be minimal, making this a non-viable proposition.
- Micro-CHP is a relatively new concept (Baxi Ecogen was made available in 2009) and issues are raised in relation to unproven technology, inefficiency for shorter run cycles and lack of technical knowledge that can limit the practical application of micro CHP at present. In addition other issues surrounding the fact that around 50% of electricity generated in domestic properties is surplus, high installation costs and estimated low life expectancy has

also been taken into consideration as to its Offices, Doctor Surgery Unit & Communal Area un-viability for this development scheme. Mirco-CHP also has a lower FIT tariff rate and period duration and is only applicable for systems under 2kW

Syntegra Consulting Ltd, Syntegra House, 63 Milford Road, RG1 8LG T: 08450091625
Registered Company No. 06408056 VAT Registration No. 98001604

E: mail@syntegra-epc.co.uk



Regulations Compliance Report

Approved Document L1A 2010 edition assessed by Stroma FSAP 2009 program, Version: 1.5.0.60

Printed on 05 February 2014 at 14:32:23

Project Information:

Assessed By: () **Building Type:** Detached House

Dwelling Details:

NEW DWELLING DESIGN STAGE

Site Reference : 10A Oakhill Avenue **Plot Reference:** House - ashp

Address : 10A Oakhill Avenue, London, NW3 7RE

Client Details:

Name:

Address :

This report covers items included within the SAP calculations.

It is not a complete report of regulations compliance.

1 TER and DER

Fuel for main heating system: Electricity

Fuel factor: 1.47 (electricity)

Target Carbon Dioxide Emission Rate (TER) 21.12 kg/m²

Dwelling Carbon Dioxide Emission Rate (DER) 7.83 kg/m² **OK**

2 Fabric U-values

Element	Average	Highest	
External wall	0.18 (max. 0.30)	0.20 (max. 0.70)	OK
Party wall	0.00 (max. 0.20)	-	OK
Floor	0.15 (max. 0.25)	0.15 (max. 0.70)	OK
Roof	0.12 (max. 0.20)	0.12 (max. 0.35)	OK
Openings	1.40 (max. 2.00)	1.40 (max. 3.30)	OK

3 Air permeability

Air permeability at 50 pascals	4.00	
Maximum	10.0	OK

4 Heating efficiency

Main Heating system:

Heat pumps with radiators or underfloor - electric
Mitsubishi ECODAN 14kW

Secondary heating system: None

5 Cylinder insulation

Hot water Storage: Nominal cylinder loss: 2.43 kWh/day
Permitted by DBSCG: 4.40 kWh/day

Primary pipework insulated: Yes **OK**

6 Controls

Space heating controls Time and temperature zone control **OK**

Hot water controls: Cylinderstat **OK**

Independent timer for DHW **OK**

Yes **OK**

Regulations Compliance Report

7 Low energy lights

Percentage of fixed lights with low-energy fittings	100.0%	
Minimum	75.0%	OK

8 Mechanical ventilation

Continuous supply and extract system		
Specific fan power:	0.76	
Maximum	1.5	OK
MVHR efficiency:	90%	
Minimum	70%	OK

9 Summertime temperature

Overheating risk (Thames valley):	Not significant	OK
-----------------------------------	-----------------	----

Based on:

Overshading:	Average or unknown
Windows facing: North West	20m ² , Overhang twice as wide as window, ratio NaN
Windows facing: North West	31.2m ² , Overhang twice as wide as window, ratio NaN
Windows facing: South East	12.5m ² , Overhang twice as wide as window, ratio NaN
Windows facing: North West	33.8m ² , Overhang twice as wide as window, ratio NaN
Windows facing: South East	14.9m ² , Overhang twice as wide as window, ratio NaN
Windows facing: North West	30.2m ² , Overhang twice as wide as window, ratio NaN
Windows facing: South East	12.9m ² , Overhang twice as wide as window, ratio NaN
Windows facing: North West	20.5m ² , Overhang twice as wide as window, ratio NaN
Roof windows facing: Horizontal	7.87m ²
Ventilation rate:	8.00
Blinds/curtains:	None shutter closed 100% of daylight hours

10 Key features

Thermal bridging	0.04
Air permeability	4.0 m ³ /m ² h
Roof window U-value	1.4 W/m ² K
Windows U-value	1.4 W/m ² K
Doors U-value	1.4 W/m ² K
Roofs U-value	0.12 W/m ² K
External Walls U-value	0.15 W/m ² K
External Walls U-value	0.18 W/m ² K
Floors U-value	0.15 W/m ² K
Floors U-value	0.15 W/m ² K
Photovoltaic array	

Code for Sustainable Homes
Technical Guide November 2010 - Full Technical Guide
Pre-Assessment Report



SYNTEGRA CONSULTING
Intelligent & Green Building Solutions

Report Reference: 14-561
Site Registration: 003939-140205-115-1162
Site Name: 10A Oakhill Avenue
Assessor Number: STRO003939
Company: Syntegra Consulting Ltd
Assessor: Alan King



Site Details

Site Name: 10A Oakhill Avenue
Site Registration: 003939-140205-115-1162
Site Address: 10A Oakhill Avenue

City/Town: London
County: Greater London
Postcode: NW3 7RE
No. of Dwellings: 1
No. of Dwelling Types: 0
Planning Authority: Camden Council
Funding Body:

Assessor Details

Company: Syntegra Consulting Ltd
Assessor Name: Alan King
Cert Number: STRO003939
Address: Syntegra House
63 Milford Road
England
City/Town: Reading
County: Berkshire
Postcode: RG1 8LG
Tel: 08450091625
Email: alan@syntegra-epc.co.uk

Client Details

Company: Eli Nathenson and Julian Bier
Contact Name: Eli Nathenson and Julian Bier
Job Title:
Email:
Tel:
Address:

City/Town:
County:
Postcode:

Architect Details

Company: Martin Evans Architects
Contact Name: Martin Evans Architects
Job Title: Architect
Email: info@martinevansarchitects.com
Tel: 0207 729 2474
Address: 18 Charlotte Road

City/Town: London
County:
Postcode: EC2A 3PB

Developer Details

Company: Eli Nathenson and Julian Bier
Contact Name: Eli Nathenson and Julian Bier
Job Title:
Email:
Tel:
Address:

City/Town:
County:
Postcode:

Dwelling ID	Plot No.	Address	Social Unit
1	1	10A Oakhill Avenue	No

Development Summary & Ratings

Dwelling ID	Dwelling Type	Description	Level	Score
		10A	4	73.45

Deviations from Standard

No deviations from standard

Score Sheet for 10A Oakhill Avenue																																						
Dwelling ID	ENE									WAT		MAT			SUR			WAS			POL		HEA				MAN				ECO					Summary		
	1	2	3	4	5	6	7	8	9	1	2	1	2	3	1	2	1	2	3	1	2	1	2	3	4	1	2	3	4	1	2	3	4	5	Score	Level		
1	6	3	5	3	1	1	2	2	2	2	1	3	0	10	2	1	0	2	4	2	1	1	0	3	4	1	4	3	0	2	2	1	1	1	2	2	73.45	4

Summary Score Sheet

Dwelling Type: 10A

Dwelling ID: 1

			Score Assessment				
	Credit Score	Credits Available	Sub Total	Credits Available	%	Weighting Factor	Points Score
Energy & CO2 Emissions							
ENE 1 Dwelling Emission Rate	6.3	10	22.6	31	72.9	36.4	26.54
ENE 2 Fabric Energy Efficiency	5.3	9					
ENE 3 Energy Display Device	1	2					
ENE 4 Drying Space	1	1					
ENE 5 Energy Labelled White Goods	2	2					
ENE 6 External Lighting	2	2					
ENE 7 Low or Zero Carbon Energy Technologies	2	2					
ENE 8 Cycle Storage	2	2					
ENE 9 Home Office	1	1					
Water							
WAT 1 Internal Water Use	3	5	3	6	50	9	4.5
WAT 2 External Water Use	0	1					
Materials							
MAT 1 Environmental Impact of Materials	10	15	13	24	54.17	7.2	3.9
MAT 2 Responsible Sourcing (Basic Building Elements)	2	6					
MAT 3 Responsible Sourcing (Finishing Elements)	1	3					
Surface Water Run-off							
SUR 1 Management of Surface Water Run-Off from Site	0	2	2	4	50	2.2	1.1
SUR 2 Flood Risk	2	2					
Waste							
WAS 1 Household Waste Storage and Recycling Facilities	4	4	7	8	87.5	6.4	5.6
WAS 2 Construction Site Waste Management	2	3					
WAS 3 Composting	1	1					
Pollution							
POL 1 Global Warming Potential of Insulants	1	1	1	4	25	2.8	0.7
POL 2 NOx Emissions	0	3					
Health & Wellbeing							
HEA 1 Daylighting	3	3	12	12	100	14	14
HEA 2 Sound Insulation	4	4					
HEA 3 Private Space	1	1					
HEA 4 Lifetime Homes	4	4					
Management							
MAN 1 Home User Guide	3	3	7	9	77.78	10	7.78
MAN 2 Considerate Constructors Scheme	0	2					
MAN 3 Construction Site Impacts	2	2					
MAN 4 Security	2	2					
Ecology							
ECO 1 Ecological Value of Site	1	1	7	9	77.78	12	9.33
ECO 2 Ecological Enhancement	1	1					
ECO 3 Protection of Ecological Features	1	1					
ECO 4 Change of Ecological Value of Site	2	4					
ECO 5 Building Footprint	2	2					
			Level Achieved: 4		Total Points Scored: 73.45		

Evidence for ENE 1 (Dwelling Emission Rate)

Improvement above Part L Building Regulations 2010. 6.3 credits allocated

SAP assessments and BRUKL compliance reports show that the building achieves 62.9% improvement over Building Regs. and hence achieves 6.3 credits.

Evidence : SAP assessments and BRUKL compliance reports confirm the assumed number of credits.

Evidence : Architectural drawings

Assumptions for ENE 1

Evidence for ENE 2 (Fabric Energy Efficiency)

Detached

5.3 credits allocated

SAP assessments and BRUKL compliance reports show that the building achieves a FEE of 50.97 and hence achieves 5.3 credits.

Evidence : SAP assessments and BRUKL compliance reports confirm the assumed number of credits.

Evidence : Architectural drawings

Assumptions for ENE 2

Evidence for ENE 3 (Energy Display Device)

Correctly specified display device showing current consumption data.

Assumed a code compliant energy display device will be installed for the current consumption data.

Assumptions for ENE 3

Evidence for ENE 4 (Drying Space)

Compliant external drying space

It has been assumed that code compliant external drying line of 6m+ will be provided in the garden area.

Evidence : Architectural drawings

Assumptions for ENE 4

Evidence for ENE 5 (Energy Labelled White Goods)

A+ rated fridge & freezers or fridge/freezer

A rated washing machine and dishwasher, AND EITHER a tumble dryer (a washer-dryer would be an acceptable alternative to a standalone tumble dryer) with a B rating or where a tumble dryer is not provided, the EU Energy Efficiency Labelling Scheme Information will be provided.

Evidence : It has been assumed that the tenants will be provided with

A+ rated Fridge and Freezers

and

A rated washing machine and dishwasher

and

B rated Tumble dryers

Assumptions for ENE 5

Evidence for ENE 6 (External Lighting)

Complaint space lighting, no security lighting installed

It is anticipated that all communal & external space lighting is provided by dedicated energy efficient fittings with appropriate control systems. An LED lighting and control strategy would assist toward compliance to this credit(s). 100% Low Energy lighting assumed to achieve 45+lumens per circuit watt

It is anticipated that code compliant space and no security lighting is installed.

Assumptions for ENE 6

Evidence for ENE 7 (Low or Zero Carbon Energy Technologies)

Contribution of low or zero carbon technologies greater than or equal to 15%

SAP assessments and BRUKL compliance reports show that the building achieves 23.57% CO2 reduction through renewables and hence achieves 2 credits.

Evidence : SAP assessments and BRUKL compliance reports confirm the assumed number of credits.

Evidence : Architectural drawings (position of PV's to be marked by architect)

Assumptions for ENE 7

Evidence for ENE 8 (Cycle Storage)

4 bedrooms or more - Storage for 4 cycles per dwelling

Evidence: Architectural Drawings

It has been assumed that the cycle storage provided on site will be for a minimum of 4 cycle racks. It is also assumed that it will comply with the following criteria

1. Cycle store to be secured and accessible only to the tenants.
2. Cycle storage to be well lit in accordance with Code requirements.
3. Cycle store to be directly accessible from public way.

Assumptions for ENE 8

Evidence for ENE 9 (Home Office)

Compliant home office

It has been assumed that a code compliant home office location is present. Including a daylight factor of 1.5% (daylight calculation report required for justification). The room requires adequate ventilation (either ventilation system or opening window of a t least 0.5m2), 2No. double power sockets, one telephone point and broadband provision.

It is assumed that the home office location will be located in the lounge area.

Evidence : Floorplans and elevations & specification

Assumptions for ENE 9

Evidence for WAT 1 (Internal Water Use)

Internal water use less than or equal to 105 litres per person per day

It is assumed the minimum code 4 requirement of 105litres/day will be achieved via a correct specification of low flow/flush fittings. Also that the design will be undertaken under risk assessment to avoid microbial contamination for the HWS & CWS systems as per CIBSE guidance

Evidence :Statement of fitting specification(flow rates/capacity), WHB, WC's, Baths, Showers

Code assessors WAT 1 calculation output tool

Assumptions for WAT 1

Evidence for WAT 2 (External Water Use)

Credit not sought or no external rainwater collection system provision

This credit is not sought

Assumptions for WAT 2

Evidence for MAT 1 (Environmental Impact of Materials)

Mandatory requirements met: At least 3 elements rated A+ to D, 10 credits scored

It is assumed that the mandatory requirement will be met in achieving a rating of A+ to D in the 2008 version of the Green Guide for the following elements: Roof, external walls, internal walls (including separating walls), upper and ground floors (including separating floors), windows.

In addition we assume a target of 10 credits will be achieved through correct materials specification accordingly for this category.

Code assessors MAT 1 calculator tool

Assumptions for MAT 1

Evidence for MAT 2 (Responsible Sourcing (Basic Building Elements))

2 credits scored

It has been assumed that building elements will have EMS certification

Assumptions for MAT 2

Evidence for MAT 3 (Responsible Sourcing (Finishing Elements))

1 credit scored

It has been assumed that finishing elements will have EMS certification

Assumptions for MAT 3

Evidence for SUR 1 (Management of Surface Water Run-Off from Site)

Mandatory Met: Peak rate of run-off and annual volume of run-off is no greater for the developed than for the pre-development. The system has also been designed for local drainage system failure.

It has been assumed the mandatory requirements for the code are met

Currently no confirmation is available that there is no change/decrease in impermeable area OR Along with no discharge to watercourse(s) for rainfall depth of upto 5mm and run-off from all hard surfaces receive an appropriate level of treatment (as per SUDS manual). Hence these credits are withheld till further evidence is made available to the assessor.

Evidence : Floorplans and elevations

Assumptions for SUR 1

Evidence for SUR 2 (Flood Risk)

Low flood risk - zone 1

It is assumed the development is in a flood risk 1 zone and the appropriate measures will be incorporated.

Assumptions for SUR 2

Evidence for WAS 1 (Household Waste Storage and Recycling Facilities)

Mandatory requirements met: Adequate storage of household waste with accessibility in line with checklist WAS 1. Local authority collection: Before collection sorting with appropriate internal storage of recyclable materials

It has been assumed that the mandatory household waste storage requirement will be met and that there is a local authority recycling collection scheme (at least fortnightly) where materials are sorted before collection in at least 3No. dedicated internal storage recycling bin. Minimum capacity for the development would be around 600liters +.

It is also assumed that at least 30 litres of internal waste storage (min 7litres per bin) will be provided.

Assumptions for WAS 1

Evidence for WAS 2 (Construction Site Waste Management)

Compliant site waste management plan containing benchmarks, procedures and commitments for the minimizing and diverting 50% waste from landfill in line with the criteria and with Checklist WAS 2a, 2b & 2c

It has been assumed that the appointed contractor will have a code compliant SWMP.

It is also assumed that the contractor will meet the code criteria for the following elements: minimising construction waste, diverting waste from landfill (by at least 50% of weight or volume of non-hazardous construction waste generated of the project being diverted from landfill)

Assumptions for WAS 2

Evidence for WAS 3 (Composting)

Individual composting facility/facilities

Assumed the composting service will be provided for the property.

Assumptions for WAS 3

Evidence for POL 1 (Global Warming Potential of Insulants)

All insulants have a GWP of less than 5

It has been assumed that all insulants specified for the build will have GWP 5 or less.

Assumptions for POL 1

Evidence for POL 2 (NOx Emissions)

Credit(s) not sought

The Energy Strategy report suggests that an ASHP will be provided. Hence no credits can be awarded.

Assumptions for POL 2

Evidence for HEA 1 (Daylighting)

Kitchen: Average daylight factor of at least 2%

Living room: Average daylight factor of at least 1.5%

Dining room: Average daylight factor of at least 1.5%

Home office: Average daylight factor of at least 1.5%

All rooms (kitchen, living, dining and where applicable the home office) have 80% of the working plane with direct light from the sky

It is assumed that all kitchens, living/dining rooms, home office areas achieve a daylight factor of 1.5% and that all rooms (kitchen, living room, and home office) have 80% of the working plane in direct light from the sky.

Daylight calculations will be required to support the above assumption.

Assumptions for HEA 1

Evidence for HEA 2 (Sound Insulation)

Detached property

Since this is a detached property credits are achieved by default.

Assumptions for HEA 2

Evidence for HEA 3 (Private Space)

Individual private space provided.

Evidence: Architectural Drawings

In accordance with the architects drawings, it can be seen that sufficient private space has been provided for the dwelling.

Assumptions for HEA 3

Evidence for HEA 4 (Lifetime Homes)

All criteria of Lifetime Homes in line with all 16 principals of Lifetime Homes

It has been assumed that all 16 criteria of Lifetime Homes will be met.

Evidence: Design and Access Statement

Assumptions for HEA 4

Evidence for MAN 1 (Home User Guide)

All criteria inline with checklist MAN 1 Part 1 - Operational Issues will be met

All criteria inline with checklist MAN 1 Part 2 - Site and Surroundings will be met

It is assumed a code compliant Home User Guide will be produced and made available in the appropriate formats to residents. It is assumed that the Home User Guide meets the criteria for operational issues and site & surrounds.

Assumptions for MAN 1

Evidence for MAN 2 (Considerate Constructors Scheme)

Credits not sought

This credit is not sought

Assumptions for MAN 2

Evidence for MAN 3 (Construction Site Impacts)

Monitor, report and set targets for CO2 production or energy use from site activities

Monitor, report and set targets for water consumption from site activities

Adopt best practise policies in respects to air (dust) pollution from site activities

80% of timber reclaimed, re-used or responsibly sourced

It is assumed that during site works the contractor will, as part of the live SWMP document, monitor/report/set targets for the following:

Adopt best practise policies in respect to air (dust) pollution from site activities

80% of timber reclaimed, re-used or responsibly sourced

energy and water consumption targeted and monitored from site activities.

Assumptions for MAN 3

Evidence for MAN 4 (Security)

Secured by design section 2 compliant

It has been assumed that an ALO/CPDA from the local police force is consulted at the design stage and their recommendations will be incorporated into the design of the development. Also that Section 2 of the Physical security from secured by design -new homes is complied with.

Assumptions for MAN 4

Evidence for ECO 1 (Ecological Value of Site)

Land of low ecological value, achieved through checklist ECO 1. Development site has been identified as low ecological value by a suitably qualified ecologist

It has been assumed that a suitably qualified ecologist will be appointed and will confirm that the land is of low ecological value. Hence one credit can be awarded.

Assumptions for ECO 1

Evidence for ECO 2 (Ecological Enhancement)

Key recommendations and 30% additional recommendations by a suitably qualified ecologist

It has been assumed that a suitably qualified ecologist is appointed and the client undertakes key recommendations outlined by the ecologist along with 30% of additional recommendations, 1 credit can be achieved.

Assumptions for ECO 2

Evidence for ECO 3 (Protection of Ecological Features)

Ecological features will be adequately protected and maintained

It has been assumed that a suitably qualified ecologist is appointed and confirms that the land is of low ecological value and any ecological features are protected and maintained during construction, Hence one credit can be awarded.

Assumptions for ECO 3

Evidence for ECO 4 (Change of Ecological Value of Site)

Neutral: Greater than -3 and less than or equal to +3

It has been assumed that a suitably qualified ecologist is appointed and neutral enhancements are made, 2 credits can be achieved under this category.

Assumptions for ECO 4

Evidence for ECO 5 (Building Footprint)

Housing ratio of 3:1

Basement -2 = 285.4 m²

Basement -1 = 286.3 m²

Lower Gr Floor Area = 211.5 m²

Upper Gr Floor Area = 278.3 m²

1st Floor Area = 273.5 m²

2nd Floor NIA = 169.3 m²

Total NIA = 1504.3 m²

The ratio is calculated as 5.27. Hence 2 credits can be achieved under this category.

Evidence: Architectural drawings

Assumptions for ECO 5

Assessor Declaration

I Alan King, can confirm that I have compiled this report to the best of my ability, I have based all findings on the information that is referenced within this report, and that this report is appropriate for the registered site.

To the best of my knowledge all the information contained within this report is correct and accurate. I have within my possession all the reference material that relates to this report, which is available for inspection by the client, the clients representative or Stroma Certification for Quality Assurance monitoring.

Signed:



Alan King
Syntegra Consulting Ltd
05 February 2014

Information about Code for Sustainable Homes

The Code for Sustainable Homes (the Code) is an environmental assessment method for rating and certifying the performance of new homes. It is a national standard for use in the design and construction of new homes with a view to encouraging continuous improvement in sustainable home building. The Code is based on EcoHomes®.

It was launched in December 2006 with the publication of 'Code for Sustainable Homes: A stepchange in sustainable home building practice' (Communities and Local Government, 2006), and became operational in England from April 2007.

The Code for Sustainable Homes covers nine categories of sustainable design. Each category includes a number of environmental issues. Each issue is a source of impact on the environment which can be assessed against a performance target and awarded one or more credits. Performance targets are more demanding than the minimum standards needed to satisfy Building Regulations or other legislation. They represent good or best practice, are technically feasible, and can be delivered by the building industry. The issues and categories are as follows:

- Energy & CO2 Emissions
 - Dwelling Emission Rate
 - Building Fabric
 - Internal Lighting
 - Drying Space
 - Energy Labelled White Goods
 - External Lighting
 - Low or Zero Carbon Technologies
 - Cycle Storage
 - Home Office
- Water
 - Internal Water Use
 - External Water Use
- Materials
 - Environmental Impact of Materials
 - Responsible Sourcing of Materials - Basic Building Elements
 - Responsible Sourcing of Materials - Finishing Elements
- Surface Water Run-off
 - Management of Surface Water Run-off from the Development
 - Flood Risk
- Waste
 - Storage of Non-Recyclable Waste and Recyclable Household Waste
 - Construction Site Waste Management
 - Composting
- Pollution
 - Global Warming Potential of Insulants
 - NOx Emissions

- Health & Wellbeing
 - Daylighting
 - Sound Insulation
 - Private Space
 - Lifetime Homes
- Management
 - Home User Guide
 - Considerate Constructors Scheme
 - Construction Site Impacts
 - Security
- Ecology
 - Ecological Value of Site
 - Ecological Enhancement
 - Protection of Ecological Features
 - Change in Ecological Value of Site
 - Building Footprint

The Code assigns one or more performance requirements (assessment criteria) to all of the above environmental issues. When each performance requirement is achieved a credit is awarded (with the exception of the four mandatory requirements which have no associated credits). The total number of credits available to a category is the sum of credits available for all the issues within it.

Mandatory minimum performance standards are set for some issues. For four of these, a single mandatory requirement is set which must be met, whatever Code level rating is sought. Credits are not awarded for these issues. Confirmation that the performance requirements are met for all four is a minimum entry requirement for achieving a level 1 rating. The four un-credited issues are:

- Environmental Impacts of Materials
- Management of Surface Water Run-off from Developments
- Storage of Non-Recyclable Waste and Recyclable Household Waste
- Construction Site Waste Management

If the mandatory minimum performance standard is met for the four un-credited issues, four further mandatory issues need to be considered. These are agreed to be such important issues that separate Government policies are being pursued to mitigate their effects. For two of these, credits are awarded for every level of achievement recognised within the Code, and minimum mandatory standards increase with increasing rating levels.

The two issues with increasing mandatory minimum standards are:

- Dwelling Emission Rate
- Indoor Water Use

For one issue a mandatory requirement at Level 5 or 6:

- Fabric Energy Efficiency

The final issue with a mandatory requirement for Level 6 of the Code is:

- Lifetime Homes

Further credits are available on a free-choice or tradable basis from other issues so that the developer may choose how to add performance credits (converted through weighting to percentage points) achieve the rating which they are aiming for.

The environmental impact categories within the Code are not of equal importance. Their relative value is conveyed by applying a consensus-based environmental weighting factor (see details below) to the sum of all the raw credit scores in a category, resulting in a score expressed as percentage points. The points for each category add up to 100.

The weighting factors used in the Code have been derived from extensive studies involving a wide range of stakeholders who were asked to rank (in order of importance) a range of environmental impacts. Stakeholders included international experts and industry representatives.

It is also important to note that achieving a high performance in one category of environmental impact can sometimes result in a lower level of performance for another. For instance, if biomass is used to meet heating demands, credits will be available for performance in respect of energy supplied from a renewable source, but credits cannot be awarded for low NOX emission. It is therefore impossible to achieve a total percentage points score of 100.

The Code uses a rating system of one to six stars. A star is awarded for each level achieved. Where an assessment has taken place by where no rating is achieved, the certificate states that zero stars have been awarded:

Code Levels	Total Points Score (Equal to or Greater Than)
Level 1 ★☆☆☆☆☆	36 Points
Level 2 ★★☆☆☆☆	48 Points
Level 3 ★★★☆☆☆	57 Points
Level 4 ★★★★☆☆	68 Points
Level 5 ★★★★★☆	84 Points
Level 6 ★★★★★★	90 Points

Formal assessment of dwellings using the Code for Sustainable Homes may only be carried out using Certified assessors, who are qualified 'competent persons' for the purpose of carrying out Code assessments.

Energy & CO2 Emissions

ENE 1:Dwelling Emission Rate

Available Credits:10

Aim:To limit CO2 emissions arising from the operation of a dwelling and its services in line with current policy on the future direction of regulations.

ENE 2:Fabric Energy Efficiency

Available Credits:9

Aim:To improve fabric energy efficiency performance thus future-proofing reductions in CO2 for the life of the dwelling.

ENE 3:Energy Display Device

Available Credits:2

Aim:To promote the specification of equipment to display energy consumption data, thus empowering dwelling occupants to reduce energy use.

ENE 4:Drying Space

Available Credits:1

Aim:To promote a reduced energy means of drying clothes.

ENE 5:Energy Labelled White Goods

Available Credits:2

Aim:To promote the provision or purchase of energy efficient white goods, thus reducing the CO2 emissions from appliance use in the dwelling.

ENE 6:External Lighting

Available Credits:2

Aim:To promote the provision of energy efficient external lighting, thus reducing CO2 emissions associated with the dwelling.

ENE 7:Low or Zero Carbon Technologies

Available Credits:2

Aim:To limit CO2 emissions and running costs arising from the operation of a dwelling and its services by encouraging the specification of low and zero carbon energy sources to supply a significant proportion of energy demand.

ENE 8:Cycle Storage

Available Credits:2

Aim:To promote the wider use of bicycles as transport by providing adequate and secure cycle storage facilities, thus reducing the need for short car journeys and the associated CO2 emissions.

ENE 9:Home Office

Available Credits:1

Aim:To promote working from home by providing occupants with the necessary space and services thus reducing the need to commute.

Water

WAT 1:Indoor Water Use

Available Credits:5

Aim:To reduce the consumption of potable water in the home from all sources, including borehole well water, through the use of water efficient fittings, appliances and water recycling systems.

WAT 2:External Water Use

Available Credits:1

Aim:To promote the recycling of rainwater and reduce the amount of mains potable water used for external water uses.

Materials

MAT 1:Environmental Impact of Materials

Available Credits:15

Aim:To specify materials with lower environmental impacts over their life-cycle.

MAT 2:Responsible Sourcing of Materials - Basic Building Elements

Available Credits:6

Aim:To promote the specification of responsibly sourced materials for the basic building elements.

MAT 3:Responsible Sourcing of Materials - Finishing Elements

Available Credits:3

Aim:To promote the specification of responsibly sourced materials for the finishing elements.

Surface Water Run-off

SUR 1:Management of Surface Water Run-off from developments

Available Credits:2

Aim:To design surface water drainage for housing developments which avoid, reduce and delay the discharge of rainfall run-off to watercourses and public sewers using SuDS techniques. This will protect receiving waters from pollution and minimise the risk of flooding and other environmental damage in watercourses.

SUR 2:Flood Risk

Available Credits:2

Aim:To promote housing development in low flood risk areas, or to take measures to reduce the impact of flooding on houses built in areas with a medium or high risk of flooding.

Waste

WAS 1:Storage of non-recyclable waste and recyclable household waste

Available Credits:4

Aim:To promote resource efficiency via the effective and appropriate management of construction site waste.

WAS 2:Construction Site Waste Management

Available Credits:3

Aim:To promote resource efficiency via the effective and appropriate management of construction site waste.

WAS 3:Composting

Available Credits:1

Aim:To promote the provision of compost facilities to reduce the amount of household waste sent to landfill.

Pollution

POL 1:Global Warming Potential of Insulants

Available Credits:1

Aim:To promote the reduction of emissions of gases with high GWP associated with the manufacture, installation, use and disposal of foamed thermal and acoustic insulating materials.

POL 2:NOx Emissions

Available Credits:3

Aim:To promote the reduction of nitrogen oxide (NOX) emissions into the atmosphere.

Health & Wellbeing

HEA 1:Daylighting

Available Credits:3

Aim:To promote good daylighting and thereby improve quality of life and reduce the need for energy to light the home.

HEA 2:Sound Insulation

Available Credits:4

Aim:To promote the provision of improved sound insulation to reduce the likelihood of noise complaints from neighbours.

HEA 3:Private Space

Available Credits:1

Aim:To improve quality of life by promoting the provision of an inclusive outdoor space which is at least partially private.

HEA 4:Lifetime Homes

Available Credits:4

Aim:To encourage the construction of homes that are accessible and easily adaptable to meet the changing needs of current and future occupants.

Management

MAN 1:Home User Guide

Available Credits:3

Aim:To promote the provision of guidance enabling occupants to understand and operate their home efficiently and make the best use of local facilities.

MAN 2:Considerate Constructors Scheme

Available Credits:3

Aim:To promote the environmentally and socially considerate, and accountable management of construction sites.

MAN 3:Construction Site Impacts

Available Credits:2

Aim:To promote construction sites managed in a manner that mitigates environmental impacts.

MAN 4:Security

Available Credits:2

Aim:To promote the design of developments where people feel safe and secure- where crime and disorder, or the fear of crime, does not undermine quality of life or community cohesion.

Ecology

ECO 1:Ecological value of site

Available Credits:1

Aim:To promote development on land that already has a limited value to wildlife, and discourage the development of ecologically valuable sites.

ECO 2:Ecological enhancement

Available Credits:1

Aim:To enhance the ecological value of a site.

ECO 3:Protection of ecological features

Available Credits:1

Aim:To promote the protection of existing ecological features from substantial damage during the clearing of the site and the completion of construction works.

ECO 4:Change in ecological value of site

Available Credits:4

Aim:To minimise reductions and promote an improvement in ecological value.

ECO 5:Building footprint

Available Credits:2

Aim:To promote the most efficient use of a building's footprint by ensuring that land and material use is optimised across the development.

Disclaimer

The contents of this publication reflect the assessment produced by the licensed Code assessor. Stroma Certification Ltd is not liable for any loss or damage sustained as a consequence of this report or any related information.

Copyright

The Code for Sustainable Homes, name, logo and associated documentation are owned by the Department for Communities and Local Government.

All software, calculation tools, templates and all related material provided by Stroma Certification remains the property of Stroma Certification Ltd.