

**GENERAL NOTES**

- This drawing is not to be scaled.
- All dimensions & levels to be checked on site.
- Figured dimensions to be taken on site in preference to scaled dimensions.
- This Drawing is the copyright of the owners.

**KEY**

- SITE BOUNDARY
- EXISTING FABRIC
- PROPOSED NEW WALLS AND SLABS
- STRUCTURES TO BE DEMOLISHED

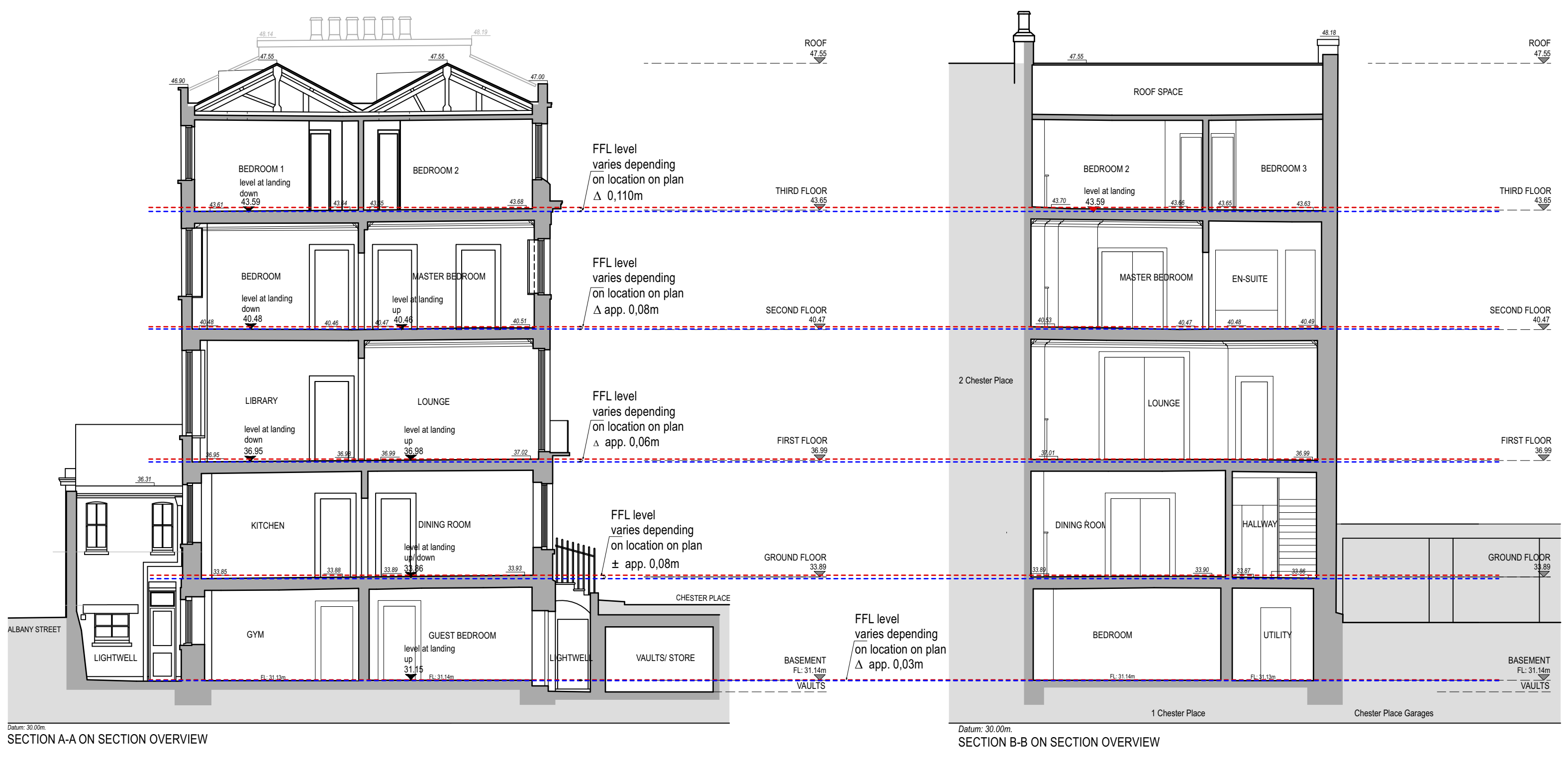

**7 DETAIL SECTIONS FLOOR AS EXISTING**  
1:10

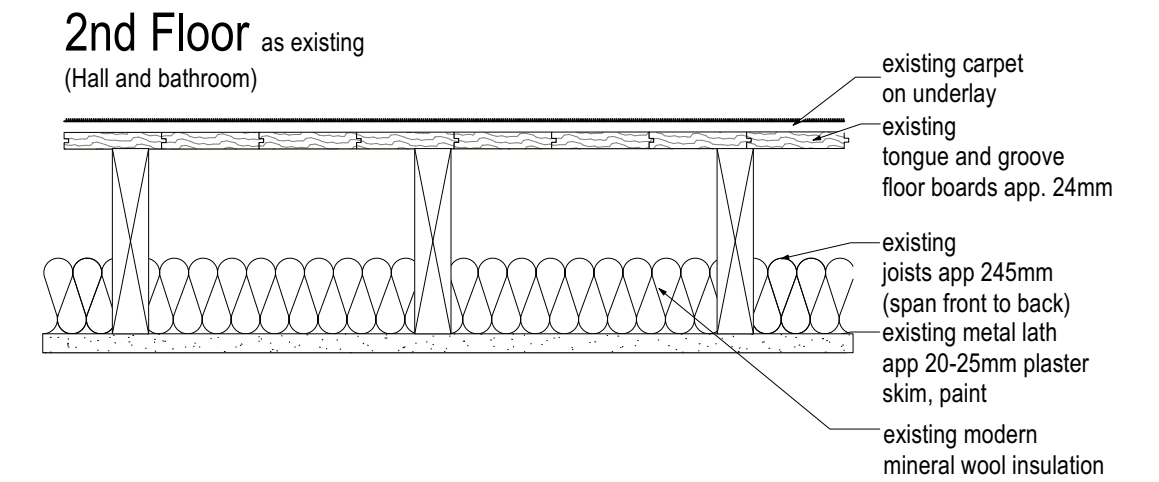
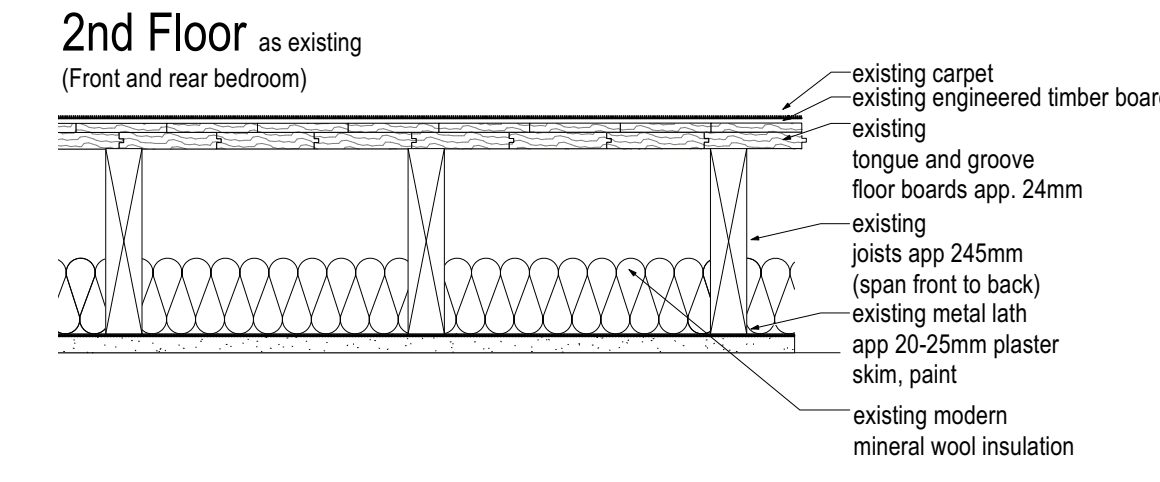
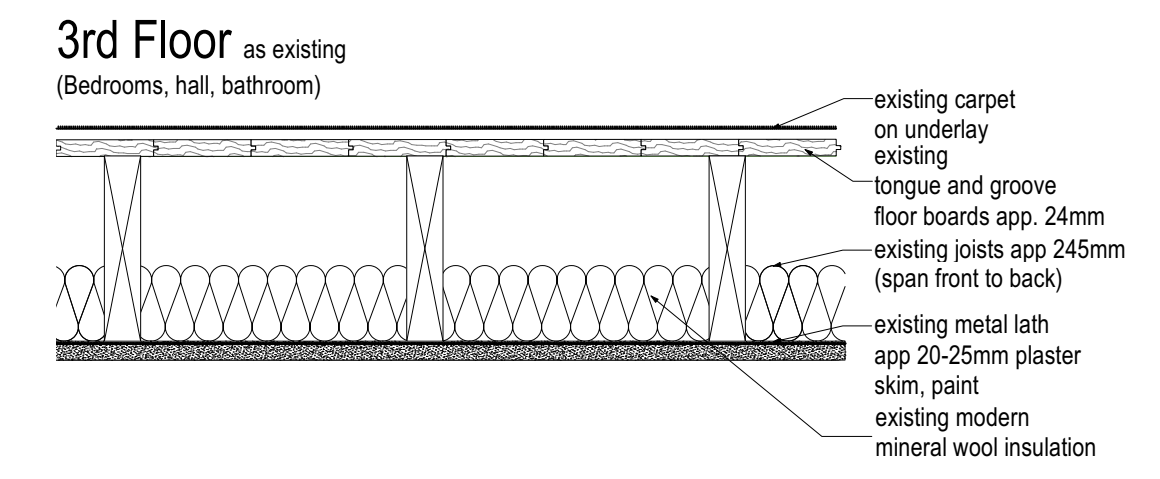

**6 Sections as existing - assessment of floor sagging**  
1:100

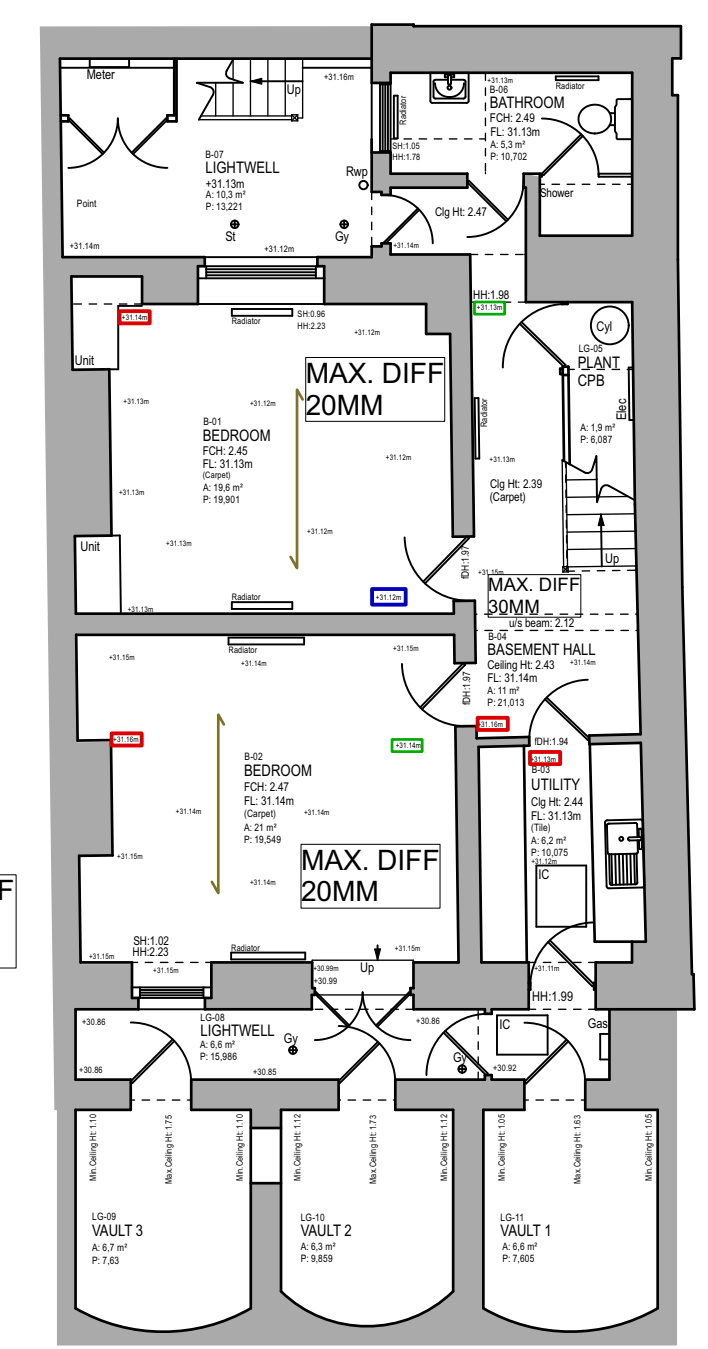

**2 GROUND FLOOR - Existing Floor levels**  
1:100

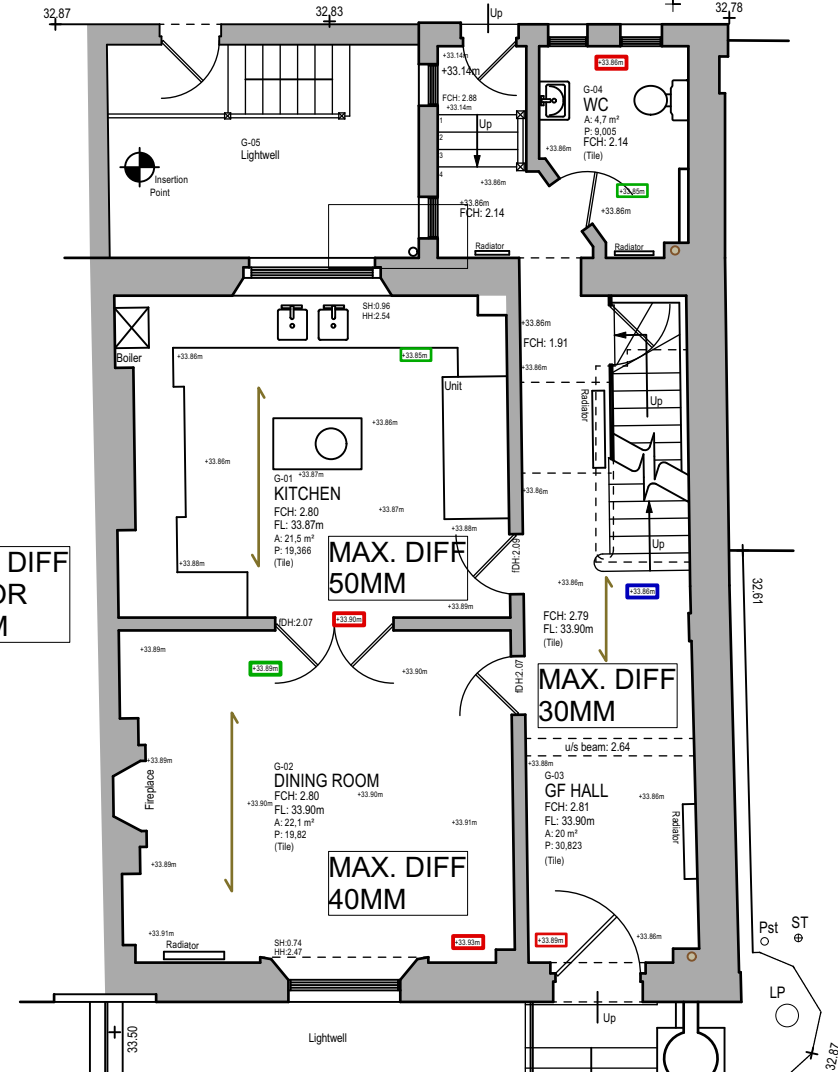

**4 2nd FLOOR - Existing Floor levels**  
1:100

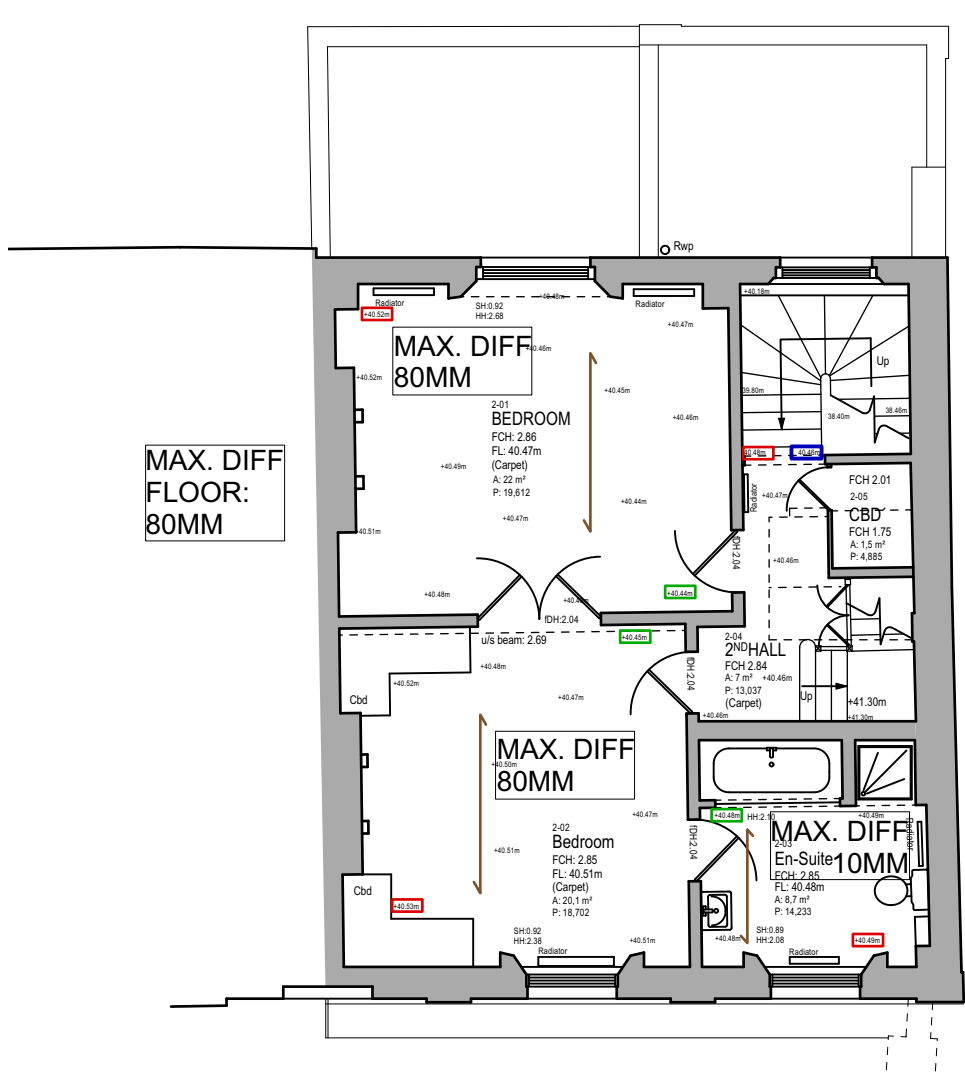

**3 1st FLOOR - Existing Floor levels**  
1:100

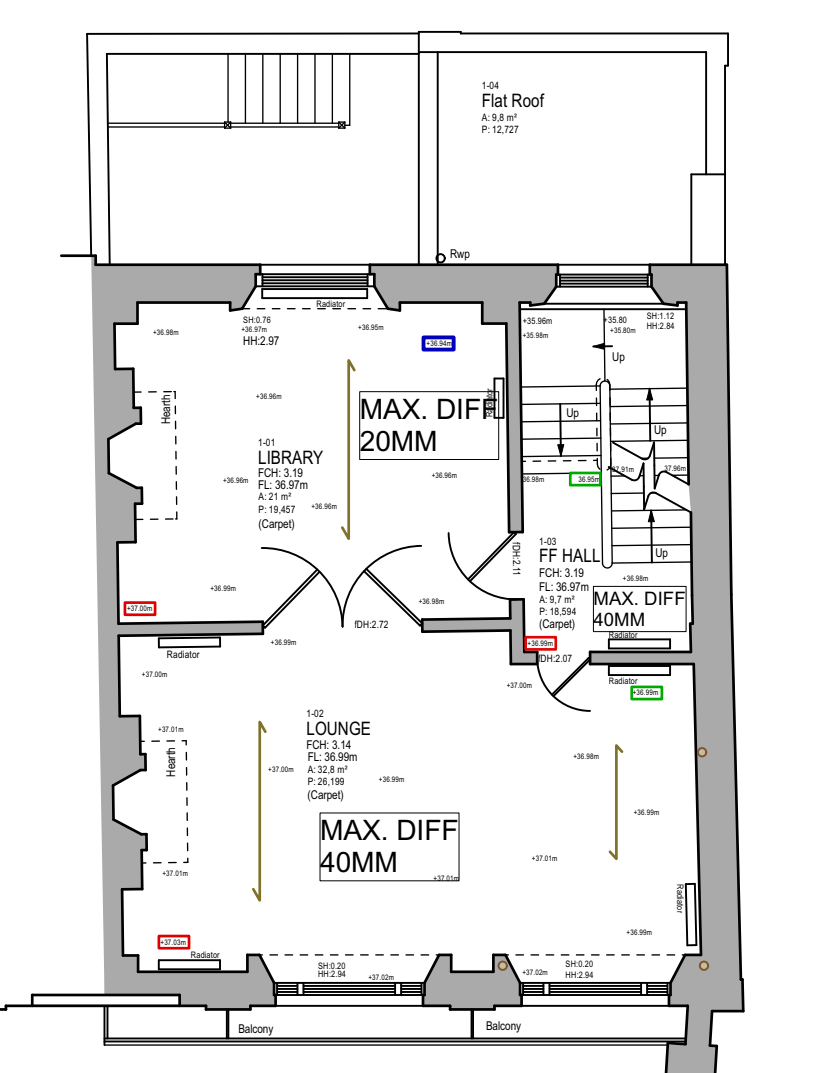

**5 3rd FLOOR - Existing Floor levels**  
1:100

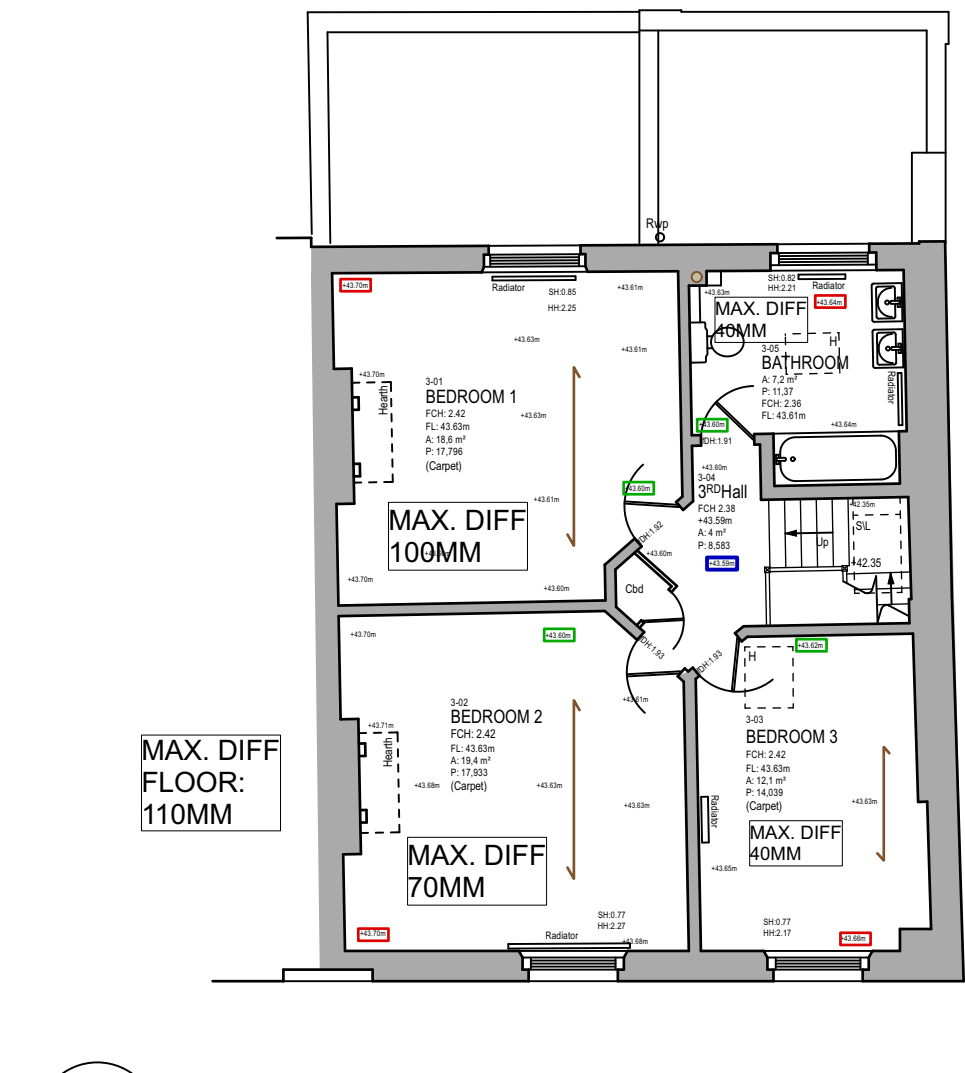

**1 BASEMENT - Existing Floor levels**  
1:100

**LOWEST LEVEL FLOOR**

**LOWEST LEVEL IN ROOM**

**HIGHEST LEVEL IN ROOM**

DIRECTION OF SPAN OF EX. FLOOR JOISTS

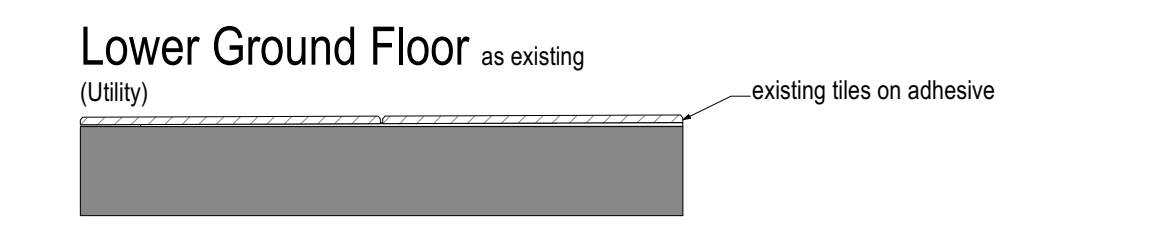
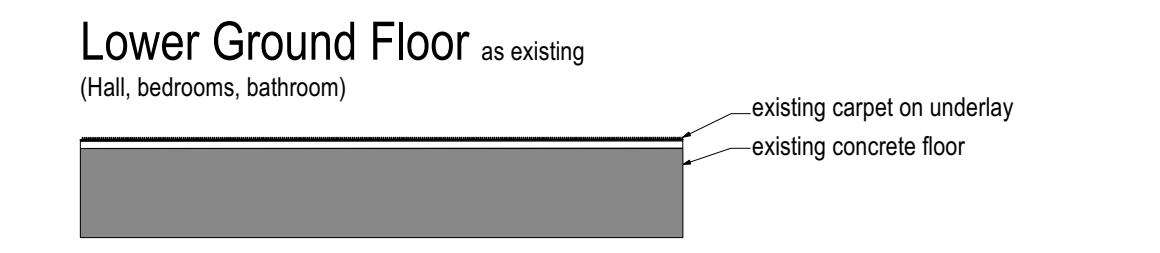
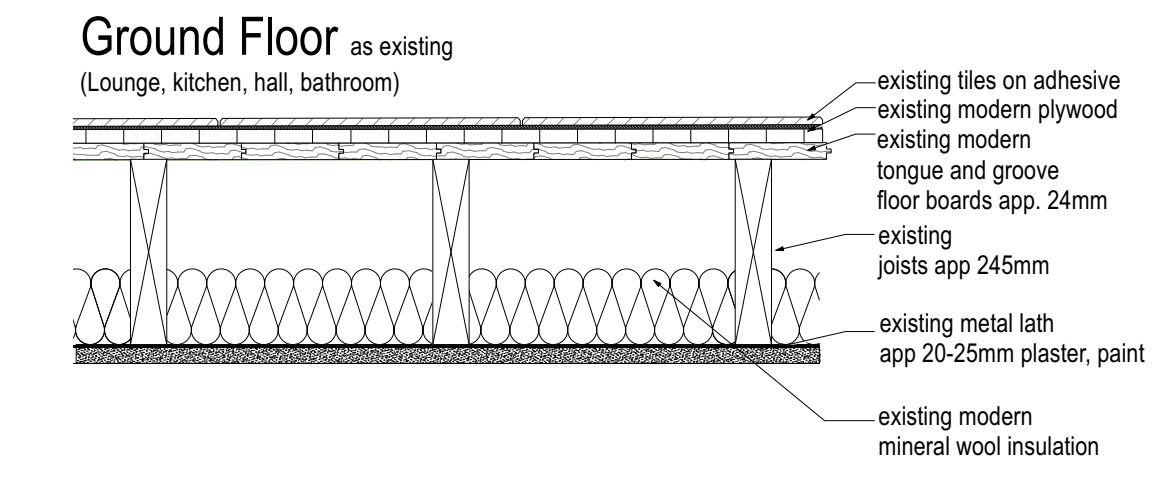
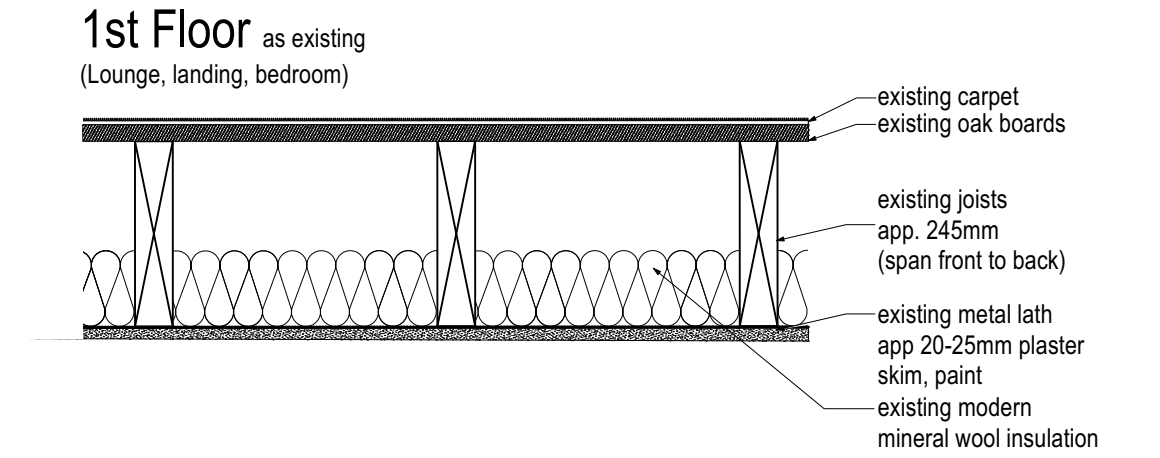

**SURVEY PHOTOS**



**PLANNING APPLICATION AND LBC - AS EXISTING** 2025-02-11

**structureHaus**  
consulting · engineering · designing

LONDON OFFICE 020 8940 7810  
EXETER OFFICE 01392 363497  
info@structurehaus.com  
www.structurehaus.com

PROJECT: REFURBISHMENT OF GRADE 1 LISTED TERRACE  
1 CHESTER PLACE  
LONDON, NW1 4NB

CLIENT: Mr. + Mrs. Davies

SCALE: 1:100 / 1:10

2025-1-1 Chester Place - as existing.rvt

REV	DATE	DETAILS	DRAWN	CHECKED
02962L	4-10			

Drawn by: BM  
Checked by: DP

ISO A1