

Condition 20 pursuant to planning permission ref. 2023/1155/P: Waste & Recycling in relation to 247 Tottenham Ct Rd London W1T 7QZ.

1 Commercial Waste Operations

1.1 WASTE MANAGEMENT STRATEGY

In the absence of any specific waste storage guidance, this assessment has been based on BS5906:2005 Waste Management in Buildings Code of practice.

For office waste, which is calculated based on the number of occupants, an occupation density of 1 person per 10m² NIA has been assumed. BS5906 estimates 50 litres of waste generated per occupant per week.

For F&B retail waste, a volume of 875lt per day per 1000m² NIA is assumed (in line with local guidance).

Using these values and a breakdown by waste stream, as estimated in WRAP (Waste & Resources Action Programme) guidance, the waste storage requirements for each building are given in the tables below.

It is assumed that waste will be scheduled for 2 collection per week, however, to ensure there is sufficient storage should a waste collection be missed, 3 days' worth of waste storage will be provided for all waste streams which equals to 13m³.

Floor	Type	NIA per Floor	Factor	Waste Generation	Waste Rate	Waste Generation / Day (M ³)	Rate
Ground	Café	108	232	0.47	1100	512.1	Daily
Lower Ground	Office	286	929	0.31	1100	338.6	Daily
Ground	Office	271	929	0.29	1100	320.9	Daily
Level 1	Office	1247	929	1.34	1100	1,476.5	Daily
Level 2	Office	1136	929	1.22	1100	1,345.1	Daily
Level 3	Office	1136	929	1.22	1100	1,345.1	Daily

Floor	Type	NIA per Floor	Factor	Waste Generation	Waste Rate	Waste Generation / Day (M ³)	Rate
Level 4	Office	1047	929	1.13	1100	1,239.7	Daily
Level 5	Office	1011	929	1.09	1100	1,197.1	Daily
Lower Ground	Retail	425	232	1.83	1100	2,015.1	Daily
Ground	Retail	624	232	2.69	1100	2,958.6	Daily

Waste Generation Splits (m ³)		
Office	Total	7,263.1
	Residual	1,816
	DMR	5,447
Retail	Total	4,973.7
	Residual	1,243
	DMR	3,730
Café	Total	512.1
	Residual	128
	DMR	96

Bin Calculation				
Storage method	Volume (m ³)	Compaction level	# of units	Units / Wk
Eurobin	1100	0.9	15	7.4

Bin Calculation				
Storage method	Volume (m ³)	Compaction level	# of units	Units / Wk
Eurobin	1100	0.2	0.99	5.0
Eurobin	1100	0.5	0.57	2.8
Wheeled bin	1100	0.2	0.68	3.4
Eurobin	240	0.9	0.48	2.4
Wheeled bin	240	0.2	0.08	0.4

Storage		
Storage method	Area (m ²)	
Eurobin	1.4	26.0
Wheeled bin	1	2
	Total	28.4

The current design offers 12.2m² in the basement and 9.75 m² at ground floor totalling 21.95m².

1.2 OPERATIONAL WASTE STRATEGY

The building manager (BM) will take overall responsibility for the proposed waste management strategy. Specifically, its related responsibilities will include:

- monitoring waste generation, transfer, storage, and coordination of collection daily, and identifying and sorting issues when these arise.
- day-to-day management of waste storage.
- cleaning of any compactors and surrounding surfaces.

- appointing a suitable licensed waste management contractor; and recovery of appropriate costs from tenants through an annual service charge.
- assisting tenants to understand where they can improve on recycling.

1.3 STORAGE AT THE SOURCE

Each tenant will need to provide suitable waste storage areas within their demise which allows their generated waste to be segregated at source into residual refuse, mixed recycling, organic waste, and clinical waste.

If they so wish they can break down mixed recycling, and organic waste further into:

- Paper, Plastics and Cans
- Food
- Coffee
- Glass
- Cardboard
- Coffee Cups
- Compostable/Vegware Stream

1.4 WASTE TRANSPORT

On a daily basis the tenants will transport the days waste to the basement store and place within the bins provided.

Twice per week, the sites FM team will move the full bins to the ground floor in readiness for the removal from site by the employed waste contractor.

The waste contract will park outside of the building's entry point on Morwell Street and using the buildings intercom will contact the sites security team, who will then make contact with the sites cleaning operatives who will assist the waste company with the movement of bins from the ground floor to the vehicle and then return the bins to the basement.

Note:

- A dropped kerb exists along Morwell Street that will be shared with the 1 Bedford gardens



Incoming waste transport



Out-going Transport

1.4.1 CAFÉ Waste Removal

Due to the isolation of the CAFÉ unit, where no internal access has been designed, the CAFÉ unit will require to use off street waste removal.

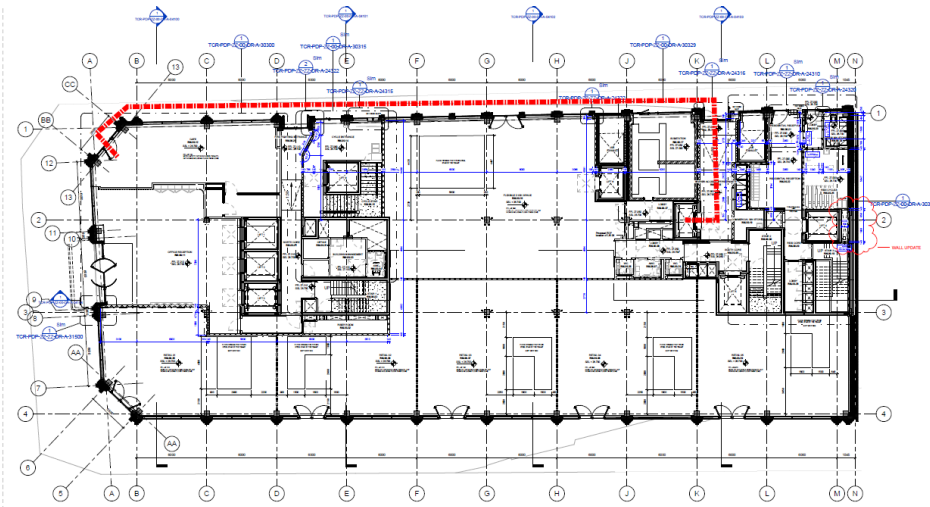

We have indicated the route that the CAFÉ operator would be required to move waste, as this impacts the public pavement, we suggest that a more local off-street arrangement is used. This can be arranged either with the LBC or with agreement via the commercial operator.

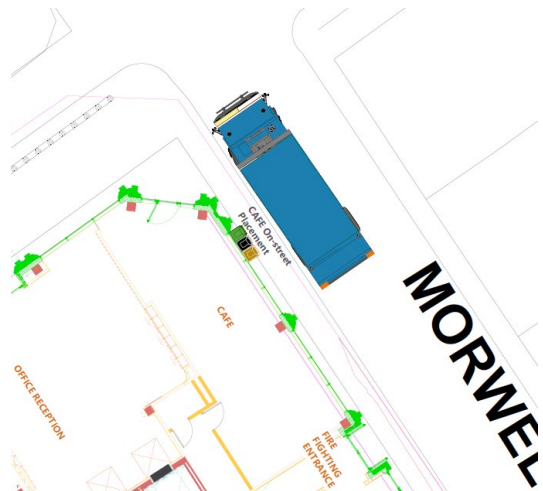

The CAFÉ unit will be designed under CAT B to have an internal waste storage area large enough to store 48 hours' worth of waste, the operator will arrange waste removal to suit their requirements, but as a minimum removal every other day of operation. Waste will be placed as shown on the pavement up to an hour before lifting, and the bins will then be brought into the unit following removal.

1.4.2 Retail Unit 4 Waste Removal

It has been agreed that retail unit 4 can be serviced from the street



As with the CAFÉ unit, Retail Unit 4 is isolated from accessing the internal waste room, permission has been granted to allow this unit to service from the street.

The retailer will engage with a waste removal company and will arrange for timed off street collections of all required waste streams.

The retail unit will be designed under CAT B to have an internal waste storage area large enough to store 48 hours' worth of waste, the operator will arrange waste removal to suit their requirements, but as a minimum removal every other day of operation. Waste will be placed as shown on the pavement up to an hour before lifting, and the bins will then be brought into the unit following removal.

2 General Policy

The managing agent should work towards ISO14001 accreditation over the course of the first 48 months of operation. The intention is to promote a zero-waste solution wherever possible or utilise methods to minimise the waste going into land fill.

Each Tenant will be encouraged to introduce a bespoke waste minimisation and recycling scheme with the aim of zero refuse reaching landfill, this will mean that all tenants will need to review their management during the fit-out design stage so that they align with the requirements across the building.

The building manager will be operating a refuse recycling scheme for the benefit of all tenants with the aim of recycling 100% of the building's waste products where possible across the standard waste streams.

- The waste strategy will focus on separation at source of the following materials:
- Paper, Plastics and Cans*
- Food
- Coffee
- Glass
- Cardboard
- Coffee Cups
- Compostable/Vegware Stream
- General Waste (Incineration) Batteries

- WEEE (Waste Electrical and Electronic Equipment)



The stages are:

PREVENTION - using less material in design and manufacture. Keeping products for longer; re-use. Using less hazardous materials.

PREPARING FOR RE-USE - Checking, cleaning, repairing, refurbishing, whole or spare parts.

RECYCLING - Turning waste into a new substance or product. Includes composting if it meets quality protocols.

OTHER RECOVERY - Includes anaerobic digestion, incineration with energy recovery, gasification and pyrolysis which produce energy (fuels, heat, and power) and materials from waste, some backfilling.

DISPOSAL - Landfill and incineration without energy recovery

Tenants are required to ensure that their layout design incorporates adequate space for the installation of on-floor and back of house waste receptacles for these waste elements. We would ask that all tenants think about the design of their fit outs to meet the requirements of the long-term goals.

The Landlord provides main waste containers, as appropriate in the waste area for the building.

2.1 SIGNAGE

It is often challenging for businesses to generate buy-in and broad participation in recycling initiatives within their facilities. There are many ways to reinforce the process and educate your employees, but without a doubt, the best place to start in order to make significant positive improvements is by incorporating signage on your waste & recycling receptacles.

Within the main bin storage area signage will be installed to assist users understand what they can and more importantly cannot place inside the bins, examples are below:

2.1.1 Contaminated Recycling or Food Waste

The site cleaning team will monitor all waste within the commercial storeroom and where contamination has been found, they will report this to the tenant's manager who will be asked to ensure their staff understand the waste streams. The Building Manager will also run training and understanding sessions for the tenant if required.

Where contamination has been found, this will be resorted where possible and placed within the correct bins. Where this is not achievable, waste will be removed into the general waste bin.



2.2 BIN PROVISION:

11 no bins will be stored in the basement waste room.

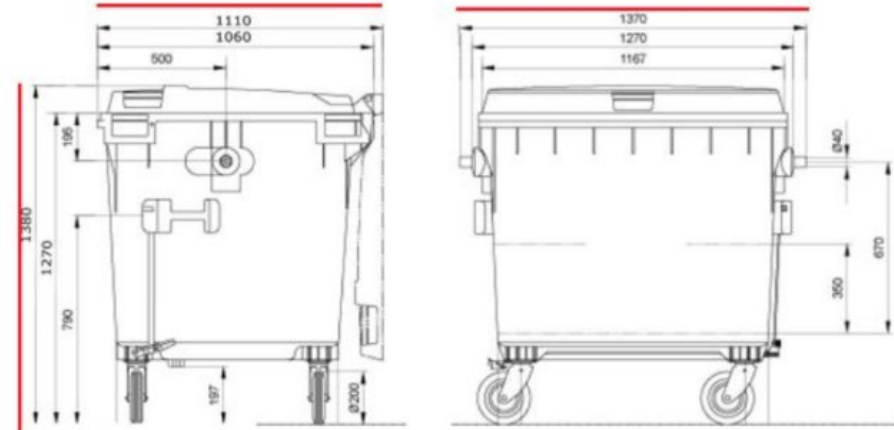

GENERAL WASTE:

(2 1100 ltr eurobins) Black Bin: General waste

RECYCLING:

(3 1100 ltr eurobins, 2 240 ltr glass, 2 240 ltr general organics and 2 240 ltr coffee grids)

Green Bin: Recycling

Plastic- including bottles, pots, tubs, cartons, and carrier bags (empty and untied), aluminum foil and bottle tops, tins, cans, and aerosols.

BLUE BIN: RECYCLE

PAPER - including newspapers, magazines, and letters
Cardboard - including cereal and egg boxes.

Confidential Paper Waste

Each tenant would normally arrange any confidential paper waste removal, and the bins would be located within the demised. The tenant would then arrange either an exchange or shred on site depending on their own security arrangement. On the day of collection, the supplier will follow the same route along Bedford Court Mansions/Bedford Avenue turning into Morwell Street. They will park outside of the commercial entrance and use the intercom to notify the site team of their attendance.

The cleaning team will then bring the bins out onto the street.

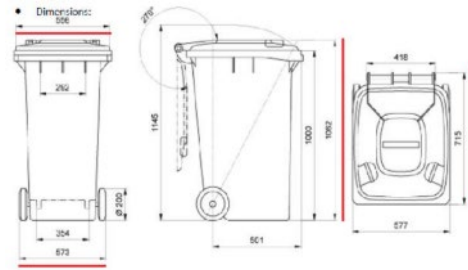

FOOD WASTE: (2 240 ltr wheelie bin)

Brown Bin, Food waste.

Fruit, vegetables, meat, fish, bones, tea bags, bread, pastries, dairy products, rice, pasta, beans, eggs, eggshells, cooked food, leftover food & other general Food Waste

FOOD WASTE: (2 240 ltr wheelie bin)

Red Bin, Food waste.

Coffee grounds

2.3 COLLECTION:

The bins will be taken from the basement waste room and held on the ground floor, the waste service partner will then exchange the bins or empty them and return them to the holding area at ground floor. The cleaning team will then take the bins back to the basement waste room.

The number of lifts per week will meet the demands of the tenant base, as a guide this would be point every Tuesday and Thursday morning ready for collection.

2.4 Bin Movement

Each of the commercial tenants will bring their waste from their demise and place it to the bins provided within the main store at basement 1.

On the day of collection, the commercial waste company contractor will follow the route along Bedford Court Mansions/Bedford Avenue turning into Morwell Street. They will park outside of 1 Bedford Avenue Loading Bay and use the intercom to notify the site team of their attendance.

The cleaning team will then bring the bins out onto the street, where the waste company will take the bins along the pavement and into the back of their vehicle for emptying, once finished the contractor will return them to the commercial doorway and the internal



cleaning staff will replace them back in the bin store, by doing this, no bins will be left on the street.



2.4.1 Basement Store

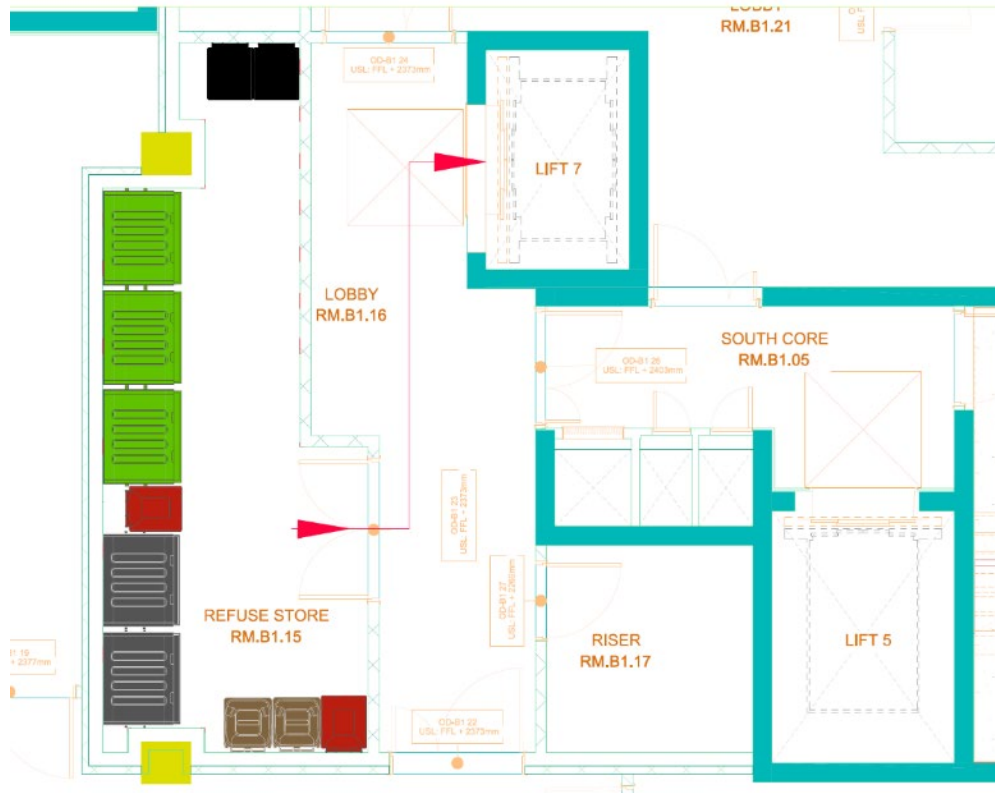

All rooms will be built to meet BS5906.

2.4.2 Ground Floor

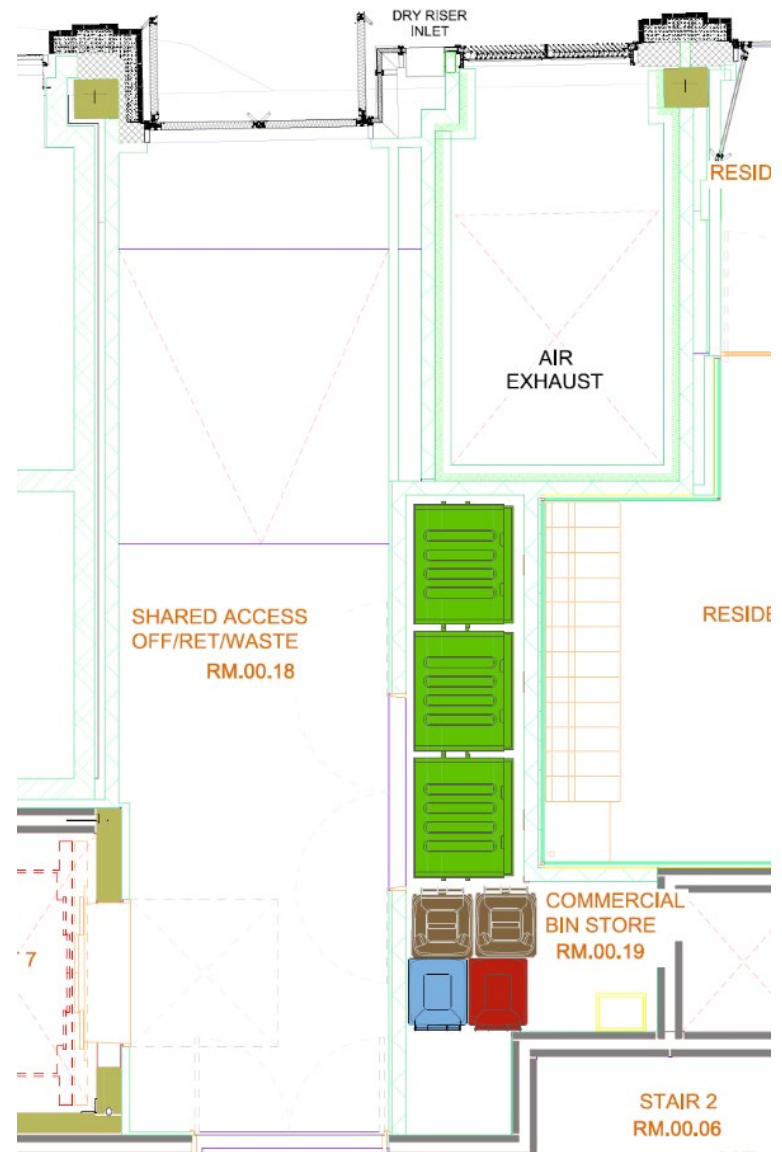

3 Residential

Residential waste arisings have been calculated in accordance with LBC guidance using the communal collection method. Communal collections need to look at the systems for temporary waste storage, handling, on-site treatment, and collection. The property has included a dedicated residential waste room at ground floor. This means that no bins will be placed onto the pavement for prolonged period, the sites cleaning team will be on hand to assist the LBC contractor with the removal and replacement of all bins.

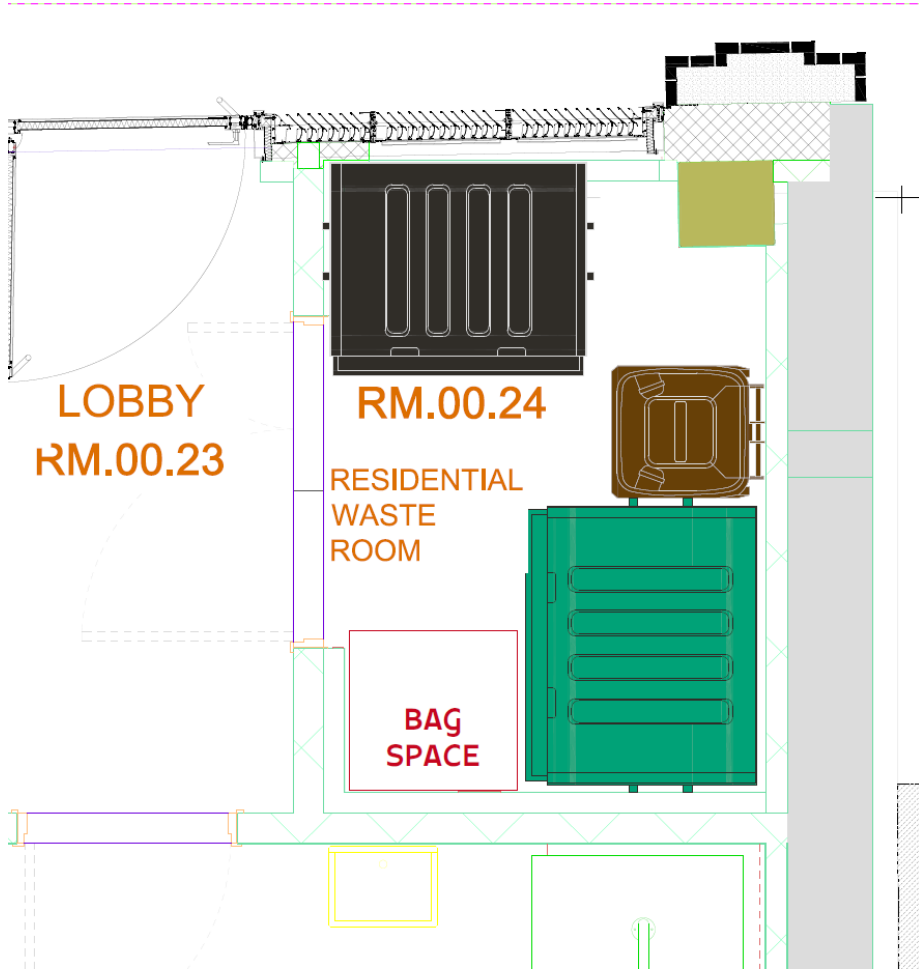

It has been assumed that all bins are full at the time of collection to provide a worst-case scenario.

3.1 RESIDENTIAL DEVELOPMENT - COMMUNAL COLLECTION

This generally includes estate complexes, developments, cul-de-sacs, mixed-use developments, housing blocks, extensions to existing housing complexes.

Collection services for developments with multiple residential dwellings may vary depending on the individual circumstances of the premises. It is worth calculating the arrangements per building 'shell' or units associated with each shared bin storage point.

Communal collections need to look at the systems for temporary waste storage, handling, on-site treatment, and collection. Refer to section 12. Temporary storage, storage chambers and wastes transfer. This should be built in accordance with British Standard BS5906-2005, in particular sections 4, 6, 7, 8, 9 and 10.

- General principles of design facilities (4)
- Systems of waste storage, handling, on site treatment and collection (6)
- Choice of method of storage and collection of waste in various types of building (7)
- Waste storage containers (8)
- Storage for bulky articles (9)
- Roads and approaches to buildings (10)

Where communal facilities are required for each waste storage point the following approximate conversions would apply:

3.2 WEEKLY CONVERSION RECYCLING ONLY

100% participation	Mixed recycling bin	Food waste bin	Textiles floor area/cage
7+ flats	No. of dwellings x 140L bin Size 1280L / 1100L / 660L	No. of dwellings x 23L caddy Size 1 x 240L	7+ 55L sacks+ 7+ 25L sacks+

100% participation	Mixed recycling bin	Food waste bin	Textiles floor area/cage
10 flats	1 x 1280L / 2 x 660L / 1 x 1100L	1 x 240L	Area Size 1M ³

for calculating spatial dimensions for container footprint

3.3 WEEKLY GENERAL WASTE AND REUSE

Participation	Refuse	Bulky Waste /Reuse	WEEE (Small / Large Electrical)
7+ flats	No. of dwellings x 120L Size 1280L/ 1100L / 660L	No. of dwellings x Minimum 3M ³ area	7+ 55L sack 1M ³
10 flats	1 x 1280L / 2 x 660L/ 1 x 1100L	3M ³	1M ³

3.4 APARTMENTS

The property has 9 apartments over 5 floors, with apartments.

Apartment	Number	Beds	NIA (M ²)
Level 1	Flat 1	2	107
Level 2	Flat 2	2	107
Level 2	Flat 3	3	100
Level 3	Flat 4	2	107
Level 3	Flat 5	2	99
Level 4	Flat 6	2	84
Level 4	Flat 7	2	80
Level 5	Flat 8	4	88
Total		19	772

Using the above tables.

3.5 WASTE TOTALS

	Waste Generation per flat	No. Flats	Total Waste Ltr
Refuse	120	8	960
Mixed recycling bin	140	8	1120
Food waste bin	23	8	184
Textiles floor area/cage	55	8	440

3.6 BIN REQUIREMENTS

	Total Waste Ltr	Bin Size	No. Bins
Refuse	960	1100	1
Mixed recycling bin	1120	1100	1
Food waste bin	184	240	1
Textiles floor area/cage	440	55	8

3.7 NON-HAZ HOUSEHOLD WASTE ANCILLARY ITEMS

Where a tenant has generated waste of a non-Haz household type (Batteries, WEEE, Paints and Chemical liquids, Vapes, Textiles, lighting non-LED, Nappies), these will be removed via one of the following methods.

3.7.1 Batteries, WEEE, Vapes and Lighting non-LED.

Local recycling centres

Little Waitrose & Partners (246 High Holborn, London WC1V 7EX) offers a small item recycling service, this includes:

You can bring your old electrical items to be recycled at any Waitrose & Partners shop.

The item you want to return and recycle doesn't need to have been bought from us (either online or in store).

If your item is very small, and less than 25cm on its longest side, then you can take it to one of our branches whenever you wish.

If your item is larger than 25cm on its longest side, we will currently accept a like-for-like equivalent when you are purchasing a new item.

Please make sure the item you're returning is clean and dry, and that any personal data has been removed from its memory - follow the instructions on the device to restore to factory settings or follow this handy guide supplied by www.recyleyourelectricals.org.uk.

If you're not sure how to remove your personal data, we offer an in-store service where our specialist Partners will clear all data from your old device. There's a small fee for this service.

Please take your old item to either the Customer Collection Point or the Tech Support Desk in store for recycling.

All other items will be taken to Regis Road Reuse and Recycling Centre.

Regis Road Recycling Centre, Kentish Town, London, NW5 3EW

3.7.2 Nappies

Nappies are made from a combination of natural and synthetic materials. For this reason and for hygiene reasons, they cannot be recycled and should go in the general waste (not flushed down the toilet).

3.7.3 Paints and Chemical liquids (outside of general domestic cleaning chemicals)

Paint and varnish that could be reused can be taken to any of north London's reuse and recycling centres, but not Hornsey Street (Islington), Gateway Road (Waltham Forest), Barrowell Green (Enfield). This scheme is part of the Community Repaint (opens in new window) reuse scheme. The leftover paint/varnish is also available for residents to take away for free from these sites.

If product is too old to be reused, there are various ways to dispose of it:

3.7.3.1 WATER-BASED PAINT (EMULSION)

Take it to any of our north London reuse and recycling centres (RRC) apart from Hornsey Street (Islington) and Barrowell Green (Enfield).

If you fully dry it out, the emulsion can be disposed of in your normal rubbish bin. To dry the paint, take the lid off, add some sand or sawdust and then leave for several weeks.

3.7.3.2 OIL-BASED PAINT (GLOSS) OR VARNISH

Oil-based paint is 'hazardous' and should never be put in the rubbish bin. You can book a hazardous waste collection with the City of London Hazardous Waste Service (opens in new window). This is free for all north London residents.

3.8 BULKY WASTE

As the residential units are short term leased units, the apartments are fully fitted out by the landlord and all services (apart from utilities) will be managed directly by the landlord. This means that the landlord will be responsible for the removal of any and all bulky waste items. The Landlord will arrange this via private contractor who will remove the item from the apartment straight into a waiting vehicle. This method removes the requirements for on-site storage.

3.8.1 Large item collections

You can arrange collections for large items with Veolia.

For example:

- beds or mattresses
- broken furniture
- extra bags of rubbish

3.8.1.1 HOW MUCH DOES IT COST?

It costs:

- £25 for 1 to 5 items, or up to 20 black bags
- £50 for 6 to 10 items, or up to 40 black bags
- £75 for 11 to 15 items, or up to 60 black bags
- Large electrical items are charged separately. It is £10 for up to 2 Large electrical items.

You may be eligible for 2 free collections each year, if you are a Camden resident and:

- are aged over 65.
- receive 100% Council Tax Support

3.8.2 How to book a collection

Collections can be booked through Veolia.

You will need to provide:

- the address of the collection
- details of what needs collecting.

3.8.3 Veolia will only be able to collect items:

from outside your home at street level during the week between Monday and Friday

If a resident requires help putting your large items outside of the property they should, contact Camden's handyperson service.

To arrange a large item collection, call Veolia on 020 3567 8105

3.9 SIGNAGE

It is often challenging for residents to fully understand what they can and cannot place into the council supplied bins, signage posters and bin signage will be installed to the storage location to assist each of the resident understand the dos and don'ts.

The building management team will liaise with the local council to ensure that the correct signage is placed and will assist the resident by offering them a guideline within the residential rules.

3.9.1 Contaminated Recycling or Food Waste

The site cleaning team will monitor all waste within the residential storeroom and where contamination has been found, they will report this to the residential manager who in turn will send additional information to each of the residents explaining what should be entered into each of the waste stream.

Where contamination has been found, this will be resorted where possible and placed within the correct bins. Where this is not achievable, waste will be removed into the general waste bin.

Recycling bin

Please rinse items before recycling to prevent contamination of other materials. Please put items in loose (not in bags)

Paper: Newspapers, magazines, printer paper, junk mail, shredded paper, envelopes (including windows), wrapping paper and greeting cards (without glitter or embellishments).

Food and drink cartons: eg. Tetra Paks

Chocolate/Biscuit tins/trays/tubs

Cardboard: Toilet roll centres, plain greeting cards, corrugated card, cardboard boxes, sleeves and tubes.

Plastic pots/tubs/trays

Glass bottles/jars: Any colour.
No drinking glasses or glass kitchenwear.

Plastic Bottles: Drinks, toiletry bottles, and cleaning/detergent bottles.

Aluminium foil/foil trays (clean only)

Drink cans and food tins

Aerosol cans: (empty)

Please do not place the following items in your recycling bin:
Textiles, nappies, paint tins, food waste, polystyrene, rigid plastics (toys), garden waste, electrical items, plastic bags/film, padded envelopes, paper towels/tissues, cotton wool/wet wipes, general household waste, plastic pouches, biodegradable packaging, cookware, kitchenware, ceramics, glass kitchenware/drinking glasses.

Food pod

All food waste out of any packaging

Tea Bags
Raw/cooked meat
Plate scrapings
Bones
Peelings
Egg shells
Out of date food

Please do not place garden waste or biodegradable packaging (other than liners) in your food pod.

Refuse bin

ONLY waste that cannot be recycled, reused or composted

Please do not place textiles, batteries, electrical items, food waste, recyclables or garden waste in your refuse bin

Garden waste bin

Fallen leaves
Dead plants
Grass cuttings
Wood prunings

Please do not place biodegradable packaging, garden toys, plant pots, soil or treated wood in your garden waste bin

3.10 Bin Movement

Each of the residents will bring their waste from their apartment local store and place it to the bins provided within the main store at ground floor.

On the day of collection, the LBC contractor will follow the same route along Bedford Court Mansions/Bedford Avenue turning into Morwell Street. They will park outside of 1 Bedford Avenue Loading Bay and use the intercom to notify the site team of their attendance.

The cleaning team will then bring the bins out onto the street, where the waste company will take the bins along the pavement and into the back of their vehicle for emptying, once finished the LBC contract will return them to the residential doorway and the internal cleaning staff will replace them back in the bin store.

