

Planning, Design and Access Statement

In support of a planning application for the installation of a Santander Cycle docking station and terminal on:

the carriageway adjacent to Truro House, Mount Pleasant, WC1X 0AE in the London Borough of Camden.

Date: February 2025



Contents

| | | | |
|--|-----------|--|-----------|
| Executive Summary | 3 | | |
| Part 1 Design Statement | 4 | Part 4 Site and Proposal | 18 |
| 1.1 Overview Cycle Hire Scheme | 4 - 7 | 4.1 Surrounding Environment, Site Characteristics & Proposal | 18 |
| 1.2 Site selection Criteria | 8 - 11 | 4.2 Key Considerations and Assessment | 19 |
| Part 2 Access Statement | 12 | | |
| 2.1 Inclusive Access | 12 | | |
| 2.2 Pedestrian Circulation | 13 | Part 5 Implementation, Operation and Maintenance | 21 |
| Part 3 Planning Policy and Guidance | 14 | 5.1 Implementation | 21 |
| 3.1 Introduction | 14 | 5.2 Maintenance and redistribution | 21 |
| 3.2 The Development Planning Framework | 15 | 5.3 Operation | 22 |
| 3.3 Other Material Considerations | 16 - 17 | Part 6 Application Summary | 23 |
| 3.4 Streetscape Design guidance | 17 | | |

Executive Summary

Transport for London (TfL) has been providing the cycle hire scheme to London for over 10 years on behalf of the Mayor. This has proven a very successful scheme since its launch with numerous expansions and continued popularity among Londoner’s and tourists alike. Cycle hire was launched by the Mayor in July 2010 and to date more than 99 million journeys have been made. The scheme was first introduced to achieve and promote a safe and convenient public access to cycle for short trips, especially for those who do not usually cycle or own a bike. The scheme was implemented to achieve the Mayor’s key goals at the time of low emission transport, and it has adapted to now meet the Healthy Streets and Active Travel objectives set out by the Mayor in the London Plan 2021 and Mayors Transport Strategy 2018. To date, cycle hire has played an important role with leisure cycling amidst the COVID-19 pandemic, and the move towards making use of active modes of transport to complete journeys.

The Healthy Streets Approach aims to deliver patterns of land use which facilitate residents to make shorter, more regular trips by walking and cycling. Cycle hire meets the aims set out by this vision and the indicators.

The Cycle Hire Scheme:

- Improves general health through providing an attractive, viable and active travel option;
- Reduces health inequalities by providing access to a bike at an affordable rate;
- Provides a viable alternative to car use helping to provide quicker and more sustainable commuting options; and
- Adds to the street scene and public realm providing a convenient and accessible mode of transport

Active Travel is also another important part of the Healthy Streets initiative with the central aim being for every Londoner to have 20 minutes of active travel a day. This is mostly achieved through commuting hence cycle hire plays an important role by providing a cost-effective, sustainable and accessible way for people to meet this target. Docking stations are conveniently located both in local residential areas and places of work. Following the recent intensification of expansion on the existing cycle hire network there are now more than 12,000 bicycles at over 21,000 individual docking points operating from approximately 800 stations.

This Statement incorporates an appraisal of relevant planning policy, considers design and access, as well as how this application will be implemented and operated. It demonstrates how TfL, along with its partners, has had special regard for the design at a variety of locations across London. This Statement is provided in support of a full planning application for the installation of a standard docking station on the carriageway adjacent to Truro House, Mount Pleasant, WC1X 0AE. This application follows consultation with the London Borough of Camden, who secured funding towards a new Santander cycle hire docking station from the Postmark development (land west of the Royal Mail sorting Office at Mount Pleasant).

This Statement concludes that the proposal is supported by, and is consistent with, the relevant planning policy and guidance within national and local development plans and strategies. The docking station will be appropriate within the existing local environment and as part of the wider cycle hire scheme will contribute to an innovative and sustainable transport system in London.



Part I Design Statement

1.1 Overview of Cycle Hire Scheme

TfL continues to actively manage existing docking stations and investigate new locations to intensify the cycle hire scheme throughout London. The addition of docking points in key hotspot areas will contribute directly to TfL and the Mayor’s priorities to promote active modes of transport by reducing the barrier of access to a bicycle. The cycle hire scheme aims to provide docking stations in convenient locations on and near Cycleways (previously Quietways and Cycle Superhighways). There is great potential to increase the levels of commuting using the bicycle to and from Central London. Out of the total number of trips completed in a day across London an average of 70 cycle trips either start or finish at each docking station, with the highest usage docking station (Waterloo Train Station) averaging 1000 trips starting and ending per day. Intensification of the cycle hire network will also reduce the number of bicycle redistribution vehicles on the road. As the concentration of sites increases the reliance on manual retribution by vehicles decreases, docking stations become self-sufficient the closer in proximity each site is. This reduces the frequency service vehicles need to visit a site with the exception of maintenance requirements.

Three quarters of members either started cycling or cycled more in London because of the cycle hire scheme. Cycling within London is experiencing rapid growth, especially following the COVID-19 pandemic and through policy initiatives of the Healthy Streets and Active Travel Agenda. It is estimated that there has been an 173 percent increase in the number of cycling trips on London’s major roads since the year 2001 with around half a million cycle trips currently taking place in London every day. The Mayor has set a target to increase the number of cycling trips within London by 400 percent by 2026, and more generally, improve conditions for cyclists.

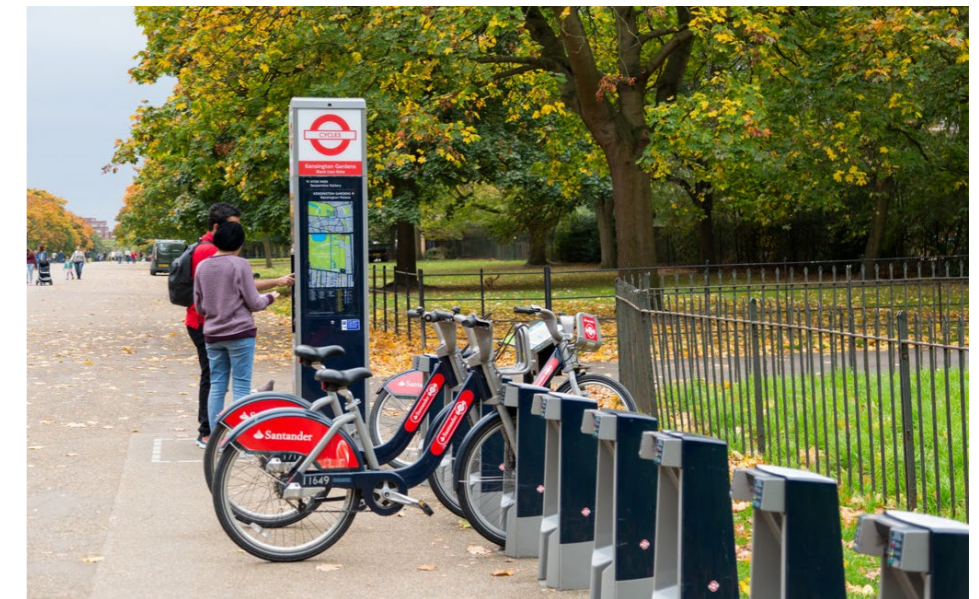

The cycle hire scheme is now a familiar public transport mode which over the last 10 years has helped to achieve growth within the network. The scheme allows people to hire a cycle from a docking station and return it to either the same or another docking station. To ensure the adequate availability of docking points and cycles for those hiring and returning cycles, docking points outnumber bicycles by 70-80 per cent. This is a familiar system which has proven to be effective. The scheme was developed in collaboration with the Royal Parks and the following London Boroughs:

- London Borough of Camden;
- London Borough of Hackney;
- London Borough of Islington;
- Royal Borough of Kensington and Chelsea;
- London Borough of Hammersmith and Fulham;
- London Borough of Lambeth;
- London Borough of Wandsworth;
- City of London;
- London Borough of Southwark;
- London Borough of Tower Hamlets; and
- City of Westminster.

The continued growth of the scheme is supported by the London Plan (March 2021) Policy T5 Cycling which supports development proposals that remove barriers to cycling and create a healthy environment in which people chose to cycle. The success of the cycle hire scheme with leisure users is demonstrated by the top 20 stations for usage being predominantly located near to London's Park and near main rail terminals.

Customer Pulse survey data from 2019 indicates a high level of customer satisfaction, 79 percent of Annual Members rated the overall scheme an 8 or more out of 10. Most of these users were also more likely to recommend Santander Cycles to a friend. A high percentage of users without question mentioned the convenience and value as some of the best things in which the cycle hire scheme has to offer. 56 percent of those surveyed felt general expansion and growth along cycle routes would encourage additional usage of the cycle hire scheme. Cycle hire prompted around a third of current non-users in London to consider the scheme. Hence demonstrating the success of the scheme in spreading the benefits of cycling to a new group of people and increasing the number of cycling trips in London.



Following the success of the Mayor’s Streetspace for London programme (as a response to the COVID-19 pandemic), there are plans to expand the cycle hire network to keep up with the unprecedented demand. May 2020 was the best month in cycle hire’s 10-year lifespan, with 1,120,620 hires. As a result of this, a number of bike hubs are being developed and the aim is to make 1,700 additional Santander Cycles available bringing the total to more than 14,000 (an increase of 15%).

The cycle hire scheme covers the area shown in Figure 1.

Serco Group Plc (Serco) was appointed as the Scheme Operator in 2009.

They worked with the Public Bike System Company (Montreal) to develop the cycle hire scheme in London, based upon the ‘BIXI’ System which successfully operates in Montreal.

Serco design and build sites and operate and maintain the scheme on TfL’s behalf. Their contract includes the following:

- Design and implementation of business support operations and maintenance processes;
- Maintenance of assets;
- Re-distribution of cycles around the scheme area; and
- Customer service centre including the website and user communications

Healthy Streets Initiative

Santander Cycles will play a key role in the delivery the Mayors Transport Strategy by improving the overall health and wellbeing of Londoner’s and working towards the Mayor’s 80% active travel target.

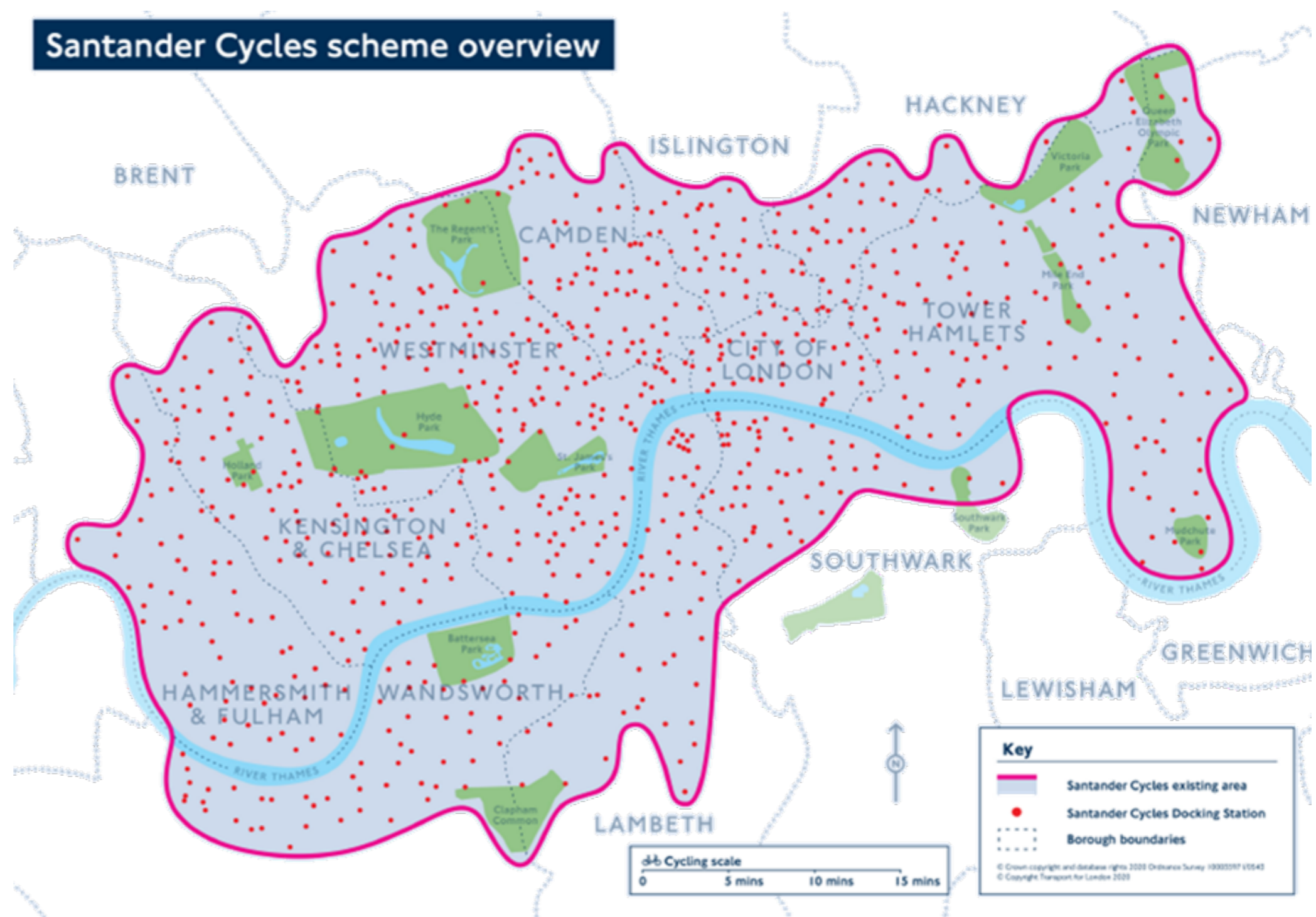

Figure 1: Map showing overview of the Santander Cycle Scheme

Scheme Benefits

- A modal shift from other forms of transport to cycling allowing for 80 per cent of all trips in London to be made on foot, by cycle or using public transport by 2041 (MTS).

- Uptake of Temporary Cycle Lane Streetspace schemes to better improve the cycling network and other pandemic benefits. The added benefit of this scheme is that the bikes get cleaned with antiviral chemicals;

The scheme also:

- Allows a greater choice of public transport options;
- Provides the fastest option for many short journeys;
- Provides a transport mode that is available 24 hours a day, 365 days a year;
- Encourages local trips within London by bicycle;
- Offers a sustainable and low emission form of transport;
- Offers a way to keep fit and lose weight;
- Provides a good way to get to know one's neighbourhood better; and provides an inexpensive transport option.
- Encouraging additional cycle trips in London, and greater uptake of cycling in general. The 2019 survey shows the scheme is attracting those who did not previously cycle;
- Encourage a broader cross-section of the population to try cycling and experience the benefits of low-cost and active travel;
- Helps to remove a number of perceived and real barriers to cycling uptake, such as the expense of buying a bicycle, the fear of bicycle theft, the difficulty of storing bicycles, the lack of opportunities to try cycling for the first time or to improve cycling skills, and the difficulty of finding secure places to park bicycles.

Table 2.5 Trip-based mode shares by type of transport, 2000-2019.

| Year | Public transport | Private transport | Cycle | Walk |
|--------|------------------|-------------------|--------|-------|
| (2000) | (27%) | (48%) | (1.2%) | (24%) |
| 2010 | 33% | 40% | 2.0% | 24% |
| 2011 | 34% | 39% | 1.9% | 24% |
| 2012 | 35% | 39% | 1.9% | 24% |
| 2013 | 36% | 38% | 1.9% | 24% |
| 2014 | 36% | 38% | 2.1% | 24% |
| 2015 | 36% | 37% | 2.2% | 24% |
| 2016 | 36% | 37% | 2.4% | 25% |
| 2017 | 35% | 37% | 2.4% | 25% |
| 2018 | 36% | 37% | 2.5% | 25% |
| 2019 | 36% | 37% | 2.4% | 25% |

Source: TFL City Planning.

Note: Trips are classified by the mode that is typically used for the longest distance within the trip.



Figure 2.7 Mode shares of daily trips in London, 2019.

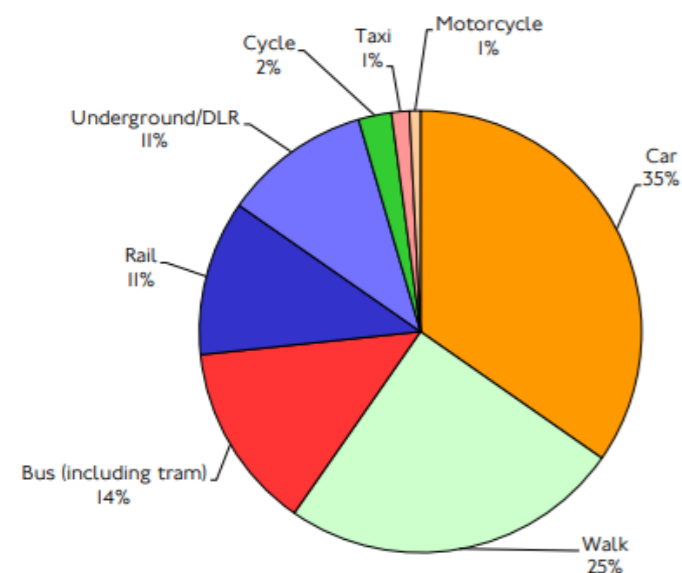

Source: TFL City Planning.



1.2 Site Selection Criteria

A detailed site search to select appropriate sites for docking stations in London has been undertaken by TfL and the host boroughs, based on site selection criteria developed in collaboration with the scheme partners. The criteria takes into account relevant local planning policies, supplementary design guidance, and TfL's own standards and design guidance. The key criteria include:

- No loss of trees and avoidance of grassed areas;
- Sufficient space to maintain clear pedestrian/vehicular paths/access;
- Avoidance of areas of high pedestrian congestion and areas known to be unsuitable for cyclists;
- Safe and secure areas with good natural surveillance, street lighting and/or where appropriate, close circuit television cameras (CCTV);
- Close proximity to where people live and work, and attractors such as tourist destinations, and community and leisure facilities;
- A presumption against sites where the docking station would have a detrimental impact on sensitive townscapes and/or the setting of heritage assets;
- Be sensitive in areas within Areas of Archaeological Interest, using suitable foundations; and
- Flooding / Flood Zones do not impact the cycle hire docking stations due to their careful design and thoughtful mitigation.

Each site is assessed on its merits having regard to its location and the surroundings. Not all the above criteria are relevant to every site.



Docking Station Design

Each docking station comprises a terminal and docking points. The layout of each docking station and number of docking points is tailored to each site, depending on the available space, the proximity to buildings, the presence of street furniture and other relevant criteria previously listed. Docking stations are located on footways, carriageways and other hard-standing areas.

The Terminal

The terminal provides wayfinding mapping of the local area, is a control hub for the locking and releasing of cycles and payment of user tariffs. Also, the terminal itself is a way-finding device by having the recognisable TfL roundel at the top along with the docking station name. For measurement and colour specification refer to Figure 2 below. The TfL roundel is not illuminated. The way-finding maps and information panel can be illuminated on demand to improve visibility for users in poor light conditions.

The footprint of the terminal and its associated circulation area is generally a minimum of 2.0 metres by 2.0 metres (Figure 3), allowing ample space for people to use the terminal without causing obstruction to pedestrians. The exact location of the terminal within the circulation area is dependent on-site characteristics, access to the required connection to electricity, and the need to retain clear pedestrian paths.

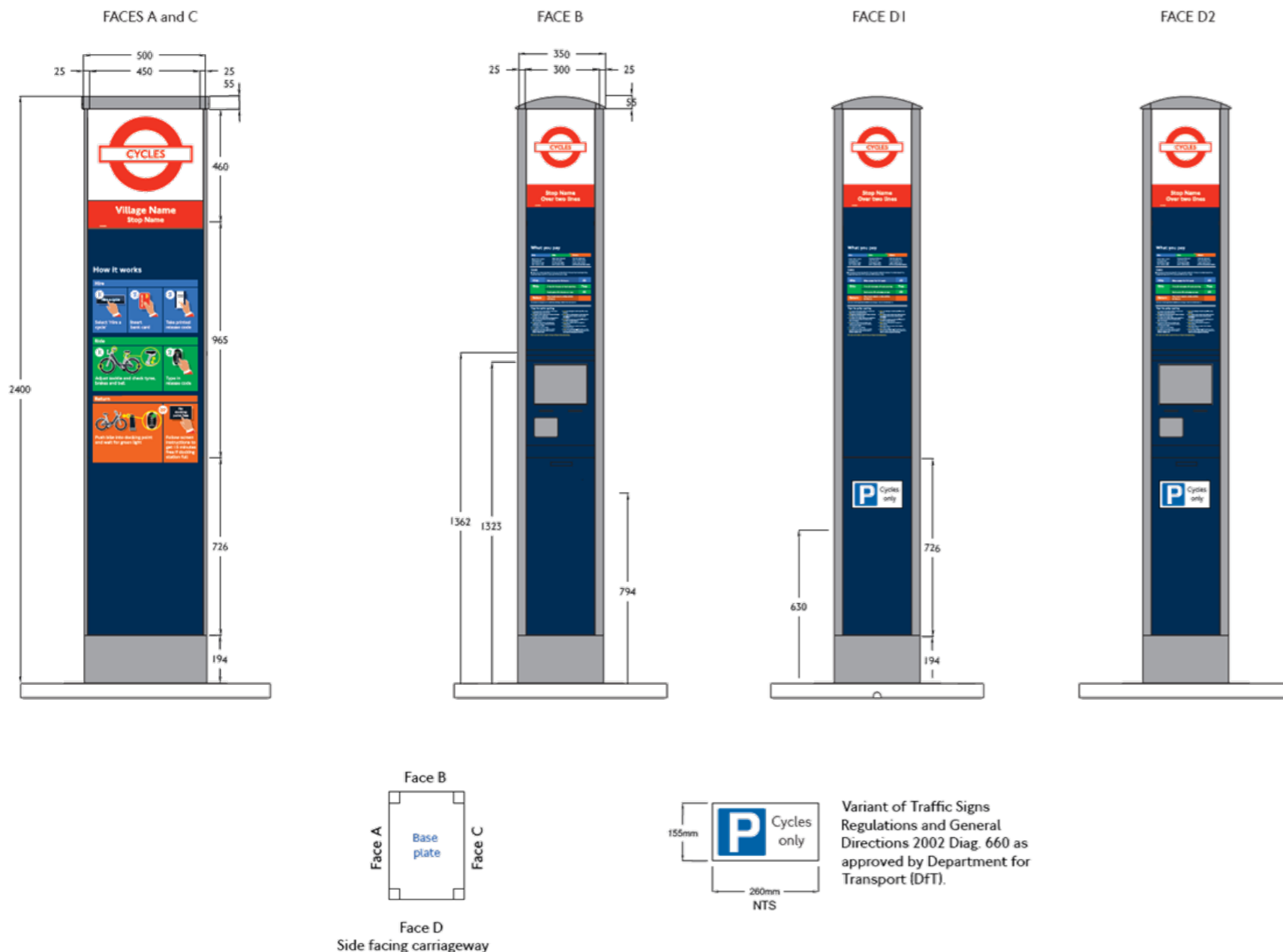

Figure 2: Cycle hire scheme area

MATERIALS:

Housing, panels and doors:

Gravity cast aluminium, powder coated with graffiti resistant coating

Mapping, information and roundel panels:

Toughened glass

Top Cap:

Thermoplastic moulding

COLOUR REFERENCES:

Roundel and stop name panel:

M: 93, Y: 100

Stop name:

White

Terminal body:

NCS S 8010- R90B
(Pantone 296C dark Blue)

Roundel panel background:

NCS S 0500-N (white)

Terminal Trim and Cap/Top:

Silver Grey RAL 9007

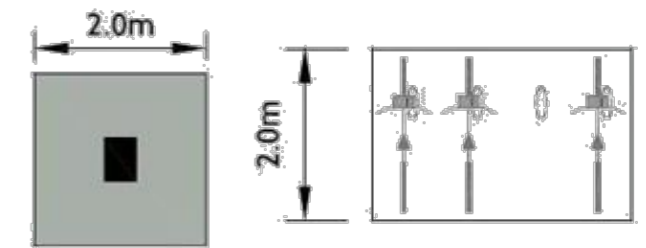

Figure 3: Indicative docking station layout and measurements

NOTE:

For larger or busier docking stations, Faces A & C (Mapping) and Faces B & D2 (registration/payment functionality).

For smaller, less busy docking stations, faces A & C (Mapping), Face B (registrations/payment functionality), Face D1, additional information.

Terminal Information

The terminal presents instructions and important information for the user position shown on Figure 4. The information is split between instructions on how to use the scheme, the pricing and cycle tips.

How it works

| Hire | | |
|-----------------------|------------------|---------------------------|
| 1 | 2 | 3 |
| Select 'Hire a cycle' | Insert bank card | Take printed release code |

Ride

| | |
|--|----------------------|
| 1 | 2 |
| Adjust saddle and check tyres, brakes and bell | Type in release code |

Return

| | |
|---|---|
| OR | No docking point free |
| Push bike into docking point and wait for green light | Follow screen instructions to get 15 minutes free if docking station full |

What you pay

| Hire | Ride | Return |
|---|--|--|
| Select 'Hire a cycle' and follow the instructions to get your release code. | Check your bike and enter the code. On the green light, you're good to go. | Push the bike back into a docking point. A green light means you've successfully docked. |

Costs

It costs £2 to access the bikes for 24 hours and the first 30 minutes of each journey is free. Longer journeys cost £2 for each extra 30 minutes or less.

| | | |
|---------------|--|-------------|
| Hire | Bike access for 24 hours | £2 |
| Ride | First 30 minutes of each journey | Free |
| | Each extra 30 minutes or less | £2 |
| Return | You must return a bike within 24 hours | |

You could be charged up to £300 if you damage a bike or do not return it.

Tips for safer cycling

- Do only use signed cycle routes or roads in the Royal Parks, or you may be fined.
- Do beware of blind spots around large vehicles – it's often safer to hang back.
- Do watch out for other vehicles and pedestrians and show your intentions by always giving clear hand signals.
- Do make yourself seen by wearing bright clothing in the day and reflective clothing or accessories at night.
- Do consider wearing a helmet.
- Do wait in front of other vehicles at traffic lights by using the advanced stop line for cyclists, if there is one.
- Don't ride through red traffic lights – you may be fined.
- Don't cycle on the pavement or the wrong way up one-way streets (unless clearly marked for cyclists).
- Don't get too close to parked cars – beware of car doors opening suddenly.
- Don't use a mobile phone or earphones while cycling.
- Don't ride a bike when under the influence of alcohol or drugs.
- Don't cycle in the gutter – if the road is narrow, it may be safer to ride towards the middle of the lane to prevent dangerous overtaking.

Find out more about cycle training at tfl.gov.uk/cycletraining

Figure 4: Information panels on terminal

The Docking Points

The docking points for the scheme will be placed in a defined area (or areas) adjacent to the terminal. The dimensions of the docking point area(s) will be site dependant and be down to site constraints and characteristics. Each docking point secures one cycle and provide 0.75m between each one once docked, the docking point has a maximum height of 0.8m and dimensions of 0.3x0.3m. The docking points will be angled at either 45 or 90 degrees within the site and have a sloped design to avoid litter and allow rainwater drainage. The cycle will be wheeled into the docking point where it will slot firmly into a secure locking cassette. Each locking cassette has a membership key reader to allow quick release of cycles for cycle hire members.

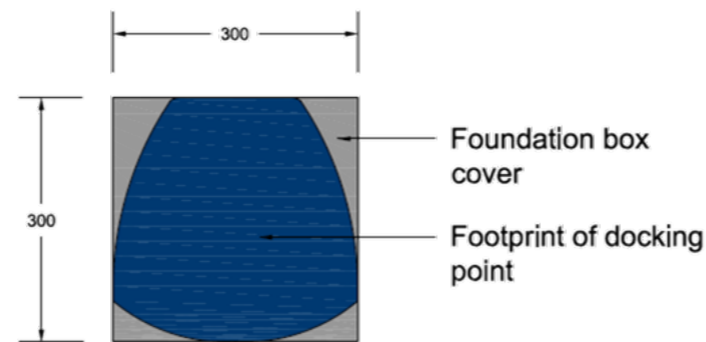

Docking Point and Foundation Box Cover
Plan view at docking point base

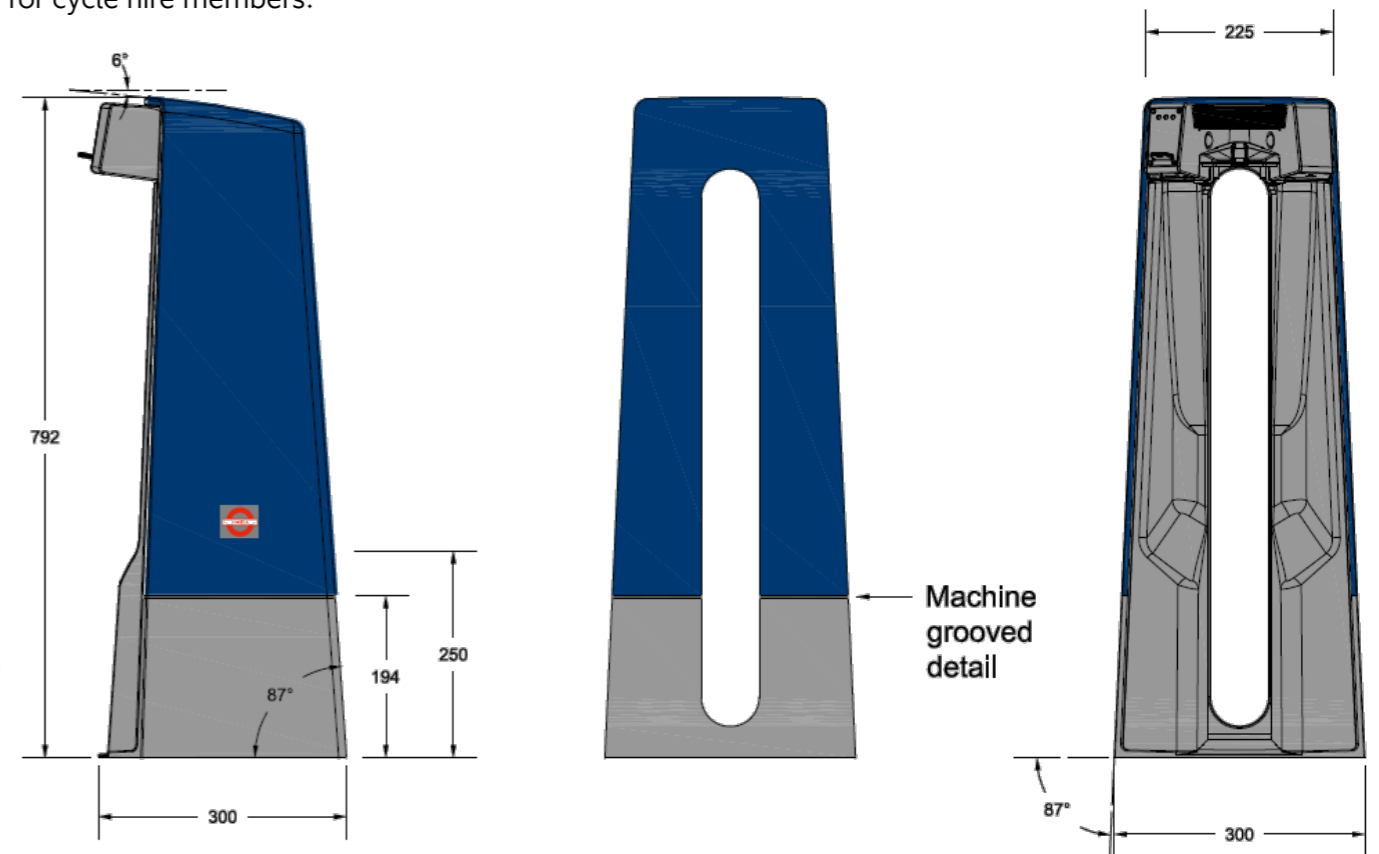

Figure 5: Docking point design

Material
Permanent mould, gravity cast aluminium alloy
A356.2-T61

Finish
Polyester powder coat
Gloss finish

Colours
Dark Blue, Pantone 296C
Silvergrey, RAL 9007

Decal Roundel Colour
Red: M:93, Y:100

Foundation Box Cover
Galvernised steel with anti-slip coating

Standard Foundations

The terminal foundations have a maximum depth of 0.45m (including the surfacing) and a maximum sub-surface plan area of 0.8 x 0.8 metres. The terminal is secured to a square foundation box.

The docking point foundations are 0.318 deep and 0.75 metres wide and are constructed as a trench extending the length of the docking points area. Excavation will not exceed a depth of 0.318 metres from finished ground level. Figure 6 provides a cross section for a footway site. The docking points are each secured to a square foundation box and its corners will be visible around the edges of the docking points. The cover of the foundation box will be finished to a high standard with a non-slip surface (figure 7).

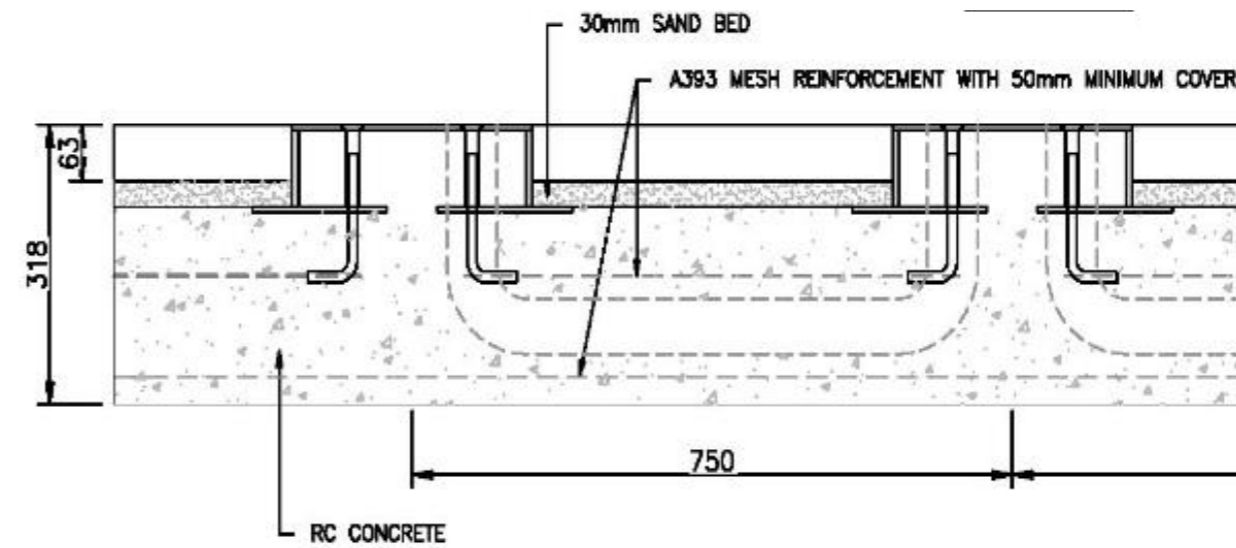

Figure 6: Cross-section of docking point foundations (not to scale)

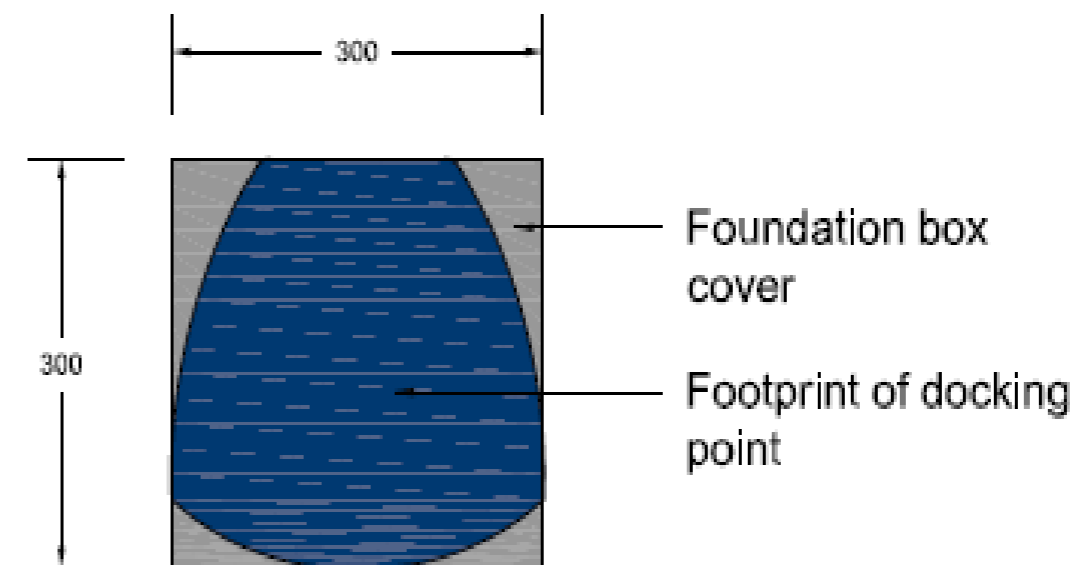

Figure 7: Footprint of docking point at base (not to scale)

Part 2 Access Statement

2.1 Inclusive Access

During the initial design process the views of key access groups, including the Royal National Institute for Blind People, the Guide Dogs for the Blind Association and the Disabled Persons Transport Advisory Committee were taken into account. The resulting docking station design is accessible to all anticipated user groups.

Individual docking points are 0.8 metres in height, which ensures docking points are visible to passing pedestrians. Individual docking points are usually viewed in the context of a row of other docking points, and in combination with docked cycles and a terminal, which further increases their visibility. The terminal is 2.4 metres high and is easily visible above the level of the cycles and docking points.

The wayfinding mapping and information on the terminal, which is also likely to be of relevance to non-cyclists, is of an appropriate height for most users, including wheelchair users. The mapping has been designed to be clear and easy to read and complies with TfL's accessibility standards.

The text on the information panels also meets the appropriate standards with respect to font size and type, as well as colour contrast to background. There is push button illumination of the mapping and information panels.

The terminal incorporates the TfL roundel, a station and locality name to ensure each docking station is easily identifiable and recognisable as a part of the scheme and as a transport mode.

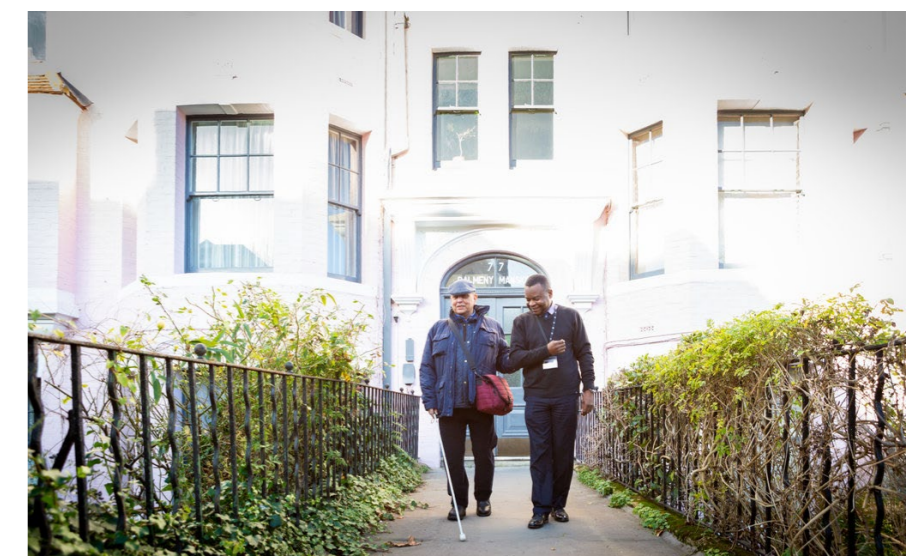

2.2 Pedestrian Circulation

As discussed in Section 1.2 docking station sites have been selected where there is sufficient footway or carriageway width as to not cause obstruction to pedestrians or vehicles.

Docking stations on carriageway sites are usually located against the kerb.

Sufficient space has been provided to enable users to circulate around the terminal and docking points without having to step out into traffic paths. Docking stations on the footway are usually located within the street furniture zone (see Figure 8), or at the back of the footway. In most cases, a minimum of 2.0 metres of clear footway is retained to ensure that the docking station does not impede pedestrian movements, as seen in the TfL Streetscape Guidance.

The docking station is designed to maximise pedestrian circulation within and around the docking points and terminal. There is a gap between individual docking points to allow ease of cycle docking and un-docking, and pedestrian movement between the docking points when they do not contain docked cycles. Depending on site circumstances, the terminal is generally positioned within a 2.0 by 2.0 metre area to provide space for pedestrian circulation and queuing clear of the main traffic flows.

Each docking point has a scheme membership key reader enabling registered users to hire cycles without interaction with the terminal. In busy locations the terminal may have two payment points, or the docking station may have two terminals. These measures minimise queuing and help to maintain a clear footway.

Furniture zone design standards

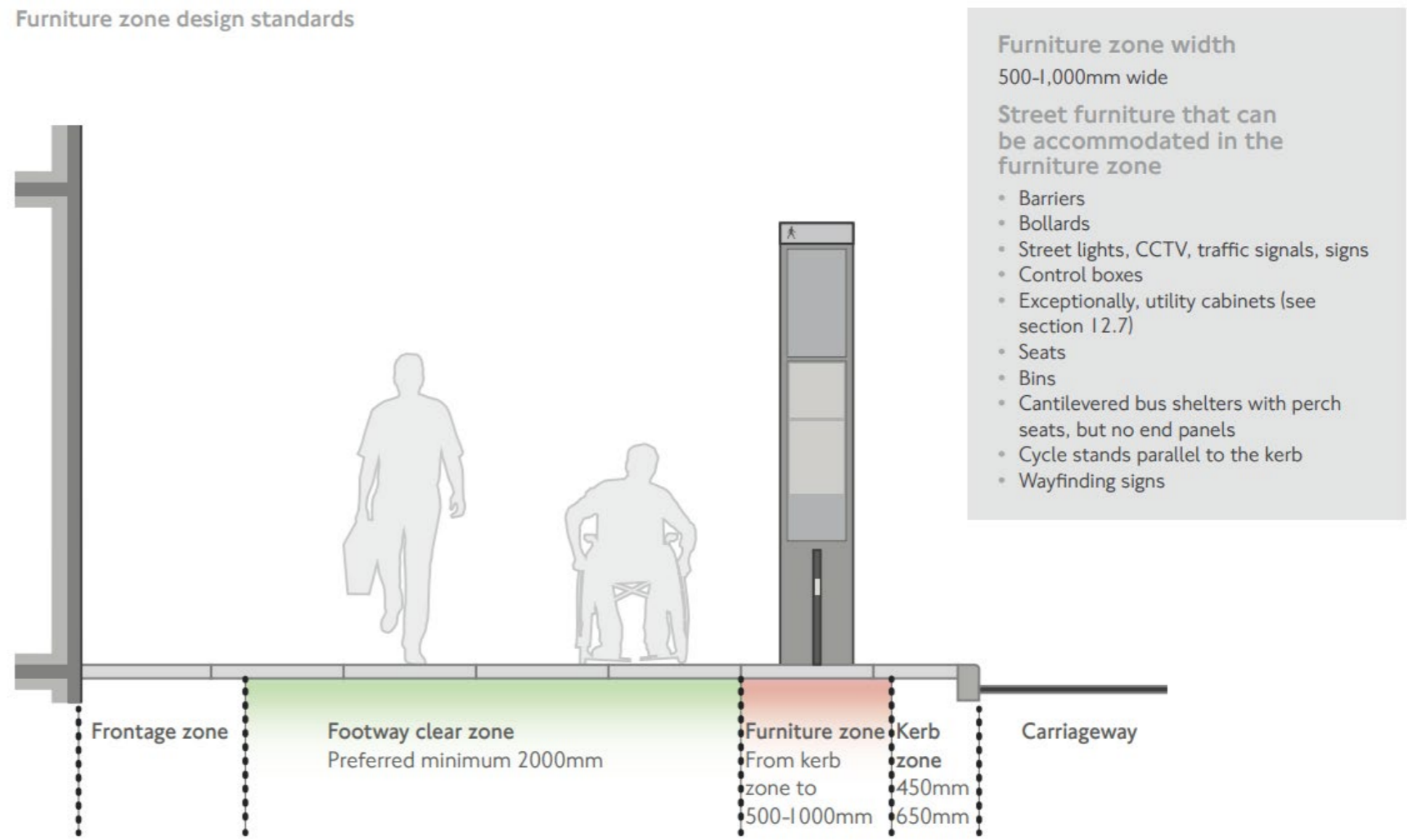

Figure 8: Streetscape Street Furniture Design Standards (TfL)

Part 3 Planning Policy and Guidance

3.1 Introduction

In making a decision on whether to grant planning permission, Section 38(6) of the Planning and Compulsory Purchase Act 2004 (the 2004 Act) requires planning applications to be determined in accordance with policies of the Statutory Development Plan, unless material considerations indicate otherwise. An assessment of the proposal will be undertaken in accordance with the relevant planning policies as follows:

- The London Plan (March 2021);
- Local Plan policy T1 – T4.
- National Planning Policy Framework (NPPF) (2041); and
- Other relevant planning policy

At the national level the assessment of policy compliance focuses on sustainability, transport and design policies. At the regional and local levels, the proposal is assessed against relevant policies within the development plan.



The London Plan (March 2021)

The London Plan 2021 is the Spatial Development Strategy for Greater London. It sets out a framework for how London will develop over the next 20-25 years and the Mayor's vision for Good Growth.

The Plan is part of the statutory development plan for London, meaning that the policies in the Plan should inform decisions on planning applications across the capital. Borough's Local Plans must be in 'general conformity' with the London Plan, ensuring that the planning system for London operates in a joined-up way and reflects the overall strategy for how London can develop sustainably, which the London Plan sets out.

The following policies are considered relevant to this proposal:

Policy GG2 – Making the best of use of land aims to protect and enhance London's open spaces, including the Green Belt, Metropolitan Open Land, designated nature conservation sites and local spaces, and promote the creation of new green infrastructure.

Policy GG3 – Creating a healthy city the main aim is to improve Londoners' health and reduce health inequalities. This include active choices and the Healthy Streets Approach.

Policy D8 – Public Realm makes reference to the contribution the public realm makes to discouraging car travel and how it needs to be utilised to remove barriers of movement allowing for smooth travel of pedestrians and cyclists.

Policy E10 – Visitor infrastructure promotes London's visitor economy and employment and how this should be strengthened. This includes inclusive access and supporting the transport infrastructure which enhances the visitor experience.

Policy SI 1 – Improving Air Quality promotes the use of zero-emission modes of transport and ways in which to improve air quality in London.

Policy T1 – Strategic approach to transport supports the Mayor's strategic target of 80 per cent of all trips in London to be made by foot, cycle or public transport by 2041 and to support the schemes in table 10.1 which cycle hire is part of.

Policy T2 – Healthy Streets Central to the Draft London plan focuses to create vibrant neighbourhoods that are appealing places to walk, cycle and spend time, and providing local people with access to the facilities and services that they need.

Policy T3 – Transport capacity, connectivity and safeguarding outlines that the development of the cycle hire network forms a part of delivering the Healthy Streets approach.

Policy T5 – Cycling looks to create a healthy environment in which people choose to cycle, through the delivery of improved infrastructure.

Policy HCI – Heritage Conservation and Growth seeks to demonstrate a clear understanding of London's historic environments, and states evidence should be used for improving access to, and interpretation of, the heritage assets, landscapes and archaeology within their area.

Policy G1 – Green Infrastructure looks for opportunities to support street trees.

Policy G5 – Urban Greening seeks opportunities to contribute to greening London and making sure existing cover is retained.

3.2 The Development Planning Framework

The Local Plan (2017)

The Local Plan was adopted by Council on 3 July 2017. It has replaced the Core Strategy and Camden Development Policies documents. It is currently the basis for planning decisions and future development in Camden, however work has begun to review and update the Local Plan. Public consultation closes on 13 January 2023.

Between 2006–2014, travel by bicycle increased by 82%. The Council therefore seeks to build on this by improving cycling facilities, routes and creating the conditions that will encourage further take up of cycling.

Strategic objective 8 promotes sustainable transport for all and to make Camden a better place to cycle and walk around, to reduce air pollution, reliance on private cars and congestion, and to support and promote new and improved transport links. Camden plan objective 3, Local Plan policy T1 – T4.

Strategic objective 11 aims to improve health and wellbeing of Camden’s population and reduce health inequalities through good spatial planning, supporting healthier lifestyles and environmental improvements, as well as ensuring appropriate access to health facilities. Local Plan policy C1, C2, C4, A2, CC1, CC2, CC4, A1, A3, D1, T1.

Policy C1 (Health and Wellbeing) will improve and promote strong, vibrant and healthy communities through ensuring a high quality environment with local services to support health, social and cultural wellbeing and reduce inequalities.

Policy T1 (Prioritising Walking, Cycling and Public Transport) promotes sustainable transport by prioritising walking, cycling and public transport in the borough. In order to promote cycling in the borough and ensure a safe and accessible environment for cyclists, the Council will seek to ensure that development provides for and makes contributions towards connected, high quality, convenient and safe cycle routes, in line or exceeding London Cycle Design Standards, including the implementation of the Central London Grid, Quietways Network, and Cycle Super Highways.

Policy CC4 (Air Quality) will ensure that the impact of development on air quality is mitigated and ensure that exposure to poor air quality is reduced in the borough.

Policy D1 (Design) confirms the Council will seek high quality development that respects local context and character and preserves the historic environment and heritage assets, among other considerations.

Policy D2 (Heritage) outlines the Council will preserve and where appropriate enhance Camden's heritage assets and their settings. Camden will not permit the loss of or substantial harm to a designated heritage asset unless it can be demonstrated the public benefits would outweigh the harm or loss.

The Council maintains a rolling three year programme of investment with an annual financial allocation made by TfL to support delivery. These borough wide schemes are also supported by the block grant from Transport for London (part of the Corridors, Neighbourhoods and Supporting Measures programme). Schemes include advanced stop lines for cyclists, a boroughwide 20mph limit, pedestrian signage and wayfinding and cycle hire.

Supplementary Planning Guidance

The Camden Planning Guidance (2011) provides additional advice and guidance for development proposals. The guidance seeks to;

- Ensure that the Cycle Hire Scheme is extended to key destinations. Where appropriate, developments could be required to provide a financial contribution or include a docking station within the development if suitable (Paragraph 9.9 of CPG 7 Transport);

- Provide for connectivity, to, from, around, and through sites for people using all modes of transport. Including pedestrians, cyclists etc (Paragraph 2.9 of CPG 1 Design);
- Respect the built form, character, history, archaeology and nature of existing buildings on the site and other buildings immediately adjacent and in the surrounding area. (Paragraph 2.9 of CPG 1 Design);
- Respect and be sensitive to natural and physical features, both on and off the site. (Paragraph 2.9 of CPG 1 Design);
- Ensure that street furniture does not obstruct pedestrian views or movement or be positioned to encourage anti social behaviour (Paragraph 9.23 of CPG 1 Design).

The Camley Street Neighbourhood plan (2019 – 2034) outlines the shared objective to make the neighbourhood an area that is economically vibrant socially connected and secure; the greenest, safest place to live and work that could possibly be.

Core Objective 4 of the plan outlines that development needs to support and promote sustainable transportation for all its uses throughout the neighbourhood area. In particular, opportunities to enhance the Regents Canal corridor should be explored.



3.3 Other Material Considerations

National Planning Policy Framework

The current version of the National Planning Policy Framework (NPPF) was published in December 2024 and sets out the Government’s planning policies for England. At the heart of the NPPF is a presumption in favour of Sustainable Development. Paragraph 7 states that “At a very high level, the objective of sustainable development can be summarised as meeting the needs of the present without compromising the ability of future generations to meet their own needs”. This includes improving the conditions in which people, live, work, travel and take leisure.

Principle 14 ‘Meeting the challenge of climate change, flooding and coastal change’ outlines the importance of the planning system in helping to secure radical reductions in greenhouse gas emissions, providing resilience to the impacts of climate change, and supporting the delivery of renewable and low carbon energy and infrastructure.

The NPPF also states that planning decisions should aim to achieve places which promote safe and accessible environments and developments, which contain clear and legible pedestrian routes and high-quality public space which encourage the active and continual use of public areas.

The cycle hire scheme provides a sustainable mode of transport which is considered to support the sustainable development principles highlighted in the NPPF, by providing a green infrastructure across London.

The Scheme helps to encourage healthy and sustainable communities and its design has been carefully considered to be innovative and compatible with London streetscapes.

The Scheme helps to encourage healthy and sustainable communities and its design has been carefully considered to be innovative and compatible with London streetscapes.

The Mayor’s Vision for Cycling in London

The *Mayor’s Vision for Cycling* published in March 2013 set out the Mayor’s plans for substantial change in order to treat cycling as an integral part of the transport network.

This was followed up by the *Mayors Vision for Cycling Three Years On, ‘Human Streets’*. Published in March 2016, this document reviews the progress that has been made in London over the past three years in terms of cycling and sets out the priorities for the future.

The Mayor’s Transport Strategy

The *Mayor’s Transport Strategy* published in March 2018 sets policies to improve transport within Greater London. The strategy sets out the Mayors vision, which looks to resolve current problems, primarily a dependence on car, and provide for a city where walking, cycling, and green public transport becomes the most appealing and practical choice for many more journeys. The Mayor’s Transport Strategy (MTS) has a clear focus on mode shift – 80 per cent of Londoners’ trips to be made on foot, by cycle or by public transport; up from 63 per cent today. The MTS Healthy Streets Approach aims to reduce Londoner’s dependency on car usage, where two thirds of car trips could potentially be cycled, with a goal to reduce overall car usage by 10-15% by converting to sustainable modes.

The MTS places high expectations on developers to deliver transport solutions that will promote a shift to active, efficient and sustainable modes such as cycle hire.

Proposals in chapter 3 set the healthy streets approach to improve experience and deliver better quality of live. Proposal 5 and 6 seeks to make it easier to walk and cycle in London. This includes increasing the use of the cycle hire scheme to broaden the appeal of cycling in London. The strategy also recognises the health benefits of cycling in Policy 2, which seeks to promote healthy travel options.

The Healthy Streets Approach is at the heart of the Mayors Transport Strategy. This seeks to use the ten ‘indicators’ to improve quality of life on streets. This includes approaches such as removing clutter and improving the layout, design and attractiveness of streets; and creating clear and easily understandable routes and spaces to make it easier for cyclists, pedestrians and disabled people to get about.

Within this is also included the Active Travel agenda with the aim of 20 minutes of active travel a day, to help improve the health and wellbeing of the population.

The Mayor’s Climate Change Mitigation and Energy Strategy

Delivering London’s energy future was adopted in October 2011. The Strategy sets out a strategic approach to reduce carbon emissions from a range of sources, including London’s transport.

Action 10.5 under Policy 10 promotes the development of the London cycle hire scheme as part of a shift to more carbon efficient modes of transport.

The Mayor's Air Quality Strategy

Clearing the Air was published in December 2010 following public consultation. It sets out the Mayor's plans to improve air quality in the Capital, including the reduction of air pollution from London's transport.

Cycle hire is included in the Strategy as one way to promote a shift to cleaner forms of transport (Policy 1: encouraging smarter choices and sustainable travel). It also notes that the eastwards expansion of the scheme, combined with public transport improvements, will help to achieve behavioural change away from the car to more sustainable modes.

The London Health Inequalities

The Mayor published his first ever Health Inequalities Strategy in April 2010, along with an accompanying 'action plan', First Steps to Delivery. The cycle hire scheme is supported by objective 5 (Healthy places), which states:

"Efficient and affordable transport systems can also help to tackle health inequalities. The Mayor's Transport Strategy emphasises the need to reduce congestion, reduce transport related carbon emissions, improve the reach and reliability of London's public transport system and increase the number of people walking and cycling which will be greatly helped by the introduction of the cycle hire scheme".

The Scheme can help to reduce health inequalities by encouraging active travel and providing a low-cost form of transport to access employment and services, and therefore supports this strategy. The expansion of the Scheme will bring these benefits to a wider group of people.

Cycling Revolution London

Within Cycling Revolution London (May 2010) the Mayor states that cycling has an important role to play in the future of the Capital and affirms that it is the "single most important tool for making London the best big city in the world". The cycle hire scheme is the centrepiece of the cycling programme to make London a genuine cycle-friendly city.

Sustainable Future for Cycling

Sustainable Future for Cycling published in January 2008 sets out the Government's planning policy direction regarding cycling. It recognises the important contribution of cycling as a sustainable form of transport and how cycling contributes to climate change; health, security and safety; quality of life; and equality of opportunity.

3.4 Streetscape Design Guidance

Streetscape Guidance: A guide to better London streets

Streetscape Guidance: Fourth Edition Revision 2 (2022) prepared by TfL gives guidance on streetscape issues and shows how the Mayor's Better Streets objectives may be achieved. The document advises on key design principles including:

- Consistency and clarity;
- Integration and co-ordination;
- Design for people;
- Reduction of crime and disorder;
- Function and safety;

- Materials and maintenance; and
- Recognition of local context and distinctiveness (including local heritage and its statutory and local designations).
- Breathing new life into the public realm
- Bolder designs that will transform streetscapes into welcoming places
- Designs which require higher levels of ambition, innovation and creativity
- Making sure streets and roads fulfil the six keys roles: Moving, Living, Unlocking, Functioning, Protecting and Sustaining.

The Scheme delivers a high-quality design which is in line with these principles.

The London Cycling Design Standards

The *London Cycling Design Standards* (2014), prepared by TfL, sets out design guidance and indicative standards for all cycle schemes in London. Of particular relevance is Chapter 8 which notes the increasingly important role of cycle hire in facilitating choice in access to and onward journeys from a transport interchange. Chapter 8 also states that cycle parking should be an integral part of streetscape design and explains how cycle stand design and location can complement the existing streetscape.

Part 4 Site and Proposal

4.1 Surrounding Environment, Site Characteristics & Proposal

Site Description and Location

The site is located on the carriageway adjacent to Truro House, Mount Pleasant, WC1X 0AE. The proposed docking station would be located where there are currently pay by phone and resident permit holder parking spaces. While not part of this application, it is understood the existing permit holder spaces on the site would be relocated to Elm Street as stated in the [Mount Pleasant New Cycle Hire Docking Station Consultation](#) while the pay by phone spaces would be removed.

The London Borough of Camden have received funding, via legal agreement to provide a new Santander cycle hire docking station from the neighbouring Postmark development. The proposed location was chosen for the new docking station as it presents a prime location to expand TfL's network of Santander cycle hire docking stations. 78.4% of households in the Mount Pleasant area do not own a car and rely on walking, cycling and public transport to make their journeys. Many residents in the area are excluded from cycling due to lack of access to a bike. As a result, expanding the existing Santander cycle hire network will help provide the opportunity for residents to travel sustainably.

On the 6th January, Camden began a consultation on the proposed docking station (numbering 25 docking points) which has since closed. The results of the consultation have yet to be announced and the proposed docking station will only be installed if Camden's Committee approve the works.

The site itself is not situated in an archaeological priority area, nor is it located in a conservation area (CA), although the Hatton Garden CA is situated immediately to the east of the site with the boundary set in the middle of Mount Pleasant. 47 – 57 Mount Pleasant are Grade II listed and situated on the eastern side of the street. The site is situated in Flood Zone I according to the Environment Agency's Flood Risk Map and therefore has a low probability of flooding.

The site is situated circa 825 metres east of Russell Square underground station and 630 metres to the south east is Farringdon Train Station which provides the closest national rail service. There are also a number of well-linked bus locations in the area able to take passengers to a variety of destinations around the City.

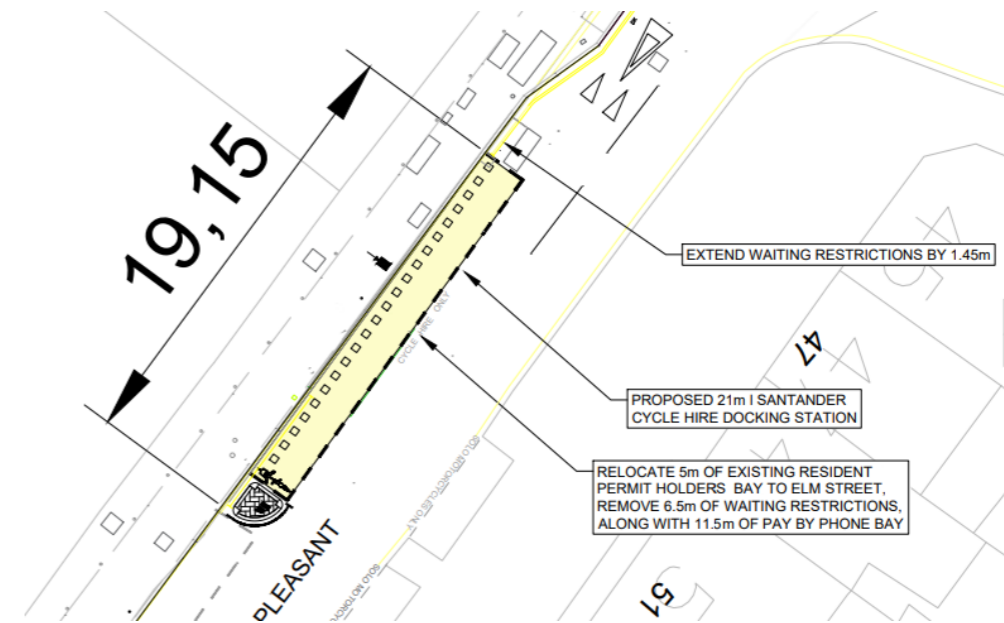

Figure 9: Extract of proposed docking station, sourced from the Mount Pleasant consultation.

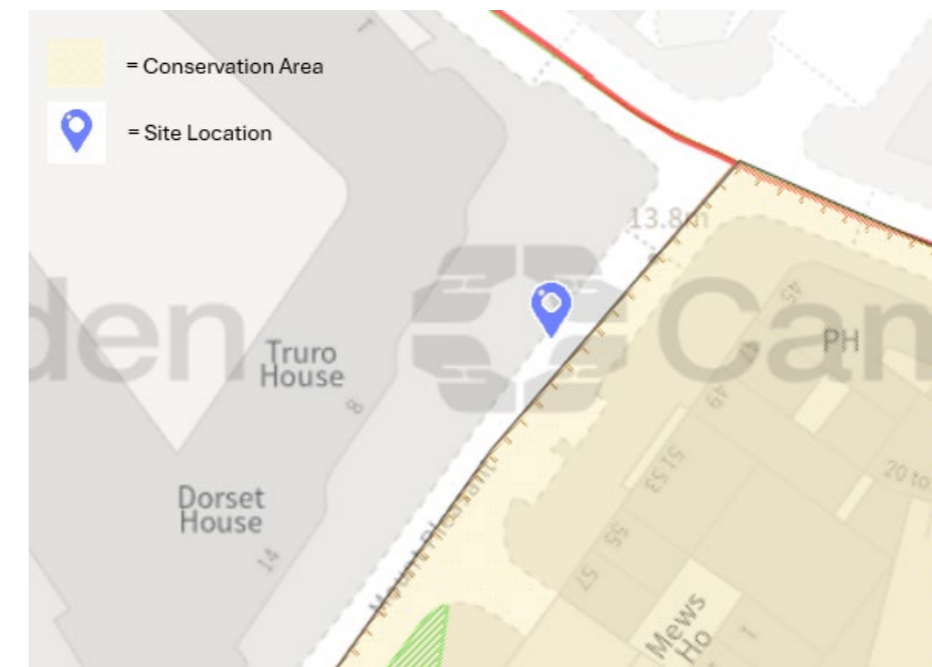

Figure 10: Extract from Camden's Interactive Policies Map.

4.4 Key Considerations and Assessment

Access and Design

In selection of the site consideration has been given to the existing function of the carriageway and the context of the surrounding buildings. Due to the docking stations location, it will be viewed in the context of the carriageway and will strengthen transport and public function of this space (Figures 13 & 14).

The location of the docking station in the carriageway means the footway will be uninterrupted. While there are existing parking spaces situated on the application site these are proposed to be relocated / removed as part of Camden's Mount Pleasant public realm changes and their removal / relocation do not form part of this application.

The neutral design of the proposed docking station ensures the proposals does not detract from the existing character and appearance of the area.

The docking station is of a maximum height of 0.8 metres, this will help to limit its presence within the street scene. The quick and quiet design of the docking station and terminal will also ensure minimal disturbance to any residents nearby.

This conforms to the London Cycling Design Standards (2014). Transport links in the vicinity comply with The London Plan Policy T1, D8 and T3. This supports the overall vision of the London borough of Camden's Local Plan Strategic Policy 7 and policy T1. Overall this backs the Mayor's Cycling Vision..

Streetscape Character and Amenity

The docking station has been designed to fit within the context of the existing street scene.

The materials of the docking station will compliments street furniture within the context of the site. The size and the dark blue colour of the terminal and the layout and the size of the docking points have been carefully chosen to ensure the docking station integrate with the surrounding environment. The colour also complements the existing hues of London signage, bollards and railings.

The proposal is consistent with The London Plan polices GG2 – Making the best use of land and D8 Public Realm as is helping to improve this area. It also supports policy T2, G4 and G6. This scheme is also in accordance with Camden Local Plan Strategic Policy 11 and Policy D1.

Archaeology

The site is not within an archaeology priority area.

Heritage

As previously outlined, 47 – 57 Mount Pleasant are Grade II listed and located on the eastern side of Mount Pleasant, approximately 12 metres from the application site. The site does not fall within a conservation area but the boundary of Hatton Garden Conservation area is immediately to the east, starting in the middle of the street. As a result, TfL heritage advisors were consulted on the proposal.

Given the size, scale and location of the docking station being situated in the carriageway it is considered the docking station will integrate well into the street scene and be viewed in the context of the carriageway. The proposal is typical of public transport infrastructure across London and is considered to preserve the street scene and the setting of the adjacent Conservation Area.

Due to the separation distance between the docking station and listed buildings along with planting and street furniture between the site and listed buildings, it is not considered the proposal will result in any adverse impact on the setting of the listed building in compliance with Policy D2 of the Camden Local Plan.



Figure 13: Extract from Historic England's Listed Building Map.

Biodiversity net gain

In England, Biodiversity net gain (BNG) is now mandatory under Schedule 7A of the Town and Country Planning Act 1990 (as inserted by Schedule 14 of the Environment Act 2021). From the 12th February 2024 major developments have had to deliver 10% BNG on a development site and from the 2nd April 2024 small sites are now also required to meet this standard.

However, the '[The Biodiversity Gain Requirements \(Exemptions\) Regulations 2024](#)' outlines the type of development that are exempt from mandatory BNG requirements. This includes 'De minimis development'.

Under the '[De minimis exemption](#)' the legislation outlines;

"(1) The biodiversity gain planning conditions does not apply in relation to planning permission for development which meets the first and section conditions.

(2) The first condition is that the development does not impact an onsite priority habitat.

(3) The second conditions is that the development impacts-

(a) less than 25 square metres of onsite habitat that has biodiversity value greater than zero; and;

(b) less than 5 metres in length of onsite linear habitat. "

The application site has a biodiversity value of 0 being made up of hardstanding. The development does not impact a priority habitat nor is there more than 25sqm of onsite habitat with a biodiversity value greater than 0 or more than 5 metres of onsite linear habitat. Thus, the proposed development is exempt from the BNG requirement.

Part 5 Implementation, Maintenance and Operation

5.1 Implementation

In addition to planning permission, other consents and orders, including a Traffic Regulation Order, will be sought for all docking stations. All preparatory works, including the installation of ducting to provide power and communications, will be undertaken prior to the installation of the docking station. Where the site is not located on part of the TfL road network, the works will be undertaken with the agreement of the relevant borough or other landowner.

Construction will normally take place over approximately 8-10 working days, and a 10-day New Roads and Streetworks Act permit will be sought to allow for site set-up and appropriate reinstatement.

As the foundation depth for the terminal and docking point structures will be a maximum of 0.45 metres (including surfacing), the duration of excavation activities will be limited.

Within the 8-10 working days, the terminal and docking points are also installed and the equipment tested. This involves connecting the electrical cables and bolting to the foundations. These are relatively quiet operations.

5.2 Maintenance and Redistribution

Each docking station is inspected by maintenance staff at least every 14 days to ensure all equipment is fully functional and a high standard of station cleanliness is maintained. Any damage identified during this visit is repaired on site where possible or reported for follow-up action if necessary. Where repair is not possible, an operational vehicle is directed to the station to collect and remove the equipment to the maintenance depot for repair. This inspection usually occurs during daytime hours when visibility is best and by a single member of staff on a scheme cycle. Docking stations are also visited when faults or damage are reported by users. The noise generated by these activities is not anticipated to cause any disturbance.

The scheme's success relies on the redistributions of the cycles across the network and therefore affecting the available docking point slots between each hire session. It is necessary to redistribute bikes across the network in some locations, particularly where bicycles are used by commuters at peak hours between 7am and 10am. Therefore issues do not arise, such as being unable to hire a cycle due to the docking station being empty or being unable to return a cycle due to the docking station being full.

Redistribution vehicles such as a van or trailer are used, with a ramp, to allow for efficient and quiet loading/unloading. These vans are only sent when required but the preferable time for this to occur is at night due to the quick response time. This ensures that the servicing of the docking station minimises adverse impacts on surrounding properties.



5.3 Operation

Docking stations are available 24-hours, seven days a week with the most popular periods of use being weekday mornings and early evenings. The majority of patrons using the docking station during peak weekday times are members who can access them quickly by simply inserting their membership key into a docking point to release a cycle. Casual users access the terminal, pay using card or digital currencies, and receive a cycle release code. Which they will enter using the touch sensitive numbered pad located above the key slot on the selected docking point. Also, the Santander Cycles app is the newest technology available to users, this enables quicker use as avoids the need for terminal access:

- It sends the release code directly to your mobile phone
- Let's you see cycle and docking space availability
- Check recent activity (hires and charges)
- Has a journey planner feature to plan routes
- Save your favourite docking stations; and
- Has an interactive map to search for stations, landmarks and street names.

This is available on iPhone and Android devices.

The noise level associated with using the terminal is comparable to bus patrons using a ticket machine located at a bus stop, or to people viewing Legible London way-finding maps. The locking mechanism used to secure cycles to the docking points utilises innovative technology developed for the Public Bike System in Montreal. The design has been carefully optimised to ensure that

the risk of cycles being stolen is minimised. The docking point has been designed to guide the user to wheel the cycle into the correct position to easily engage the locking mechanism.

The locking mechanism is contained within the docking point and the progress of locking and unlocking of cycles is indicated by discrete lights on the locking cassette. The release and re-docking of the cycles is expected to occur without any discernible noise. These design features all provide a streamlined system of releasing and locking cycles that is quick, easy, and efficient.

Contractual arrangements between TfL and Serco (the Scheme Operator) regarding maintenance, repair and replacement ensure the appearance of the docking station meets appropriate standards. A key objective has been to minimise the physical depreciation of the street furniture through design by, for instance, the use of curved edges on equipment and the selection of robust materials and finishes that are easy to maintain.

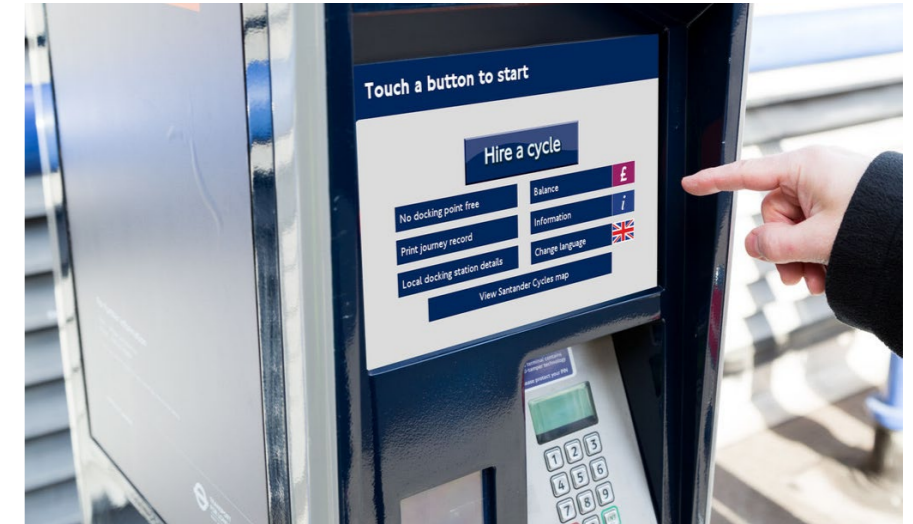

Application Summary

As demonstrated by this Planning, Design and Access statement the docking station on the carriageway adjacent to Truro House, Mount Pleasant, will fully support National and Local Planning Policies and Streetscape Design Guidance. As well as demonstrating high quality street furniture design and ease of access for users. In addition to the wider benefits which are outlined in Section 1 the cycle hire scheme will:

Meet the Borough's site selection criteria (outlined in Section 1.2);

Ensure the delivery of the cycle hire scheme network is at the required density;

Provide a well-considered design that is compatible with the activities and functions of the Central Activity Zone;

Provide a well-considered design that maintains the character of the Conservation Area and the adjacent listed buildings;

