

# SAVILLE THEATRE

135 SHAFTESBURY AVENUE

VENTILATION STATEMENT

HOARE LEA

## Audit sheet.

Rev.	Date	Description of change / purpose of issue	Prepared	Reviewed	Authorised
P01	25/01/24	Preliminary issue for comment	MW	AP	AP
P02	30/01/24	Issued for planning submission	MW	AP	AP
P03	31/01/24	Reissued for planning submission	MW	AP	AP
P04	24/01/25	Revised planning submission	MW	AP	AP

This document has been prepared for YC Saville Theatre Limited only and solely for the purposes expressly defined herein. We owe no duty of care to any third parties in respect of its content. Therefore, unless expressly agreed by us in signed writing, we hereby exclude all liability to third parties, including liability for negligence, save only for liabilities that cannot be so excluded by operation of applicable law. The consequences of climate change and the effects of future changes in climatic conditions cannot be accurately predicted. This report has been based solely on the specific design assumptions and criteria stated herein.

Project number: 0512575

Document reference: REP-0512575-08-MW-20240125-Ventilation Statement - P04.docx

## Contents.

Audit sheet.	2
1. Introduction	4
2. Summary of Kitchen Ventilation Systems	4
3. Theatre Kitchen Ventilation	4
4. Restaurant Kitchen Ventilation	6
5. Hotel Kitchen Ventilation	8
6. Appendix – Supporting information	9

## 1. Introduction

This ventilation statement has been prepared to summarise the proposed measures to be taken to control odour from catering activities at the Saville Theatre development at 135-149 Shaftesbury Ave, London WC2H 8AH.

Planning permission is sought for the following:

*Part demolition, restoration and refurbishment of the existing Grade II listed building, roof extension, and excavation of basement space, to provide a theatre at lower levels, with ancillary restaurant / bar space (Sui Generis) at ground floor level; and hotel (Class C1) at upper levels; provision of ancillary cycle parking, servicing and rooftop plant, and other associated works.*

The various catering areas proposed within the redevelopment are set out below. Although at this stage the final type of cooking to be conducted within these facilities is subject to future agreement with operators, allowances have been made within the proposed MEP systems for very high levels of odour, smoke, moisture and grease control in accordance with the London Borough of Camden (“LBC”) Local Plan 2017 and Supplementary Planning Advice documents, in particular policy CC4 Air Quality. This also aligns with the visions set out in LBC’s policies G1 Delivery and Location of Growth and D1 Noise.

All odour control measures will in general follow the guidance within Defra document ‘Guidance on the Control of Odour and Noise from Commercial Kitchen Exhaust Systems’ and EMAQ+ document ‘Control of Odour and Noise from Commercial Kitchen Exhaust Systems’. Kitchen ventilation systems will be designed and installed in accordance with the guidance set out in BESA Specification for Kitchen Ventilation Systems (DW/172).

## 2. Summary of Kitchen Ventilation Systems

Within the proposed redevelopment of the building, the following catering facilities will be provided:

Location	Tenure	Brief description and level of use
B3	Theatre kitchen	Reheat kitchen - light meals
B2	Theatre kitchen	Reheat kitchen - light meals
B1	Theatre kitchen	Reheat kitchen - light meals
Ground floor	Restaurant kitchen	Commercial kitchen
Level 5	Hotel pantry	Reheat kitchen - light meals

## 3. Theatre Kitchen Ventilation

Within the theatre there are three areas proposed as light kitchens. These will not be full commercial kitchens, rather these will provide facilities for light cooking activities and reheating food. The kitchens will be all electric and will not include any solid fuel cooking. Due to the lighter nature of cooking activities, a recirculating kitchen extract unit is proposed in each of these kitchens. An example of this type of unit is the Reco-Air product manufactured by Halton. Figure 1 provides an image of a typical installation is provided below.

This system is connected to a cooking canopy above the cooking area. The unit requires a modest supply and extract ventilation from the back of house theatre ventilation system. The units are typically constructed from galvanised steel and comprise a large grease particle removal filter, a fine grease particle removal filter, a smoke removal filter, activated carbon filters for odour removal, an EC plug fan and ancillary controls. Various upgrades are available to deal with different types of cooking equipment. A typical data sheet is provided in the Appendix.

A supply air connection from the theatre back of house ventilation system will provide outdoor air into the kitchen space. A modest extract duct, if required, will be taken to discharge at atmosphere. This extract duct

will be much smaller than a conventional kitchen extract duct. A typical plant configuration for the theatre kitchens is shown in figure 2.



Figure 1 Typical installation of a recirculating kitchen extract unit (Image courtesy Halton)

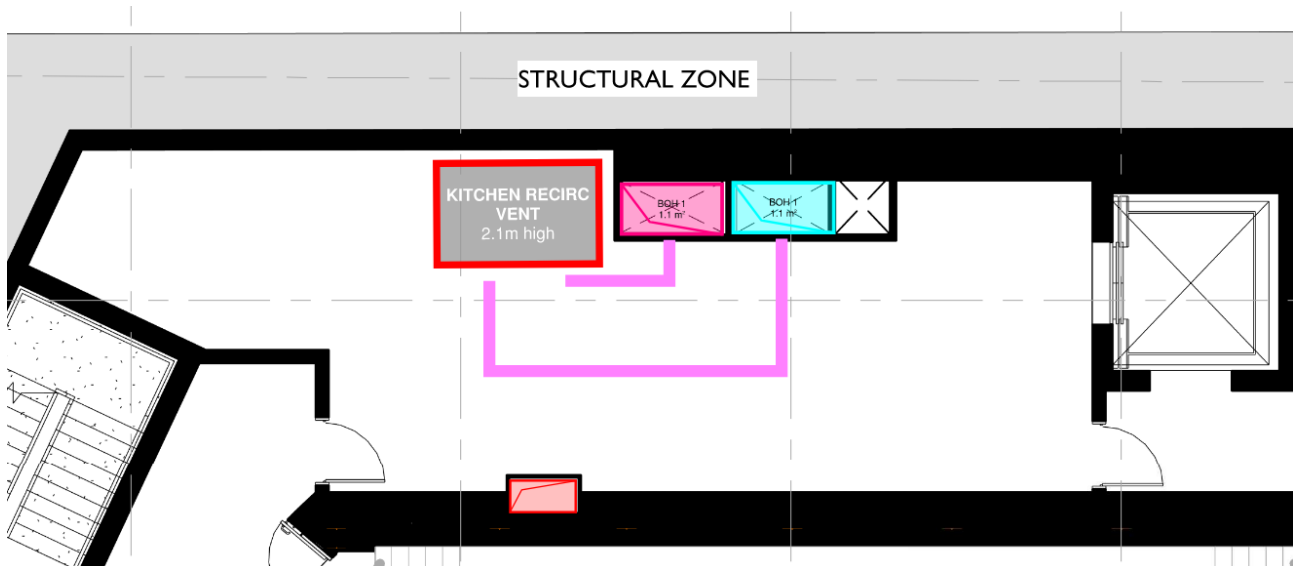

Figure 2 Typical theatre kitchen plant configuration

## 4. Restaurant Kitchen Ventilation

The proposed ground floor restaurant will feature a commercial grade kitchen ventilation system. Although at this stage the final type of cooking to be conducted within these facilities is subject to future agreement with operators, allowance has been made within the proposed MEP systems for very high levels of odour, smoke, moisture and grease control in accordance with the Local Authority planning documents referenced above.

Measures will be taken to remove grease as close to the source as possible, by incorporating appropriate technology into the extract canopies above the installed cooking appliances. Grease separators will be provided in all extract canopies to act as an initial stage of filtration for extract airstreams, safely collecting and depositing grease to limit what is carried into the plenums and ductwork systems.

In addition, ultraviolet (UV) light technology will be integrated into extract canopies to further enhance grease removal from the extracted airstreams prior to connection to the main header ductwork.

Where any solid fuel appliances are specified, consideration will be given to the use of water wash and/or water mist systems. These systems will also be considered where appropriate to further enhance grease removal from the extracted airstreams, for example where very high levels of grease are expected from cooking activities.

From each canopy, kitchen extract ductwork will generally be routed via internal voids and risers to roof level, at which point it will connect to a packaged kitchen extract air handling unit. Suitable cleaning access will be provided through access doors and hatches in strategic locations along the route of the ductwork, in accordance with the recommendations of BESA publications DW/172 and TR/19.

The air extracted from above the cooking area will be induced into a canopy and will pass firstly through electrostatic precipitators (ESPs), which will act to further reduce the size of grease and smoke particulate matter to a level invisible to the naked eye, to limit deposits within the ventilation infrastructure, and to prolong the life of the final stage filters.

Following the ESPs, kitchen extract ductwork will connect to packaged kitchen extract air handling units, comprising appropriate component sections to filter the airstreams prior to exhausting to atmosphere. Each air handling unit will consist of a G4 panel filter and F9 bag filter, E11 HEPA filter and carbon filter. These measures will act to eliminate odours, reduce any smoke to below levels visible to the naked eye and absorb any surplus ozone resulting from the implementation of UV light technology.

Figure 3 below provides an example of a typical kitchen extract air handling unit, and identifies the grease, smoke and odour control measures referenced above:



Figure 3: Typical kitchen extract air handling unit configuration

Vitiated air will be discharged to atmosphere via suitable duct-mounted attenuators, sized to ensure the air handling equipment and associated systems do not exceed the permitted background noise levels. Noise attenuation will be enhanced by directing exhaust airstreams away from noise sensitive receptors wherever feasible. In addition, packaged air handling equipment will be manufactured using acoustically rated casing components to limit case radiated noise to within the permitted external limits.

Figure 4 shows the proposed layout of roof level plant, including kitchen ventilation equipment. The ductwork will be located underneath a gantry that supports other plant items, however provision will be made for access through the gantry to the kitchen extract ductwork below for cleaning purposes. The fan is located on the plant gantry deck and has sufficient space for maintenance and replacement of any faulty parts.

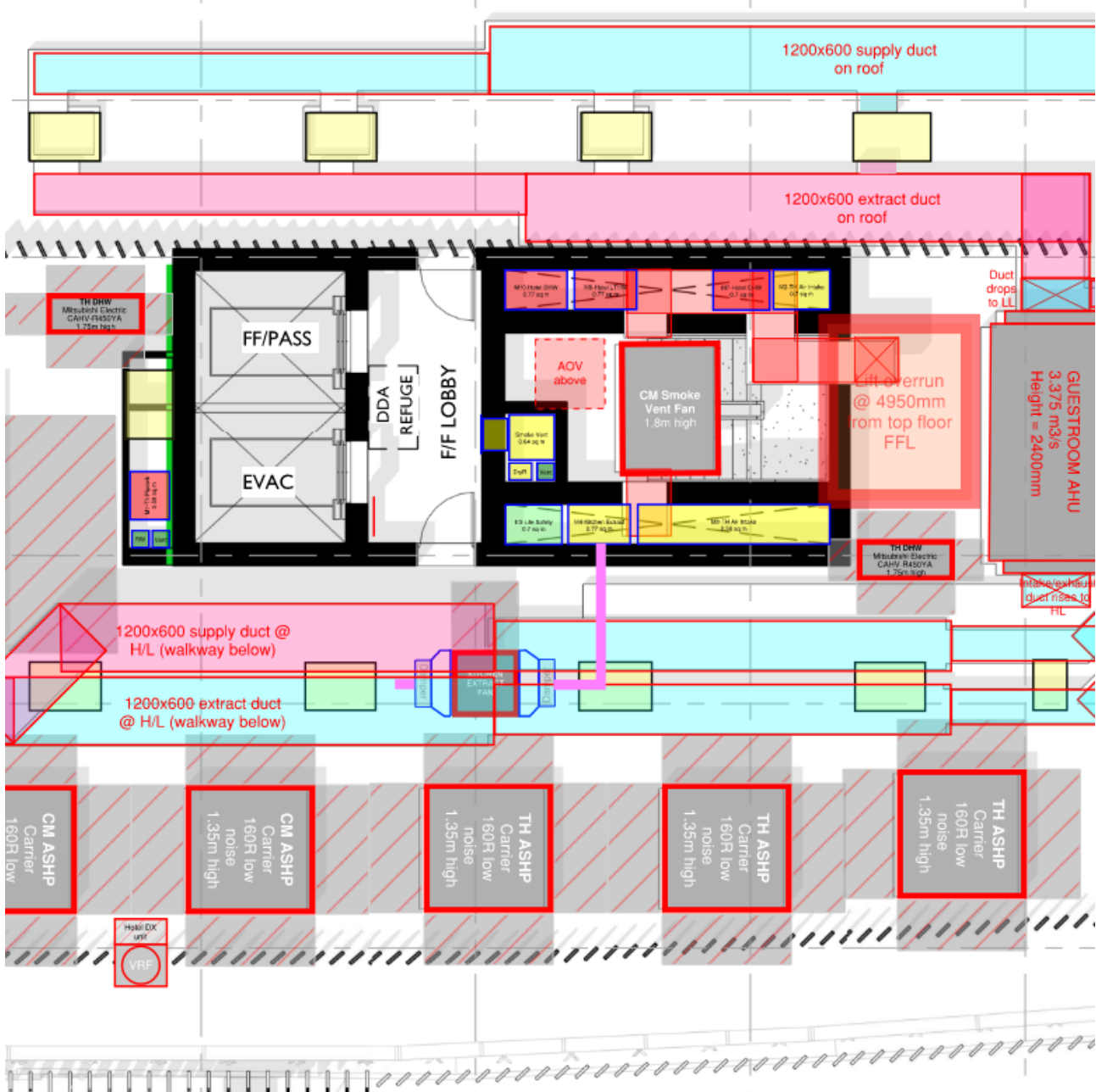

Figure 4: Proposed layout of roof including kitchen extract ventilation plant.

## 5. Hotel Kitchen Ventilation

A light kitchen facility is proposed for level 5 of the proposed hotel development. This will not be a full commercial kitchen, rather it will provide facilities for light cooking activities and reheating food. The kitchen will be all electric and will not include any solid fuel cooking. Due to the lighter nature of cooking activities, the same recirculating kitchen extract unit that has been proposed for the theatre kitchens is also proposed for the hotel kitchen.

The hotel system is connected to a cooking canopy above the cooking area. The unit requires a modest supply and extract ventilation from the local extract ventilation louvres integrated into the facade. The unit will be typically constructed from galvanised steel and comprise a large grease particle removal filter, a fine grease particle removal filter, a smoke removal filter, activated carbon filters for odour removal, an EC plug fan and ancillary controls. Various upgrades are available to deal with different types of cooking equipment. A typical data sheet is provided in the Appendix.

A supply air connection from the hotel front of house ventilation system will provide outdoor air into the kitchen space. A modest extract duct, if required, will be taken to discharge at atmosphere. This extract duct will be much smaller than a conventional kitchen extract duct. A typical plant configuration for the theatre kitchens is shown in figure 5.

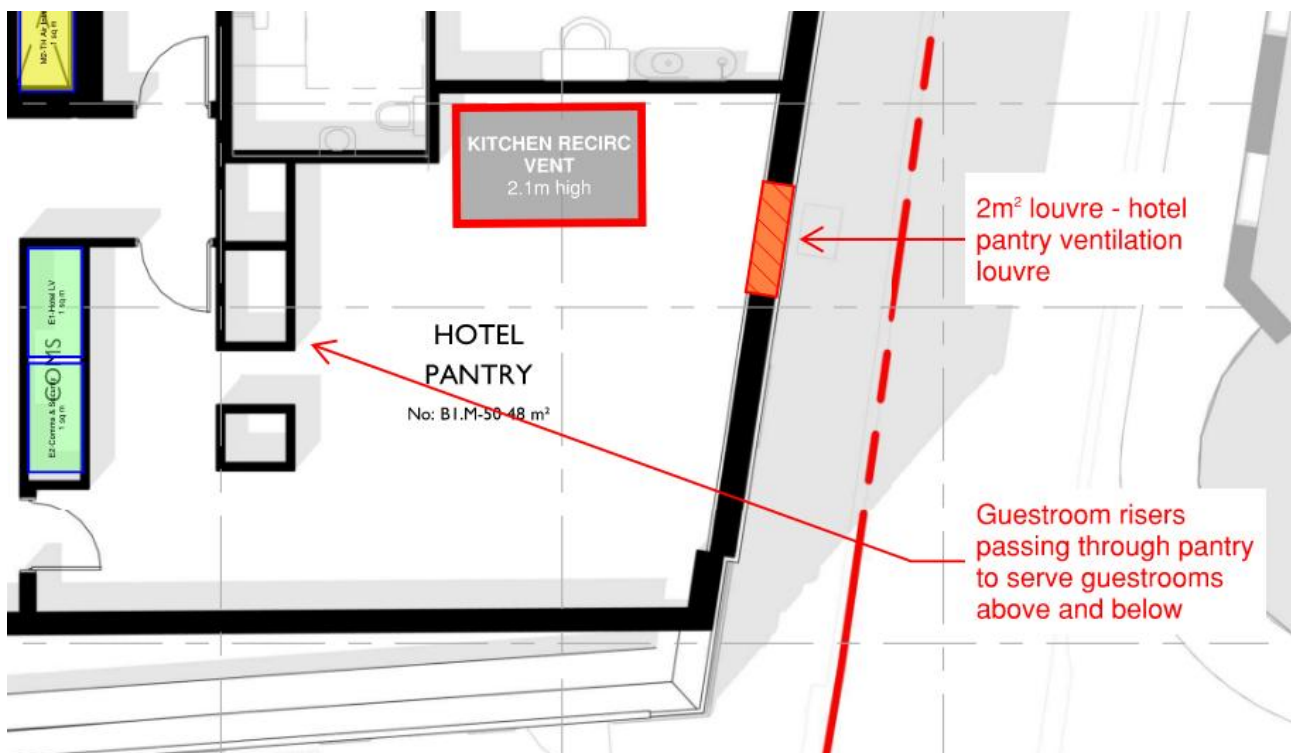

Figure 5 Typical hotel kitchen plant configuration



## 6. Appendix – Supporting information

Datasheet for the Halton RAH Recirculating Kitchen Extract System

# Halton

## Recirculating extract unit for commercial foodservice industry



Unlock new locations



Environmental benefits



Problem solving



Cost saving & flexibility



Enabling Wellbeing

Form#: BR-018  
Reco-Air by Halton Recirculating Units  
Rev: 03-2023



**Halton**

# No requirement for ductwork to exterior

RAH units work at the heart of a kitchen ventilation system serving all **electric catering equipment** and achieving complete recirculation of exhaust air with no requirement for route to atmosphere.

Highly efficient filter technology removes particulates and odors and provides exhaust air independently certified as clean to re-introduce as supply air.

Simplify planning procedures and providing opportunities to install kitchen operations in previously unfeasible locations.

## Reco-Air units prepares the exhaust air to be recirculated by removing grease, smoke and odor.



Grease



Smoke



Odor

### ✓ Cost effective

- RAH unit reduce CAPEX investment. They eliminate the costly fire-rated duct work to atmosphere thus reducing the construction costs. They also reduce installation costs as well as utility usage with a compact design and an ease of assembly.
- Traditional extract duct work requires regular specialist cleaning and accessing duct systems is often difficult and costly.
- When combined with Halton's Capture Jet™ hoods or ventilated ceiling, the installation and operating costs are even more reduced. The operating costs reach the lowest possible level when M.A.R.V.E.L. optimization airflow technology is also used.
- RAH units are a cost efficient alternative to traditional extract when there's no easy route to atmosphere.

### ✓ Emissions control

- The contaminants produced by catering kitchens and food preparation facilities are not any longer expelled to atmosphere contrary to traditional extract.

### ✓ Flexible locations

- RAH units can be located internally adjacent to or remote from the point of hood extraction. The unit can be hung within ceiling voids giving flexibility to equipment layout and also eliminating the requirement for certain planning processes.
- RAH units are easily retro-fitted or relocated.

### ✓ Approvals

- UL 710B
- CE Certification



# Remove cooking effluent safely and save installation cost over ducted systems.



## Space Design Considerations

Space ventilation (minimum supply of fresh air) shall comply with local regulations based on cooking equipment installed. Space shall have adequate ventilation with minimum exhaust airflow 10% of RAH design airflow.

RAH is a recirculating system with heat from cooking equipment released back to space. Additional space cooling should be required.

Cooling capacity required (sensible heat only)

	Tons
RAH.1.0	2
RAH 1.5	2.6
RAH 2.0	3.9

Consult with your mechanical engineer on the most effective way to address this additional load.

## Save on installation and operation with the Capture Jet™ technology

The Capture Jet™ technology, used on Halton's hoods, enables reducing the exhaust airflow rates by up to 40% and even 50% with low proximity hoods.

Can you afford not to reduce the size of Reco-Air unit accordingly? What to say about the reduction of the ducts section, the installation time, the noise of operation and drafts, the energy consumption for the fans and also the space-saving in the plant room and in the ceiling voids? It is really question of a perfect match between savings and comfort.



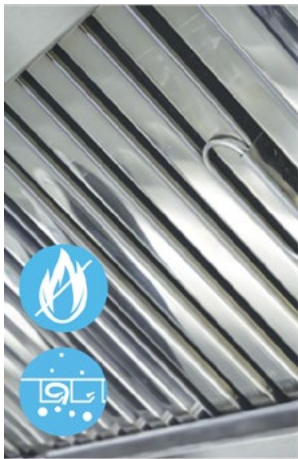

## Increased operation savings thanks to longer lifetime for the filters

The Capture Jet™ hoods are equipped with high efficiency KSA cyclonic filters. They remove up to 95% of the 10 microns particles. The combination with mesh filters globally increases KSA filters' efficiency.

What is captured by the easy to clean primary filters does not have any longer to be captured by Reco-Air unit's filters. Their lifetimes are increased leading to savings on operation.



## Limited heat transfer, minimum leakage and built to be fire stable

Reco-Air unit's structure is made of welded steel double wall panels insulated with .20lb/in<sup>3</sup> density mineral wool. This not only makes the unit, in the unlikely event of fire, stable but also limits the heat and odor transfer to the plant room on normal operation. It also mitigates sound from the unit.

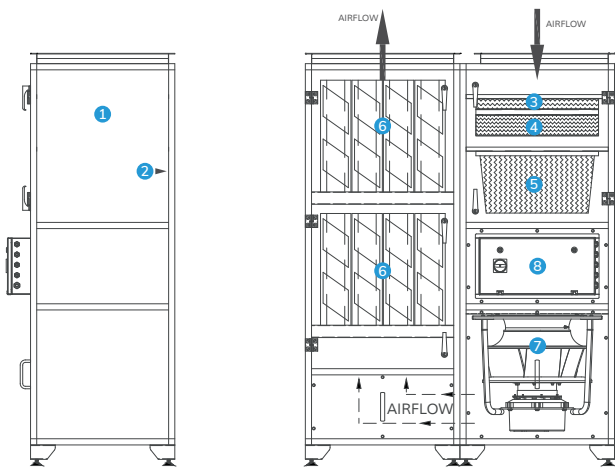

## CODE DESCRIPTION

- 1 1" double skin panel, .20 lb/cubic inch density mineral wool insulation
- 2 Galvanized steel finish to interior
- 3 Large grease particle removal MERV 8
- 4 Fine grease particle removal MERV 11
- 5 Smoke removal MERV 16
- 6 Coconut Shell activated carbon Cylinders - Odor removal minimum dwell time shall be 0.2 seconds.
- 7 EC Plug Fan, 208/460/3/60hz, suitable for 0-10v signal control
- 8 Control Box

**Note:** When used with an Electric broiler, the following changes to the filter arrangement are made:

- Replace the V-Bank MERV 16 final filter with a 99.97% HEPA filter
- Adjust static pressure for HEPA
- Use best practice for room air change strategy

\* Hoods must contain Mesh 2nd filter

## RecoAir Units Standard Specification

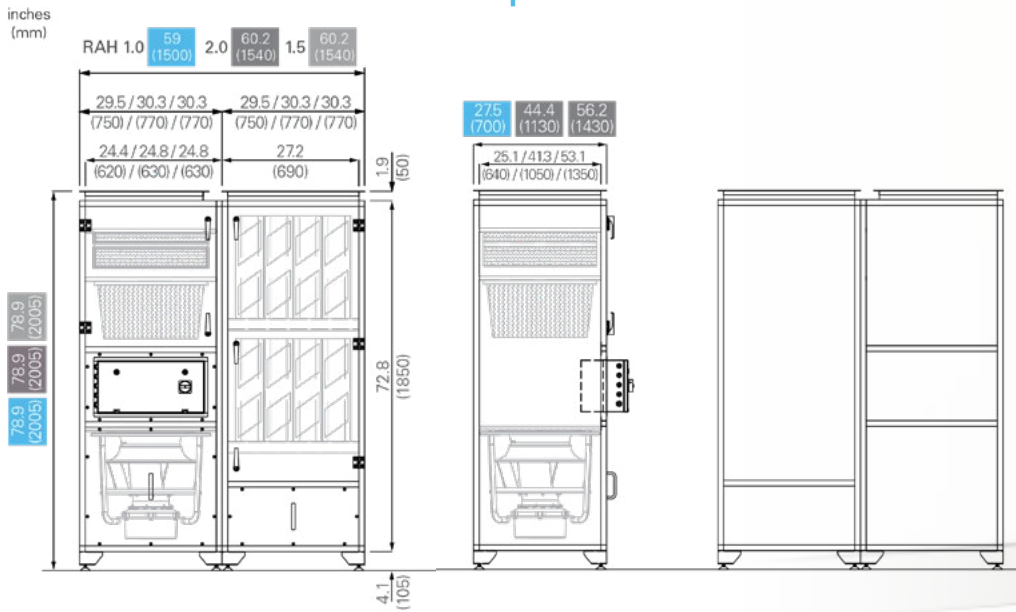

- 1" double skin panels
- Galvanized steel finish to interior
- Powder coat, baked enamel finish
- Panels insulated with .20lb/in<sup>3</sup> density mineral wool
- Primary Filters sets F1, F2, F3
- Fan section 208/460/3/60htz
- Three phase suitable for 0 to 10V signal control
- Unit duty Up to 3800 cfm @ 1.3" s.p.
- Motor full load on maximum speed 8.4amps at 460V, 16A @ 208V
- Max. working temperature range 140°F (60°C)
- F4 Activated carbon cylinders

	CFM	Static Pressure	Fan Size (in)	Amps	Max Hood Length* (in)	Unit dimensions and weight													
						Floor Mounted Size						Void Mounted Size						Weight (lbs)	
						W	D	H	Weight (lbs)	W	L	H	Weight (lbs)						
RAH.1.0	1900	1.0"	17	8	112"	59	1500	29	737	78.9	2005	1197	27.5	700	141	3581	34.5	876	1360
RAH 1.5	2550	1.3"	17	8	153"	60.2	1540	44.5	1130	78.9	2005	1662	44.4	1130	141	3581	36.25	921	1892
RAH 2.0	3800	1.3"	17	8	228"	60.2	1540	56.2	1429	78.9	2005	1980	56.2	1430	141	3581	36.25	921	2251

(\*) Max hood length typically connected to the unit

## Acoustic survey report by Applied Acoustic Design

RAH noise levels are very low. Casing-radiated noise from standard units are between 53 to 64 dBA when measured at 1m.



## ABOUT US

Halton Group is the global technology leader in indoor air solutions for demanding spaces. The company develops and provides solutions for commercial and public premises, healthcare institutions and laboratories, professional kitchens and restaurants as well as energy production environments and marine vessels. Halton's mission is to provide its end-users with safe, comfortable, and productive indoor environments that are energy-efficient and comply with sustainable principles.

### **Halton Company**

101 Industrial Drive  
Scottsville, KY 42164, USA  
Tel: (270) 237-5600

### **Halton Indoor Climate Systems**

1021 Brevik Place  
Mississauga, ON L4W 3R7, Canada  
Tel: (905) 624-0301

### **Halton Global Services**

1750 Valley View Ln, Ste. 100  
Farmers Branch, TX 75234, USA  
Tel: (972) 419-5100

[www.halton.com](http://www.halton.com)



**MARK WILLIS**  
SENIOR ASSOCIATE

+44 1454 806 835  
markwillis@hoarelea.com

HOARELEA.COM

155 Aztec West  
Almondsbury  
Bristol  
BS32 4UB  
England

