

This drawing is protected under Copyright and at no time should any portion of this drawing be reproduced or copied without the permission of the Architect (Design Copyright Act 1968).  
 This drawing must not be used for purposes other than that for which it was provided. It is supplied without liability for any errors or omissions.  
 Drawings only to be scaled for planning application purposes, all dimensions to be checked on site. All drawings subject to Statutory Authority Approval.

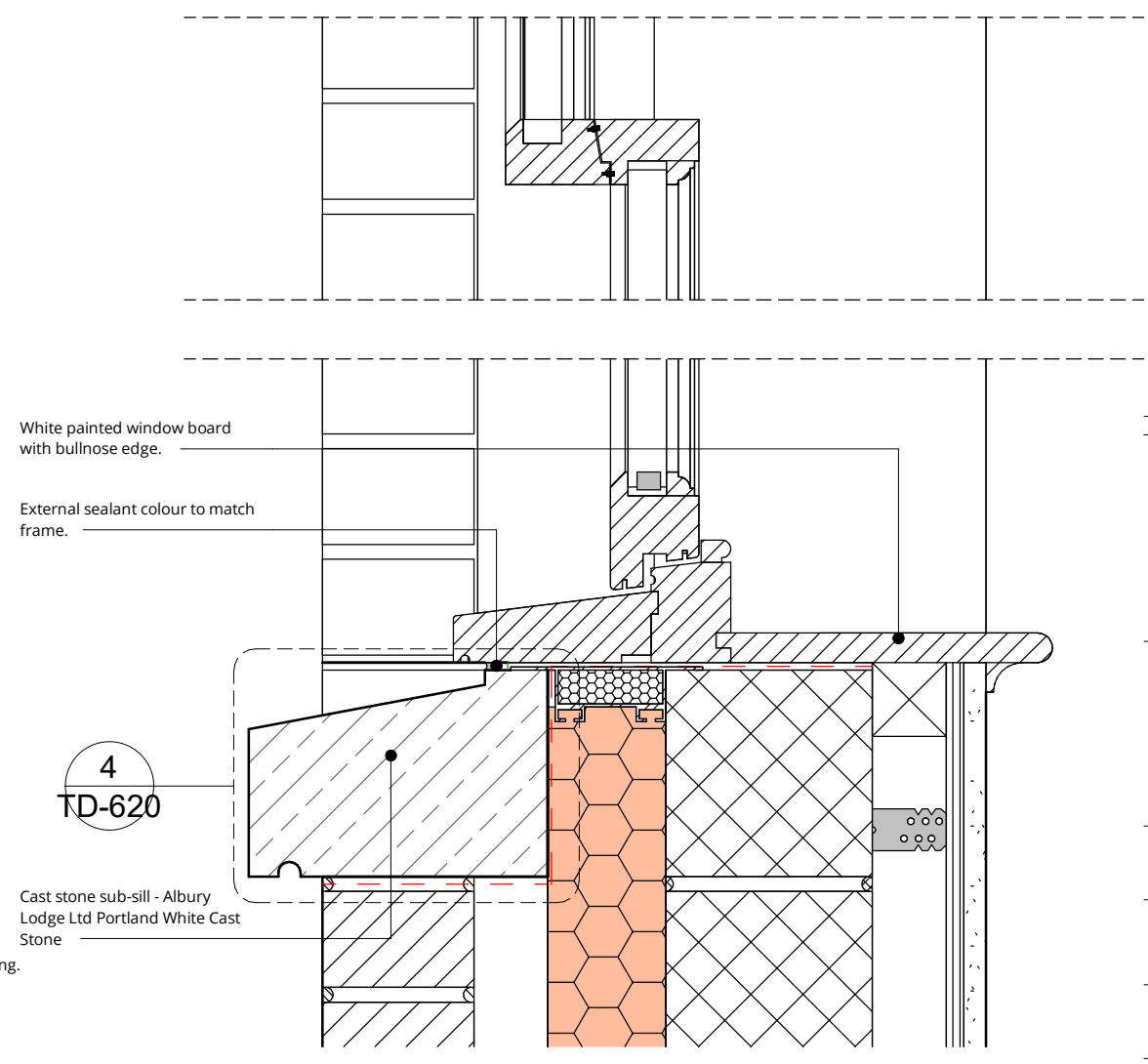

A	Tender Update	29.09.23
0	Tender Issue	22.09.23
Rev	Description	Date

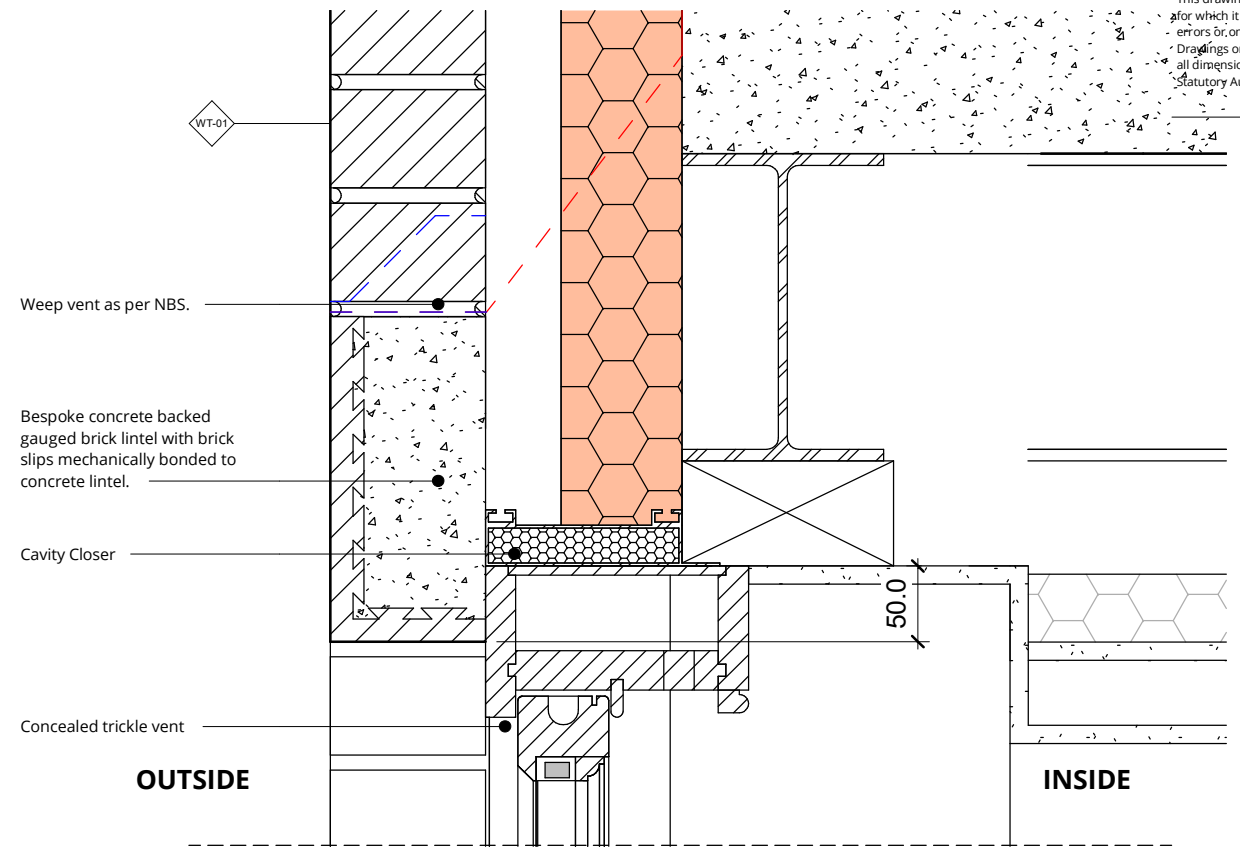
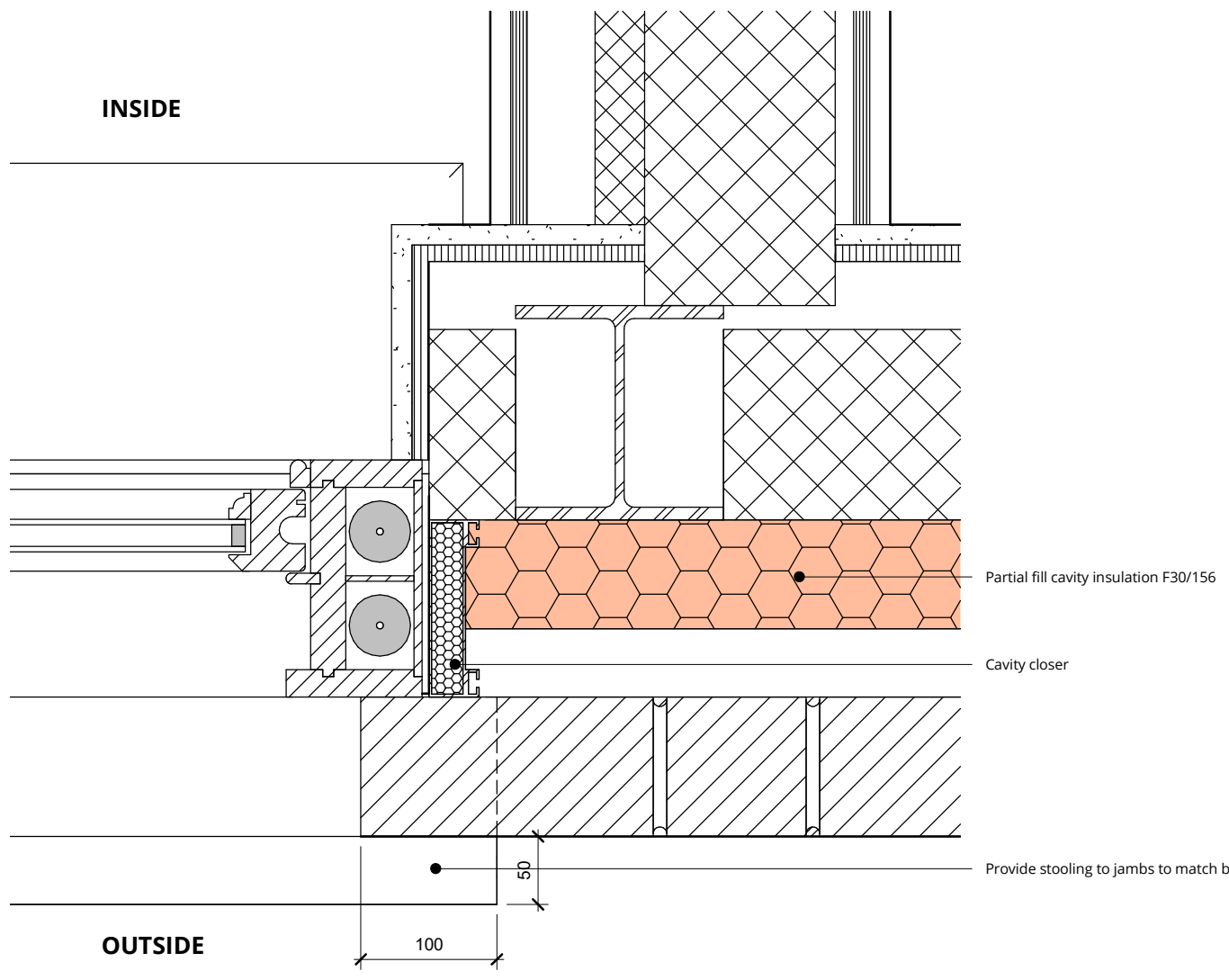
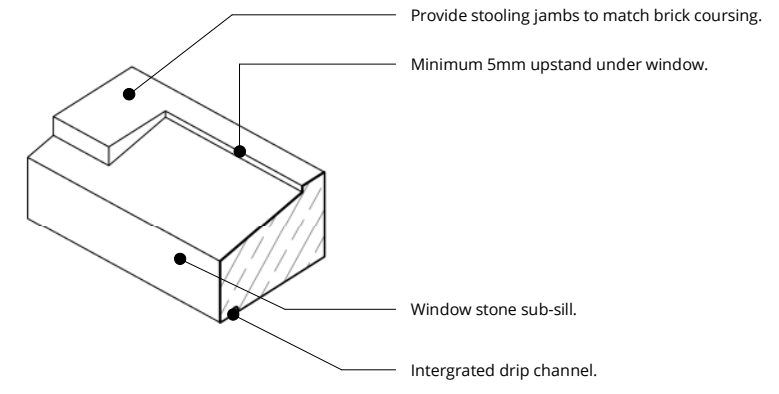
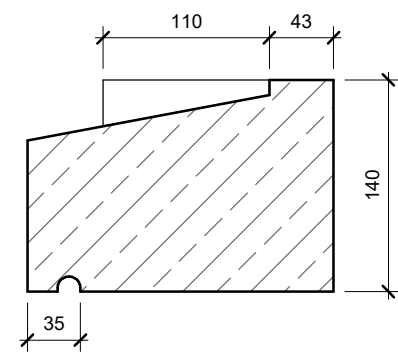

16 lambton place  
 notting hill  
 london w11 2sh  
 t 02072293125  
 f 02072293257  
 e info@wolffarchitects.co.uk  
 status:

**TENDER**

project:  
**7 Redington Gardens  
 London NW3 7RU**

drawing title:  
**Typical Window Detail**

date: <b>09/06/23</b>	scale: <b>1:5</b>
dwg no: <b>2252-TD-620</b>	rev no: <b>A</b>