

JAMB: TIMBER
 HINGE: BUTT
 WALL SKIRTING: DIES INTO ARCHITRAVE
 DOOR SKIRTING: NONE
 PLASTERBOARD EDGE: NONE
 NBS SPECIFICATION: L20:414 L20:415
 100

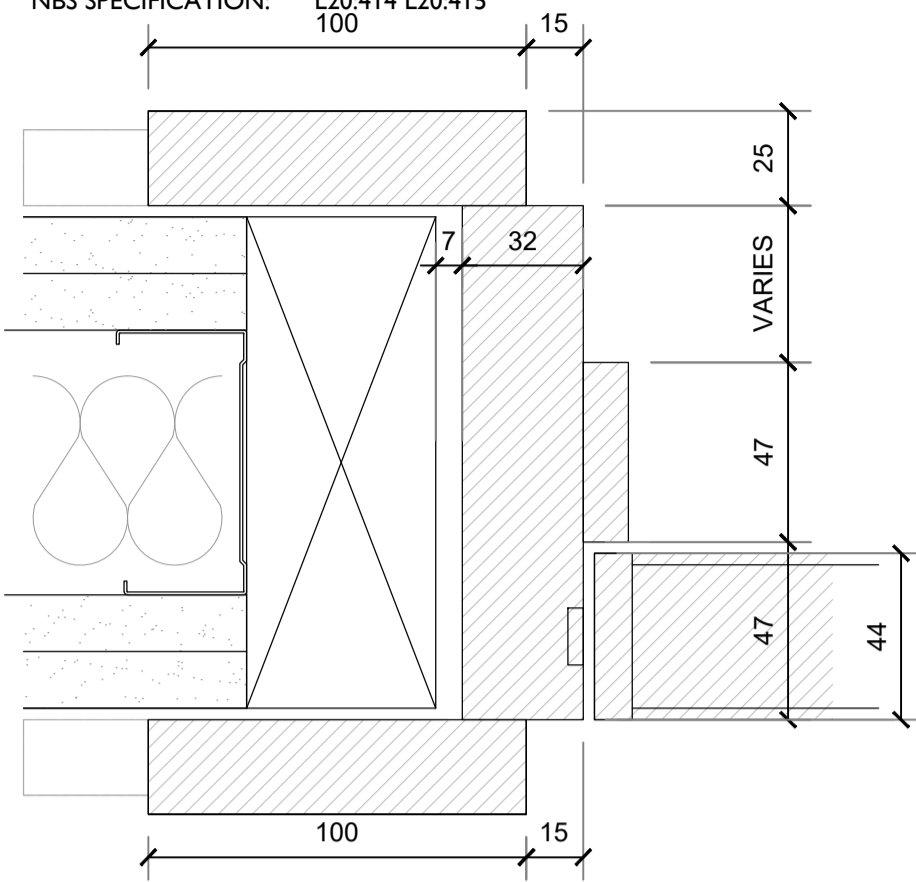

O JAMB DETAIL O
 1:2

GLAZING BEAD DETAIL

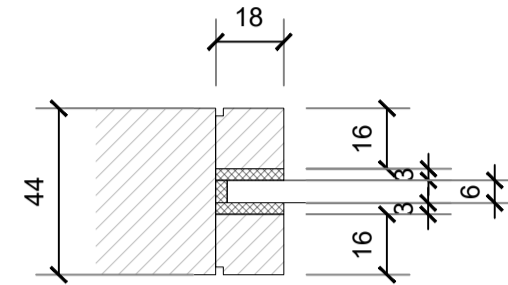

1 GLAZING BEAD DETAIL
 1:2

JAMB: TIMBER WITH ACOUSTIC SEALS
 HINGE: BUTT
 WALL SKIRTING: DIES INTO ARCHITRAVE
 DOOR SKIRTING: NONE
 PLASTERBOARD EDGE: NONE
 NBS SPECIFICATION: L20:411 L20:412
 100

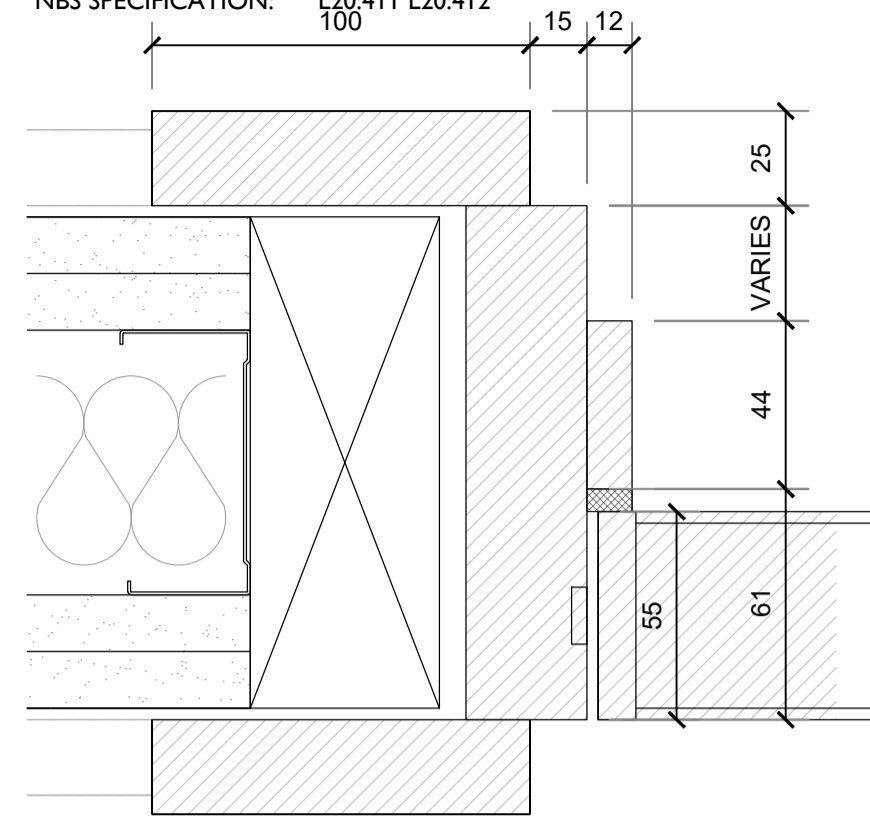

P JAMB DETAIL P
 1:2

JAMB: EZYJAMB
 HINGE: BUTT
 WALL SKIRTING: NONE
 DOOR SKIRTING: NONE
 PLASTERBOARD EDGE: EZYJAMB
 NBS SPECIFICATION: L20:417

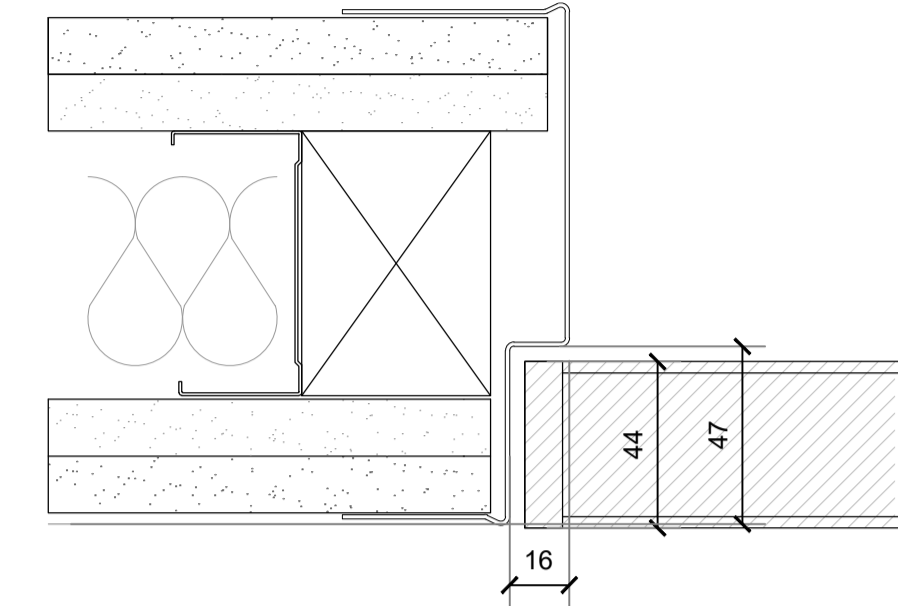

Q JAMB DETAIL Q
 1:2

JAMB: TIMBER
 HINGE: BUTT
 WALL SKIRTING: DIES INTO PLINTH BLOCK
 DOOR SKIRTING: NONE
 PLASTERBOARD EDGE: NONE
 NBS SPECIFICATION: L20:277

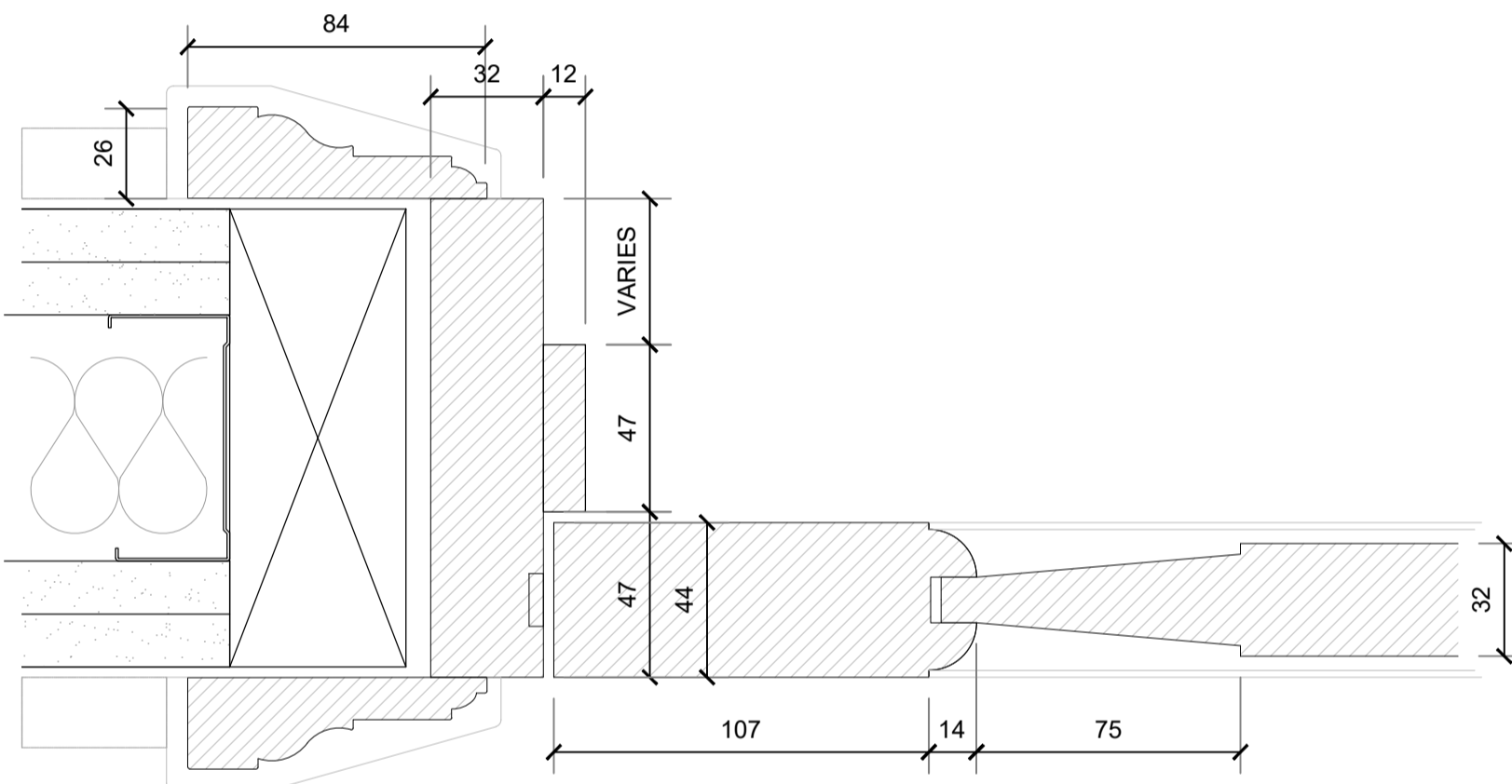

R JAMB DETAIL R
 1:2

JAMB: STAINLESS STEEL
 HINGE: BUTT
 WALL SKIRTING: DIES FRAME
 DOOR SKIRTING: NONE
 PLASTERBOARD EDGE: NONE
 NBS SPECIFICATION: L20:413

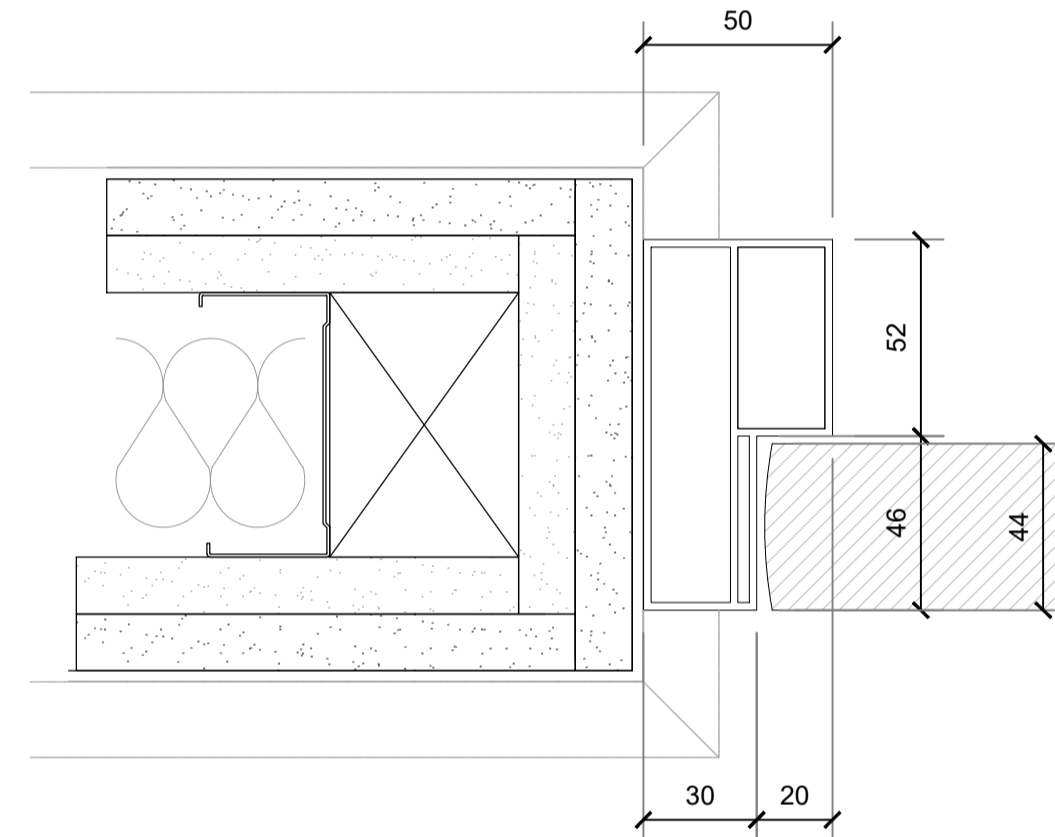

S JAMB DETAIL S
 1:2

Notes:

Drawings are based on survey data and may not accurately represent what is physically present.

Do not scale from this drawing. All dimensions are to be verified on site before proceeding with the work.

All dimensions are in millimetres unless noted otherwise.

Purcell shall be notified in writing of any discrepancies.

Key Plan
 not to scale

REV	DATE	BY	CHK	DESCRIPTION
C01	14.06.2024	ML	NS	First Issue

CLIENT
Il Bottaccio
 PROJECT
Camden Town Hall Tenant Fitout

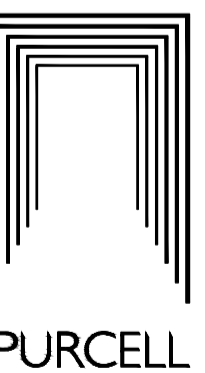

JOB NUMBER
242931

TITLE
DOOR DETAILS PART 3

SIZE SCALE
 A1L 1:5

REV SUITABILITY/REASON FOR ISSUE
C01 A4 - TECHNICAL DESIGN APPROVAL

DRAWING NUMBER
242931-PUR-01-XX-DR-A-6702

PURCELL® IS THE REGISTERED TRADE NAME FOR PURCELL ARCHITECTURE LTD AND ALL SUBSIDIARY COMPANIES AND IS REGISTERED IN THE UNITED KINGDOM, EUROPEAN UNION, HONG KONG, CHINA AND AUSTRALIA. © PURCELL 2024. www.purcell.com