

AOYG18KBTB

Please visit our [webstore](#) for full product and technical documentation 

Nominal Cooling Capacity	(kW)	5.2
Nominal Heating Capacity	(kW)	6.0
Height	(mm)	632
Width	(mm)	799
Depth	(mm)	290
Weight	(kg)	36
Airflow Rate - Cooling - High	(m3/h)	2160
Airflow Rate - Heating - High	(m3/h)	1830
Sound Pressure Level - Cooling - High	(dB(A))	50
Sound Pressure Level - Heating - High	(dB(A))	50
Sound Power Level - Cooling - High	(dB(A))	62
Sound Power Level - Heating - High	(dB(A))	62
Refrigerant Type (Global Warming Potential)		R32 (675)
Liquid Pipe Size		1/4"
Gas Pipe Size		1/2"
Min - Max Pipe Length	(m)	3 - 30
Max Height Difference	(m)	20
Refrigerant Charge (kg)	(kg)	1.02
Refrigerant CO2eq-T		0.689
Precharged For	(m)	20
Additional Charge (g/m)	(g/m)	20
Unit Power Supply		1Ph-230V-50Hz
Suggested Fuse Size	(A)	16
Cooling Mode Minimum Ambient	(°C)	-15
Cooling Mode Maximum Ambient	(°C)	46
Heating Mode Minimum Ambient	(°C)	-15
Heating Mode Maximum Ambient	(°C)	24

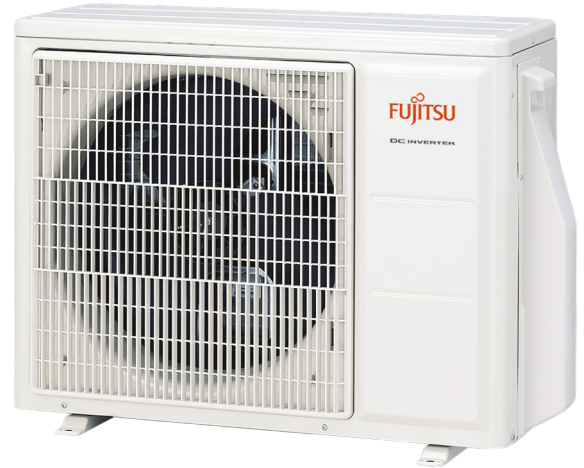

Document Downloads

[Accessories](#)

[Airflow](#)

[Capacity Correction](#)

[Charging Details](#)

[Controls & Accessories](#)

[Dimensional Drawing](#)

[Electrical Characteristics](#)

[Installation Manual](#)

[Installation Space](#)

[Noise Curve](#)

[Product Image](#)

[Refrigerant Circuit](#)

[Spare Parts List All Pages](#)

[Specifications](#)

[Wiring Diagram](#)

Related Items

[AUXG18KVLA](#)

5.2kW Compact Cassette Indoor Unit - R32

[AUXG18KRLB](#)

5.2kW Circular Flow Cassette Indoor Unit - R32

[ARXG18KLLAP](#)

5.2kW Slim Ducted Indoor Unit - R32

[ARXG18KHTAP](#)

5.2kW Medium - Hi Static Ducted Indoor Unit - R32

[ABYG18KRTA](#)

5.2kW Ceiling Suspended Indoor Unit - R32

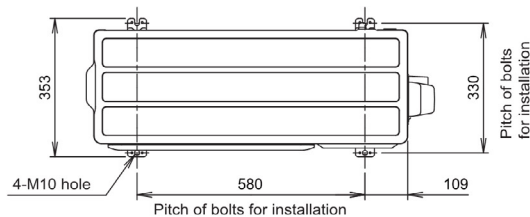

Top view

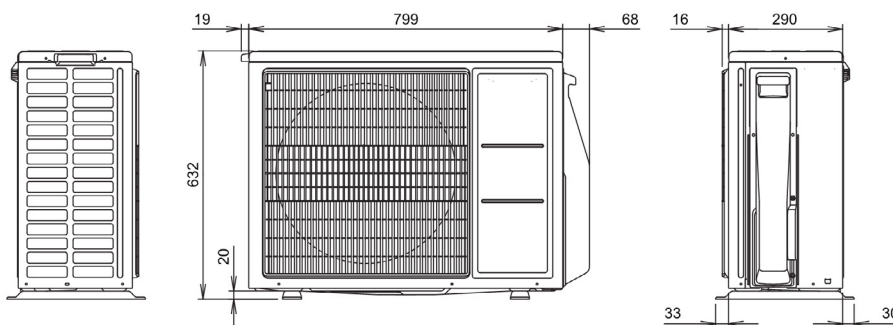

Side view

Front view

Side view

Units: mm

*Specifications and design are subject to change without notice for further improvement.

*Actual products' colors may be different from the colors shown in this printed material.