



Noise Impact Assessment

Client: Steve Mardon

Site: 5a Agar Place, London, NW1 0RG

Reference: 2811243NR

Revision: 0

Issued: 18/12/2024

Project Consultant

T. Brown BSc (Hons) MIOA
Acoustic Consultant
tom@acousticsurveys.co.uk

Executive Summary

A Noise Impact Assessment has been undertaken at 5a Agar Place, London in relation to the proposed installation of an ASHP unit.

Measurements of the background noise climate have been undertaken from 16th – 17th December 2024 at a position deemed representative of the identified Noise Sensitive Receptors (NSRs).

The nearest or most-affected Noise Sensitive Receptor has been identified as the rear of 2a Agar Place.

A BS4142:2014 Initial Impact Assessment of the predicted night-time noise impact indicated the potential for a 'Low Impact' at the NSR location, with Rating Levels 4dB below the representative night-time background sound level.

A further Contextual Assessment has been undertaken where noise levels from the site have been assessed to the existing noise climate along with other relevant factors and no further mitigation is deemed necessary as a Low Impact is indicated, corresponding to achievement 'NOEL – No Observed Effect Level' in the NPSE.

Contents

EXECUTIVE SUMMARY 2

Contents 3

Tables 4

Figures 4

1. INTRODUCTION 5

Overview 5

Scope & Objectives 5

2. ENVIRONMENTAL NOISE SURVEY 6

Measurement Methodology 6

Site Description 7

Context and Subjective Noise Climate 8

Non-Representative Noise Sources 9

Noise Sensitive Receptors 9

3. ENVIRONMENTAL NOISE SURVEY RESULTS 9

Measurement Results 9

4. BS4142:2014 INITIAL IMPACT ASSESSMENT 10

Noise Modelling 10

Source Noise Levels 10

Specific Sound Levels 11

Rating Levels 11

Rating Levels Vs Background 12

5. BS4142:2014 CONTEXTUAL ASSESSMENT 13

Aspects of absolute level 13

Aspects of character 13

Aspects of the receptor 13

Contextual recommendations 14

6. CONCLUSION 14

7. UNCERTAINTY 14

APPENDIX A - MEASUREMENT DETAILS 15

APPENDIX B - EQUIPMENT DETAILS 15

APPENDIX C - CALIBRATION DETAILS 15

APPENDIX D - METEOROLOGY DETAILS 16

APPENDIX E - NOISE SURVEY RESULTS 17

APPENDIX F - GRID NOISE MAPS 18

APPENDIX G - MANUFACTURER TECHNICAL DATA SHEETS 19

APPENDIX H - SITE PLANS 20

APPENDIX I - LEGISLATION, POLICY & GUIDANCE 21

BS4142:2014+A1:2019 22

BS8233:2014 23

APPENDIX J - ACOUSTIC TERMINOLOGY 24

Tables

TABLE 1: SUBJECTIVE SUMMARY OF NOISE SOURCES 8

TABLE 2: M1 BACKGROUND NOISE SURVEY RESULTS 9

TABLE 3: CALCULATION INPUT PARAMETERS 10

TABLE 4: ASHP NOISE LEVELS 11

TABLE 5: MODELLED SOURCE NOISE LEVELS 11

TABLE 6: SPECIFIC SOUND LEVELS 11

TABLE 7: RATING LEVELS 12

TABLE 8: NOISE IMPACT 13

TABLE 9: MEASUREMENT DATES 15

TABLE 10: MEASUREMENT EQUIPMENT DETAILS 15

TABLE 11: CALIBRATION DETAILS 15

Figures

FIGURE 1: SITE, SOURCE & NSR LOCATIONS - [HTTPS://GOOGLE.CO.UK/MAPS](https://google.co.uk/maps) 7

FIGURE 2: M1 BACKGROUND STATISTICAL ANALYSIS 9

FIGURE 3: SITE LOCATION MEASUREMENT PICTURES 15

FIGURE 4: METEOROLOGY DATA - [HTTPS://WWW.TIMEANDDATE.COM/WEATHER](https://www.timeanddate.com/weather) 16

FIGURE 5: MEASURED BACKGROUND SOUND LEVELS TIME HISTORY (M1): 16TH – 17TH DECEMBER 2024 17

FIGURE 6: 3D NOISE MAP OF NIGHT-TIME INITIAL IMPACT ASSESSMENT 18

FIGURE 7: DATA SOURCED FROM GRANT UK DATA SHEET 19

FIGURE 8: SITE PLANS PROVIDED BY 'A MITCHELL ARCHITECTS'¹ 20

1. Introduction

Overview

A Noise Impact Assessment has been undertaken at 5a Agar Place, London for the proposed installation of an air source heat pump.

Details of the proposed unit have been provided by the applicant:

- Grant Aerona HPID10R32

Manufacturers technical specifications with noise level data for the unit have been sourced and are given in **Appendix G**.

The unit will be installed on the southeast façade at 2nd floor level within a balcony area below wall height.

An assessment of the proposed plant equipment is to be undertaken to determine whether residents are likely to suffer a loss of amenity as a result of noise from the ASHP. Mitigation will be given should any potential loss of amenity be indicated.

Scope & Objectives

The scope of the noise assessment can be summarised as follows:

- Baseline sound monitoring survey to evaluate the prevailing background sound levels at the Noise Sensitive Receptor ('NSR') in accordance with BS7445 - '*Description and Measurement of Environmental Noise*';
- Detailed sound modelling, acoustic calculations and analysis to predict sound levels at the NSR using industry-standard acoustic modelling software 'SoundPLAN'. This software uses ISO-9613-2 - *Attenuation of sound during propagation outdoors*;
- A contextual assessment for the suitability of the site, in accordance with relevant standards in respect of sound from the proposed sources; and
- Recommendation of mitigation measures where necessary, to comply with the requirements of the National Planning Policy Framework (2021), Noise Policy for England (2010) and British Standard BS 4142:2014+A1:2019 – Methods for rating and assessing industrial and commercial sound.
- No local policy guidance or comments have been provided in relation to the assessment.
- Further information on the legislation can be found in **Appendix I**.

2. Environmental Noise Survey

Measurement Methodology

To establish the existing environmental noise levels on site, a noise survey was conducted from the 16th – 17th December 2024. Measurements of $L_{Aeq,T}$ and $L_{A90,T}$ were logged in 5-minute intervals in accordance with BS7445 - 'Description and Measurement of Environmental Noise'.

The unattended monitoring location (M1) was positioned out of a 1st floor rear window at a height of approximately 4.5 metres.

The monitoring position is deemed representative of sound levels at 'NSR 1' during the typical operational periods of the proposed development.

Further detail of the measurement along with site pictures is given in **Appendix A**.

Measurements were obtained using Class 1 instrumentation. Full equipment details are given in **Appendix B**.

Equipment was calibrated before and after use and no significant drift occurred during measurements. Up-to-date calibration certification can be provided upon request. Full calibration details are provided in **Appendix C**.

A -3dB correction is applied to measured data to account for proximity to the building façade.

Daytime temperatures during the survey were noted as between 11 - 12°C with wind speeds typically between 3 - 4m/s; deemed suitable for conducting environmental noise monitoring. Detailed meteorological information can be found in **Appendix D**.

The site, proposed noise source and NSR locations are shown in **Figure 1**.

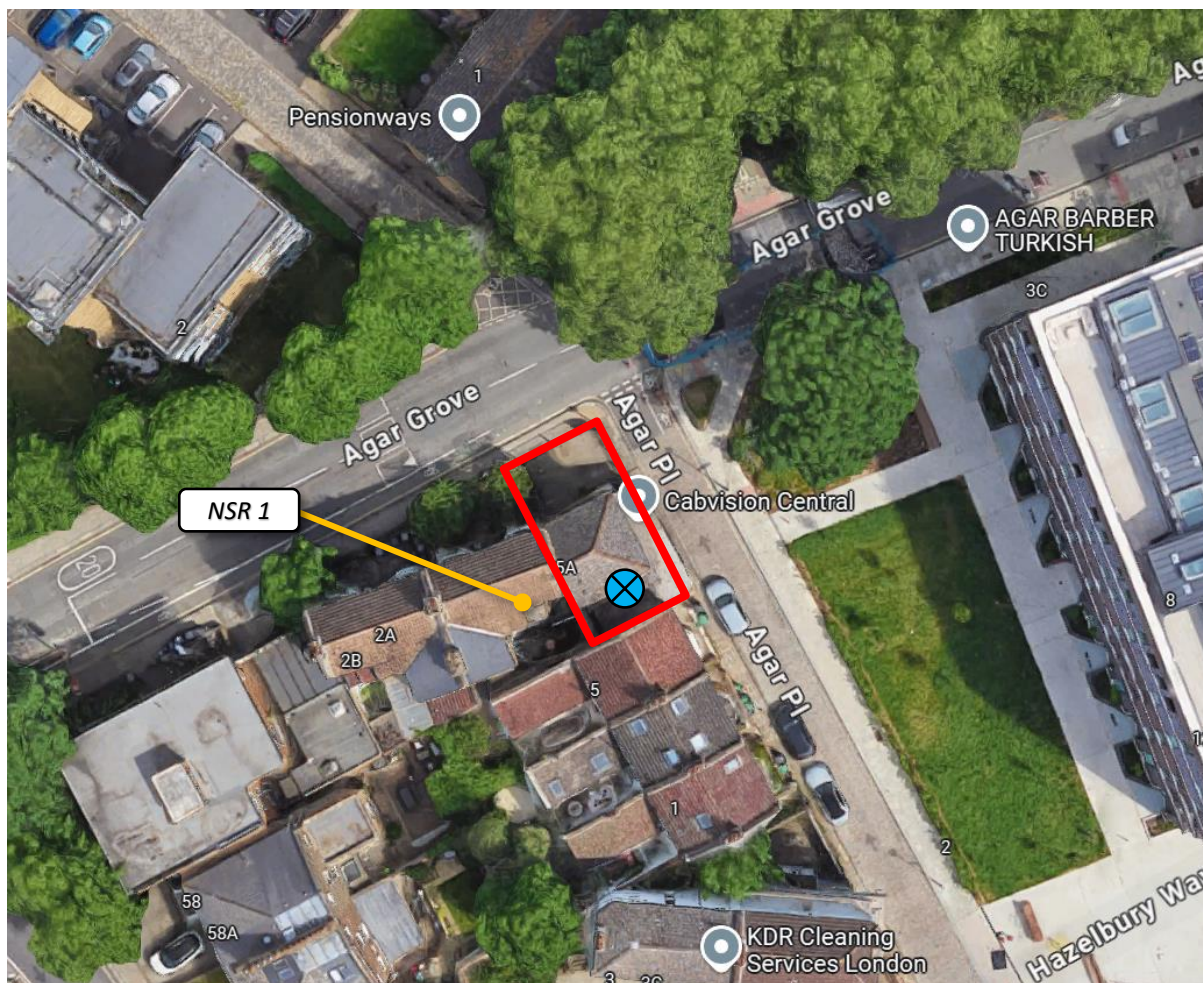





Figure 1: Site, Source & NSR Locations - <https://google.co.uk/maps>

-  Site Boundary
-  ASHP Location
-  Noise Sensitive Receptor (NSR)
-  Background Monitoring Location M1 and proposed ASHP location

Site Description

The site is located at the corner of Agar Place and Agar Grove in central London. The ground floor of the site is a small taxi workshop while the upper floors are residential. The surrounding area is predominantly residential with dwellings adjacent to the south and west of the site and blocks of flats to the north and east. Further to the south is an elevated section of railway line.

At the time of measurement a traffic diversion was in place for Agar Grove with temporary traffic lights in place. This is likely to have given lower than normal background noise level readings for the area.

Context and Subjective Noise Climate





Noise Source	Description	Time of Observation	Photo
Road	Light road noise from cars, vans, motorbikes etc passing the site	Intermittent during site visits	
Pedestrians	Pedestrians including dog walkers passing the site	Intermittent during site visits	
Construction Noise	Construction noise on nearby site, petrol tools in use	Intermittent during site visits	
Taxi Workshop	Ground floor of site, workshop fitting equipment to taxi's. Power tools in use	Occasional during site visits	

Table 1: Subjective Summary of Noise Sources

Non-Representative Noise Sources

During the survey, no noise events occurred which would be deemed as atypical of the site location.

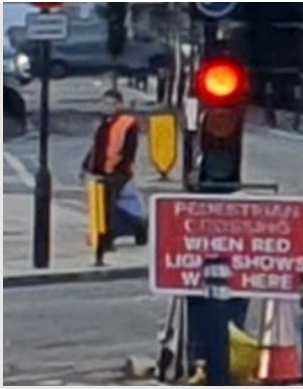
Noise Sensitive Receptors

The nearest or most-affected Noise Sensitive Receptor (NSR) has been identified as the rear façade of 2b Agar Place. The closest habitable room windows will be considered as specific reception points in calculations.

3. Environmental Noise Survey Results

Measurement Results

The ASHP will serve 1st and 2nd floor accommodation of the site and therefore has the potential to operate at any time of the day or night.

The day and night-time background sound levels from measurement M1 are summarised below:

Measurement	Date(s)	Period	L _{Aeq,T}	L _{A90,T}
M1	16 th & 17 th December 2024	Daytime (07:00 – 23:00)	47	41
	16 th – 17 th December 2024	Night-time (23:00 – 07:00)	43	35

Table 2: M1 Background Noise Survey Results

A full-time history of the survey data is shown in **Appendix E**.

For the derivation of a representative night-time background sound level, data from the whole night-time period (23:00 – 07:00) has been statistically analysed.

A graph of the statistical analysis for M1 night-time data is given below:

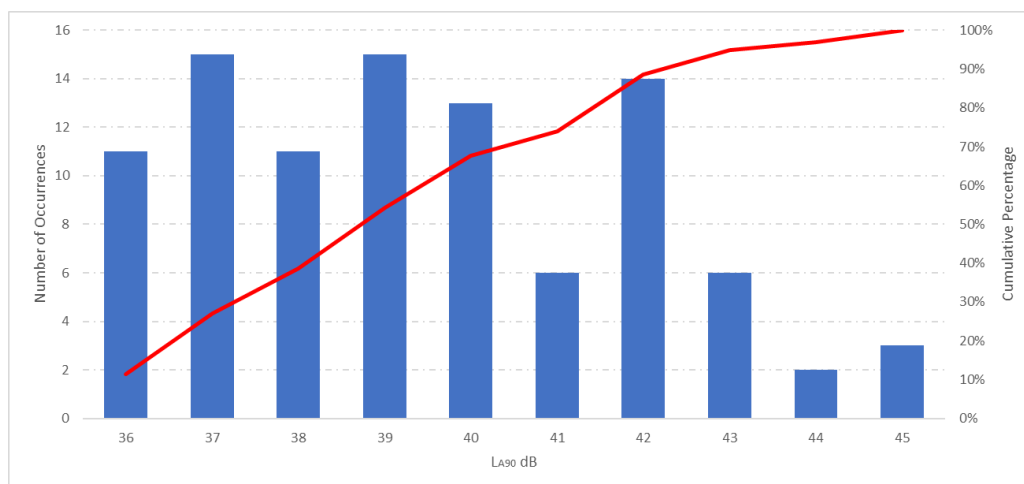

Figure 2: M1 Background Statistical Analysis

From the statistical analysis of M1 measurement and taking into account the -3dB correction from section 2, **35dB L_{A90}** has been selected as the representative background sound level for the BS4142:2014 assessment at the NSR locations.

4. BS4142:2014 Initial Impact Assessment

Noise Modelling

External sound propagation from the site has been calculated using industry-standard acoustic modelling software 'SoundPLAN'. This software uses ISO-9613-2 - *Attenuation of sound during propagation outdoors* and the model takes into account the following key factors:

- *Aerial Imagery & Terrain Data sourced from Google Maps/Elevations*
- *Geometric divergence of sound*
- *Atmospheric absorption of sound*
- *Ground absorption*
- *A light downwind correction toward the NSRs*
- *Surrounding structures and objects which may reflect or block sound toward the NSRs*
- *The height of the NSRs (i.e., First/second-floor reception point)*
- *Operational schedule of equipment*

The following input parameters were used in the noise model:

Parameter	Input
Reflection Order	3
Ground Absorption Factors	G = 0.3 (Mixed Ground)
Air pressure	1013.3 mbar
Relative Humidity	70.0 %
Temperature	10.0°C

Table 3: Calculation Input Parameters

Source Noise Levels

Details of the proposed ASHP have been provided by the applicant:

- 1 x Grant Aeron HPID10R32

Manufacturers technical specifications with noise level data have been sourced and are given in **Appendix G**.

The manufacturer provides only a single figure sound power level for the unit and so spectral data has been adapted from a similar unit to give the same overall output and will be used within the assessment:

Unit	Para.	63	125	250	500	1k	2k	4k	8k	dBA
Grant Aerona ASHP	Lw	64	66	68	62	57	53	49	50	64

Table 4: ASHP Noise Levels

Details of the noise sources that have been modelled in ‘SoundPLAN’ are given below.

Source No.	Source	Parameter	Noise Level, dBA	Height above Ground (m)
1	ASHP	LWA	64	7.5

Table 5: Modelled Source Noise Levels

To account for a worst-case scenario, the source will be modelled to be running at 100% for the entire 24 hours.

The noise model does not account for minor landscape features such as low garden walls and fences.

Specific Sound Levels

The Specific Sound Level is denoted L_{As} and is the A-weighted, equivalent noise level at the NSR locations. Specific Sound Levels have been calculated from the noise model and the levels at the worst affected floors of receptors are given below.

Location	Specific Sound Level, dB L_{As}
NSR 1 (2F)	28

Table 6: Specific Sound Levels

Rating Levels

In accordance with BS4142, the Specific Sound Levels may be corrected for characteristics that make the sound more noticeable at the NSR location such as tonality, impulsivity and intermittency. Section 9.2 of BS4142:2014 gives commentary on these characteristics and appropriate penalties:

“Tonality

For sound ranging from not tonal to prominently tonal the Joint Nordic Method gives a correction of between 0 dB and +6 dB for tonality. Subjectively, this can be converted to a penalty of 2 dB for a tone which is just perceptible at the noise receptor, 4 dB where it is clearly perceptible, and 6 dB where it is highly perceptible.

Impulsivity

A correction of up to +9 dB can be applied for sound that is highly impulsive, considering both the rapidity of the change in sound level and the overall change in sound level. Subjectively, this can be converted to a penalty of 3 dB for impulsivity which is just perceptible at the noise receptor, 6 dB where it is clearly perceptible, and 9 dB where it is highly perceptible.

Other sound characteristics

Where the specific sound features characteristics that are neither tonal nor impulsive,

though otherwise are readily distinctive against the residual acoustic environment, a penalty of 3 dB can be applied.

NOTE 2 Where tonal and impulsive characteristics are present in the specific sound within the same reference period then these two corrections can both be taken into account. If one feature is dominant then it might be appropriate to apply a single correction. Where both features are likely to affect perception and response, the corrections ought normally to be added in a linear fashion.

Intermittency

When the specific sound has identifiable on/off conditions, the specific sound level ought to be representative of the time period of length equal to the reference time interval which contains the greatest total amount of on time. This can necessitate measuring the specific sound over a number of shorter sampling periods that are in combination less than the reference time interval in total, and then calculating the specific sound level for the reference time interval allowing for time when the specific sound is not present. If the intermittency is readily distinctive against the residual acoustic environment, a penalty of 3 dB can be applied.”

Noise from air source heat pumps is generally broadband aerodynamic type noise from the movement of air through the fan of the unit. This is not considered to be tonal or impulsive and so no rating penalties will be applied in relation to these factors.

As the unit may operate intermittently to maintain a certain temperature within the site, a +3dB penalty will be applied for intermittency.

The resultant Rating Levels are summarised below:

Location	Specific Sound Level, dB L _{As}	Total BS4142 Character Corrections	Rating Level, dB L _{Ar}
NSR 1	28	+ 3	31

Table 7: Rating Levels

Rating Levels Vs Background

The Rating Levels are to be compared to the representative background sound level to determine the noise impact in accordance with BS4142.

A Sound Rating Level at or below the background noise level is indicative of Low Impact;

A Sound Rating Level that exceeds the background noise level by around +5dB is likely an indication of Adverse Impact, depending on the context;

A Sound Rating Level that exceeds the background noise level by around +10dB is likely an indication of Significant Adverse Impact, depending on the context;

The indicated noise impact at the identified Noise Sensitive Receptors is summarised below:

Location	Rating Level, dB L _{ar}	Background Sound Level, dB L _{A90}	Difference, dB	Noise Impact
NSR 1	31	35	- 4	Low

Table 8: Noise Impact

The noise impact at all receptor positions is indicative of a ‘Low Impact’ in accordance with BS4142:2014.

5. BS4142:2014 Contextual Assessment

Aspects of absolute level

Absolute levels on site with the ASHP operational have been calculated in ‘SoundPLAN’ to be 28 dBA (this is exclusive of any rating penalties), at NSR1. In comparison to the range of night-time background sound levels measured on site (33 – 42 dB L_{A90}) the absolute level is below the range of existing noise levels on site.

With context, it is possible that at times the unit will run at maximum capacity during the night depending on meteorological conditions, however it is more common that heating is turned down overnight making it less likely that the unit will run.

In considering the points above, the absolute sound level is deemed to be appropriate whilst considering a worst-case scenario but with context, the sound levels on site are potentially lower than modelled.

Aspects of character

The external plant equipment is assumed to be broadband in nature, with no tonal or impulsive characteristics. The external plant equipment serves to control temperatures within the site and therefore will operate when required in response to demand and meteorological conditions.

A +3 dB penalty for intermittency has been applied in the Initial Impact Assessment.

Aspects of the receptor

The NSR location is a residential property which is assumed to be accustomed to the current noise climate from the surrounding roads.

Taking guidance from BS8233:2014 for external amenity spaces, a desirable guideline of 50 dB L_{Aeq,16hr} and an acceptable guideline of 55 dB L_{Aeq,16hr} for noisier environments is deemed appropriate. Calculations from the Initial Impact Assessment display external noise levels at the NSRs well within the desirable guideline.

Guidance is also taken from ‘Appendix C’ of the ‘Acoustics Ventilation And Overheating: Residential Design Guide–January 2020’ to specify an outside-to-inside level difference of approximately 13 dB through an open window. When this is applied to the predicted night-time levels at the NSR location, internal levels within the dwellings would be within the guidelines of BS8233:2014.

Contextual recommendations

After analysis of the existing site use in conjunction with this proposal, no additional mitigation of the proposed ASHP unit is deemed necessary in order to achieve a 'Low Impact' in accordance with BS4142:2014.

6. Conclusion

A Noise Impact Assessment has been undertaken at 5a Agar Place, London in relation to the proposed installation of an ASHP unit.

Measurements of the background noise climate have been undertaken from 16th – 17th December 2024 at a position deemed representative of the identified Noise Sensitive Receptors (NSRs).

The nearest or most-affected Noise Sensitive Receptor has been identified as the rear of 2a Agar Place.

A BS4142:2014 Initial Impact Assessment of the predicted night-time noise impact indicated the potential for a 'Low Impact' at the NSR location, with Rating Levels 4dB below the representative night-time background sound level.

A further Contextual Assessment has been undertaken where noise levels from the site have been assessed to the existing noise climate along with other relevant factors and no further mitigation is deemed necessary as a Low Impact is indicated, corresponding to achievement 'NOEL – No Observed Effect Level' in the NPSE.

7. Uncertainty

The background monitoring equipment is subject to a 1dB error margin, however, calibration before and after measurements allows the drift within the margin to be monitored and thus demonstrates that minimal drift occurred throughout the measurements.

Uncertainty can arise in the prediction of noise propagation from and around flat reflective surfaces, such as the surrounding structures present on site. This has been reduced to a minimum by utilising an acoustic modelling software that uses the validated method, ISO-9613-2, as described in BS4142.

Uncertainty in the calculated specific sound levels is further reduced by utilising manufacturer-given sound power levels.

APPENDIX A - Measurement Details

Measurement	Kit	Start Date	Start Time	End Date	End Time
M1	A3	16/12/24	12:35	17/12/24	12:00

Table 9: Measurement Dates



Figure 3: Site Location Measurement Pictures

APPENDIX B - Equipment Details

Kit	Equipment	Make	Model	Class	Serial Number
A3	Sound Meter	Svantek	971	1	41980
A3	Pre-Amp	Svantek	SV18	1	44331
A3	Microphone	ACO	7052E	1	60249
2	Calibrator	Svantek	SV33	1	83715

Table 10: Measurement Equipment Details

APPENDIX C - Calibration Details

Measurement	Calibrator Ref Level (dB)	Deviation Before (dB)	Deviation After (dB)
M1	113.80	0.42	0.47

Table 11: Calibration Details

APPENDIX D - Meteorology Details

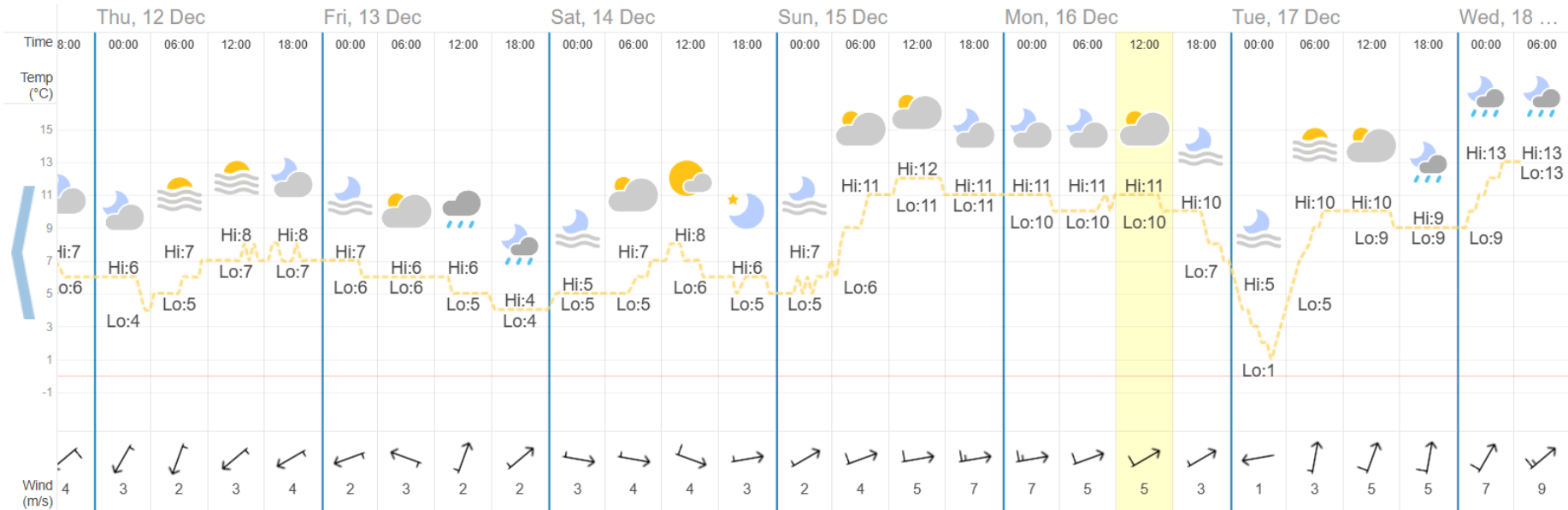

Figure 4: Meteorology Data - <https://www.timeanddate.com/weather>

APPENDIX E - Noise Survey Results

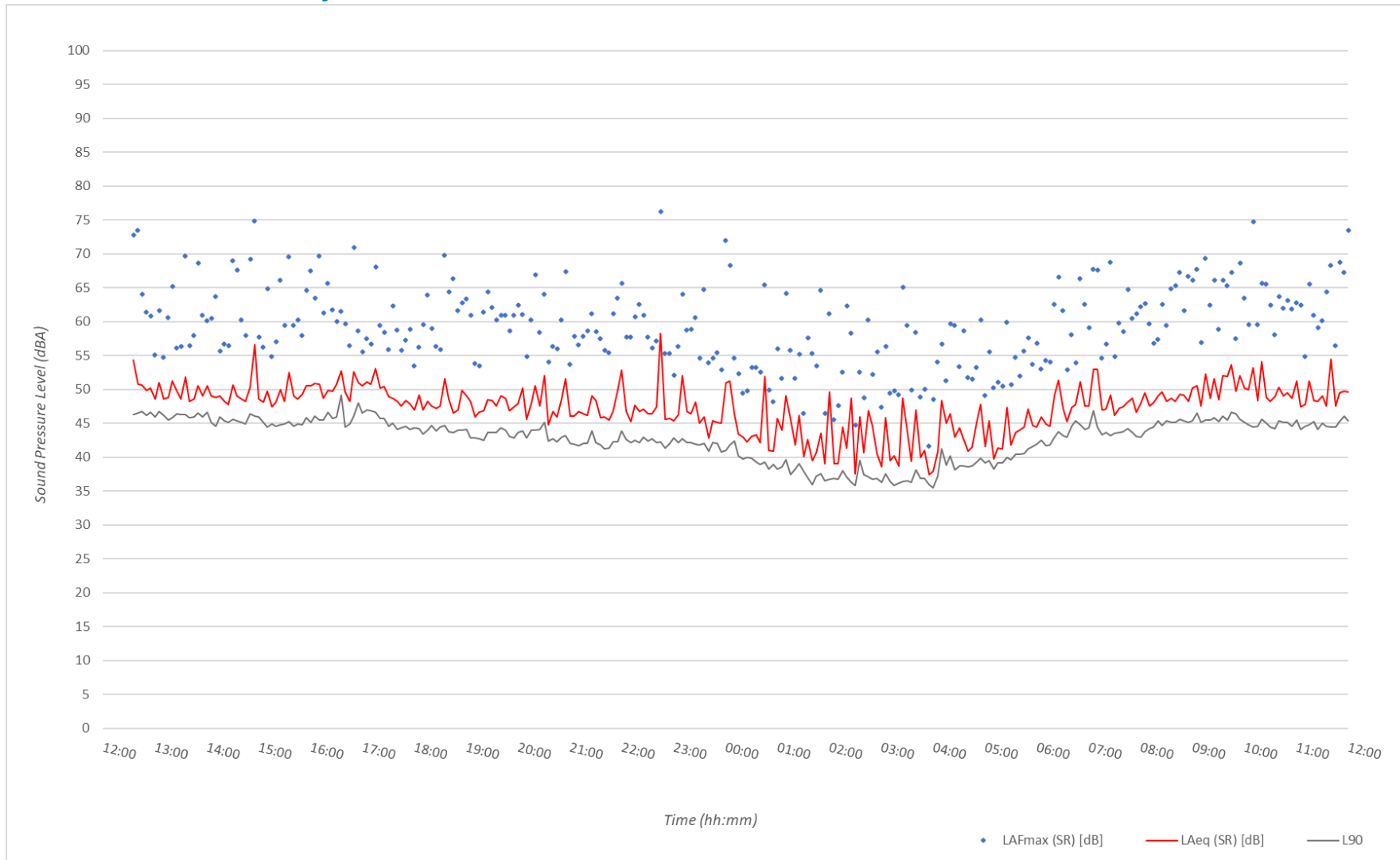

Figure 5: Measured Background Sound Levels Time History (M1): 16th – 17th December 2024

APPENDIX F - Grid Noise Maps

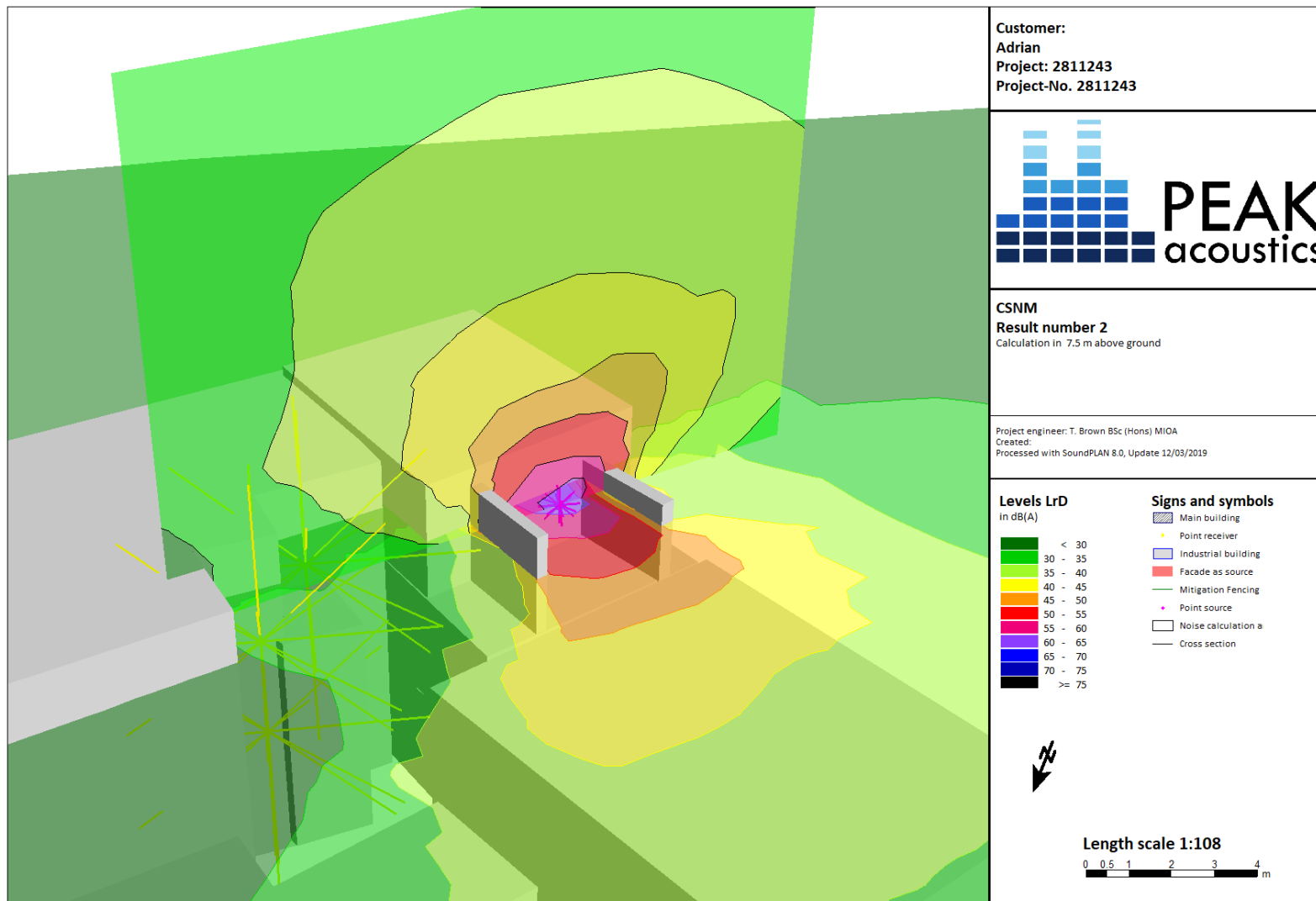

Figure 6: 3D Noise Map of night-time Initial Impact Assessment

APPENDIX G - Manufacturer Technical Data Sheets

Technical Specifications

		HPID6R32	HPID10R32	HPID13R32	HPID17R32
ErP Rating*	Heating	A+++	A+++	A+++	A+++
Height (mm)		675	882	1418	1418
Width (mm)		898	874	1024	1024
Depth (mm)		379.4	405	403	403
Weight (kg)	Empty	51	70	99	118
	Full	52.8	71.8	101	120
Heating Capacity (kW) (BS EN 14511 - air 7°C/ Water 35°C)		6.92	11.1	13.6	18.0
Power input (kW) (BS EN 14511 - air 7°C/ Water 35°C)		1.41	2.10	2.59	3.76
COP (BS EN 14511 - air 7°C/ Water 35°C)		4.91	5.28	5.25	4.79
SCOP average climate conditions (BS EN 14511 - air 7°C/ Water 35°C)		4.61	5.20	5.40	4.54
Refrigerant (R32) (kg)		0.80	1.55	2.20	2.80
Power supply		~230V 1ph 50Hz			
Water connections (BSPF)		¾"	1"	1 ¼"	1 ¼"
Min/ Max operating temperatures Air (°C)		-20/43	-20/43	-20/43	-20/43
Sound power level dB(A) (BS EN ISO 3743-1:2010)		65.2	64	60.8	61.6
Sound pressure level at 1m - external (dB(A)) (Q=1)		54.2	53	49.8	50.6
Electrical Installation Requirements					
Max running current (A)		11.2	17.5	23.0	25.3
MCB	Rating (A)	16	20	32	32
	Type	C	C	C	C

* Low temperature: 35°C flow (heating). From September 2019

HPID6R32

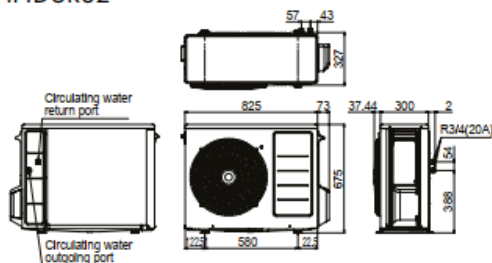

HPID10R32

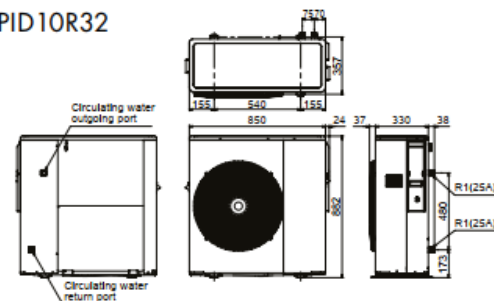

HPID13R32 & HPID17R32

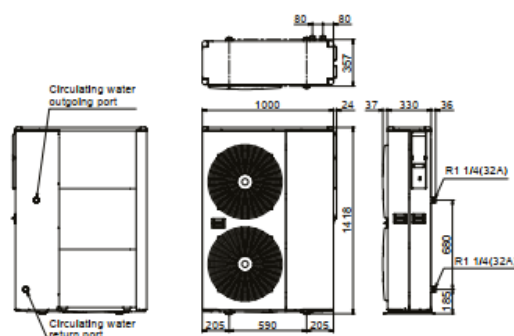

sales@grantuk.com | +44 (0)1380 736920

Figure 7: Data sourced from Grant UK Data Sheet

UKB ASHR32DS 0222

APPENDIX H - Site Plans

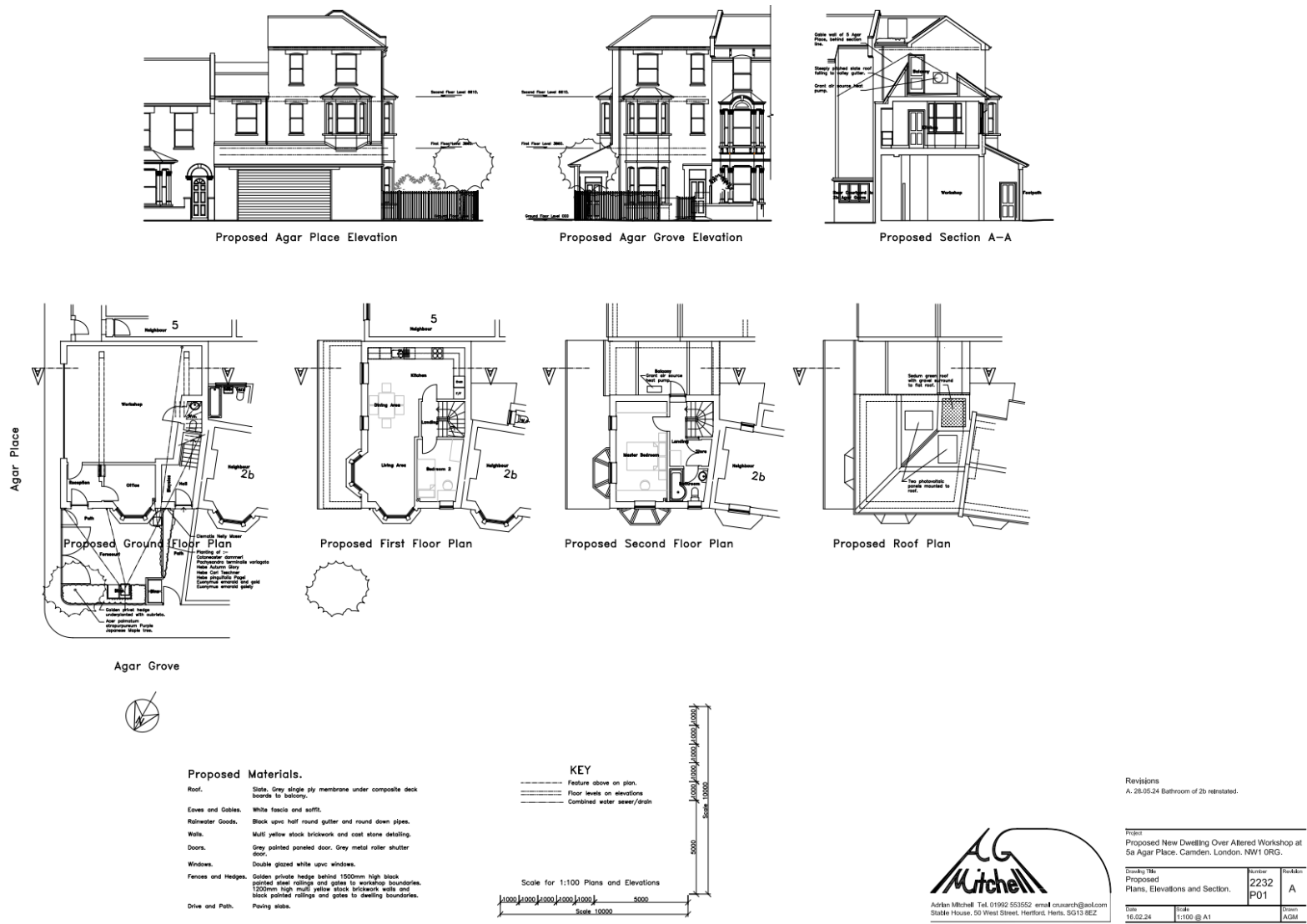

Figure 8: Site Plans Provided by 'A Mitchell Architects'

APPENDIX I - Legislation, Policy & Guidance

Guidance for the assessment of noise affecting new residential development is given in the National Planning Policy Framework (NPPF). Section 15 of the NPPF states:

“174. Planning policies and decisions should contribute to and enhance the natural and local environment by:

e) preventing new and existing development from contributing to, being put at unacceptable risk from, or being adversely affected by, unacceptable levels of...noise pollution.”

Section 185 further states:

“Planning policies and decisions should also ensure that new development is appropriate for its location taking into account the likely effects (including cumulative effects) of pollution on health, living conditions and the natural environment, as well as the potential sensitivity of the site or the wider area to impacts that could arise from the development. In doing so they should:

- A. Mitigate and reduce to a minimum potential adverse impact resulting from noise from new development – and avoid noise giving rise to significant adverse impacts on health and the quality of life;*
- B. Identify and protect tranquil areas which have remained relatively undisturbed by noise and are prized for their recreational and amenity value for this reason.”*

Section 187 states:

“Planning policies and decisions should ensure that new development can be integrated effectively with existing businesses and community facilities (such as places of worship, pubs, music venues and sports clubs). Existing businesses and facilities should not have unreasonable restrictions placed on them as a result of development permitted after they were established. Where the operation of an existing business or community facility could have a significant adverse effect on new development (including changes of use) in its vicinity, the applicant (or ‘agent of change’) should be required to provide suitable mitigation before the development has been completed.”

To avoid and mitigate adverse noise effects on health arising from and impacting new development, the NPPF makes reference to NPSE. The Noise Policy Statement for England (NPSE) was published in March 2010 and covers all forms of noise other than occupational noise.

The Noise Policy Statement for England (NPSE) states the following aims in paragraph 2.2.

NOEL – No Observed Effect Level.

This is the level below which no effect can be detected. In simple terms, below this level, there is no detectable effect on health and quality of life due to the noise.

LOAEL – Lowest Observed Adverse Effect Level.

This is the level above which adverse effects on health and quality of life can be detected.

SOAEL – Significant Observed Adverse Effect Level.

This is the level above which significant adverse effects on health and quality of life occur.

The NPSE does not define the SOAEL numerically, stating in paragraph 2.22:

“It is not possible to have a single objective noise-based measure that defines SOAEL that is applicable to all sources of noise in all situations. Consequently, the SOAEL is likely to be different for different noise sources, for different receptors and at different times. It is acknowledged that further research is required to increase our understanding of what may constitute a significant adverse impact on health and quality of life from noise. However, not having specific SOAEL values in the “NPSE provides the necessary policy flexibility until further evidence and suitable guidance is available.”

There is no local or national guidance on how the three terms should be defined numerically, it is for the assessor to collate and interpret appropriate guidance on noise, such as may be found in British Standards, and correlate the guidance with the concepts of NOEL, LOAEL and SOAEL.

BS4142:2014+A1:2019

The common standard for the assessment of industrial and commercial sound is **‘BS4142 – Methods for rating and assessing industrial and commercial sound’**. The industrial noise assessment method in BS4142 is based on the difference between the measured ‘background sound level’ (L_{A90}), and the ‘Rating Level’ of the industrial source, at a noise-sensitive location (NSR). BS4142:2014 states:

“The significance of sound of an industrial and/or commercial nature depends upon both the margin by which the rating level of the specific sound source exceeds the background sound level and the context in which the sound occurs.”

An estimation of the impact of the specific sound can be obtained by the difference between the rating sound level and the background sound level whilst considering the following:

*“A Sound Rating Level at or below the background noise level is indicative of Low Impact;
A Sound Rating Level that exceeds the background noise level by around +5dB is likely an indication of Adverse Impact, depending on the context;
A Sound Rating Level that exceeds the background noise level by around +10dB is likely an indication of Significant Adverse Impact, depending on the context;”*

BS4142 further states:

“The lower the rating level is relative to the measured background sound level, the less likely it is that the specific sound source will have an adverse impact or a significant adverse impact. Where the rating level does not exceed the background sound level, this is an indication of the specific sound source having a negligible impact, depending on the context.”

Achievement of a *Low Impact* in accordance with BS4142 along with a contextual assessment can be deemed to correspond to *‘NOEL – No Observed Effect Level’* in the NPSE.

BS8233:2014

BS8233:2014 - *Guidance on sound insulation and noise reduction for buildings* suggests indoor ambient noise levels for dwellings in Table 4, Section 7.7.2. These are summarised below.

Activity	Location	07:00 to 23:00	23:00 to 07:00
Resting	Living Room	35 dB $L_{Aeq,16hour}$	-
Dining	Dining room/area	40 dB $L_{Aeq,16hour}$	-
Sleeping	Bedroom	35 dB $L_{Aeq,16hour}$	30 dB $L_{Aeq,8hour}$

BS8233 states that the guideline values given above are for ‘noise without character’, further stating:

“Noise has a specific character if it contains features such as a distinguishable, discrete and continuous tone, is irregular enough to attract attention, or has strong low-frequency content, in which case lower noise limits might be appropriate.”

Table 4 of BS8233 also has accompanying notes that were subject to additions in ProPG. The relevant notes with the additions of ProPG are given below.

“NOTE 4 Regular individual noise events (for example, scheduled aircraft or passing trains) can cause sleep disturbance. A guideline value may be set in terms of SEL or $L_{Amax,F}$, depending on the character and number of events per night. Sporadic noise events could require separate values. In most circumstances in noise sensitive rooms at night (e.g. bedrooms) good acoustic design can be used so that individual noise events do not normally exceed 45dB $L_{Amax,F}$ more than 10 times a night. However, where it is not reasonably practicable to achieve this guideline then the judgement of acceptability will depend not only on the maximum noise levels but also on factors such as the source, number, distribution, predictability and regularity of noise events.”

“NOTE 7 Where development is considered necessary or desirable, despite external noise levels above WHO guidelines, the internal L_{Aeq} target levels may be relaxed by up to 5 dB and reasonable internal conditions still achieved.”

APPENDIX J - Acoustic Terminology

To aid the understanding of acoustic terminology and the relative difference between noise levels the following background information is provided.

We perceive sound when the ear detects fluctuations in air pressure (sound waves), which are then processed by the brain and perceived as sound. Humans can hear an incredibly wide range of sound intensities ranging from jet engines to fingertips lightly brushing against each other. This range is quantified using a logarithmic scale called the decibel scale (dB). The comfortable range of the decibel scale typically ranges from 0dB (the threshold of hearing) to around 140dB. Here are some examples of common environments and their typical noise levels.

Noise Level	Environment
0 dB(A)	Threshold of hearing
20 to 30 dB(A)	Quiet bedroom at night
30 to 40 dB(A)	Living room during the day
40 to 50 dB(A)	Typical office
50 to 60 dB(A)	Inside a moving car
60 to 70 dB(A)	Typical high street
100 to 110 dB(A)	Fire alarm at 1 metre away
140 dB(A)	Threshold of pain

Terminology

dB (decibel) – A unit used to quantify the pressure level of sound. Defined as 20 times the logarithm of the ratio between the root-mean-square pressure of a given sound field and a reference pressure level (2×10^{-5} Pa – threshold of hearing).

$L_{Aeq, T}$ – The equivalent continuous sound pressure level over a stated period. It quantifies a fluctuating sound level over a given period as the equivalent continuous sound level over which the same amount of acoustic energy is contained over. This is A-weighted in order to assess human perception.

L_{A90} – The sound level exceeded 90% of the time. Typically used to describe background noise the L_{90} is regarded as the ‘average minimum level’ and quantifies the common sound level of a fluctuating sound field i.e. the sound level that occurs 90% of the time. Alternatively, L_{10} describes the sound level exceeded 10% of the time and therefore quantifies the ‘average maximum level’ of sound which is often used during the calculation of road traffic noise.

A-Weighting – A standard weighting of the audible frequencies designed to reflect the response of the human ear to noise.

R_w – The Weighted Sound Reduction Index (R_w) is a number used to rate the effectiveness of a soundproofing system or material.