

Studio Charrette will not be responsible for any principal designer duties under CDM 2015.
 No site work is to be carried out until permissions are in place. Site searches to be carried out before any works to site.
 All structural elemental/associated calculations to be confirmed and provided by structural engineer.

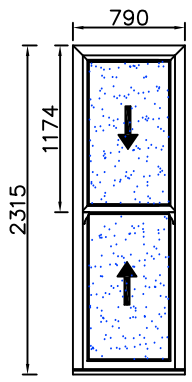

W1

Reception room
 sash and case window
 Material - timber Pine
 colour - white
 window size: 790 x 2315 mm
 Horns bespoke
 Furniture colour - polished chrome
 2 ring pulls on bottom sash and
 1 ring pull to top - chrome with
 security lock
 Glass - Float 4/16/4 Low E clear (A Rated)
 toughened bottom pane
 Spacer - black W/E
 Cill profile - 150 mm with upstands
 hidden trickle vent to head

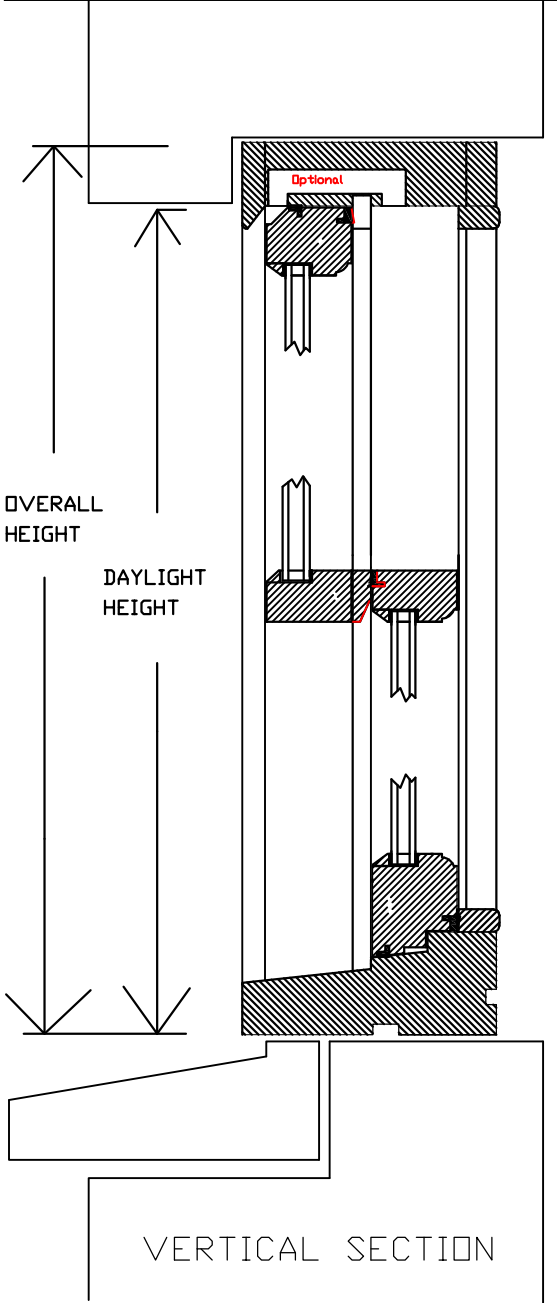
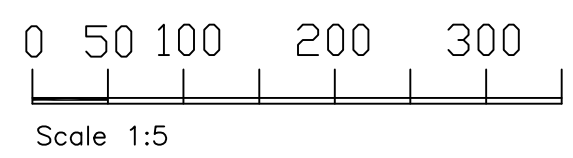
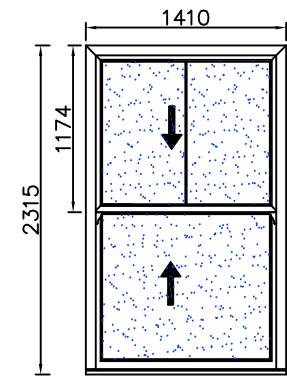

W2

Reception room
 sash and case window
 Material - timber Pine
 colour - white
 window size: 1410 x 2315 mm
 Horns bespoke
 Furniture colour - polished chrome
 2 ring pulls on bottom sash and
 1 ring pull to top - chrome with
 security lock
 Glass - Float 4/16/4 Low E clear (A Rated)
 toughened bottom pane
 Spacer - black W/E
 Cill profile - 150 mm with upstands
 hidden trickle vent to head

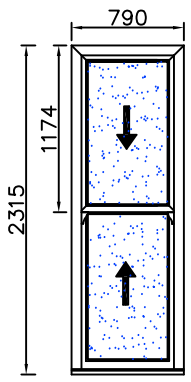

W3

Reception room
 sash and case window
 Material - timber Pine
 colour - white
 window size: 790 x 2315 mm
 Horns bespoke
 Furniture colour - polished chrome
 2 ring pulls on bottom sash and
 1 ring pull to top - chrome with
 security lock
 Glass - Float 4/16/4 Low E clear (A Rated)
 toughened bottom pane
 Spacer - black W/E
 Cill profile - 150 mm with upstands
 hidden trickle vent to head

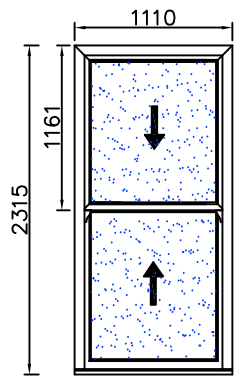

W4

Bedroom
 sash and case window
 Material - timber Pine
 colour - white
 window size: 1100 x 2290 mm
 Horns bespoke
 Furniture colour - polished chrome
 2 ring pulls on bottom sash and
 1 ring pull to top - chrome with
 security lock
 Glass - Float 4/16/4 Low E clear (A Rated)
 toughened bottom pane
 Spacer - black W/E
 Cill profile - 150 mm with upstands
 hidden trickle vent to head

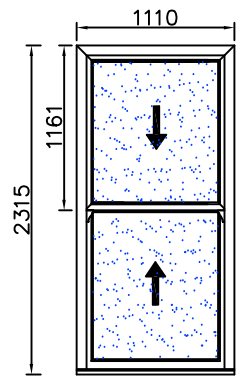

W5

Bedroom
 sash and case window
 Material - timber Pine
 colour - white
 window size: 1100 x 2290 mm
 Horns bespoke
 Furniture colour - polished chrome
 2 ring pulls on bottom sash and
 1 ring pull to top - chrome with
 security lock
 Glass - Float 4/16/4 Low E clear (A Rated)
 toughened bottom pane
 Spacer - black W/E
 Cill profile - 150 mm with upstands
 hidden trickle vent to head

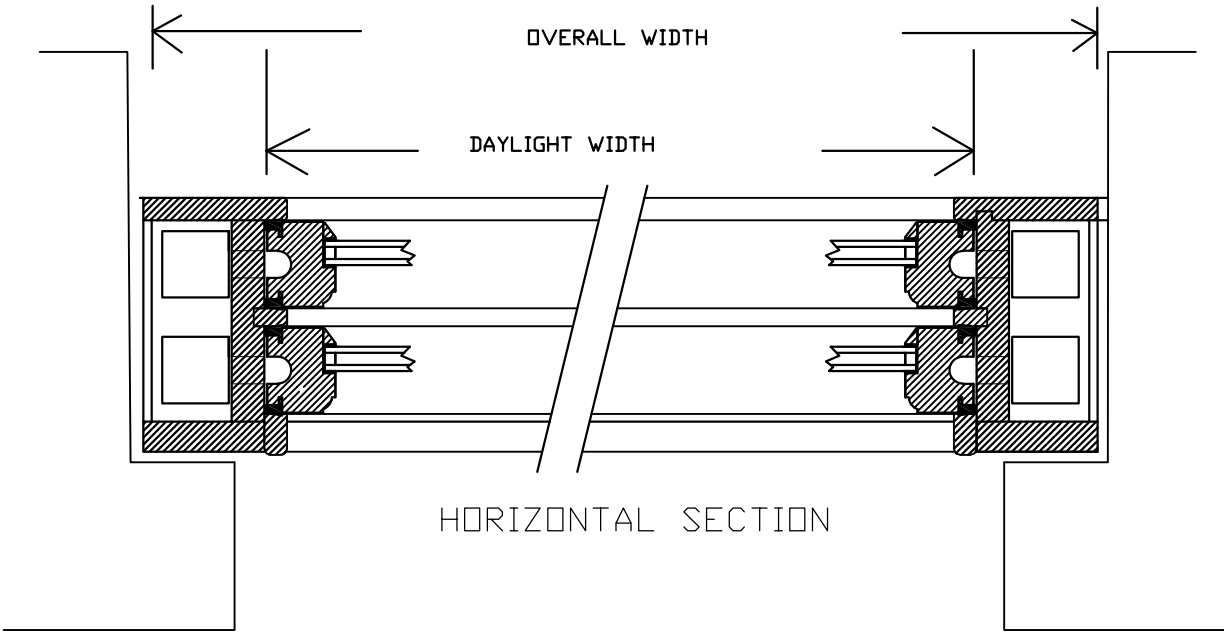

rev A - planning
 comments
 12/11/24 AM

rev B - planning
 comments
 28/11/24 AM

STUDIO CHARRETTE <small>A: The Clubhouse, 50 Grosvenor Hill, London, W1K 3QT W: www.studiocharrette.co.uk</small>	
Client Darren Rose	
Project Title Flat Hall floor, 110 Goldhurst Terrace, Camden, London NW6 3HR	
Drawing Title replacement of windows from single to double glazed on front and rear elevations	
window schedule and details	
Drawing No. SC / 24 / 322 - 301	Rev B
Scale 1:5 @ A3	Date Aug 2024
Created By A Mc	Planning
Check By	Bulking Control
	Client
	Sketch
	Information

This drawing and the copyright, design rights and all other intellectual property rights in it belong to Studio Charrette Ltd. No licence or assignment of any such rights is granted hereunder. This drawing is not to be copied or divulged to a third party without written permission.