

21st OCTOBER 2024

**LISTED BUILDING CONSENT - REVISED PROPOSAL & DRAWINGS
SECOND FLOOR FLAT. 22 CONWAY STREET. LONDON W1T 6BF**

PLEASE NOTE THAT THE SCALE IS 1:1 for the FOLLOWING DRAWINGS

THE WOOD STATION

Complete Joinery Specialists

Ray Williams Tel: 07980 731726

New Window sections:

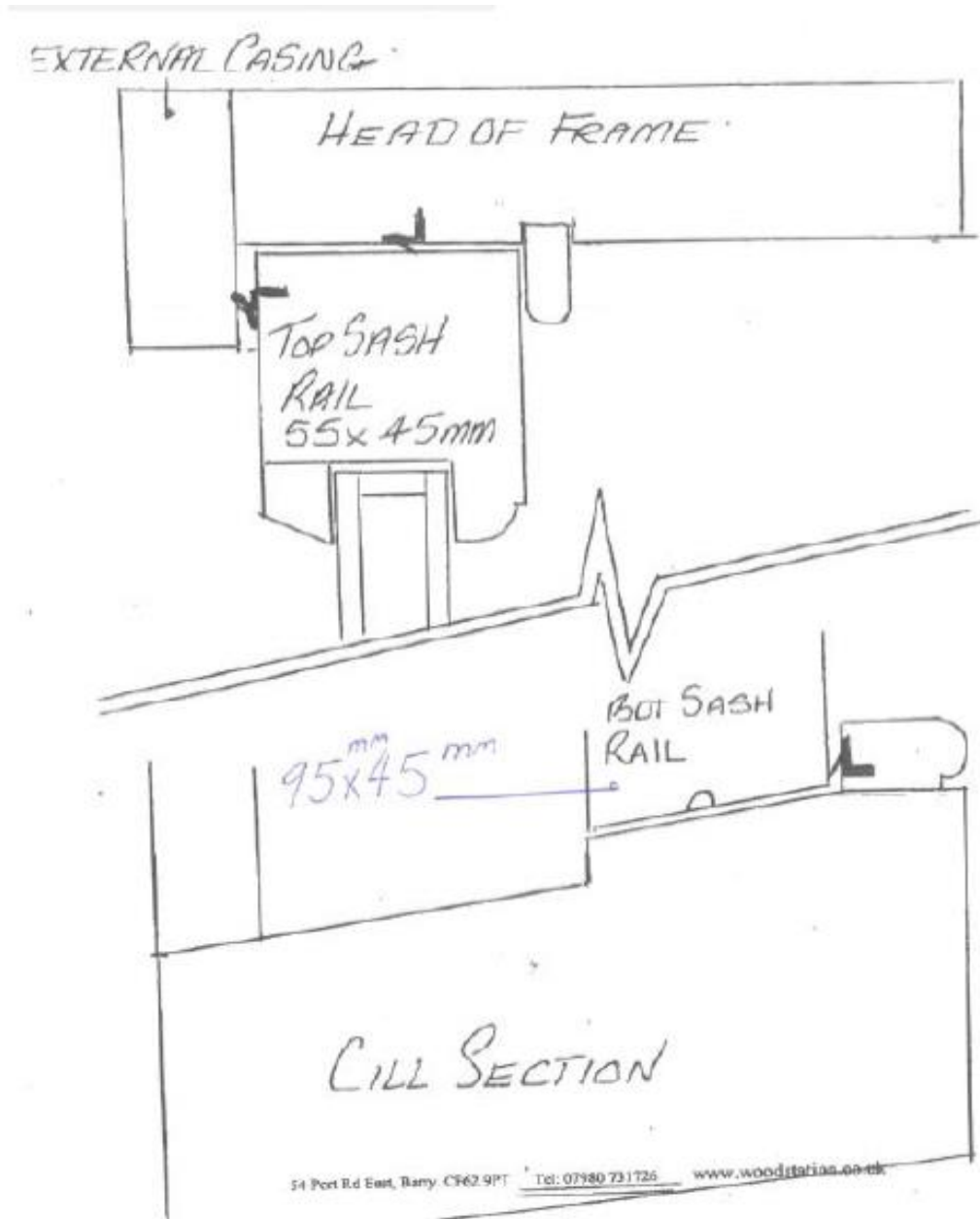

Glazing bar details

FULL SCALE

EXISTING GLAZING BAR SECTIONS

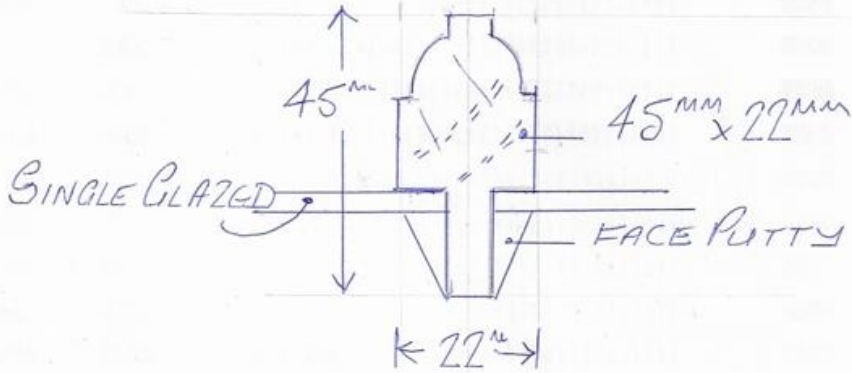

PROPOSED GLAZING BAR SECTION

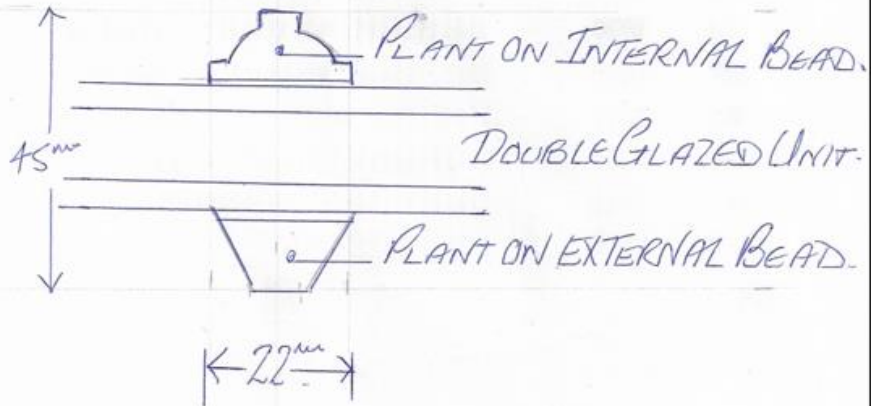

NEW PROPOSED HORN DETAIL TAKEN FROM ONE OF THE ORIGINAL SASHES
*please ignore previous submitted horn drawing detail

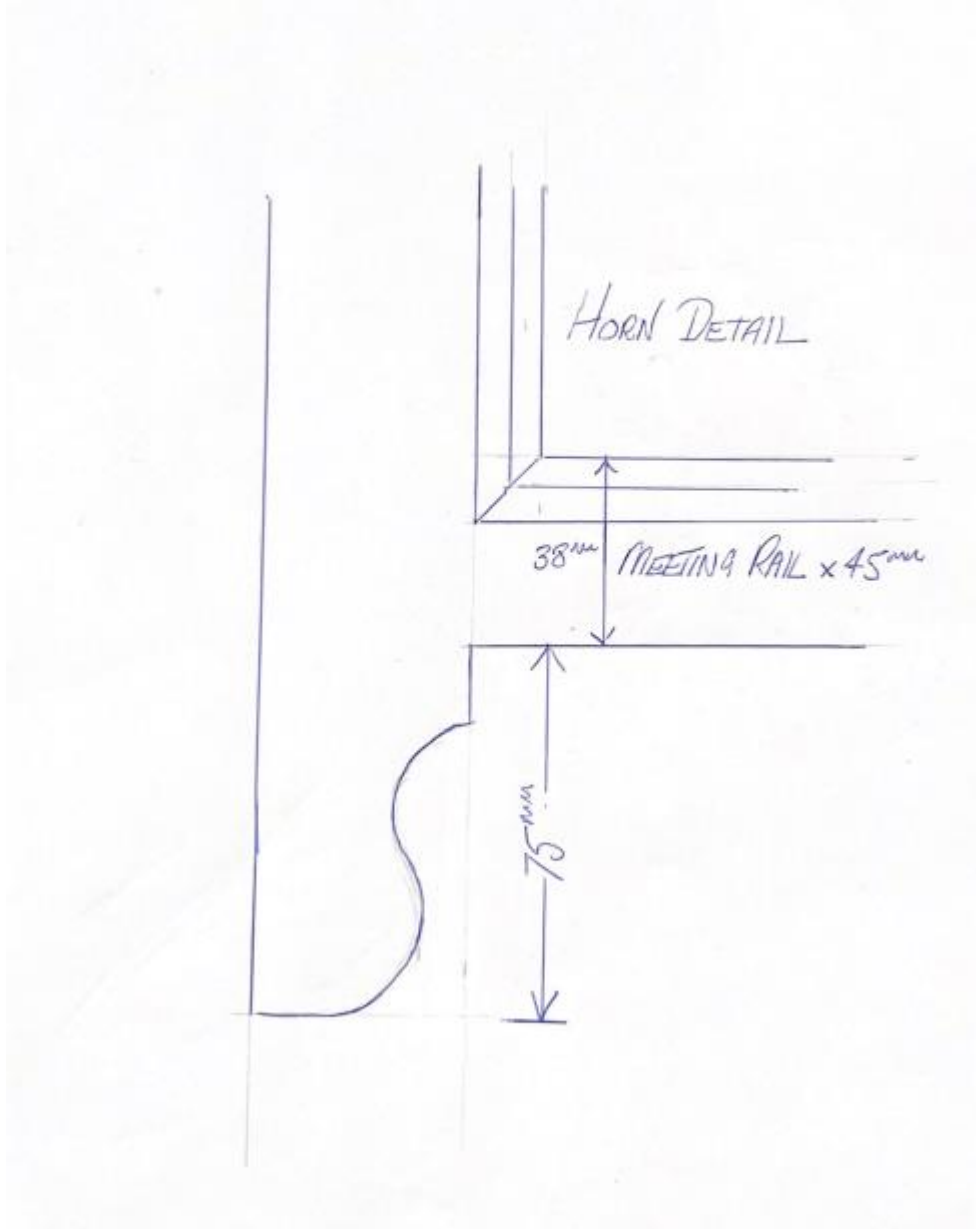

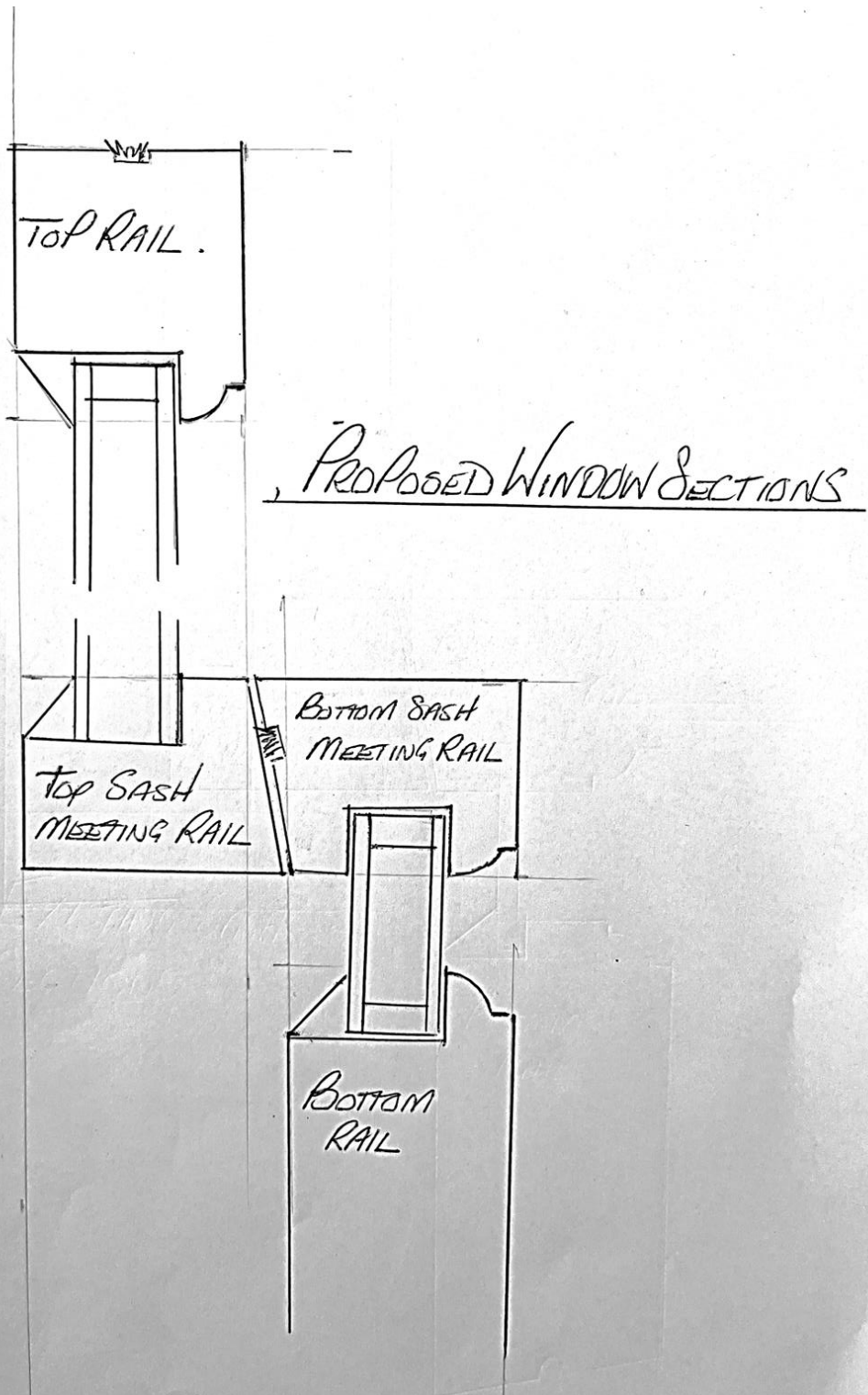

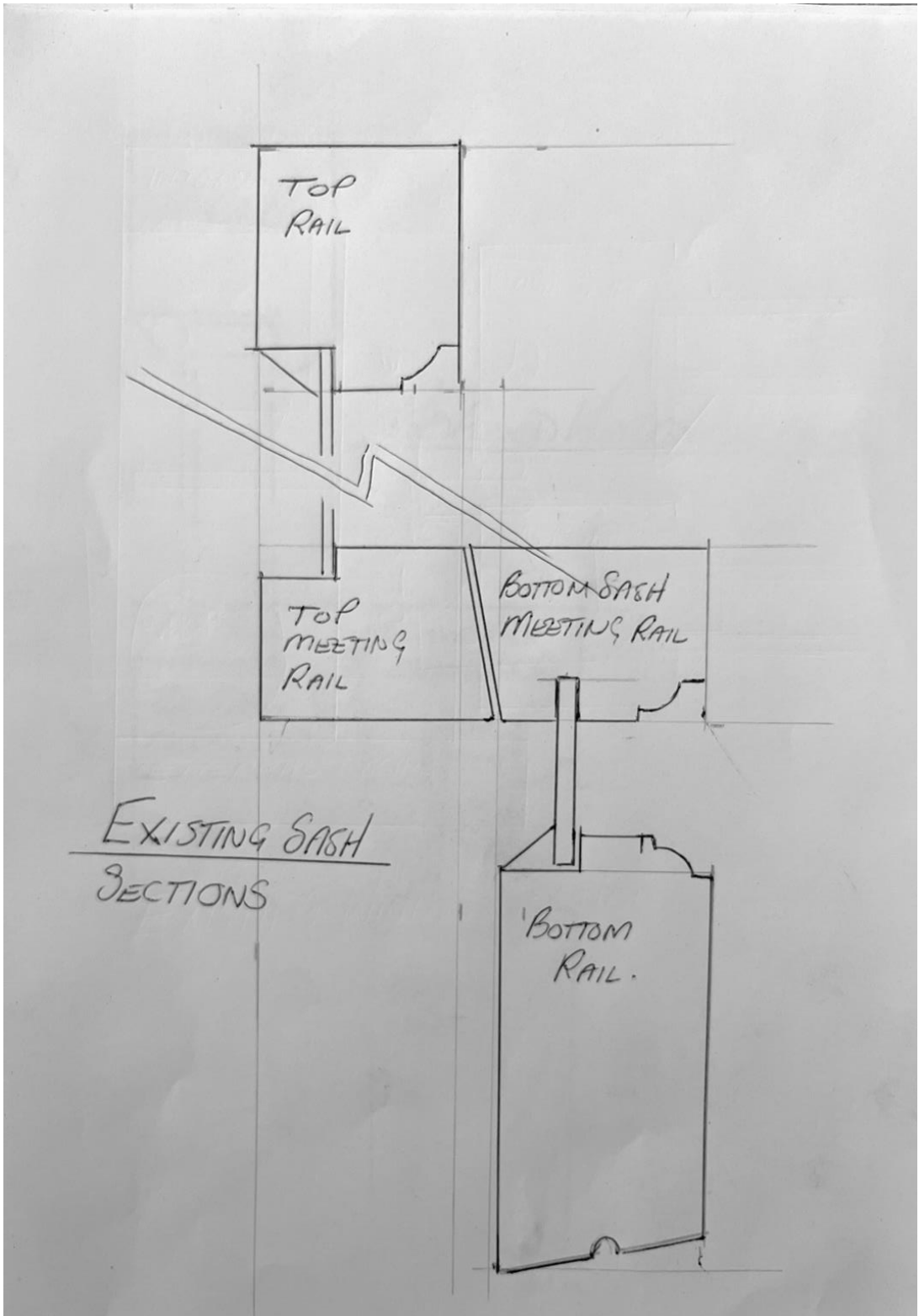

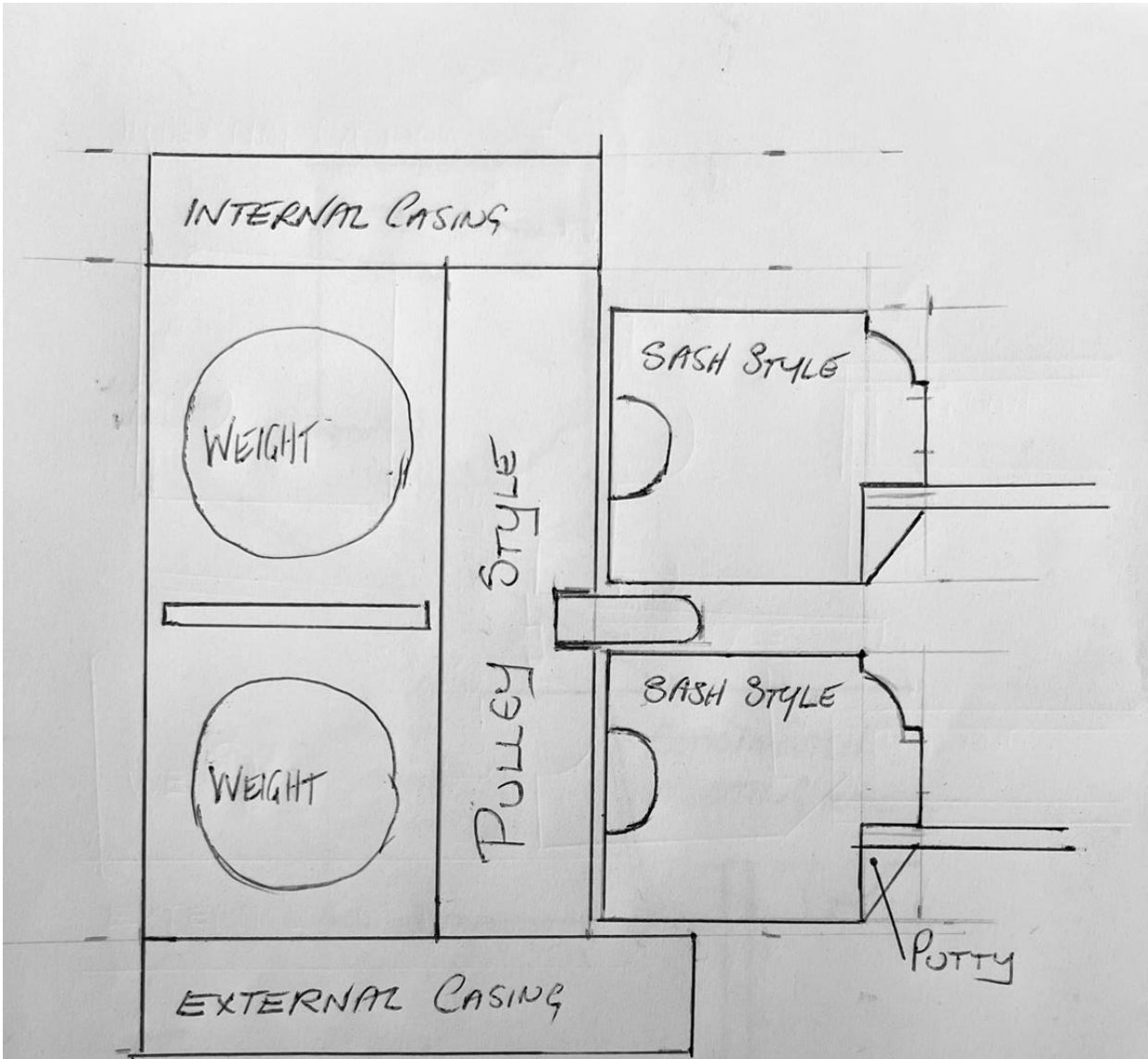

EXISTING WINDOW SECTIONS

NEW PROPOSED SASH SECTIONS USING SLIMLINE DOUBLE GLAZED UNITS

SCALE 1:1 ALL SECTION SIZES ARE TAKEN FROM ORIGINAL WINDOWS

