

.\IMG\_3704.JPEG

Existing Door for Reference

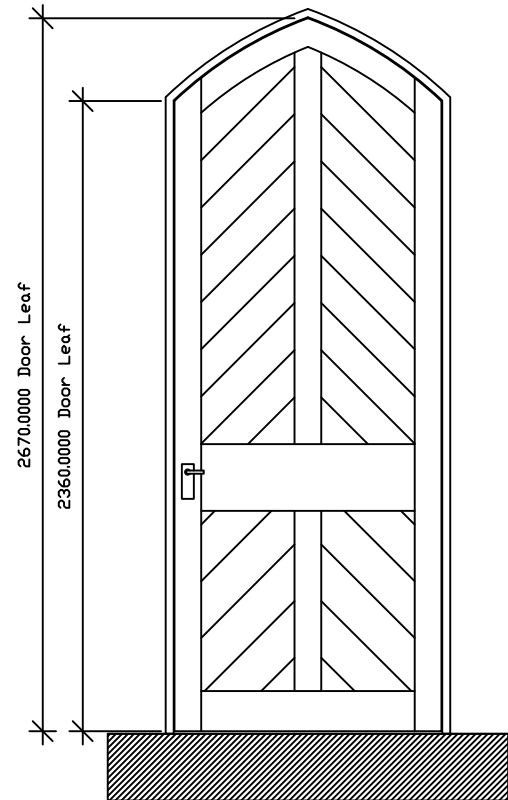

Front

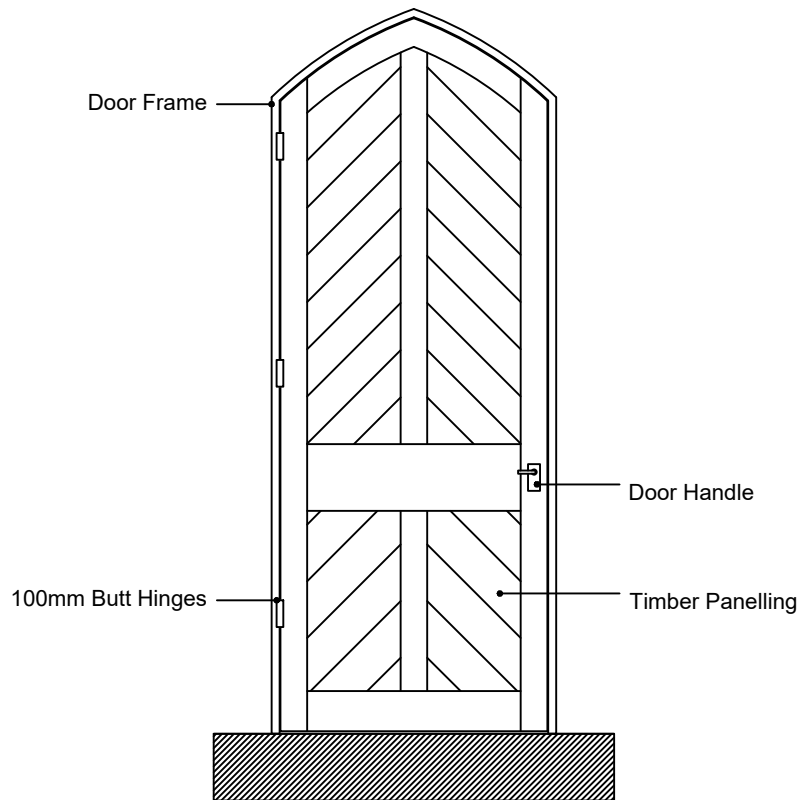

Back

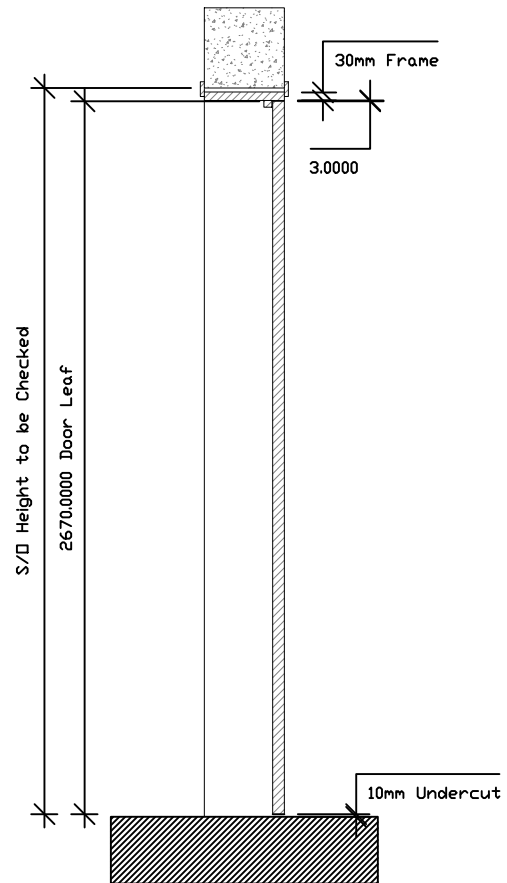

Side Section

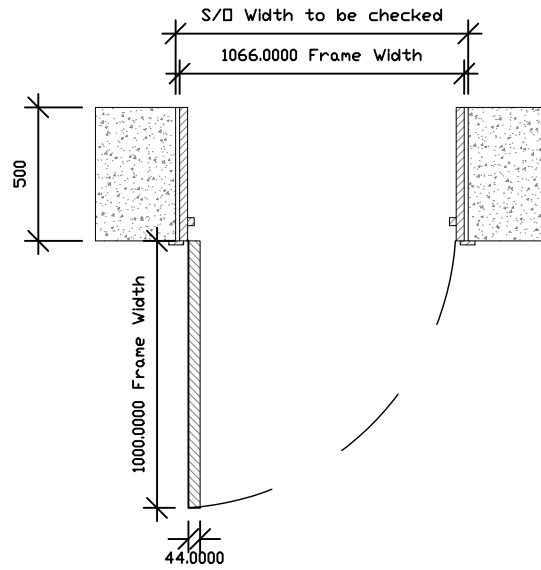

All Dimensions to be checked on site

To match existing Door set style

Confirmation of Refurbished doors to be agreed

**DRAFT**

A1

The contractor is responsible to ensure that no products are to be utilised that do not comply with relevant British Standards, European Standards and/or Codes of Practice, CDM Regulations, Construction Regulations, or which are known or suspected at the time of product selection and/or construction to be deleterious to health and safety or to the durability of the work or not in accordance with good building practice.  
The contractor is responsible for checking dimensions, tolerances, levels and references. This drawing is to be used in conjunction with all relevant drawings.  
Other Project Team Members' or specialist drawings/modifications/related Model. Any discrepancy is to be notified to Baily Garner LLP and it to be resolved before proceeding with the works on site or shop drawings. Unless an item is covered by drawings to different scales, the larger scale drawing is to be used.  
Any rights (including copyright) in this drawing/inch and any proprietary work contained herein belong to Baily Garner LLP and may only be used in accordance with the licence granted to the Employer and with attribution to Baily Garner LLP.  
This drawing is to be used in conjunction with Document Suitability Codes page or at www.bailygarner.co.uk/submitter/

Rev	Description	Date

**BAILY GARNER**  
LONDON HEAD OFFICE  
140-142 ELTHAM HILL  
LONDON SE8 5NY  
T: 020 834 1500  
E: general@bailygarner.co.uk

CLIENT: \_\_\_\_\_  
227 Vauxhall Bridge Road  
London SW1V 2EJ  
T: 020 8000 0000  
E: \_\_\_\_\_

PROJECT ADDRESS:  
Fitzjohns Primary School  
Fitzjohns Avenue  
London  
NW3 6NP

PROJECT NAME:  
Fitzjohns Door and Fenestration Replacement

DRAWING TITLE:  
Timber Solid Door - Section Plan

SUITABILITY CODE:  
Tender

SCALE	DRAWN	CHECKED	APPROVED	DATE
1:100	Designer	Checker	Approver	22/02/24

PROJ NO | AUTHOR | VOLUME | LEVEL | DOC TYPE | ROLE | DRW NO | REV NO  
35465 - BGL - - - - A - 006



.\IMG\_3694.JPEG

Existing Door for Reference

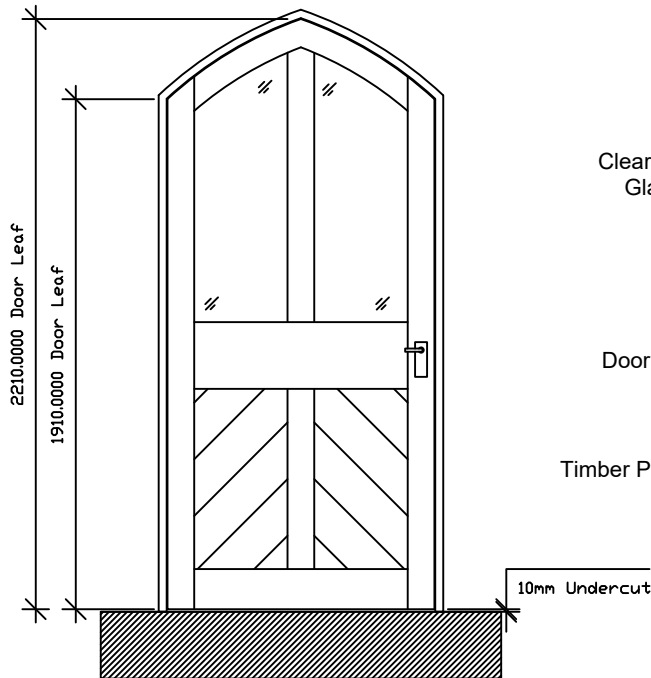

Front

Clear Toughened Glazed Panels  
Door Handle  
Timber Panelling

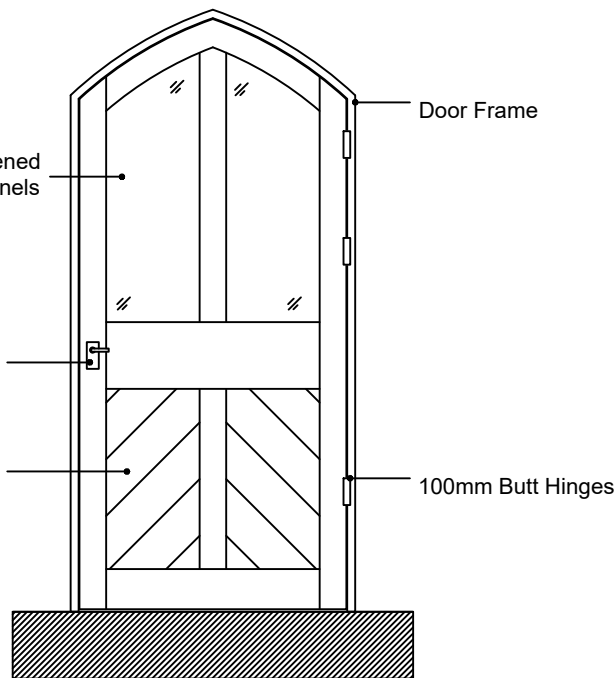

Back

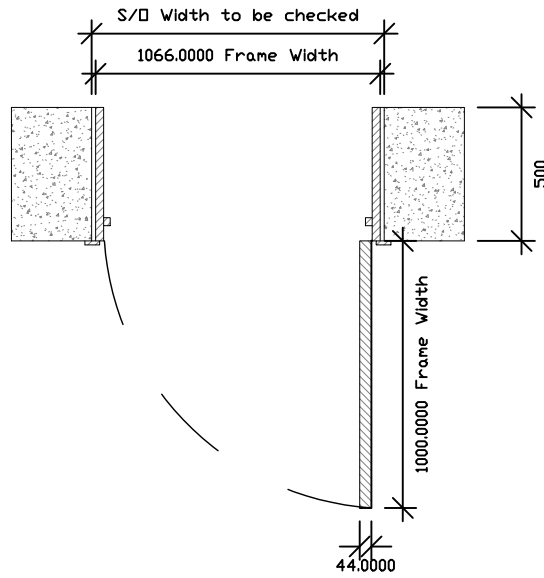

All Dimensions to be checked on site

To match existing Door set style

Confirmation of Refurbished doors to be agreed

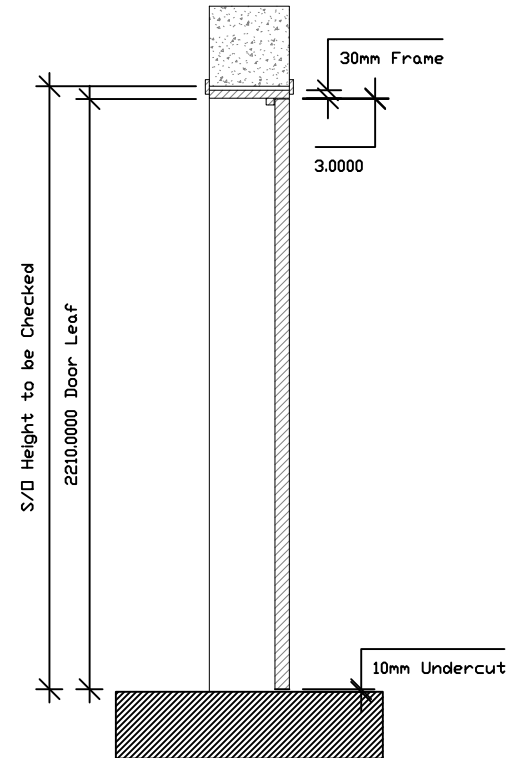

Side Section



**DRAFT**

The contractor is responsible for checking dimensions, tolerances, levels and references. This drawing is to be used in conjunction with all relevant Other Project Team Members' or specialist drawings/modernized/updated Model. Any discrepancy is to be notified to Baily Garner LLP and is to be resolved in accordance with the contract. If an issue arises, the larger scale drawing is to be used. Any rights (including copyright) in this drawing and any proprietary work contained herein belong to Baily Garner LLP and may only be used in accordance with the licence granted to the Employer and with attribution to Baily Garner LLP. The drawing is to be used in conjunction with Document Suitability Codes page or at www.bailygarner.co.uk/contractor

A1

Rev	Description	Date

**BAILY GARNER**  
LONDON HEAD OFFICE  
140-142/17TH FILL  
LONDON, SE10 5PQ  
T: 020 824 1500  
E: general@bailygarner.co.uk

CLIENT: \_\_\_\_\_  
227 Vauxhall Bridge Road  
London SW1V 2EU  
T: 020 824 1500  
E: \_\_\_\_\_

PROJECT ADDRESS  
Fitzjohns Primary School  
Fitzjohns Avenue  
London  
NW3 6NP

PROJECT NAME  
Fitzjohns Door and Fenestration Replacement

DRAWING TITLE  
Timber Glazed Door - Section Plan

SUITABILITY CODE  
Tender

SCALE	DRAWN	CHECKED	APPROVED	DATE
1:100	Designer	Checker	Approver	22/02/24

PROJ NO | AUTHOR | VOLUME | LEVEL | COC/VP | ROLE | DRW NO | REV NO  
35465 - BGL - - - - A - 007