

This drawing is copyright and may not be copied or reproduced without the written consent of this practice

The contractor is responsible for setting out and must check all levels and dimensions prior to work being put in hand

This drawing should not be scaled. Only written dimensions are to be taken in respect of this project

The Architect is to be immediately notified of any suspect omissions or discrepancies

REV DATE COMMENT REV BY

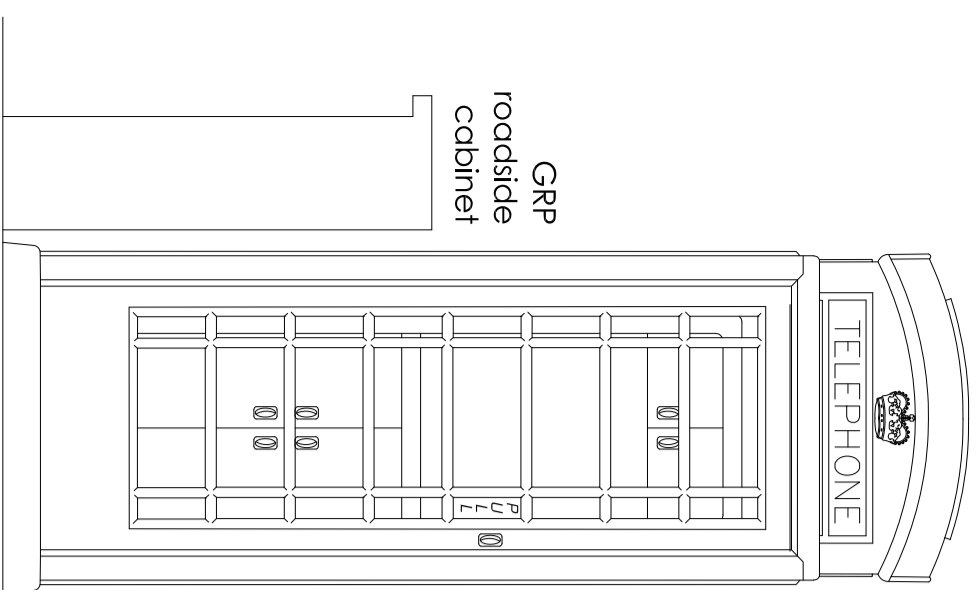

Proposed Front Elevation @ 1 : 20



Proposed Rear Elevation @ 1 : 20

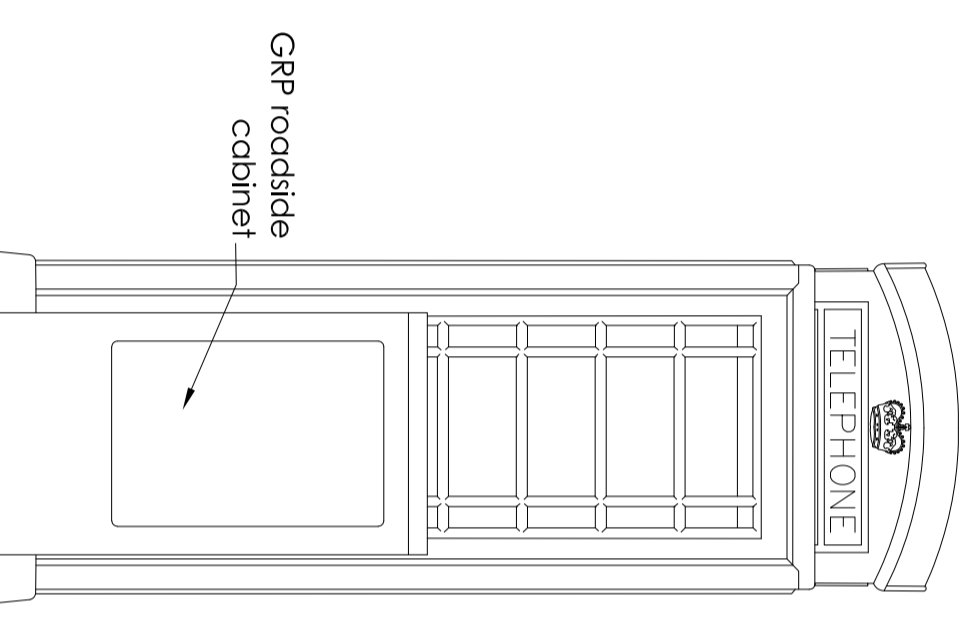

Proposed Side Elevation 1 @ 1 : 20

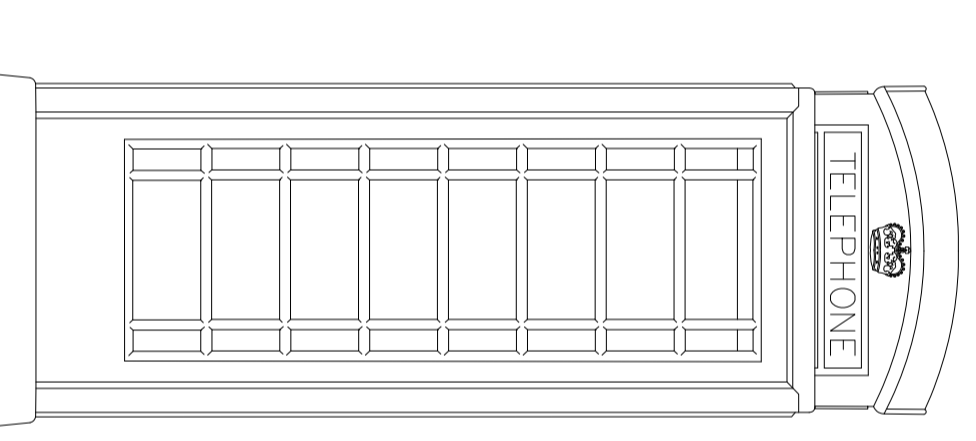

Proposed Side Elevation 2 @ 1 : 20

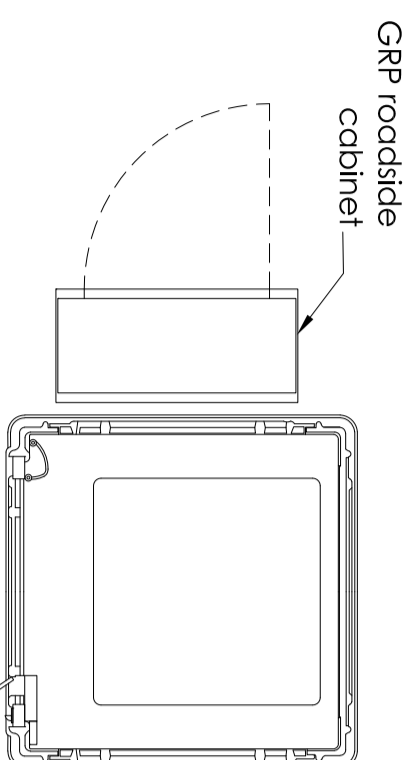

Proposed Plan Showing Door Closed @ 1 : 20

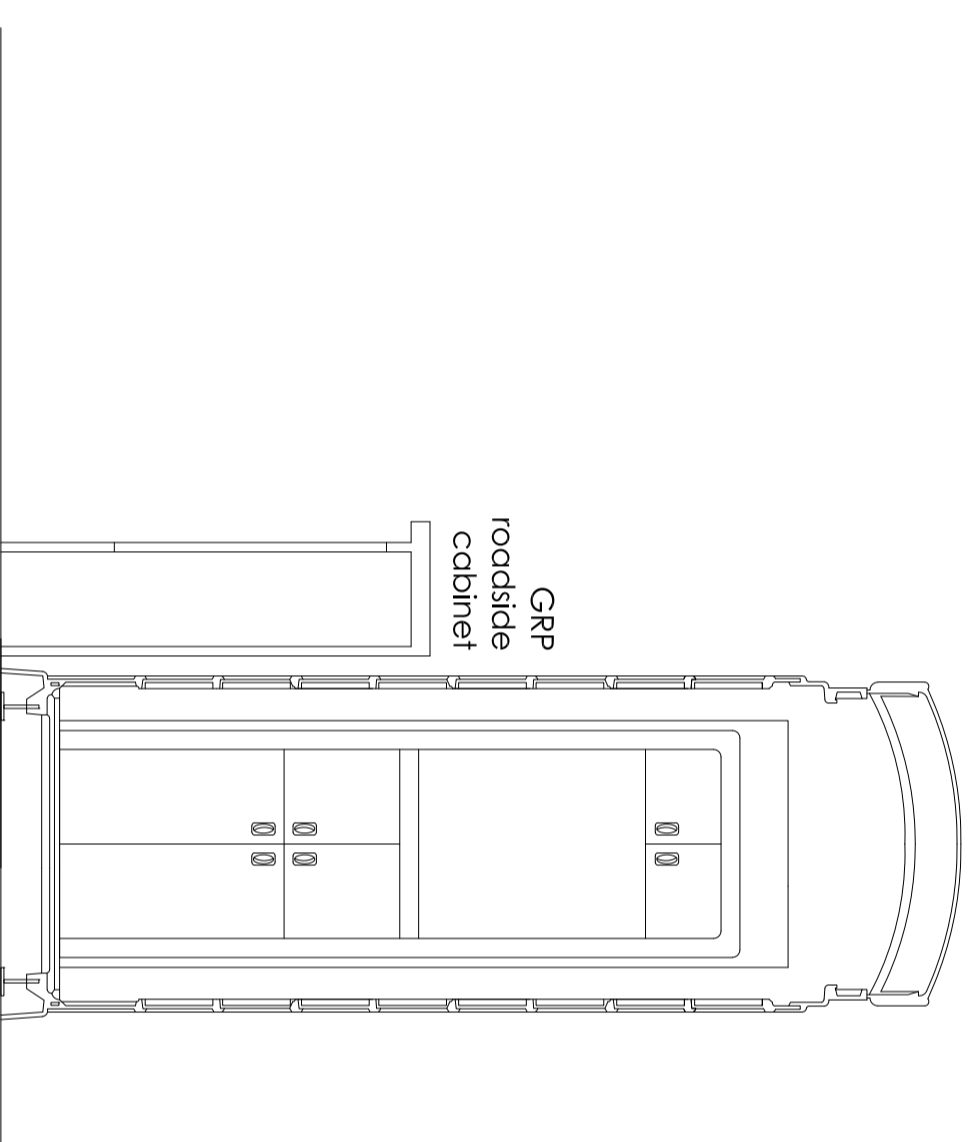

Proposed Section A-A @ 1 : 20

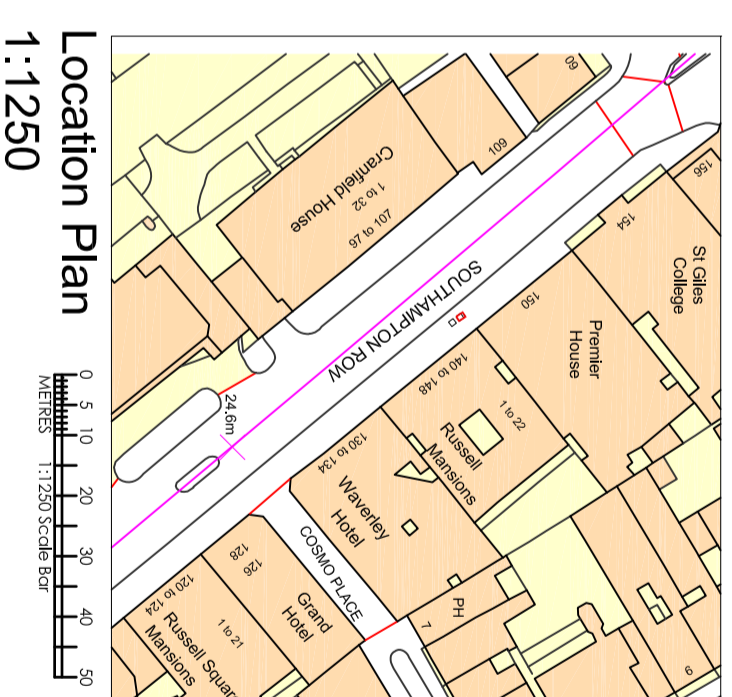

Location Plan 1:1250

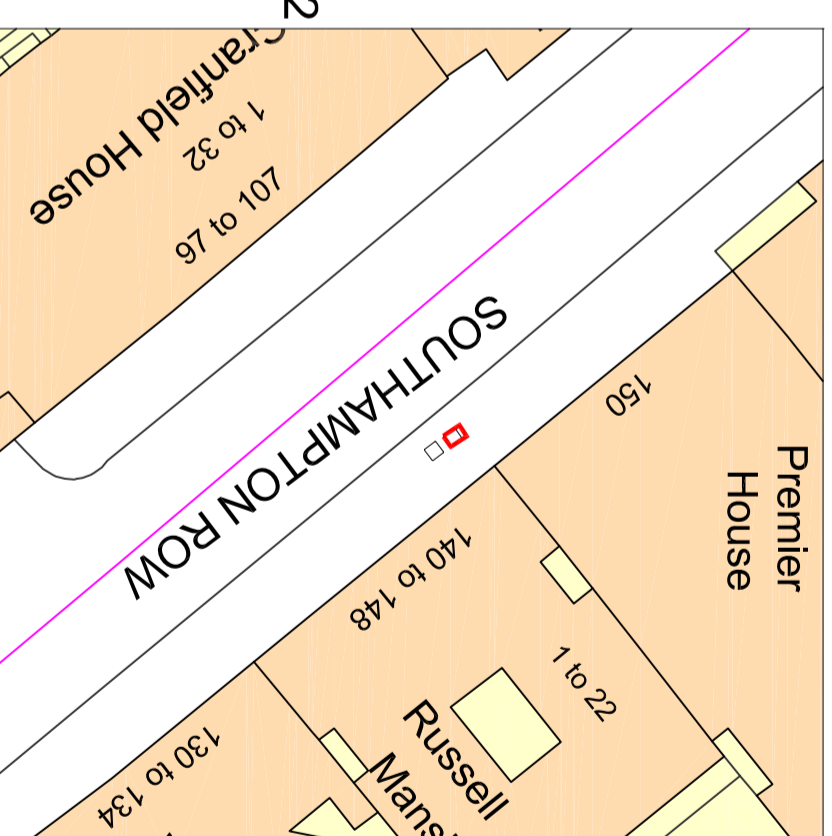

Block Plan 1:500

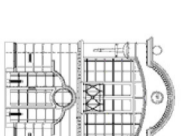

**BROE ARCHITECTURE LTD**  
CHARTERED ARCHITECTS

60 Haven Way  
Newhaven,  
East Sussex, BN9 9TD  
Telephone: 01273 468917  
www.broearch.co.uk

CLIENT

Trustees of Collins Cairns Pension  
Scheme

PROJECT

LDC APPLICATION FOR  
POWER-SUPPLY CABINET TO  
SERVE RETAIL USE @  
1NO. K6 PHONE BOX OUTSIDE  
148 SOUTHAMPTON ROW,  
LONDON,  
WC1B 5AG

DRAWING

**PROPOSED PLANS, ELEVATIONS &  
SECTIONS AND EXISTING BLOCK  
& LOCATION PLANS - K6 KIOSK**

scale	date	drawn
1:20, 1:500	Oct 2024	FMB
1:1250 @ A2		

job no	drawing no	revision
9975	PL02	.