

TYPE E1: PROPOSED SECTION

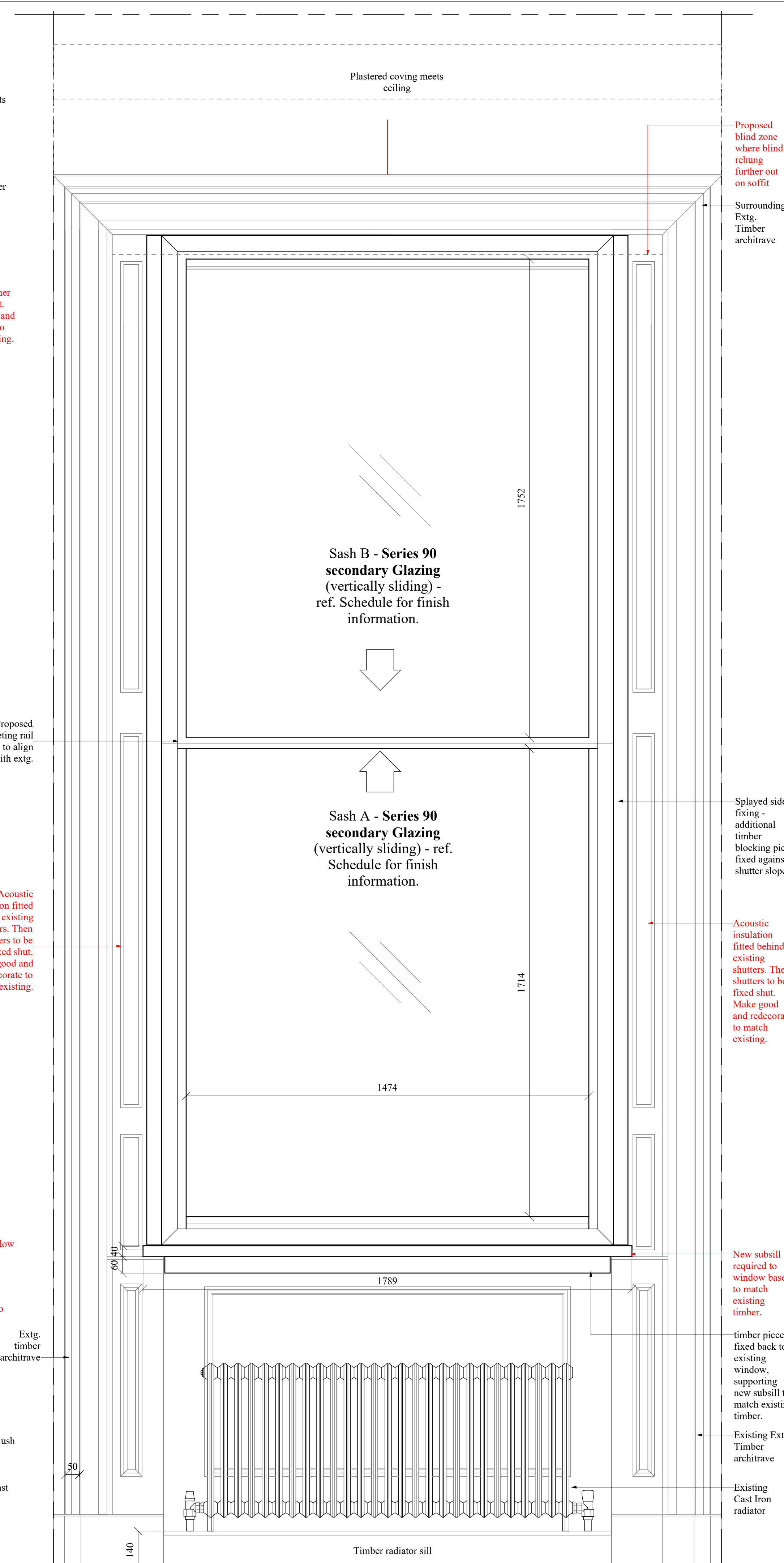

TYPE E1: PROPOSED ELEVATION

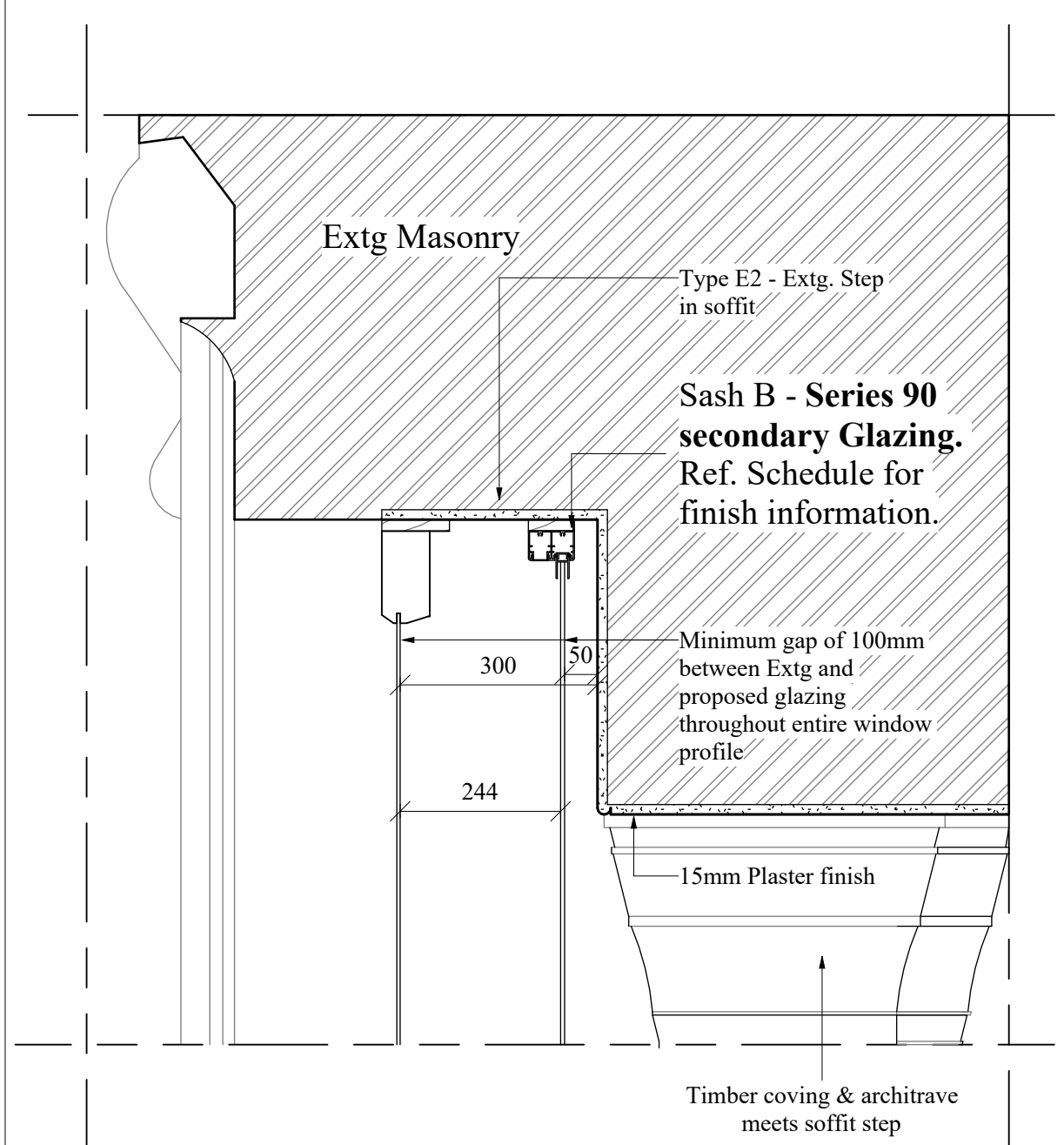

TYPE E2: PROPOSED SECTION
(details elsewhere repeated as E1)

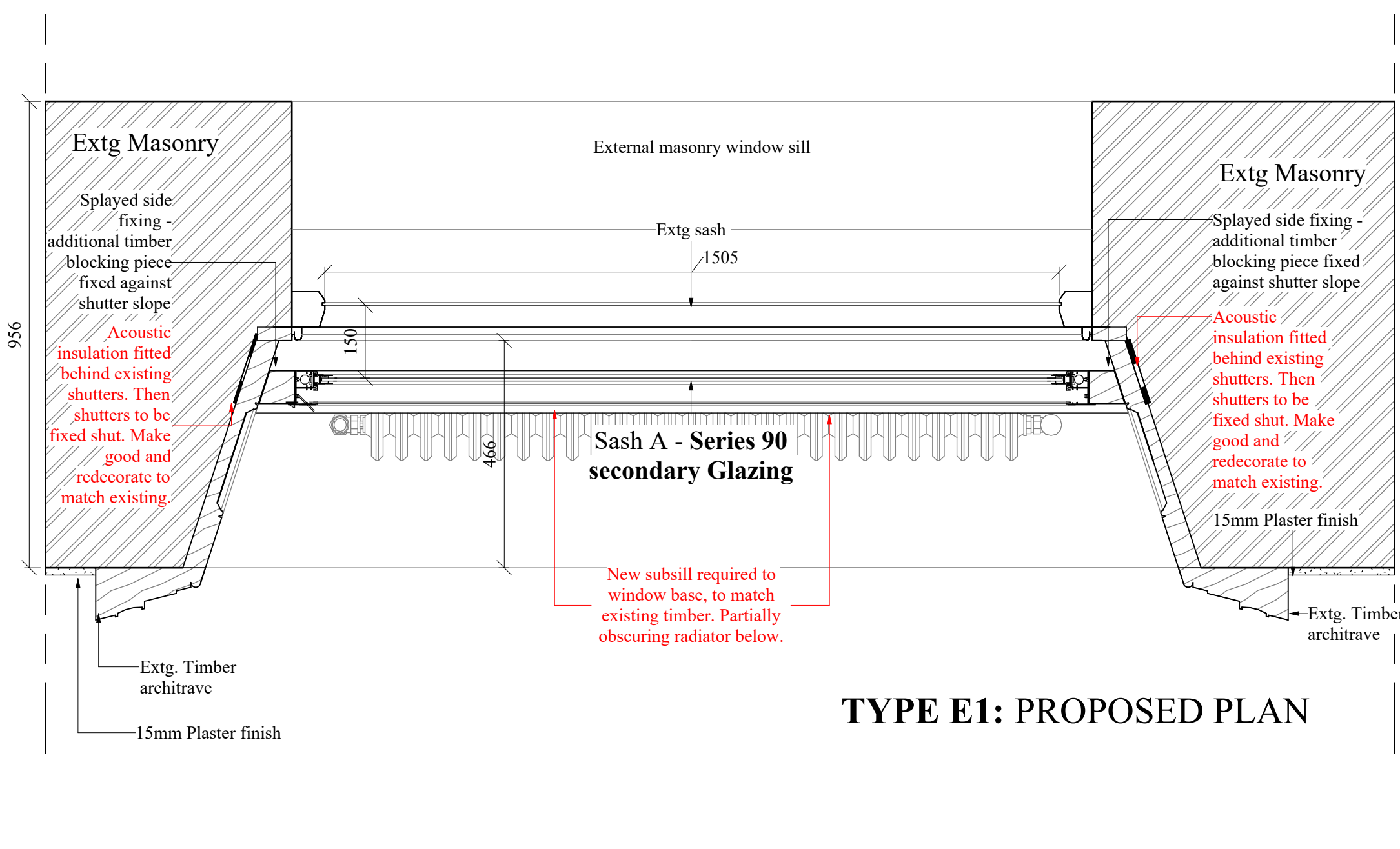

TYPE E1: PROPOSED PLAN

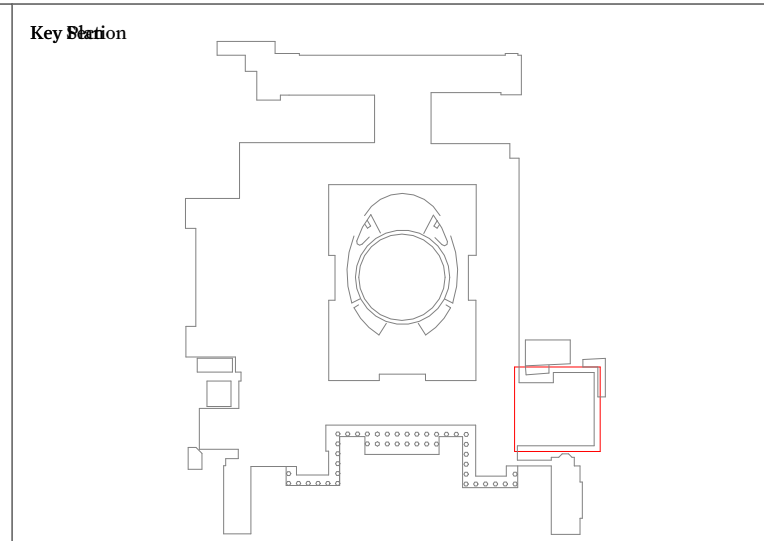

This drawing is not to be scaled. Dimensions govern. Wright & Wright Architects shall be notified in writing of any discrepancies. All dimensions are in millimeters unless noted otherwise. This drawing issued at First Contract is indicative of design intent and should be read in association with all specifications, schedules and consultants information. The Contractor is required to complete the detailed design, final coordination and interfaces. Contractor and Sub-Contractors design are subject to Architects acceptance.

Note: Drawings to be read in conjunction with the LBC design statement and installed to manufacturers guidance. Refer to design statement for further information on fixing details.

P4	Tender revision	09.08.2024	JB	BM
P3	For information	05.07.2024	JB	BM
P2	For approval	10.05.2024		
P1	WIP issue	11.04.2024		

Rev	Note	Date	Issued By	Issued To
-----	------	------	-----------	-----------

Security Classification: **Official**

WRIGHT & WRIGHT ARCHITECTS

89-91 Bayham Street
London NW1 0AG
T +44(0)20 7428 9393
E www@wrightandwright.co.uk

Client
British Museum

Project Name
Energy Centre Programme: Noise Mitigation

Stage
RIBA Stage 4

Drawing Title
Type E1&E2 ECP Noise Mitigation Proposed

Drawing Number
SW001-WWA-1140-B-DDG-A-5116

Scale Sheet Size Issue Date
1:10 A1 09.08.2024

Revision Status
P4 S4 - For approval