

## DESIGN & ACCESS STATEMENT

Philips Building  
SOAS University of London

2<sup>nd</sup>, 3<sup>rd</sup> & 4<sup>th</sup> Floor Office/Teaching Room Door Replacements



August 2024 (V1)

## TERMS OF REFERENCE

This Design and Access Statement has been prepared by Neville Bruton Design on behalf of the School of Oriental and African Studies (SOAS), to support an application for listed building consent for the replacement of interior office/teaching room doors within the Grade II\* Philips Building, SOAS University of London, Thornhaugh Street, London, WC1H 0XG.

This application addresses Camden Planning Enforcement Notice (ref: EN24/0279, 12 April 2024) in respect to carrying out works not covered by the original consent granted for the refurbishment of the 2<sup>nd</sup>, 3<sup>rd</sup> & 4<sup>th</sup> floor corridor areas of the Philips Building (2022/5402/L, granted 18 April 2023) and is submitted following discussions in respect to an agreed course of remedial action, with the Camden Planning Enforcement Team and the designated Planning Officer (2 July 2024).

It should be read in conjunction with other application documentation.

## VISION & OBJECTIVES

The works covered by this application, comprise:

- The replacement of interior office/teaching room doors and associated ironmongery within the 2<sup>nd</sup>, 3<sup>rd</sup> & 4<sup>th</sup> floor corridor areas of the Grade II\* Philips Building.
- Please refer to *Existing Layout & Finishes* later in this document

The proposals do not seek to increase the building's area or introduce significant changes in design or material finish.

SOAS are committed to the preservation of its listed assets. The challenge is to design and specify a scheme which respects the integrity and maintains the preservation of the building.

## BACKGROUND

The Grade II\* Philips Building forms part of the SOAS central London campus, associated to the University of London and includes, the (Holden Building) College Building (Grade II), the Brunei Gallery, the Paul Webley Wing of Senate House (Grade II\*), which sit within Sub Area 3 of the Bloomsbury Conservation Area and 53 Gordon Square (Grade II), which sits within Sub Area 2 of the Bloomsbury Conservation Area.

*Please refer to the accompanying Heritage Statement for further detail*

## Location Plan

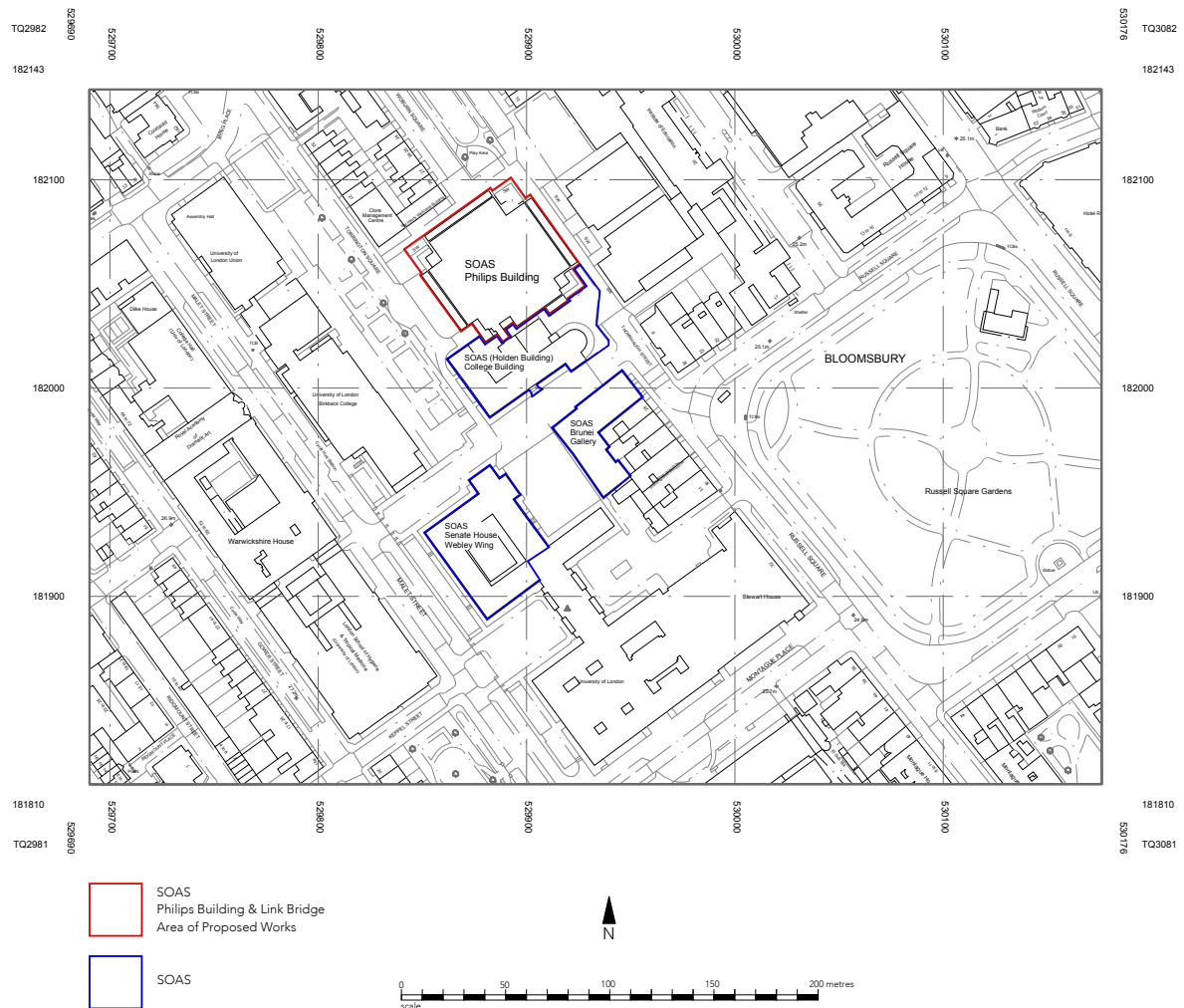

SOAS is home to leading research and expertise on the global issues of today. Students engage with academics on these issues throughout their study.

It is uniquely placed to inform and shape current thinking about the economic, political, cultural, security and religious challenges of our world.

Its decolonial outlook on education allows it to strive for a more equal and just world through its teaching and research. It is committed to building bridges within the global communities and forging equitable global partnerships.

It challenges perspectives, broaches debate, and empowers its students to question the global status quo and find solutions to the issues facing the world today.

Its programmes are taught by respected international academics with inter-disciplinary expertise. These scholars are engaged in fieldwork and research that influences governments, industries and communities across the world.

SOAS has a very diverse student base, from over a hundred different countries, and has a number of unique courses.

SOAS cater for approximately 6,145 students on campus with a further 2,140 off campus/distant learning students – Supported by 1,010 academic and professional services staff.

The Philips Building houses one of only five National Research Libraries in the UK, with over 1.5 million volumes, periodicals and audio-visual materials in 400 languages, focusing on Asia, Africa and the Middle East. It also provides teaching rooms, academic and administration offices and welfare facilities.

A full overview of the SOAS offer can be viewed at: <https://www.soas.ac.uk>

## DESIGN BRIEF

The decision to replace the existing office/teaching room doors responds to both Building Regulations and the Fire Strategy for the building, in ensuring that both emergency escape routes and fire compartmentation are compliant for both building occupancy and use.

## DESIGN APPROACH

The design approach has been based on the following principles:

- To sustain the significance of the listed building
- To maintain the viable use of the building
- To find solutions that do not adversely impact on either the interior or exterior of the building or its context within the site.
- To undertake modifications and repairs in a sensitive way, respecting the integrity of the original fabric with sympathetic use of new materials and finishes

## POLICY CONTEXT

The proposals have been developed with reference to:

- English Heritage 'Conservation Principles, Policies and Guidance' 2008
- Planning (Listed Buildings and Conservation Areas) Act 1990
- National Planning Policy Framework 2021
- Camden Core Strategy 2010-2025 'Policy CS14 – Promoting high quality places and conserving our heritage
- Bloomsbury Conservation Area Appraisal and Management Strategy – Adopted 18 April 2011

*Please refer to the accompanying Heritage Statement for further detail*

## DESIGN PRINCIPLES

The design proposals covered within this application provide a uniform approach to the refurbishment of the 2<sup>nd</sup>, 3<sup>rd</sup> & 4<sup>th</sup> floor corridor areas of the Philips Building (reference granting of consent 2022/5402/L) and which has also been extended to the 5<sup>th</sup> floor corridor area under consent 2024/0128/L.

The primary focus of the proposals is to ensure statutory fire compliance through the upgrading of office/teaching room doors to provide a minimum 30-minute fire rating.

The layout of the building is to remain unchanged and the proposed works will not have an undue impact on the building or its surrounding environment.

#### USE

The use of the building will remain the same

#### APPEARANCE

It is hoped that the works will have a positive impact on the appearance of the interior of the building. The potential impact the proposed work will have, is detailed within the section 'Statement of Justification' later in this document.

#### ACCESS

The proposed scope of works to the interior of the building do not represent a material change of use so do not require the wholesale upgrading of the building to comply with The Building Regulations Approved Document Part M except where material alterations are made, however the Equality Act 2010 and the Equality (Disability) Regulations 2010 requires service providers to make reasonable adjustments to any physical features that might put a person with a disability at a "substantial disadvantage".

Primary access to the Philips Building is via the College Building and the Link Bridge connection. There is both stepped and ramped access with intermediate landing points to the main entrance of the College Building, with step free access also available to the rear of the College Building. Both entrances offer lift access to upper floor levels and the Link Bridge to the Philips Building.

The Link Bridge connection between the College Building and Philips Building has a shallow ramped floor, the double leaf fire doors at the head of the ramp are fitted with magnetic hold opens with fail release under fire condition.

SOAS do not propose to structurally alter any of existing access points as part of the proposals under this application.

#### EXISTING LAYOUT & FINISHES

The circulation corridor routes of the 2<sup>nd</sup>, 3<sup>rd</sup> and 4<sup>th</sup> floors follow the perimeter core of the building and provide access to teaching rooms, administration offices, welfare facilities, lifts and staircases.

#### EXISTING CORRIDOR DOORS - 2<sup>nd</sup>, 3<sup>rd</sup> & 4<sup>th</sup> Floor Corridors

Please refer to the accompanying planning drawings:

- SOAS-PB-L2-010 Rev C Philips Building Level 2
- SOAS-PB-L3-010 Rev C Philips Building Level 3
- SOAS-PB-L4-010 Rev C Philips Building Level 4

This application covers the replacement of office/teaching room doors and associated ironmongery only – For a complete picture, details of other doors within the corridor areas are also included for reference.

- Original Office and Teaching Room Doors - Replaced:  
Flush panel single leaf doors with paint finish, replaced with new FR30 flush panel doors with stained finish (2023/24)
- Later Addition Office and Teaching Room Doors - Replaced:  
Plastic laminate faced flush panel single leaf doors with overhead panels, replaced with new FR30 flush panel doors with overhead panels, with stained finish (2023/24)
- Later Addition Male & Female Toilet Doors – Retained covered under 2022/5402/L:  
Flush panel cherry veneered single leaf doors
- Later Addition Mid Corridor Fire Doors – Upgraded as part of consent 2022/5402/L:  
1½ leaf flush panel oak veneered doors with vision panel to main leaf
- Later Addition Stair Doors – Retained covered under 2022/5402/L:  
Double flush panel cherry veneered doors with vision panels
- Service Riser Doors – Retained covered under 2022/5402/L:  
Flush panel doors with painted finish
- Later Addition Library Doors (3<sup>rd</sup> Floor) – Retained covered under 2022/5402/L:  
Double leaf ash veneered flush panel doors with ash veneer reveal cladding panels, clear natural finish.





2<sup>nd</sup> Floor  
 Typical corridor view pre refurbishment  
 Office/teaching room decorated flush panel doors  
 with stained hardwood frames, architraves & skirtings



3<sup>rd</sup> Floor  
 Typical corridor view pre refurbishment  
 Office/teaching room decorated flush panel doors  
 with stained hardwood frames, architraves & skirtings



4<sup>th</sup> Floor – pre refurbishment  
 Office/teaching room decorated flush panel doors  
 with stained hardwood frames, architraves & skirtings



4<sup>th</sup> Floor - pre refurbishment  
 Office/teaching room later addition laminate faced  
 flush panel door with fixed panel over

## NEW REPLACEMENT DOORS - 2<sup>nd</sup>, 3<sup>rd</sup> & 4<sup>th</sup> Floor Corridors

Whilst falling outside the scope of the original consented works (2022/5402/L), SOAS have undertaken the replacement of office/teaching room doors, comprising original painted flush panel doors and later addition plastic laminate faced flush panel doors and associated ironmongery.

The decision to replace the existing doors responds to both Building Regulations and the Fire Strategy for the building, in ensuring that both emergency escape routes and fire compartmentation are compliant for both building occupancy and use.

Whilst the existing doors to the office/teaching rooms could have been retro fitted with smoke seals, SOAS could not confidently state that in doing so, the doors would provide the requisite minimum 30-minute fire check. To address these concerns, SOAS have undertaken replacement of the original doors with new FR30 flush panel doors, with a stained finish to colour match the original retained hardwood door frames, architraves and skirtings, which were lightly refurbished under consent 2022/5402/L.

The replacement flush panel doors, fitted within the original door frames, provide and maintain a visual link to the original painted doors removed, whilst also providing uniformity of appearance between floors.



Typical corridor view across 2<sup>nd</sup>, 3<sup>rd</sup> & 4<sup>th</sup> floor corridors - post refurbishment (2022/5402/L)  
New FD30 flush panel doors, stained finished to match refurbished retained door frames, architrave & skirting



Typical corridor view across 2<sup>nd</sup>, 3<sup>rd</sup> & 4<sup>th</sup> floor corridors - post refurbishment (2022/5402/L)  
New FD30 flush panel doors, stained finished to match refurbished retained door frames, architrave & skirting





New FD30 flush panel door, stained finished to match refurbished retained door frames, architrave & skirting



New FD30 flush panel door with fixed panel over, stained finished to match refurbished retained door frames, architrave & skirting

#### DOOR IRONMONGERY – EXISTING & PRE-EXISTING

As part of the office/teaching room door replacements undertaken within the 2<sup>nd</sup>, 3<sup>rd</sup> & 4<sup>th</sup> floor corridor areas, new ironmongery has been installed, comprising, new antique brass Motril lever handles with escutcheon (fig .1. & .2.). These replacements however are considered unacceptable by Camden and form part of the Enforcement Notice (ref: EN24/0279, 12 April 2024), requiring alternatives more in keeping to the original lever handles, to be sourced and submitted for approval.

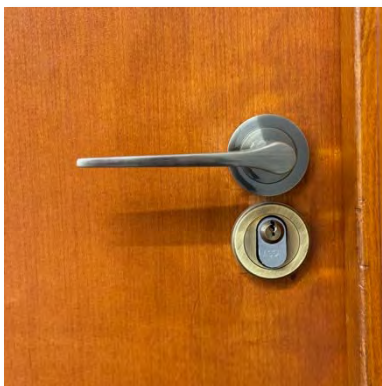

Fig .1.

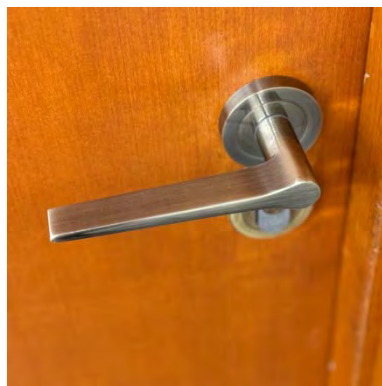

Fig .2.

Proposals for replacing the recently installed office/teaching room door furniture will also assist in informing consent for the proposed scope of refurbishment of the Philips Building 5<sup>th</sup> floor corridor area, reference 2024/0128/L, granted 29 July 2024 with condition in respect to ironmongery.

To address the Enforcement Notice, the following action was agreed with Camden:

- SOAS are to provide Camden Planning Enforcement Team with photographic reference to existing door ironmongery installed within the 5th floor corridor area of the Philips Building along with contemporary equivalent examples for their proposed replacement, for approval.

The following survey records the type of lever handle door furniture installed on the single leaf flush panel office/teaching room doors located within the 5th floor corridor area of the Philips Building.

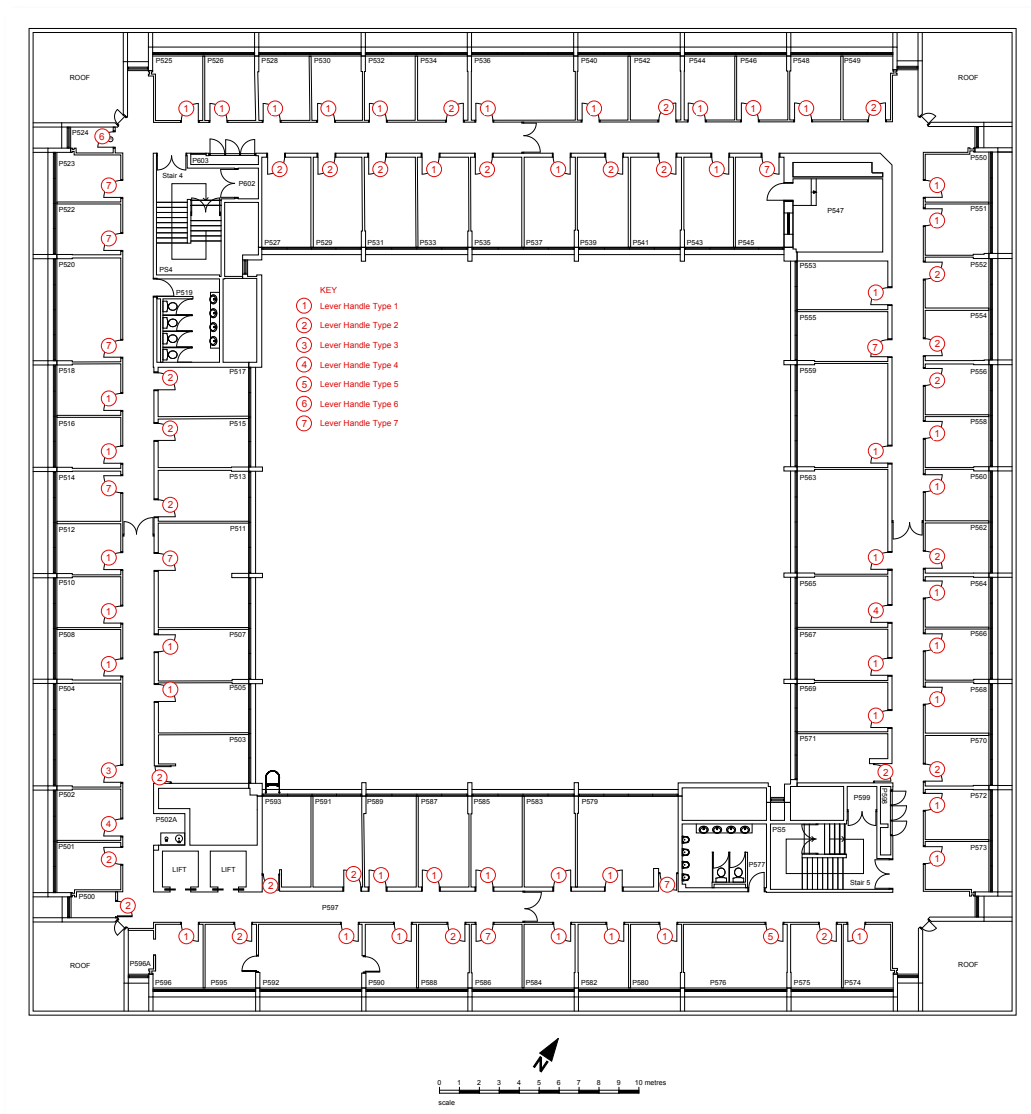

Philips Building Existing 5<sup>th</sup> Floor Plan - Door Furniture Key

Whilst original to the building, lever handles (Type 1) remain fitted to approximately 53% of the doors within the area, natural wear and tear during the building's 50-year history has required replacements to be installed, these being of different design, typically Type 2, with variations Type 3 & 4. It is assumed, based on the percentage of matching Type 2 design, that these represent a main period of Type 1 replacement.

The design of Type 2 (3 & 4) are later faux versions of the popular d line solid stainless steel ironmongery range, designed by Danish Architect Knud Holscher in the early 1970's a design that is

still widely imitated today. It is assumed that these lower quality faux replacements began to be installed during the mid 1990's.

Additional security digital locks (Type 7) have also been fitted to a number of higher security areas as have a number of isolated ad hoc lever handle replacements (Type 5 & 6).

From the photographic records taken of the 2<sup>nd</sup>, 3<sup>rd</sup> & 4<sup>th</sup> floor corridors prior to refurbishment works being undertaken (please refer to 2022/5402/L D&A Statement), none of the floors contained 100% original door furniture, with lever handle Type 1, being replaced with later addition Type 2 & 3 lever handles.

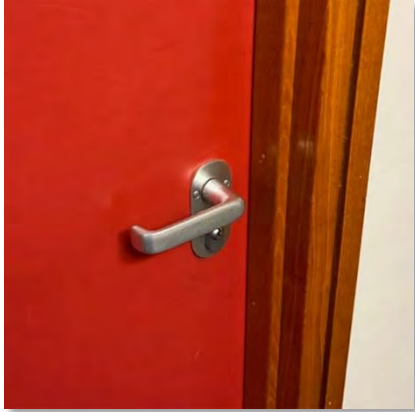

#### **Lever Handle Type 1**

Original 1973 ironmongery installation:

Aluminium lever handle with oval backplate incorporating cut-out for oval lock cylinder

Fitted to approximately 53% of doors within the 5<sup>th</sup> floor corridor

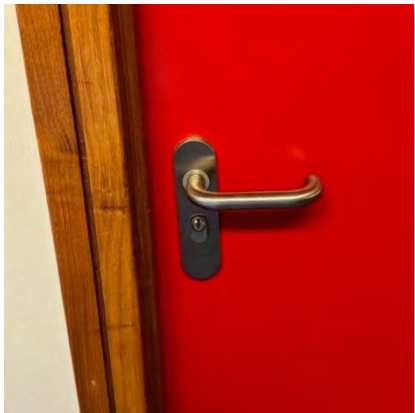

#### **Lever Handle Type 2**

Later addition satin stainless steel return to door lever handle with oval cover backplate incorporating cut-out for oval lock cylinder

Fitted to approximately 31% of doors within the 5<sup>th</sup> floor corridor, reflecting a major period of Type 1 lever handle replacement

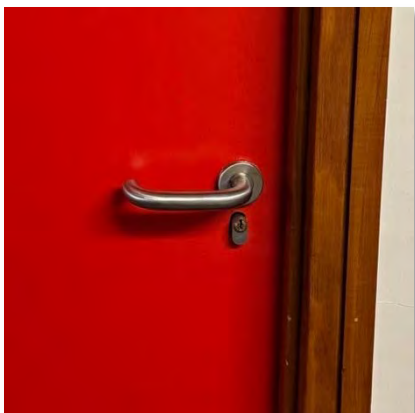

#### **Lever Handle Type 3**

Later addition satin stainless steel return to door lever handle with rose and separate oval lock cylinder

Fitted to approximately 3% of doors within the 5<sup>th</sup> floor corridor – Lever handle mirrors Type 2, but due to the use of a rose rather than backplate it is assumed to be a later replacement

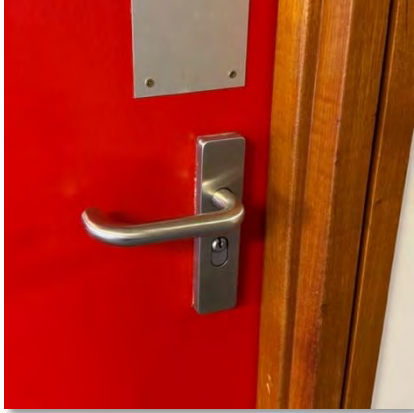

#### **Lever Handle Type 4**

Later addition satin stainless steel return to door lever handle with rectangular cover backplate incorporating cut-out for oval lock cylinder

Fitted to approximately 1% of doors within the 5<sup>th</sup> floor corridor – Lever handle mirrors Type 2, but due to a differing backplate it is assumed to be a later ad hoc replacement

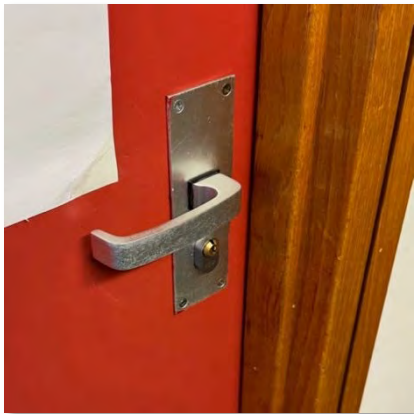

#### **Lever Handle Type 5**

Later addition aluminium ad hoc lever handle replacement with integral rectangular back plate incorporating cut-out for oval lock cylinder.

Fitted to approximately 1% of doors within the 5<sup>th</sup> floor corridor

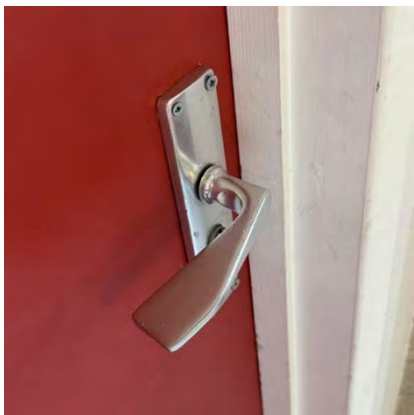

#### **Lever Handle Type 6**

Later addition aluminium ad hoc lever handle replacement with integral rectangular back plate incorporating cut-out for oval lock cylinder

Fitted to approximately 1% of doors within the 5<sup>th</sup> floor corridor

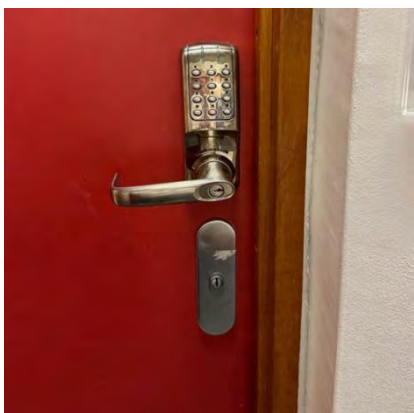

#### **Digital Lock Type 7**

Later addition digital lock above oval cover backplate incorporating cut-out for oval lock cylinder

Fitted to approximately 10% of doors within the 5<sup>th</sup> floor corridor



## PROPOSED REPLACEMENT IRONMONGERY

SOAS accept Camden's concern that the current replacement ironmongery installed on the 2<sup>nd</sup>, 3<sup>rd</sup> & 4<sup>th</sup> floors (Motril lever handles fig .1. & .2.) is not in keeping with the original door furniture removed and have investigated alternatives which respond to Camden's concerns.

Following on-line research and discussions with ironmongery suppliers and manufacturers, we have concluded that the original 1970's aluminium lever handle door furniture (Type 1), is no longer commercially available, added too which, the use of aluminium in the production of commercial ironmongery has largely been replaced with stainless steel, being a more robust and hygienic alternative.

Due to security requirements, SOAS propose to retain/reinstate the digital locks (Type 7), where required.

Whilst not supplied with an integral backplate as the original Type 1 lever handle, the following proposal offers a similar lever dimension, provides a contemporary solution with a visual link back to the original 1970's aluminium lever handles, whilst also being DDA compliant. This proposal also provides a close match to one of the earlier ad hoc aluminium lever handle replacements used within the 3<sup>rd</sup> floor corridor area (fig 3 & 4).



Fig .3. Ad Hoc Later Addition



Fig .4. Ad Hoc Later Addition



Original Type 1 lever handle



Proposed Replacement Ironmongery



#### PROPOSED CONTEMPORARY ALTERNATIVE

This contemporary alternative offers both visual and dimensional similarities to the original Type 1 lever handle and provides a close match to the later addition aluminium lever handle (fig .3. & .4.), providing a simple clean line solution.

- Lever handle in grade 304 satin stainless steel.
- DDA compliant.

*See appendix A for full details*

A separate matching grade 304 satin stainless steel lock escutcheon would be fitted below

*See Appendix B for details*

#### STATEMENT OF JUSTIFICATION

The following issues have been considered during the preparation and development of the proposals.

- The importance of the building and its intrinsic architectural and historic interest on both a national and local level

The building forms part of the University of London campus which is an important and recognisable local landmark within Camden and which is recognised nationally. The building has architectural associations with Denys Lasdun, as mentioned earlier and within the accompanying Heritage Statement.

The replacement flush panel doors replicate the original doors removed, whilst providing greater fire protection for both building occupancy and use.

The proposals will not impact on the grade II\* listed buildings intrinsic architectural or historical interest.

- Setting and contribution to the local scene

The elements of the proposed works will have a positive impact on the interior of the building but will not impact on the buildings setting and contribution to the local scene.

- Substantial benefits to the community

The proposed works are such that they will not bestow any additional benefits to those already provided to the local community or economic regeneration of the area.

The maintenance and repair of the building however illustrates the continued investment and care by the SOAS of a locally important building.

## APPENDIX A

Steelworx SWL Zurigo Lever on Rose  
Grade 304 Satin Stainless Steel Finish

## Steelworx SWL Zurigo Lever on Rose

SWL1133SSS

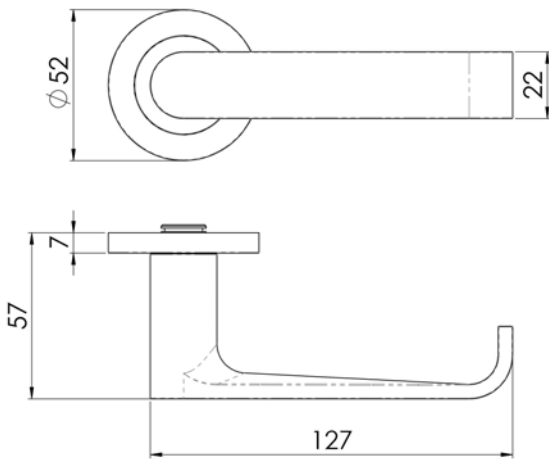

Lever on a concealed fix threaded rose. A straight bold faced lever with a rounded return to door end for safety. Part of the Steelworx range in grade 304 Stainless Steel. Comes with a 10 year mechanical guarantee and is Fire door rated.





APPENDIX B  
Steelworx SWL Escutcheon for Oval Lock Cylinder  
Grade 304 Satin Stainless Steel Finish

## Steelworx SWL Escutcheon

SWL102

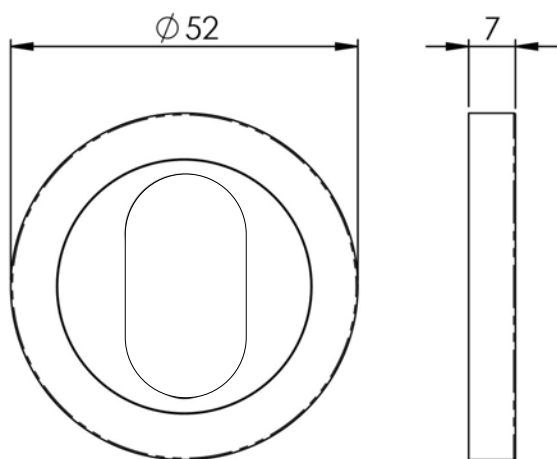

A concealed fix escutcheon with a threaded screw on outer rose to match the SWL Levers. Euro profile and Lock version available in SSS, BSS, BSS/SSS Duel, Satin PVD and Matt Black Finish. Part of the Steelworx range in grade 304 Stainless Steel. Fire door rated.

