

Window 1
Elevation

Window 1
Section AA

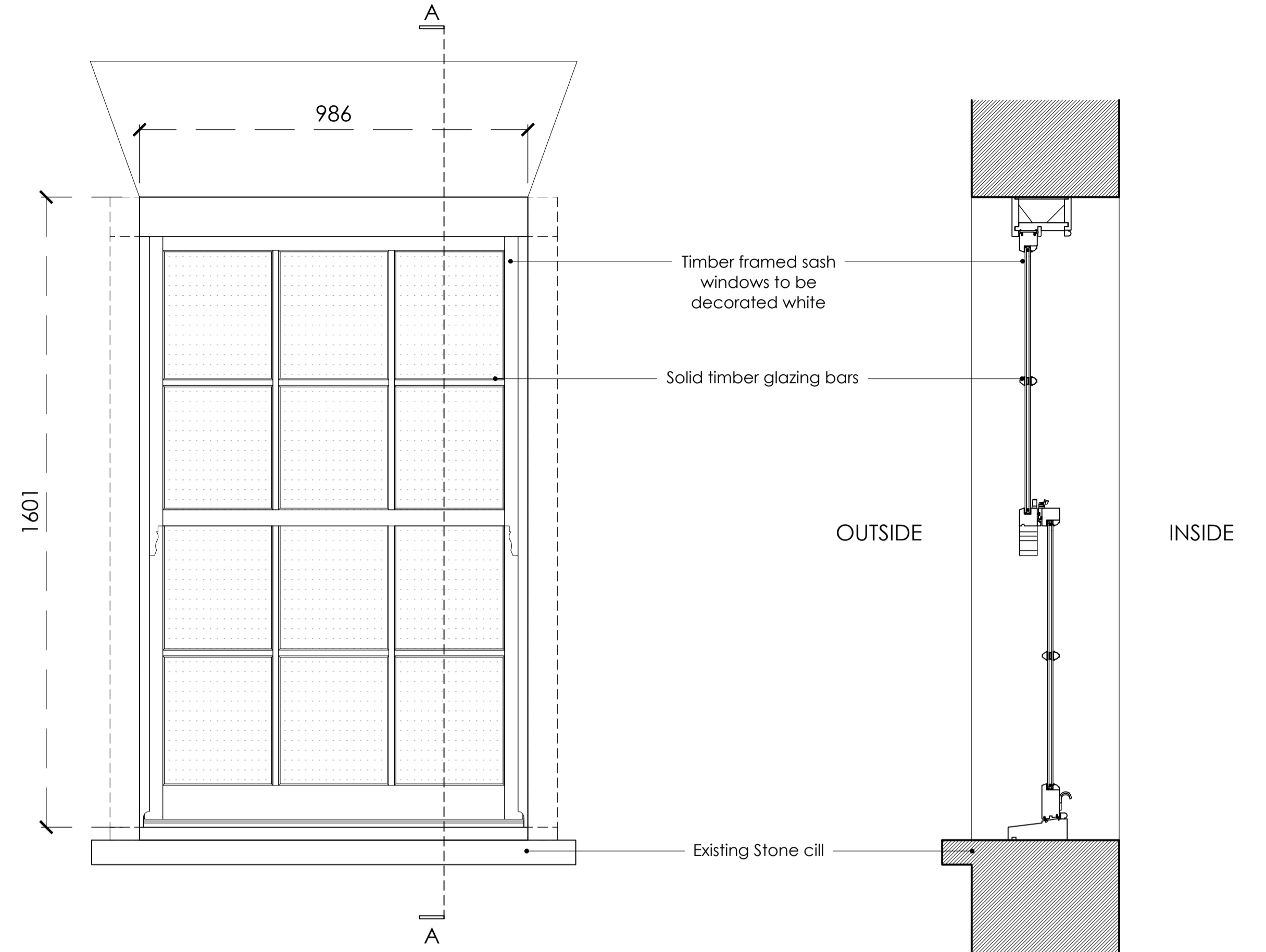

Window 2
Elevation

Window 2
Section AA

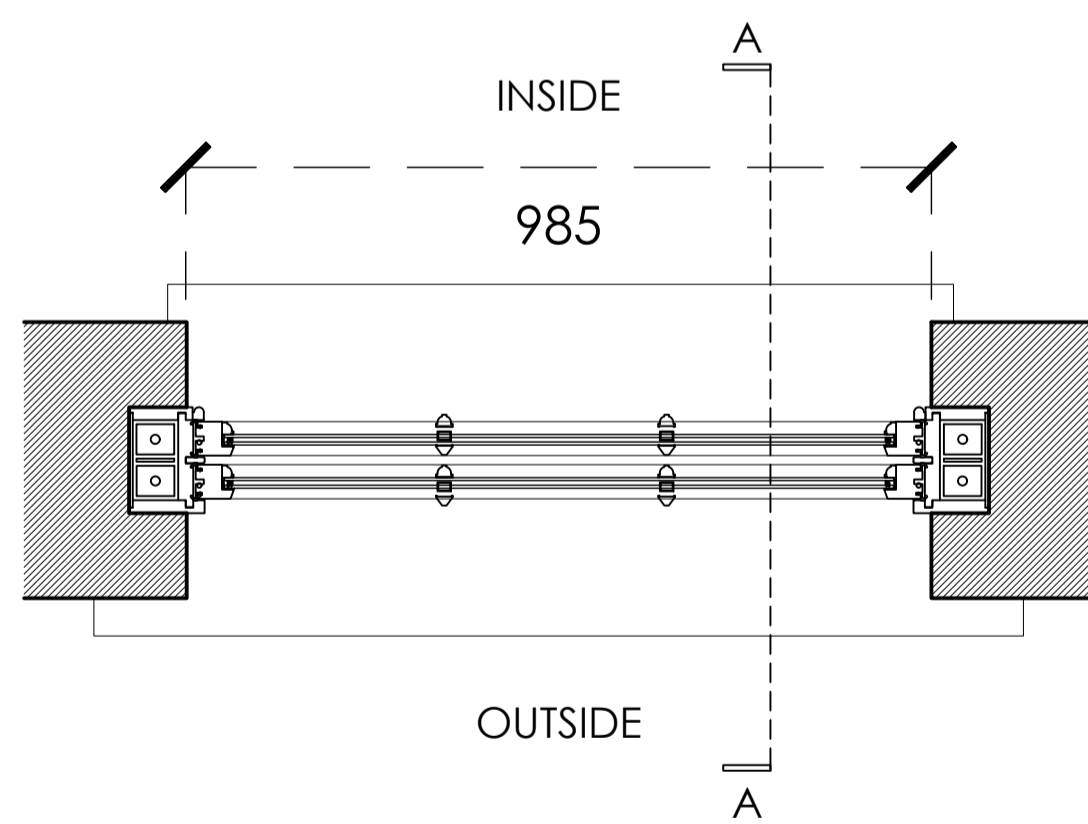

Window 1
Plan

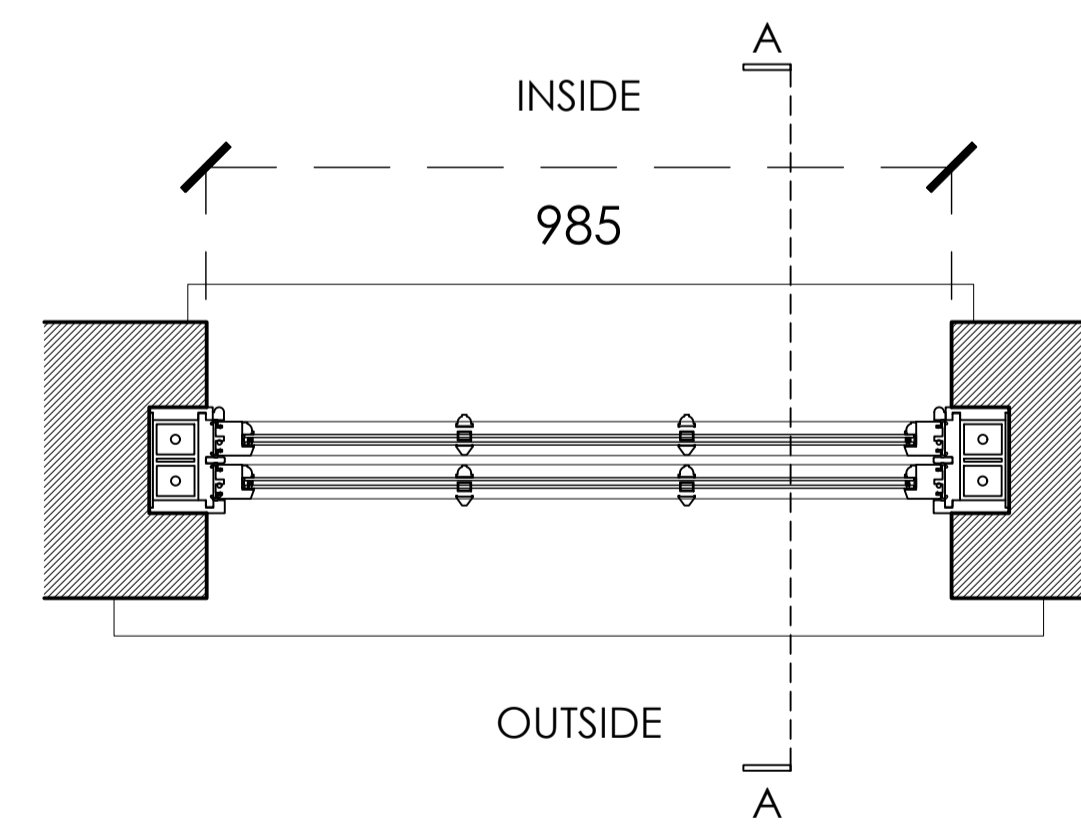

Window 2
Plan

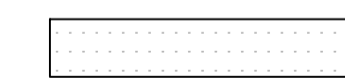
 Glazing

rev. date details
 -- 2024.08.02 first issue TC MLR
 drawn by checked by

District.

Studio 4 . 17-19 Blackwater Street . London . SE22 8SD
 020 7871 3101
 studio@districtarchitects.co.uk
 www.districtarchitects.co.uk
 this drawing is copyright .

Planning	Proposed
project	Window Details 1
client	115 Kings Cross Road Camden . London . WC1X 9NH Wicklow Projects for and on behalf of Loromah Estates
job no . 074 .	(3) stage . 1 type / place . 501 series / number
	-- revision

scale bar . do not scale from this drawing . scale bar is included as a requirement of statutory approvals only
 note to contractor_use only figured dimensions for construction