

**Storers**  **COLD ROOM CONDENSER INFORMATION (Standard)**

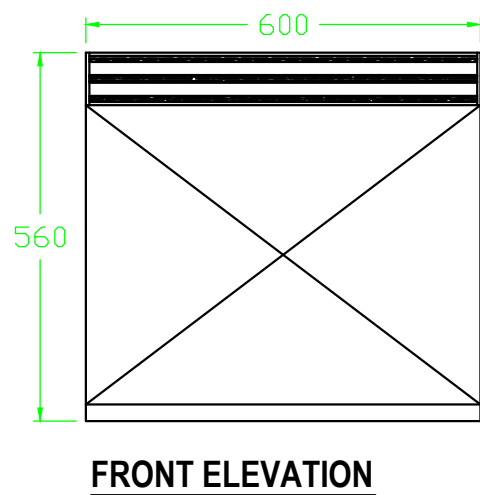
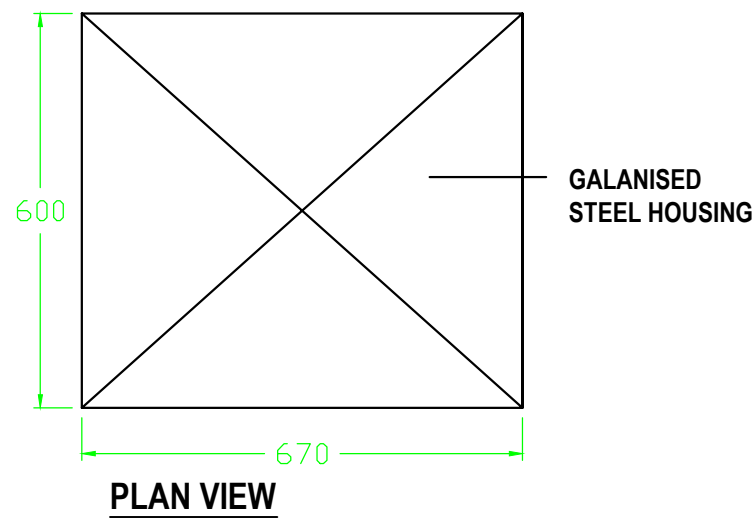
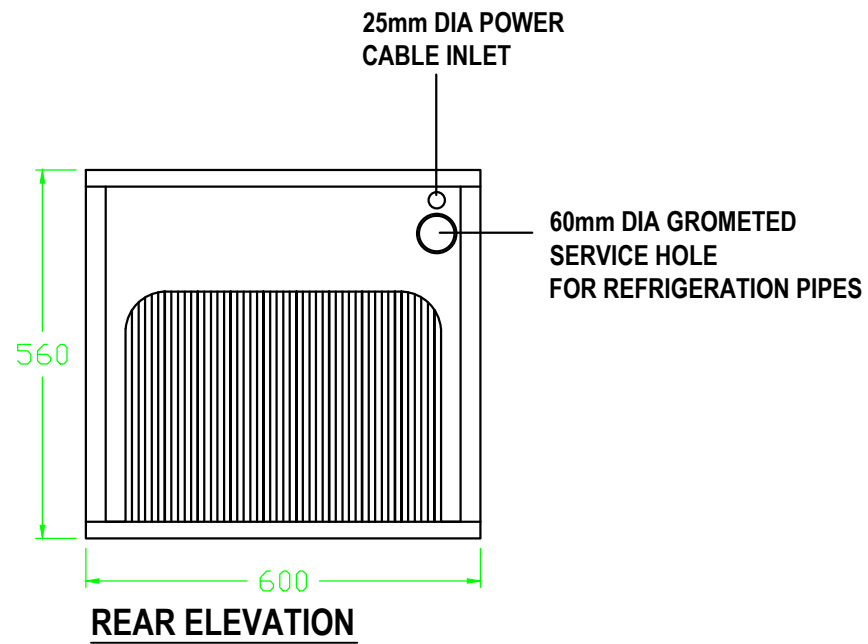

**UNIT INFORMATION**

NOISE LEVELS - 33DB @ 10m (WITH NORMAL UNIT HOUSING)  
THESE LEVELS ARE BASED ON MAXIMUM FIGURES AND MAY VARY LOWER IN DIFFERENT SITE CONDITIONS

HEAT OUTPUT - 2 - 2.5 KW

AIR FLOW - 500 - 800 CUBIC FEET PER MINUTE

WEIGHT OF CONDENSER UNIT - 45KG

THE CONDENSER UNIT CAN EITHER BE WALL MOUNTED OR ALTERNATIVELY IT CAN BE PLACED DIRECTLY ON THE FLOOR OR FLAT ROOF RESTING ON AN ANTI-VIBRATION PAD.

PLEASE ALLOW A SPACE OF AT LEAST 700mm X 700mm FOR THIS CONDENSER UNIT

