

STAGE -1

1. EXCAVATE MAX. 0.80m BELOW GROUND LEVEL.
2. INSERT AND FIX 1st LEVEL FRAME @ 0.1m BELOW GROUND LEVEL.
3. INSERT 2nd LEVEL FRAME IMMEDIATELY BELOW 1st LEVEL FRAME & MOVE DOWN WITH EXCAVATION.

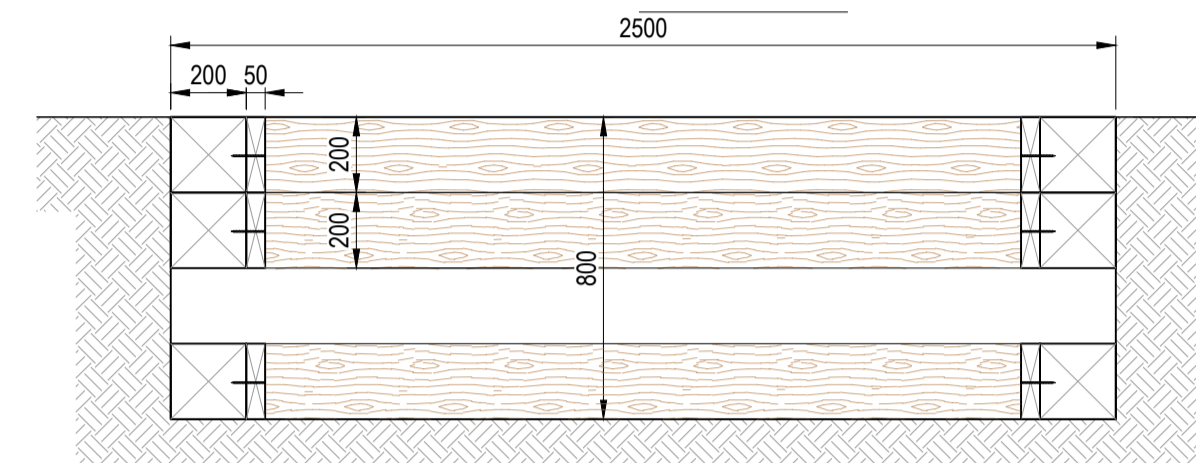

STAGE -2

1. EXCAVATE FURTHER 200 MOVING BOTTOM LEVEL FRAME DOWN WITH EXCAVATION & FIXING THIS FRAME @ 200MM AWAYS FROM 2nd LEVEL FRAME.
2. INSERT 3rd LEVEL FRAME IMMEDIATELY BELOW 2nd LEVEL EXCAVATE FURTHER 200mm AND DROPPING LAST FRAME WITH EXCAVATION

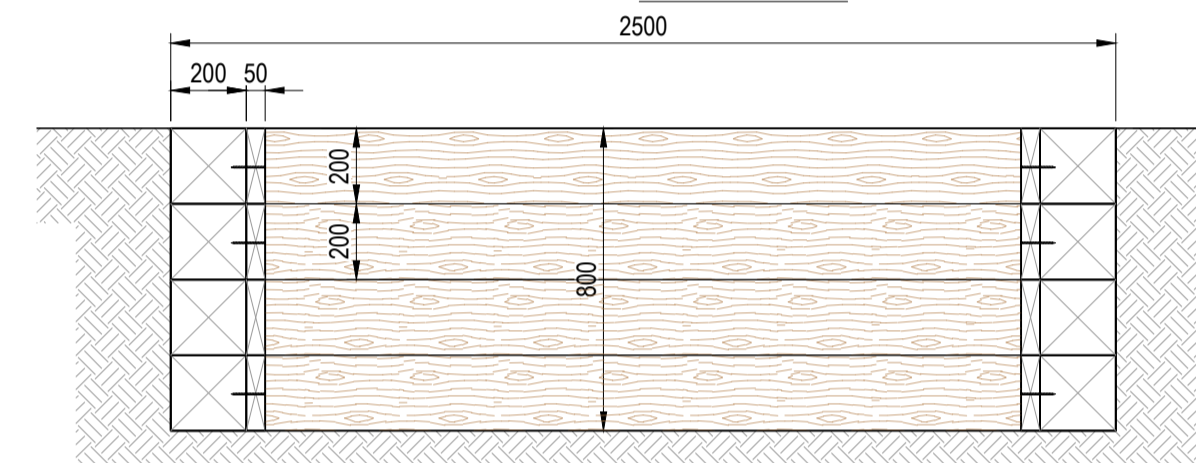

STAGE -3

1. 1st PHASE OF EXCAVATION COMPLETED AND TIMBER WALERS ARE IN PLACED

NOTE: REST OF THE SHAFT OF EXCAVATION AND TIMBER WALERS, STRETCHERS INSTALLATION SIMILAR TO 1st PHASE UNTIL IT IS REACH LAST STAGE AS SHOWN BELOW

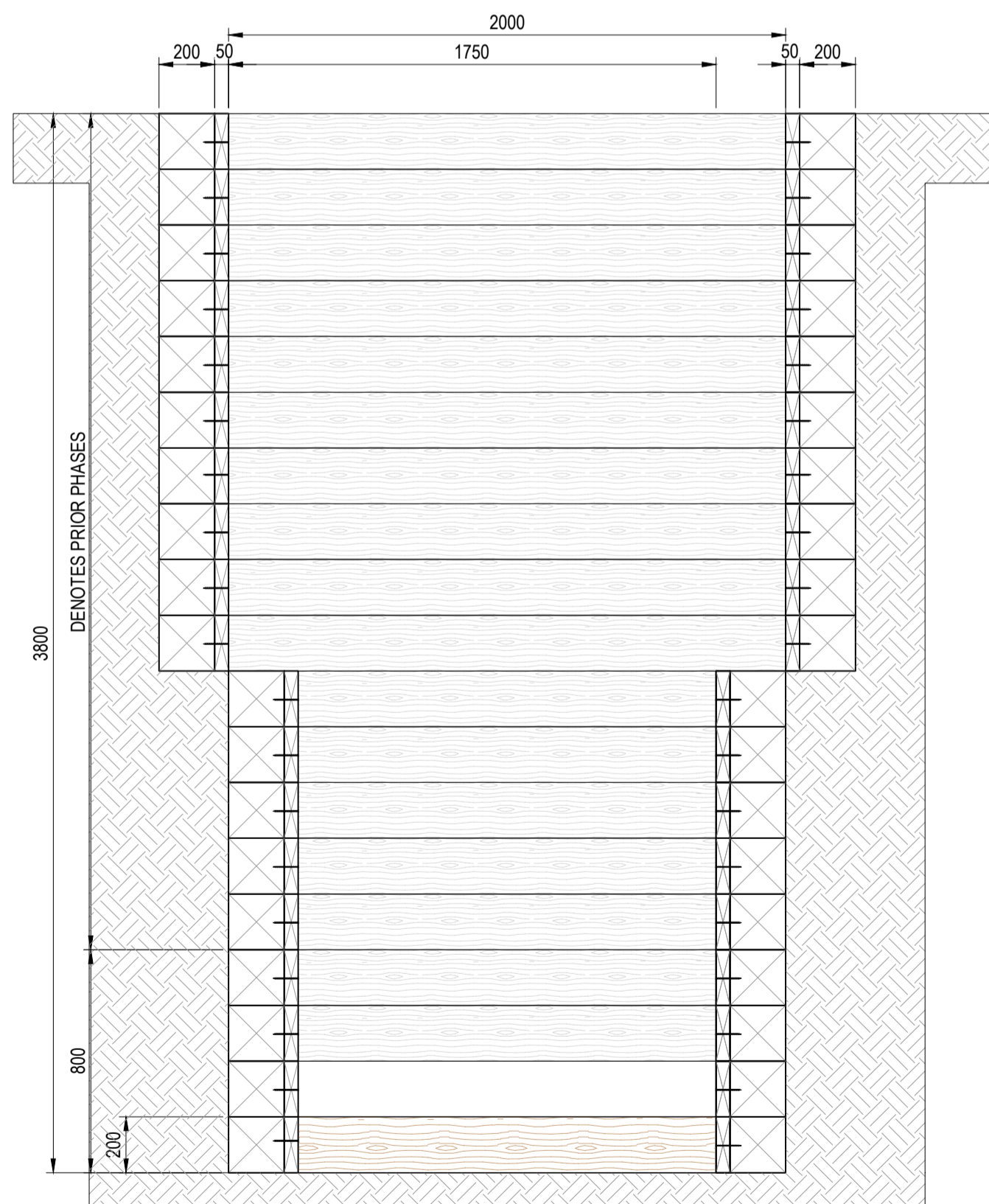

REMANING LAST PHASE

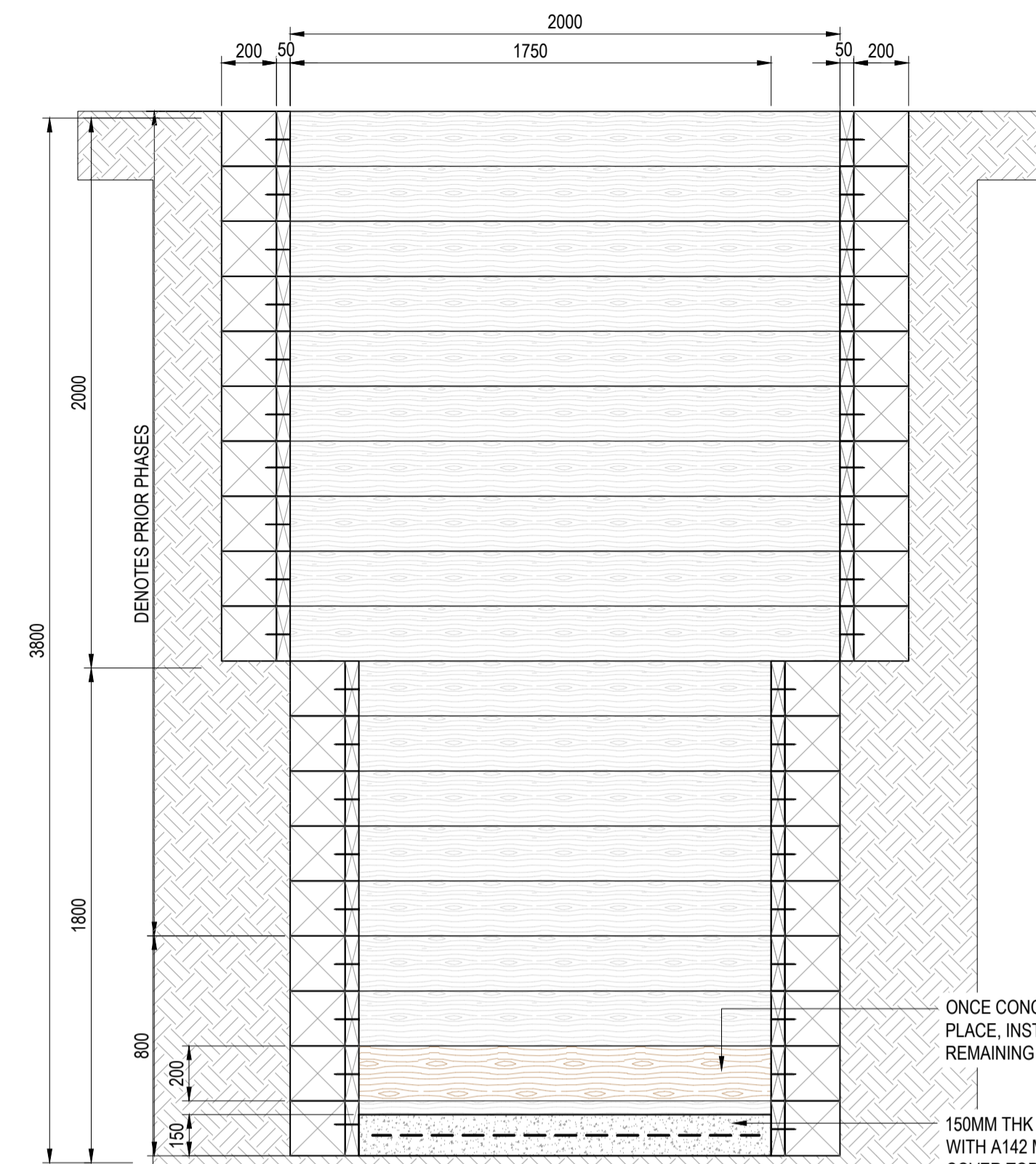

FINAL STAGE / SHAFT COMPLETION

THIS DRAWING TO BE READ IN CONJUNCTION WITH STRUCTURAL CALCULATION AND DRAWINGS NO 1001, 1002 & 1004

NOTE:-
ALLOW FOR GROUTING IF SOIL WAS FOUND TO BE POOR.

GROUT:-
PUMP CEMENTITIOUS GROUT TO FILL VOIDS BEHIND THE FRAMES (FOR SHAFTS)/BOARDS TO PROVIDE STABILITY TO THE MADE GROUND/CLAY AS THE EXCAVATION PROGRESSES.

NOTES:-
1. SHAFT MUST BE EXCAVATED IN 200mm-400mm INCREMENTS & FRAMES TO BE INSTALLED IN CLOSE BOARDED MANNER.
2. THE GROUND ON THE SIDES OF THE SHAFT MUST BE GROUTED AFTER INSTALLATION OF EVERY TWO FRAMES. THIS IS TO STABILISE THE SOIL UNDER THE FOUNDATION

SHAFT LOADING	
• SURCHARGE	20.0 kN/m ²
SINGLE STOREY FOUNDATION LOADING	
• SURCHARGE ON FOOTING	131.0 kN/m ²
SOIL TAKEN AS	
• MADE GROUND	:0.00m-1.20m
• SANDY CLAY	:1.20m-3.00m
• FIRM CLAY	:3.00m-3.80m

EXCAVATED SOIL TO BE KEPT MINIMUM 10m AWAY FROM THE SITE.

IT IS ASSUMED THAT
 • NO GROUND WATER
 • NO SCAFFOLDING LOAD
 • NO OTHER LOAD EXCEPT AS MENTIONED
 ALL LEVELS SHOWN ARE APPROX. TBC ON SITE

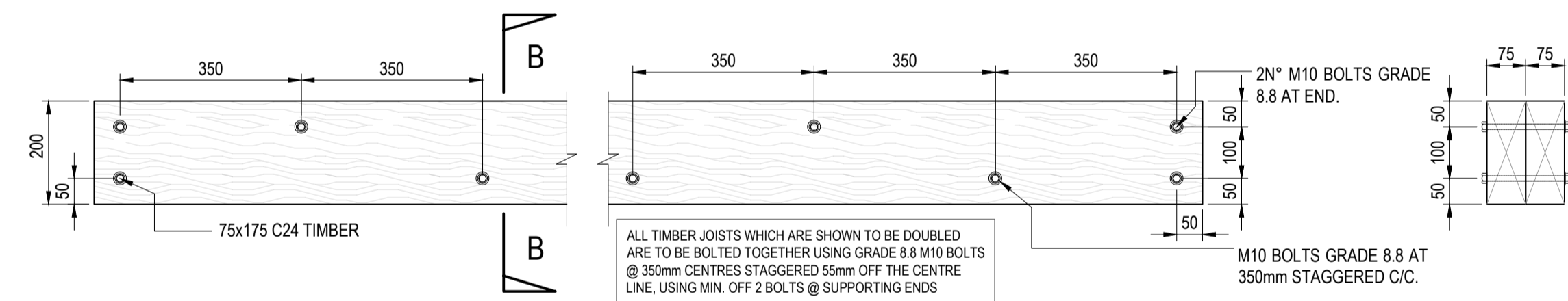

ALTERNATIVE OPTION : TYPICAL DOUBLE-UP WALERS

ALL TIMBER JOISTS WHICH ARE SHOWN TO BE DOUBLED ARE TO BE BOLTED TOGETHER USING GRADE 8.8 M10 BOLTS @ 350mm CENTRES STAGGERED 55mm OFF THE CENTRE LINE, USING MIN. OFF 2 BOLTS @ SUPPORTING ENDS

M10 BOLTS GRADE 8.8 AT 350mm STAGGERED C/C.

GENERAL NOTES

1. ALL DIMENSIONS AND LEVELS ARE TO BE DETERMINED AND OR CHECKED BY THE CONTRACTOR ON SITE. SHOULD ANY DISCREPANCY BE IDENTIFIED BETWEEN THE DIMENSIONS, AND OR DETAILS DETERMINED ON SITE, AND THOSE SHOWN THOSE SHOWN ON THE RELEVANT DRAWINGS, THE ENGINEER SHALL BE NOTIFIED IMMEDIATELY, AND HIS INSTRUCTIONS OBTAINED PRIOR TO THE COMMENCEMENT OF THE WORK.
2. THE CONTRACTOR SHALL BE RESPONSIBLE FOR THE DESIGN AND IMPLEMENTATION OF ALL TEMPORARY WORKS OTHER THAN THOSE DETAILED, AND THE SAFETY AND STABILITY OF THE NEW WORKS AND ADJACENT STRUCTURES DURING CONSTRUCTION.
3. WHERE A PRODUCT IS SPECIFIED TO BE OBTAINED FROM A MANUFACTURER OR SUPPLIER, THE CONTRACTOR SHALL INSTALL THE PRODUCT IN ACCORDANCE WITH THE INSTRUCTIONS SUPPLIED BY THE MANUFACTURER. SHOULD THERE BE ANY VARIATION BETWEEN THE BETWEEN WORK SPECIFIED ON THE DRAWINGS AND THE MANUFACTURER'S INSTRUCTIONS, THE CONTRACTOR SHALL REFER THE MATTER TO THE ARCHITECT FOR INSTRUCTION BEFORE PROCEEDING.
4. ALL DIMENSIONS ARE IN MILLIMETRES, UNLESS NOTED OTHERWISE.
5. DRAWINGS ARE NOT TO BE SCALED.

GROUND MOVEMENT

TEMPORARY WORKS FOR THE SHORING OF EXCAVATIONS WILL ALWAYS RESULT IN SOME GROUND MOVEMENTS (BOTH LATERAL AND SETTLEMENT) BEHIND THE SHORING.

1. ENSURE ALL VOIDS ARE COMPREHENSIVELY INFILLED CONTINUOUSLY AS THE SHAFT IS DRIVEN.

INSTALLATION

IT IS CLIENT'S RESPONSIBILITY TO DEVELOP A SAFE SYSTEM IF WORK FOR THE INSTALLATION AND USE OF THE EQUIPMENTS. DESIGN IS STANDARD BASED UPON TYPICAL DESIGN. ANY SITE-SPECIFIC HAZARDS IDENTIFIED BY THE CLIENT SHOULD FORM THE BASIS OF THEIR RISK ASSESSMENTS AND SAFE SYSTEM OF WORK THAT IS NECESSARY FOR SAFE EXECUTION OF THE WORKS.

2. IF IN DOUBT REPORT IT TO DESIGNER FOR THEIR COMMENTS.

SITE SPECIFIC NOTES

- WATER LEVEL AS SHOWN, IF ANY FOUND
- ENSURE ALL HOLES/SHAFTS ARE PROTECTED FROM RAIN.
- ALL DIMENSIONS, LEVELS ETC TO BE VERIFIED/CONFIRMED BY CONTRACTOR. ANY DISCREPANCIES TO BE NOTIFIED TO THE ENGINEER.
- AVOID POSSIBLE RISK OF MOVEMENT TO EXISTING FOUNDATIONS BY KEEPING FRAMES TIGHT AGAINST THE OPENING WITH NO GAP, AND SHOULD NOT BE LEFT LOSE ANYTIME.
- CONTRACTOR TO TAKE SPECIAL CARE DURING EXCAVATION NOT TO DISTURB UNDERGROUND PIPES AND CABLES. EXTRA CARE TO BE TAKEN WHILE WORKING NEAR FOOTINGS.
- BACKFILL SHAFT USING LEAN MIX CONCRETE IN LINE WITH UTILITY COMPANY REQUIREMENTS FOR SERVICES FOUND. THIS TO LIMIT ANY MOVEMENT OF THE EXISTING BUILDING.
- CONTRACTOR TO MONITOR THE MOVEMENTS IN THE WALLS NEAR THE SHAFT/HEADING BEFORE AND DURING THE WORKS.
- CONDITION SURVEY TO BE CARRIED OUT BEFORE AND AFTER TO MONITOR MOVEMENTS/CRACKS IF ANY
- LEAVE SITE CLEAN AND TIDY.

SURVEYS & INVESTIGATIONS

1. BEFORE COMMENCING WORK THE CONTRACTOR SHALL CARRY OUT AN EXTERNAL CONDITION SURVEY OF THE EXISTING BURIED STRUCTURES AND SERVICES INCLUDING RECORD PHOTOGRAPHS.
2. THE CONTRACTOR SHALL EXCAVATE THE GROUND IN SELECTED LOCATIONS TO ESTABLISH THE EXISTING BURIED STRUCTURES AND SERVICES.

TIMBER NOTES

1. ALL TIMBER SHALL STRENGTH CLASS SC 4/C24 U.N.O.
2. ALL STRUCTURAL TIMBER INCLUDING WEDGES IS TO BE TREATED BY PROTIM PREVAC IN ACCORDANCE WITH BS 5268 - PART 5 HAZARD CATEGORY 'C' AND IN STRICT ACCORDANCE WITH THE MANUFACTURERS RECOMMENDATIONS.
3. TEMPORARY TIMBER WEDGES TO BE USED FOR ADJUSTMENT OF TIMBER STRUTS.

CO2	15/02/24	SHAFT AMENDED	MAK	M.R
CO1	31/01/24	ISSUED FOR CONSTRUCTION	MAK	M.R
REV	DATE	DESCRIPTION	BY	APP

PROJECT: 5 HOLLY MOUNT, NW3 6SG

TITLE: SEQUENCE OF WORKS

CLIENT: J BROWNE CONSTRUCTION CO LTD



DRAWN: MAK	CHECKED: SA	APPROVED: M.R
PROJECT NUMBER: 24483	DATE: 31/01/2024	SCALE @ A1: AS SHOWN
STATUS DESCRIPTION: FOR CONSTRUCTION		STATUS: A

DRAWING NUMBER: JBR - MWP - 00 - XX - DR - C - 1003	REV: C02
---	----------