

- NOTES:**
DO NOT SCALE FROM THIS DRAWING.
- THIS DRAWING TO BE READ IN CONJUNCTION WITH KJ TAIT MECHANICAL SPECIFICATION, THE ARCHITECTS DIMENSIONED LAYOUTS AND ALL OTHER RELEVANT CONTRACT DOCUMENTATION.
 - ALL PLANT AND EQUIPMENT SHALL BE INSTALLED, REGULATED AND TESTED IN ACCORDANCE WITH THE MANUFACTURERS PRINTED INSTRUCTIONS.
 - ALL INTERNAL HEATING AND CHILLED WATER PIPEWORK TO BE CARBON STEEL PIPEWORK TO BS 1387 THERMALLY INSULATED WITH FOIL FACE 'CLASS O' INSULATION AND ALUMINIUM HAMMER CALD PROTECTIVE CASING.
 - AUTOMATIC AIR VENTS SHALL BE FITTED ON ALL SYSTEM HIGH POINTS AND MANUAL DRAIN COCKS ON SYSTEM LOW POINTS.
 - ALL PIPEWORK PENETRATIONS THROUGH FIRE RATED STRUCTURES OR BARRIERS TO BE SUITABLY FIRE RATED.
 - ALL VALVES TO BE FULLY ACCESSIBLE AND PROVIDED WITH IDENTIFICATION LABELS.
 - THE CONTRACTOR SHALL ALLOW FOR TESTING COMMISSIONING AND SETTING TO WORK ALL HEATING, CHILLED WATER AND VENTILATION SYSTEMS IN ACCORDANCE WITH THE RELEVANT CIBSE COMMISSIONING CODES AND THE BSRIA APPLICATION GUIDES.
 - THE MECHANICAL CONTRACTOR SHALL BE RESPONSIBLE FOR THE COORDINATION OF THEIR WORKS WITH ALL OTHER TRADES.

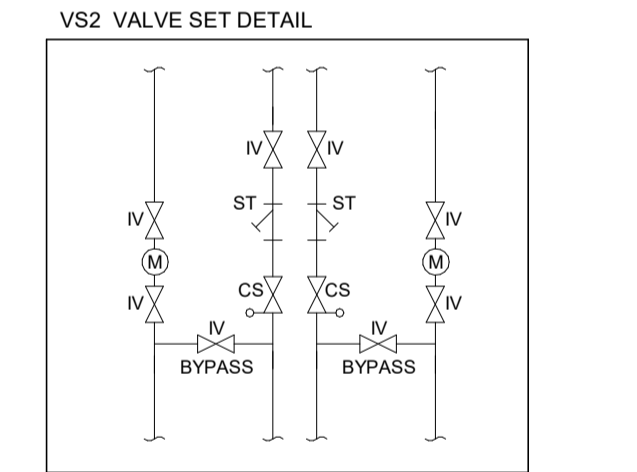
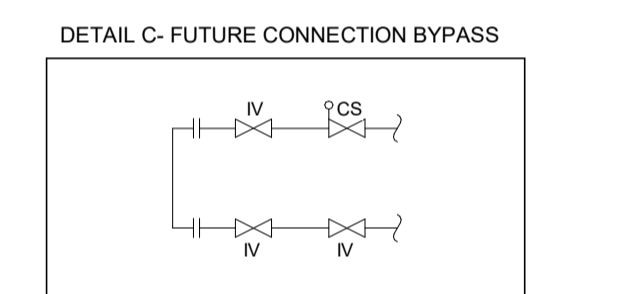
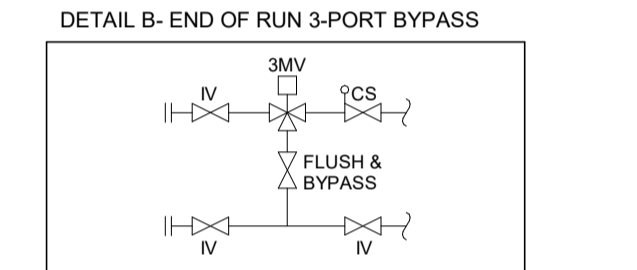
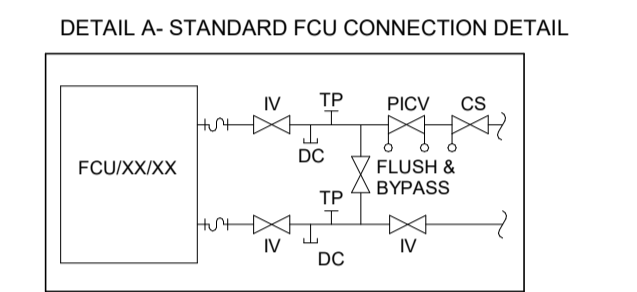
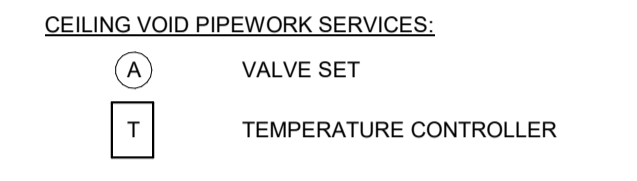
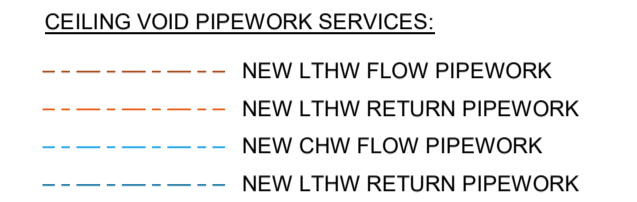

S4-P01	26/01/2024	STAGE 3 CAT-B ISSUE	TE	AG
SUIT-REV	DATE	DESCRIPTION	DRN	CHK
3				

STAGE 3

THIS DRAWING IS COPYRIGHT. DO NOT SCALE FROM DRAWING. THE CONTRACTOR AND THEIR SUB-CONTRACTORS ARE TO VERIFY ALL DIMENSIONS ON SITE BEFORE MAKING SHOP DRAWINGS OR COMMENCING MANUFACTURE.

KJ TAIT
ENGINEERS

1 Fitzroy Square
London W1T 5HF
T +44 (0) 207 388 0952
E london@kjtait.com
W www.kjtait.com

PROJECT INFORMATION			
CLIENT	OXFORD VICTORIA HOUSE DEVELOPMENT LTD LONDON, WC1B 4DA		
PROJECT	MECHANICAL SERVICES 5TH FLOOR HTG & COOLING LAYOUT SHEET 1 of 2		
DRAWING INFORMATION			
DESIGNED BY	TE	DATE	JAN 2024
DRAWN BY	MZ	KJT JOB No.	L3221
SCALE	1 : 100 @ A1	ORIGIN-VOL-LEVEL-TYPE-ROLE-CLASS NUMBER	S4 - P01