

**ELEVATION**  
Scale: 1:2 @A1

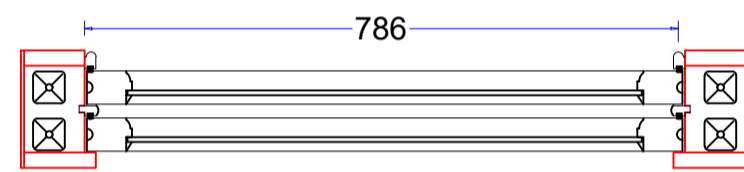

**PLAN SECTION**  
Scale: 1:3 @A1

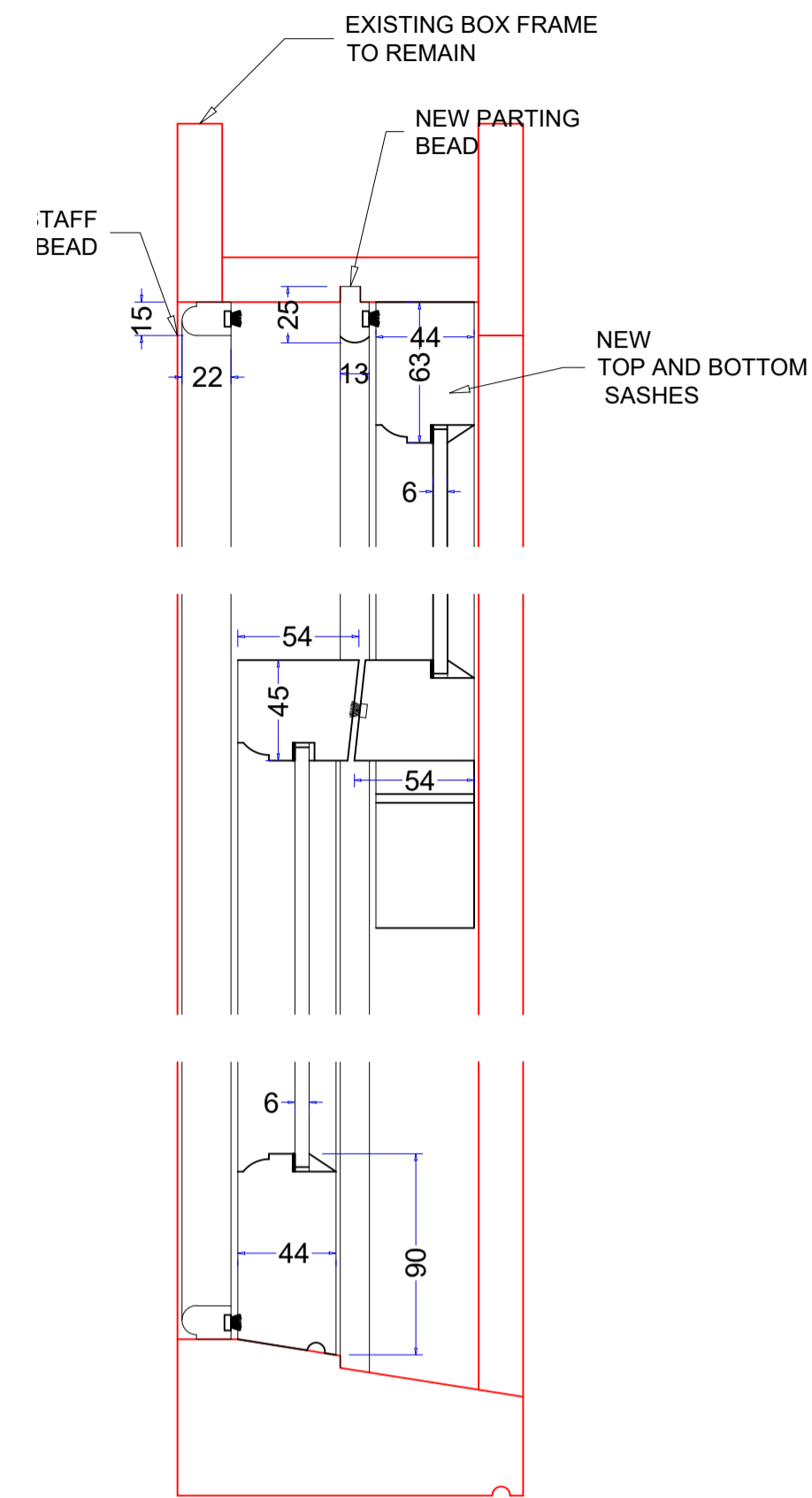

**HEIGHT SECTION**  
Scale: 1:3 @A1

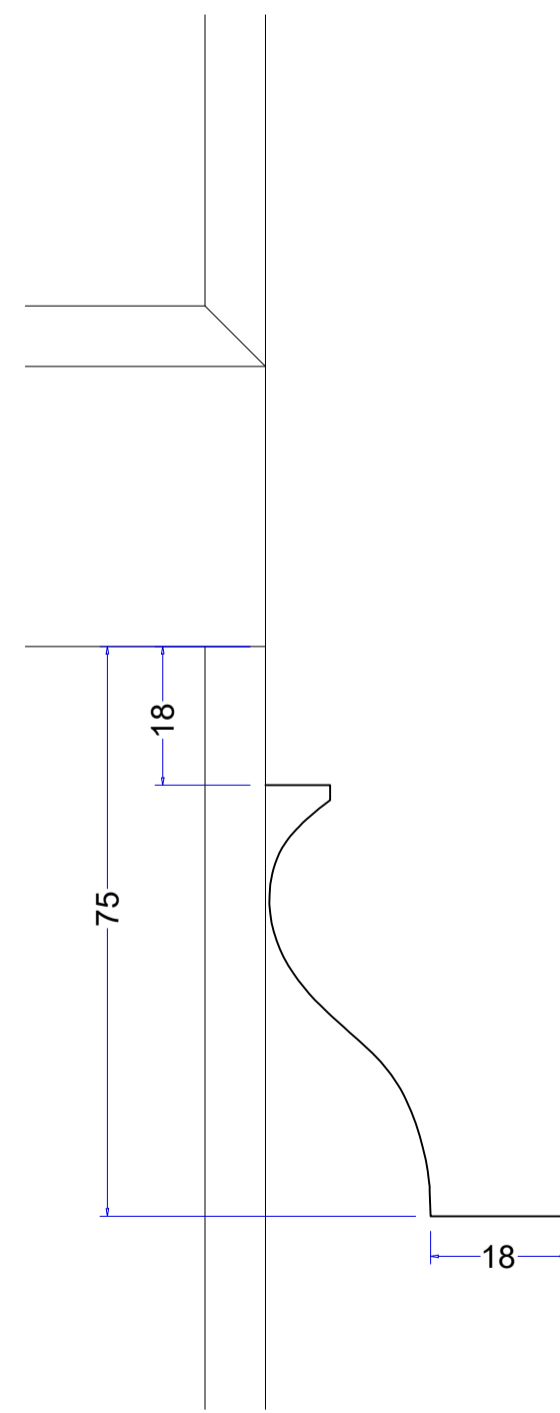

**HORN DETAIL**  
Scale: 1:1 @A1

DATE	REVISION & NOTES
	<ul style="list-style-type: none"> <li>TO SUPPLY AND INSTALL NEW SASHES/ PARTING AND STAFF BEADS INTO EXISTING BOX FRAMES.</li> <li>ALL TO BE MANUFACTURED FROM SCANDINAVIAN SOFTWOOD</li> <li>GLAZED WITH 6.4mm CLEAR LAMINATED GLASS</li> <li>FINISH- VARNISHED ON THE INSIDE AND PAINTED EXTERNALLY TO MATCH THE EXISTING.</li> </ul>

05/09/23	REV 01: REDUCED SIZE
----------	----------------------

Within all our quotations allowance has been made to prepare drawings for each item ordered, we have also included one revision per drawing. Any subsequent revisions will be chargeable.

- NOTES ON DRAWINGS**
- ALL DRAWINGS ARE FROM AN EXTERNAL POINT OF VIEW UNLESS OTHERWISE STATED.
  - THIS DRAWING IS SOLELY PREPARED FOR THE USE OF K&D JOINERY IN PREPARATION OF THEIR WORK AND MUST NOT BE USED FOR ANY OTHER PURPOSE.
  - DOUBLE PIPES AND CASIMENTS WITH A VERTICAL GLASSOM WILL ALLOW A TINY AMOUNT OF LIGHT LEAKAGE AT THE TOP AND BOTTOM OF THE DOORS & SASHES.
  - CHECK THERE IS SUFFICIENT ACCESS THROUGH AROUND THE BUILDING SUITABLE FOR THE SIZE OF JOINERY INDICATED ON THIS DRAWING.
- NOTES ON SIZES**
- WE CANNOT GUARANTEE THE STABILITY OF ANY DOOR OVER 2000mm HIGH & RECOMMEND ALL DOORS OVER 2000mm HIGH TO BE HINGLED & 6% BUTTE HINGES.
  - WOOD IS A NATURAL PRODUCT THAT RESPONDS TO TEMPERATURE AND HUMIDITY VARIATIONS BY EXPANDING AND CONTRACTING. MOVEMENT SHOULD BE EXPECTED DURING THE DIFFERENT SEASONS THROUGHOUT THE YEAR. K&D JOINERY CANNOT BE HELD RESPONSIBLE FOR NATURAL MOVEMENT IN TIMBER AND ANY FUTURE ADJUSTMENTS FOLLOWING DELIVERY/INSTALLATION OF PRODUCTS WILL BE CHARGED FOR. IF YOU REQUIRE A COMPLETELY STABLE PRODUCT WITH NO MOVEMENT WE HIGHLY SUGGEST USING ACCOYS TIMBER.
- NOTES ON FINISHING**
- K&D JOINERY DO NOT RECOMMEND FINISHING EXTERNAL JOINERY IN BLACK OR A SIMILAR DARK COLOUR AND CANNOT OFFER ANY GUARANTEES DUE TO THE TIMBER BECOMING MORE SUSCEPTIBLE TO MOVEMENT, TWISTING, WARPING, CRACKING DUE TO THE DARKER COLOUR ABSORBING MORE HEAT.
  - ALL JOINERY WILL BE PRIMED WHITE UNLESS OTHERWISE SPECIFIED.
  - COLOR VARIATION CAN BE EXPECTED WHEN USING CLEAR STAINED FINISHES, ESPECIALLY WHEN THE JOINERY IS MADE OUT OF BIRCH AND OAK.
  - ALL CLEAR FINISHES EXTERIOR JOINERY SHOULD BE TREATED ON A YEARLY BASIS FOLLOWING PROFESSIONAL GUIDELINES.
- NOTES ON VENTILATION**
- PLEASE NOTE, TRICKLE VENTS WILL NOT BE FITTED TO JOINERY UNLESS SPECIFIED BY THE CLIENT. WE CANNOT DETERMINE THE VENTILATION REQUIREMENTS.
- NOTES ON MOISTURE CONTENT**
- THE MOISTURE CONTENT OF THE TIMBER TO BE USED WILL BE 10% ± 1 (EXTERNAL)
  - THE MOISTURE CONTENT OF THE TIMBER TO BE USED WILL BE 10% ± 1 (INTERNAL)
- NOTES FOR WORKSHOP**
- END GRAIN SEALER TO BE USED ON ALL EXPOSED END GRAIN, INCLUDING THE ENDS OF BEADING.
- NOTES FOR SITE CARE AFTER DELIVERY**
- APPROVAL OF THIS DRAWING CONFIRMS THAT YOU WILL REVIEW AND ADHERE TO THE SITE CARE INFORMATION SHEET ATTACHED WITH THIS DRAWING.

**KEY:**

<span style="color: red;">■</span> = SURVEY SIZES	<span style="color: green;">■</span> = REBATE SIZES
<span style="color: blue;">■</span> = JOINERY SIZES	<span style="color: magenta;">■</span> = DATUM SIZES

READ IN CONJUNCTION WITH THE FOLLOWING DRAWINGS  
XXXX-XXX to XXX-XXX INCL.  
ANY ARCHITECTS DRAWING  
XXXXXXXXXXXXXXXXXX

ISSUED FOR APPROVAL

K&D

BESPOKE JOINERY

JOINERY HOUSE      020 8526 7031  
69 CHEQUERS LANE      INFO@KANDD.ORG  
DAGENHAM RM9 6QJ      KANDD.ORG

CLIENT: JONATHAN AND CAROLINE LANE  
PROJECT: 46 HIGHGATE WEST HILL N6 6DB  
DESCRIPTION: REPLACEMENT SASHES  
JOB N6: -----  
SCALE: SEE DRAWING @ A1  
DWG N6: 6139  
REV: 00  
DWG BY: AK  
DATE: 28/03/24