

ELEVATION A-A

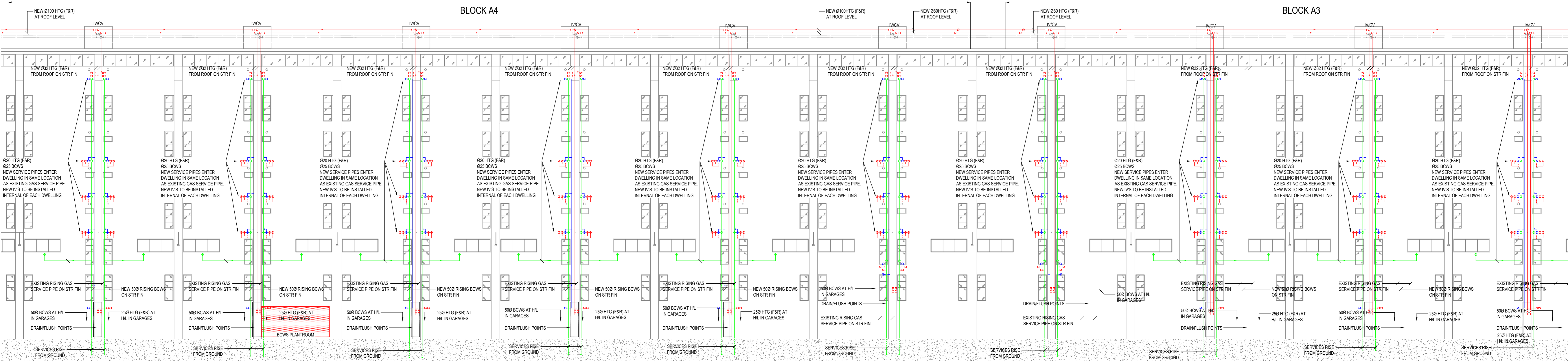

ELEVATION A-A

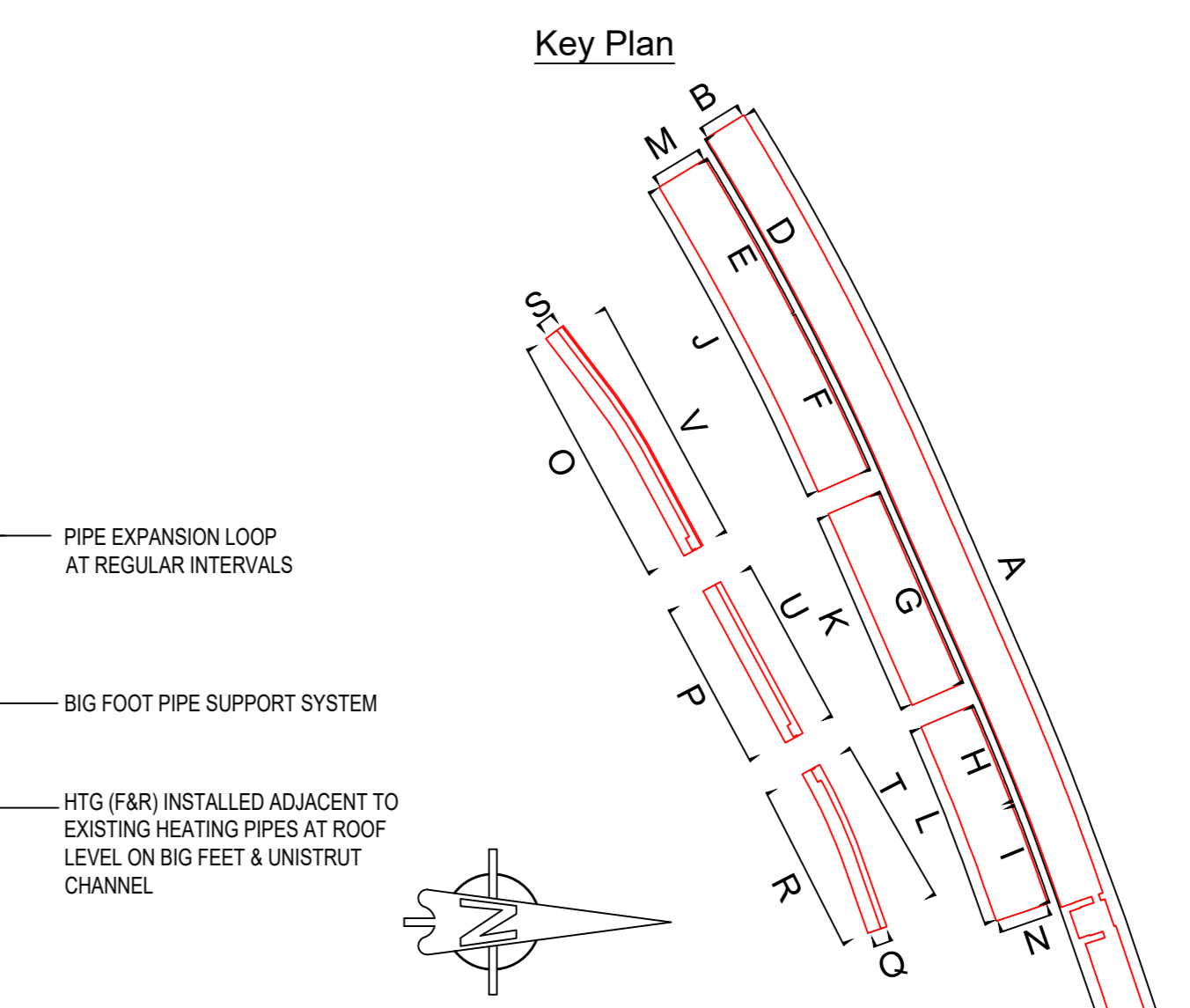

NOTES
1. ALL PIPEWORK FULLY INSULATED AND WEATHER PROTECTED WITH P.I.B. AND STUCCO ALUMINIUM CLADDING.

DRAWING LEGEND
 - - - EXISTING GAS SERVICE PIPE
 - - - NEW BOOSTED COLD WATER PIPE
 - - - NEW HEATING FLOW & RETURN PIPE

B	BUILDING BACKGROUND UPDATED	TDS	DM	21/02/2024
A	BOWS PLANT ADDED	TDS	DM	20/01/2024
REV	AMENDMENT	DRN	CHK	DATE
Client Camden ARGYLE STREET LONDON WC1H 8NJ				
BYA BUTLER & YOUNG ASSOCIATES Mechanical and Electrical Consulting Engineers 1st Floor, 54-62 Station Road East, Oxley, Surrey RH9 0PG Telephone 01883 717172 Fax 01883 717174 Website www.bya.co.uk Email enquiries@bya.co.uk				
Project ALEXANDRA ROAD ESTATE (ROWLEY WAY)				
Drawing Title PROPOSED REPLACEMENT HTG & DOM WATER SERVICES PIPE ROUTE TO EXTERNAL ELEVATION OF DWELLINGS (A1-A5)				
Scales	1:100	Xref	-	Drawn Sheet
Drawn	NS	Checked	JS	Date NOV 23
BYA Ref	3547	Drawing Number	3547-RW-M-519	REV
BYA Contract	3547-RW-M-519			B

PLANNING DRAWING