

01 Elevation as Existing
1000 1:20 @ A3

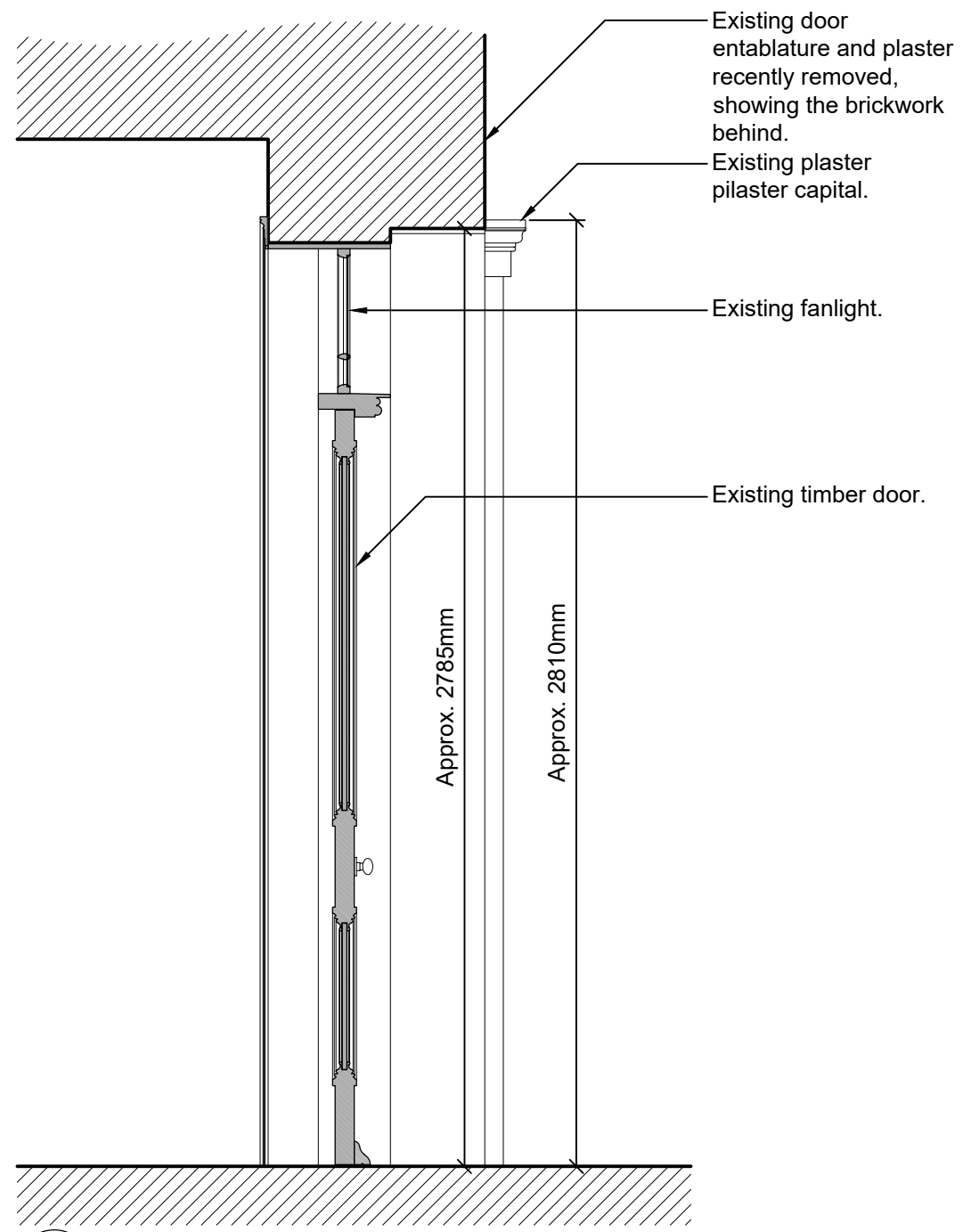

03 Section as Existing
1000 1:20 @ A3

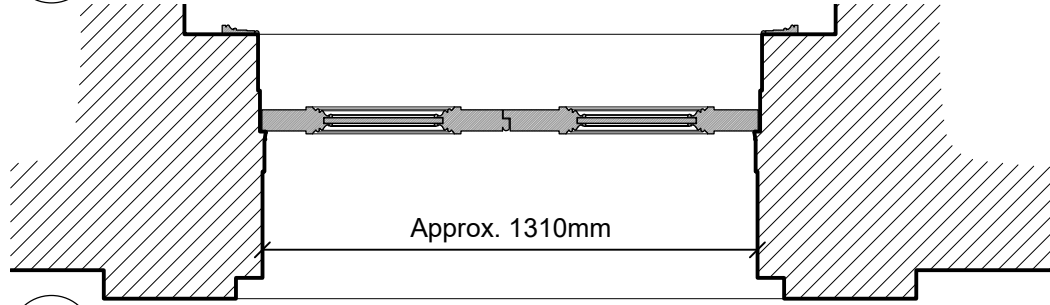

02 Plan as Existing
1000 1:20 @ A3

General Notes:

- Drawing not for construction.
- Drawing to be printed in colour.
- Drawing to be read in conjunction with all other associated documentation.
- Architect to be informed of any discrepancy in writing.



04 Front Door as Existing
1000 NTS @ A3



05 Plaster Capital as Existing
1000 NTS @ A3

Purpose of Issue:
FOR_LBC

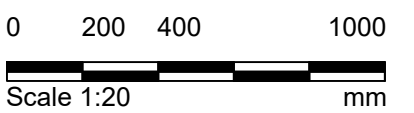

Notes

1. Any dwg format drawing is to be read in conjunction with and at the scale of the accompanying pdf.
2. Where colours other than black or grey are used, the drawing must be plotted in colour.
3. For status 'C' (Construction) drawings all dimensions are to be checked on site by the contractor, scaling is for Local Authority purposes only.
4. Unless otherwise indicated, all dimensions are in millimeters.
5. All information on this drawing is to be read in conjunction with the relevant Donald Insall Associates specification and trade contractors' drawings and information by specialists.
6. In the event of any discrepancy, please contact us immediately.
7. This drawing may contain survey information by others and is to be used solely for the purposes for which it was issued.
8. These are uncontrolled documents issued for information purposes only. If you have any queries regarding the drawings, please contact DIA immediately.
9. Please note DIA cannot be held responsible for any errors arising from changes made to an uncontrolled dwg file.

Drawing Status		Rev		Date		Dwn		Auth		Revision	
F	Feasibility										
S	Sketch Design										
P	Planning										
B	Building Control										
D	Design Development										
M	Measurement										
T	Tender										
C	Construction										
R	Record										
		0	27-02-24	JHH	MXV	Issue for Listed Building Consent					
		Rev	Date	Dwn	Auth	Revision					

Donald Insall Associates
Chartered Architects and Historic Building Consultants

12 Devonshire Street
London W1G 7AB
(+44) 020 7245 9888
london@insall-architects.co.uk

31 Pond Street, London

Project	PDS31	No	1000
Scale (A3)	1:20	Status	3P
		Revision	0

Front Door Details
As Existing