

EXISTING WINDOW TYPE 1  
SCALE 1:15

DETAILS 1, 2 & 3  
SCALE 1:2



Tel: 020 8017 1632  
info@londonsash.com  
The London Sash Window Company  
41 High Street, London SE20 7HJ

DO NOT SCALE THIS DRAWING. USE FIGURE DIMENSIONS

NOTES:

- A) Timber: Scandinavian redwood (softwood).
- B) Glass: 4mm clear float glass fitted with heritage putty.
- C) Paint Colour: RAL 9016.
- D) Internal "OVOLO" mould.
- E) Bottom rail – 94mm.
- F) Meeting rail – 38mm.
- G) Top rail – 53mm.
- H) Staff bead – 15mm x 25mm.
- I) Parting bead – 7mm x 25mm.
- J) Brighton fastener
- K) Sash lifts
- L) Rola lock – Key operated

CLIENT:	Robert East
LOCATION:	NW3 1HS
SCALE:	Drawing scale @A2
DRAWN BY:	TB
DATE	09 February 2024
DRAWING TITLE:	Existing Window Type 1
DRAWING NUMBER:	Exis_Win_Type 1
PURPOSE OF ISSUE:	For Planning
QUANTITY:	5
REVISION:	A

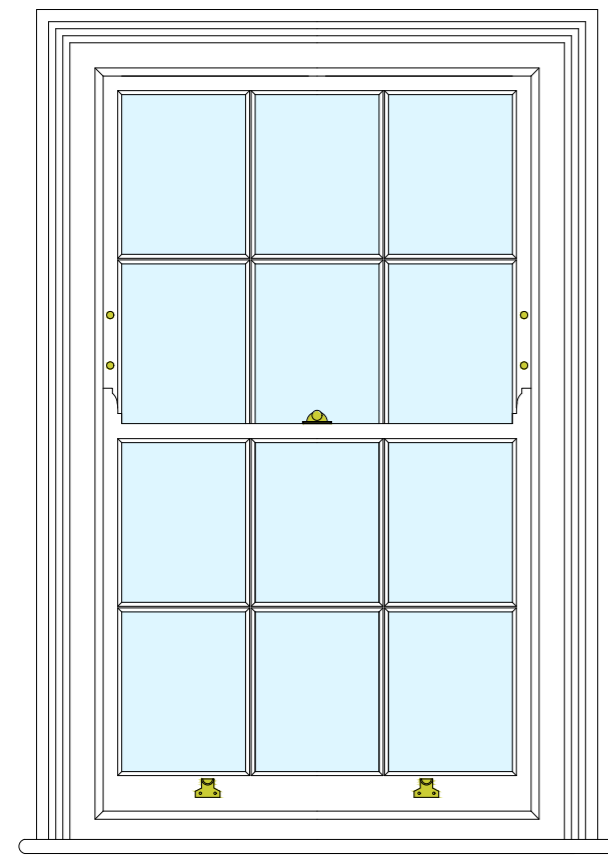

INTERNAL ELEVATION

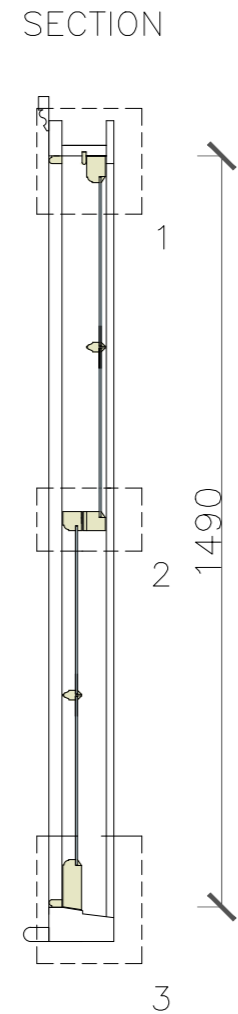

SECTION

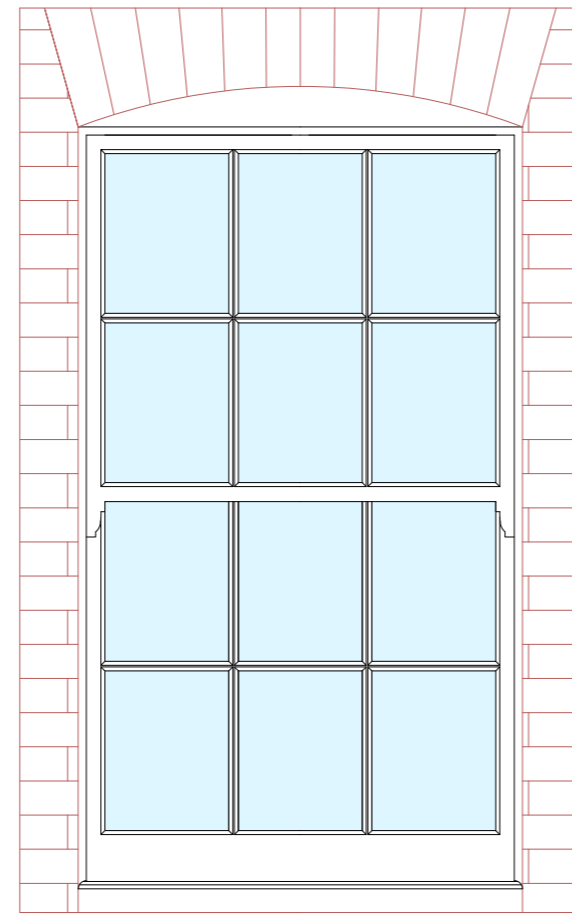

EXTERNAL ELEVATION

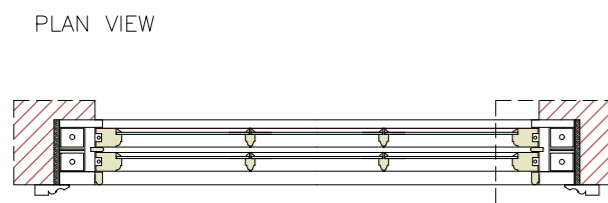

PLAN VIEW

4

DETAIL 4  
SCALE 1:2

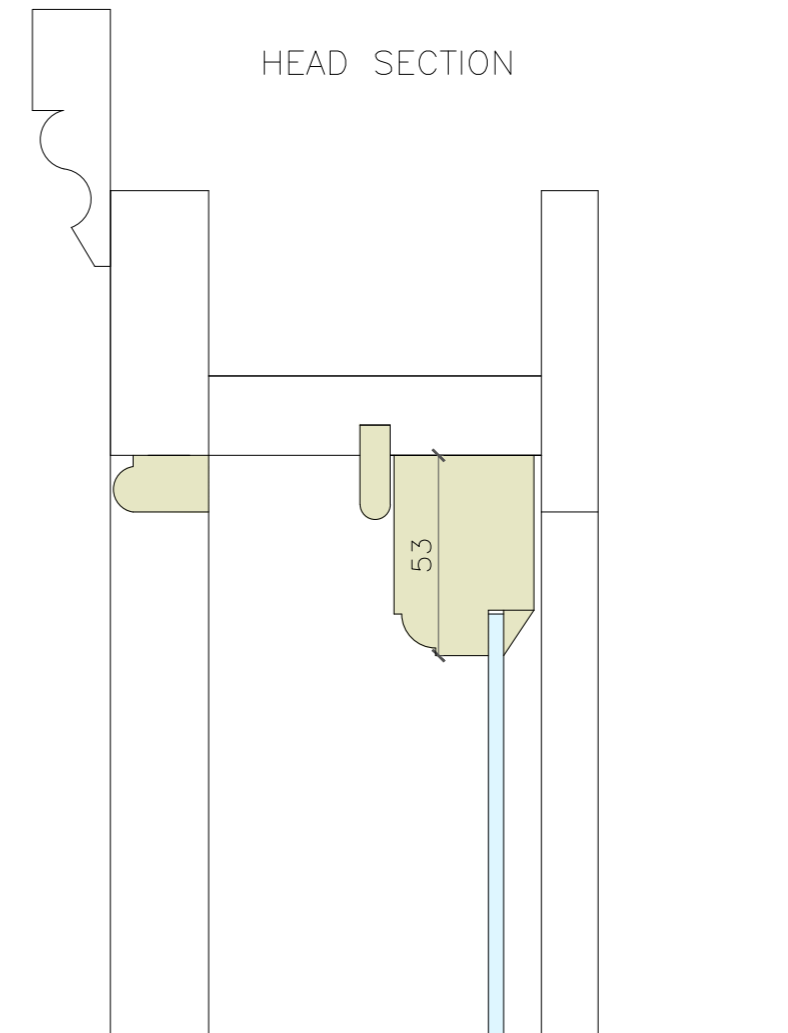
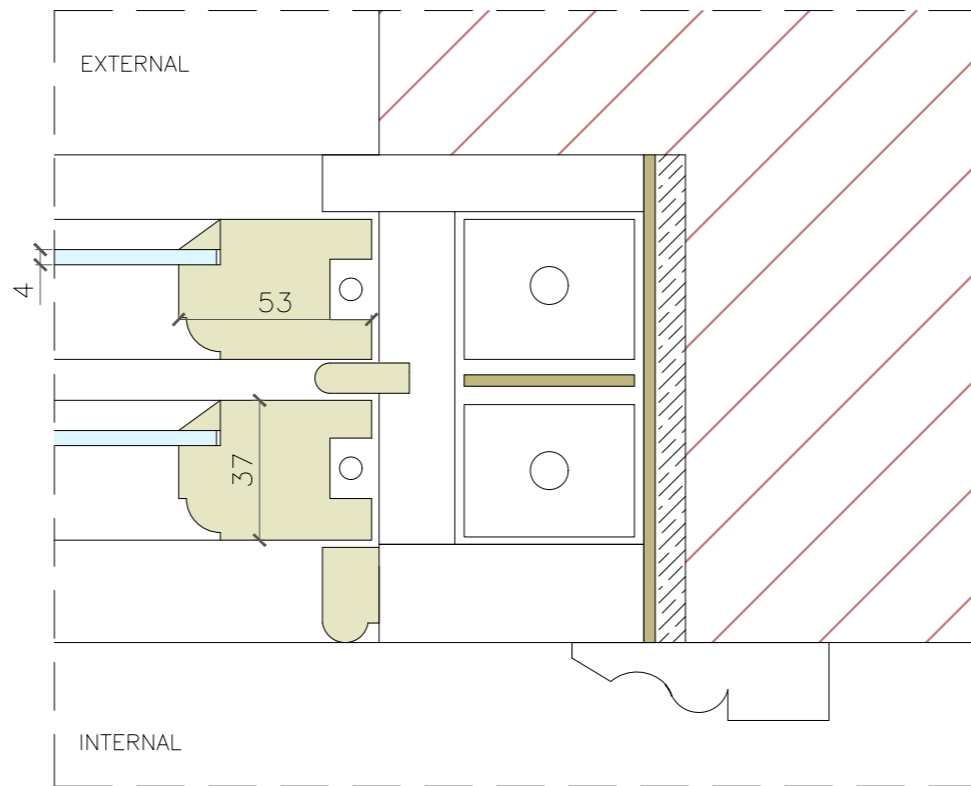

HEAD SECTION

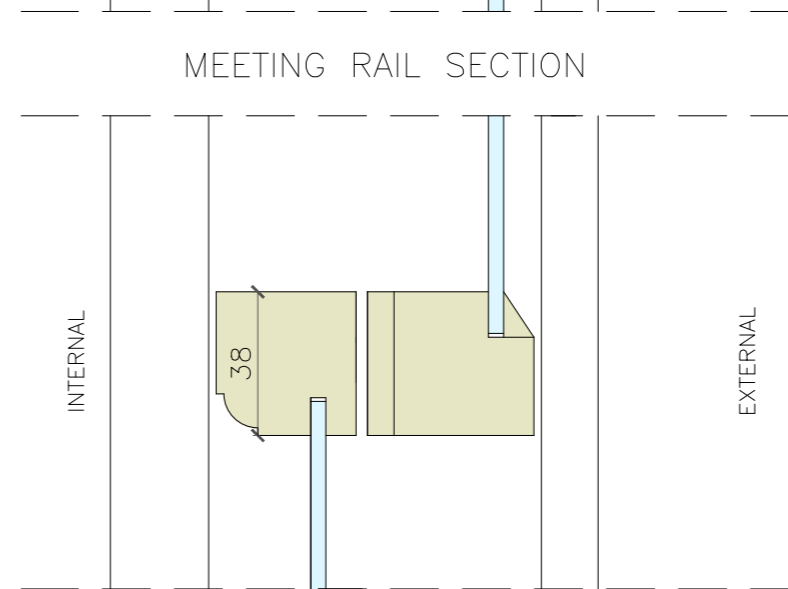

MEETING RAIL SECTION

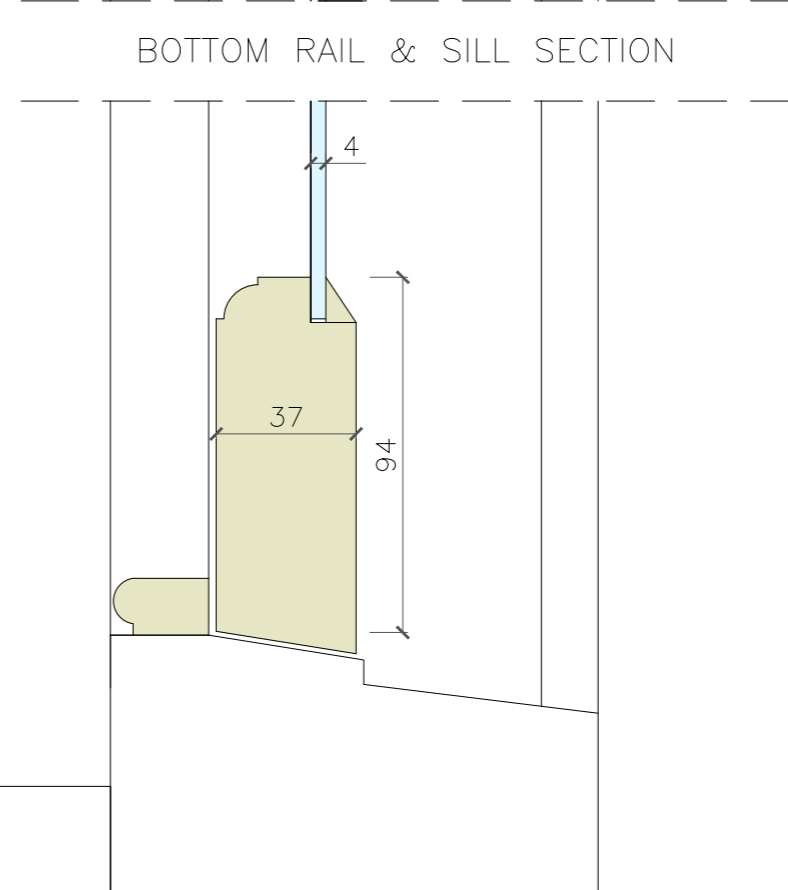

BOTTOM RAIL & SILL SECTION

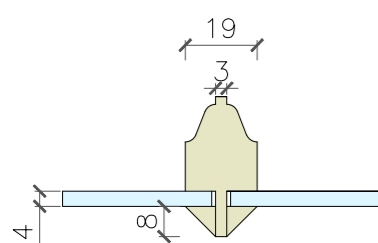

GLAZING BAR

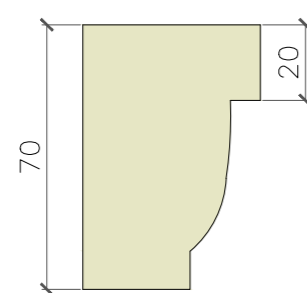

SASH HORN

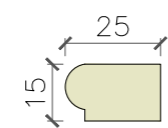

STAFF BEAD



PARTING BEAD

ITEMS DETAIL  
SCALE 1:2

PROPOSED WINDOW TYPE 1  
SCALE 1:15

DETAILS 1, 2 & 3  
SCALE 1:2



Tel: 020 8017 1632  
info@londonsash.com  
The London Sash Window Company  
41 High Street, London SE20 7HJ

DO NOT SCALE THIS DRAWING. USE FIGURE DIMENSIONS

NOTES:

SASHES INTO EXISTING FRAME

- A) Timber: Accoya
- B) Glass: 4mm Low-e glass to internal pane.  
6mm warm edge spacer bar, argon filled.  
4mm clear float glass to external pane.
- C) Paint Colour: RAL 9016.
- D) Internal "OVOLO" mould.
- E) Bottom rail – 94mm.
- F) Meeting rail – 38mm.
- G) Top rail – 53mm.
- H) Staff bead – 15mm x 25mm.
- I) Parting bead – 7mm x 25mm.
- J) Draught exclusion weather seal.
- K) Brighton fastener
- L) Sash lifts
- M) Rola lock – Key operated

CLIENT:	Robert East
LOCATION:	NW3 1HS
SCALE:	Drawing scale @A2
DRAWN BY:	TB
DATE	09 February 2024
DRAWING TITLE:	Proposed Window Type 1
DRAWING NUMBER:	Pro_Win_Type 1
PURPOSE OF ISSUE:	For Planning
QUANTITY:	5
REVISION:	A

HEAD SECTION

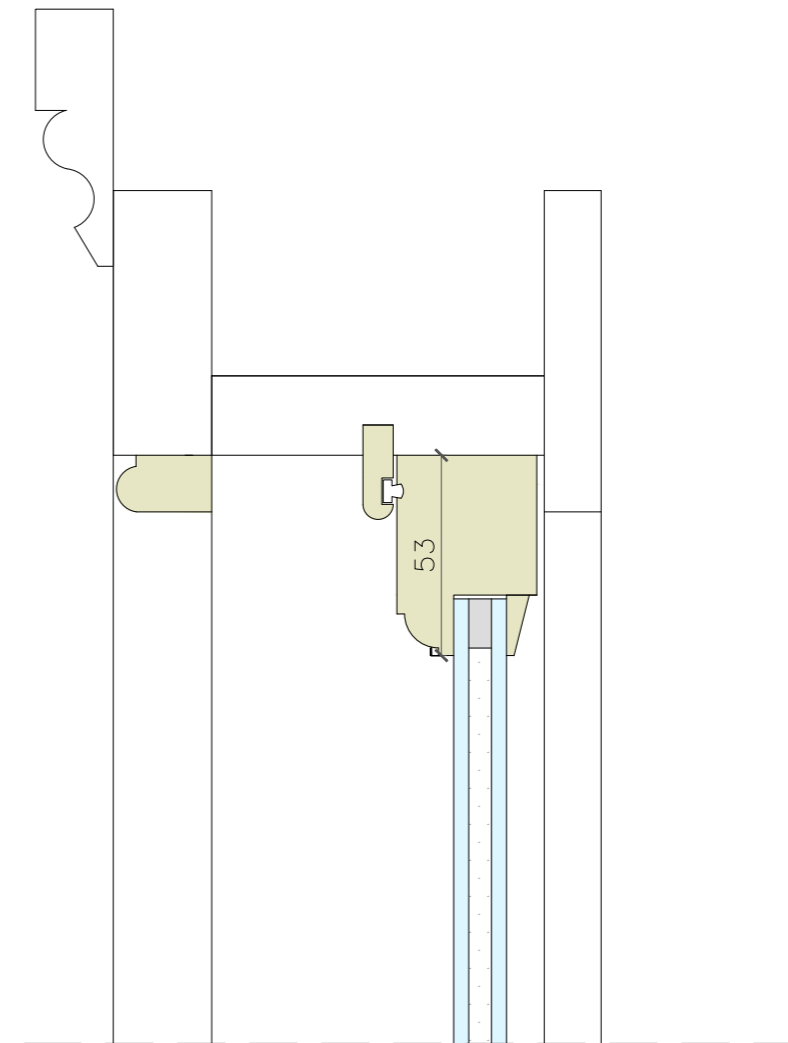

MEETING RAIL SECTION

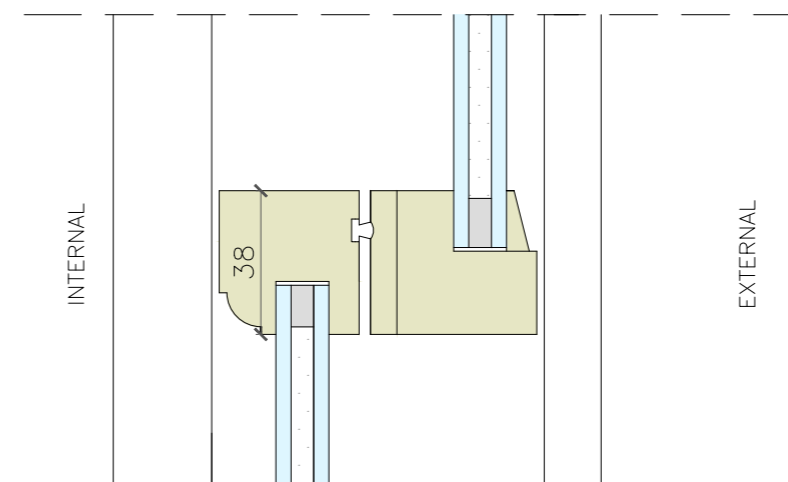

BOTTOM RAIL & SILL SECTION

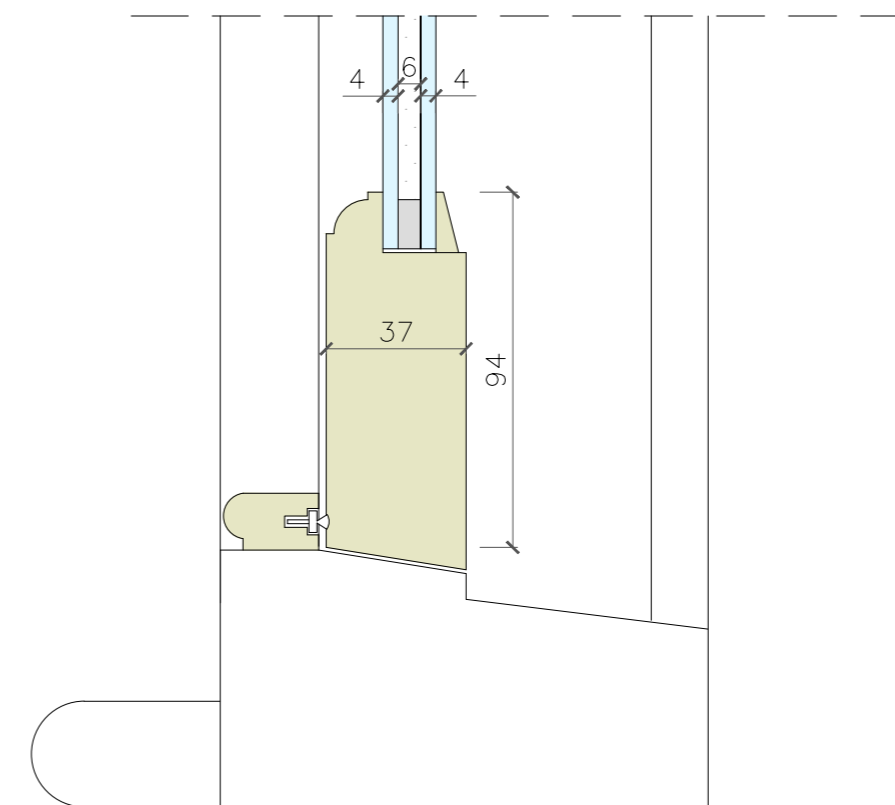

SECTION

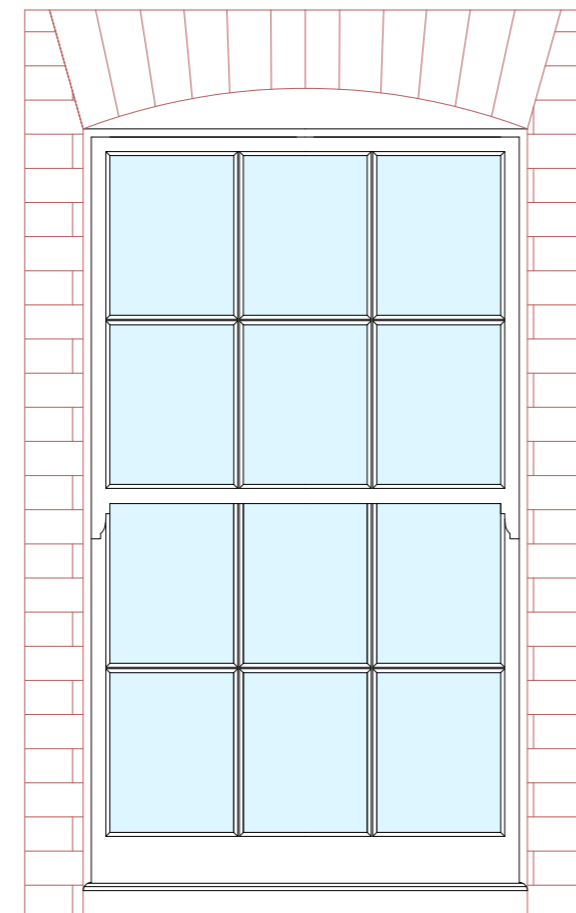
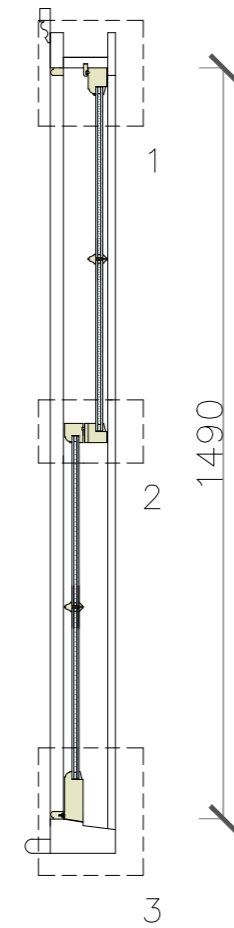

EXTERNAL ELEVATION

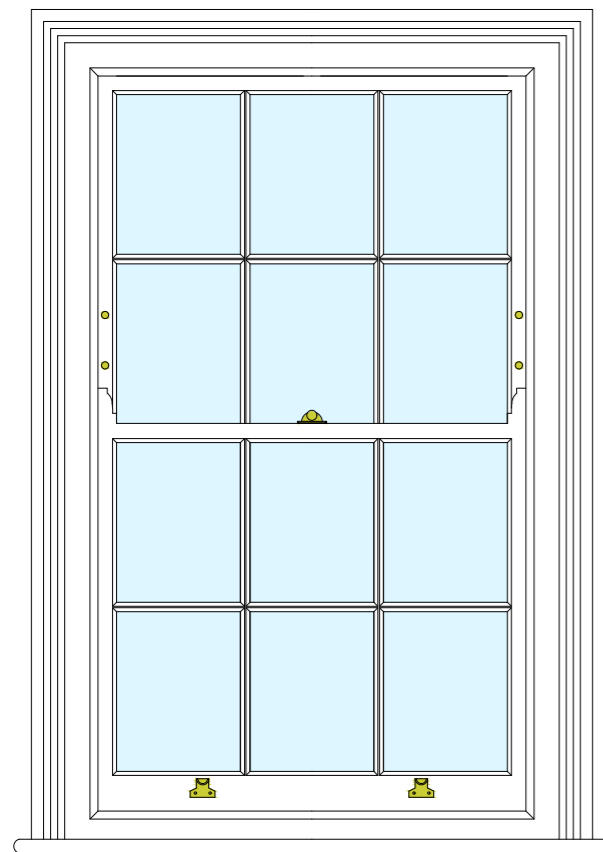

INTERNAL ELEVATION

PLAN VIEW

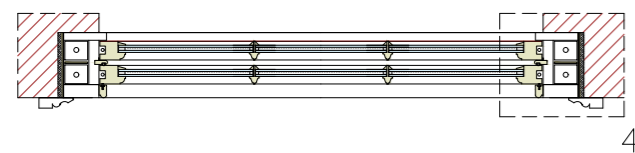

DETAIL 4  
SCALE 1:2

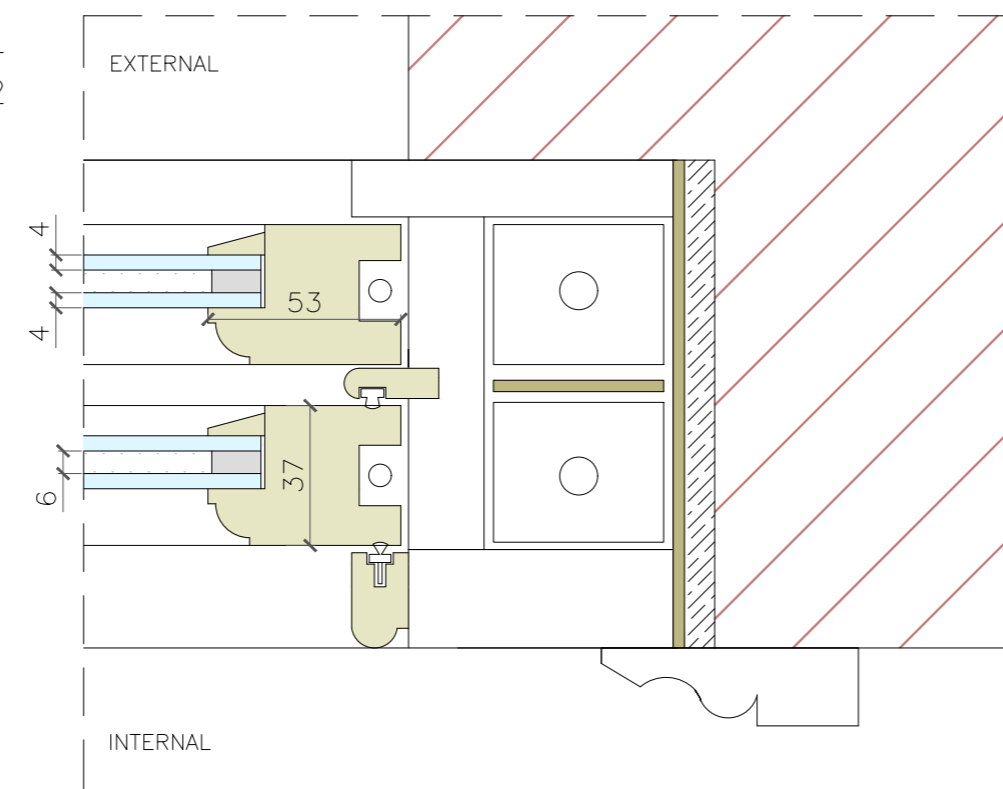

ITEMS DETAIL  
SCALE 1:2

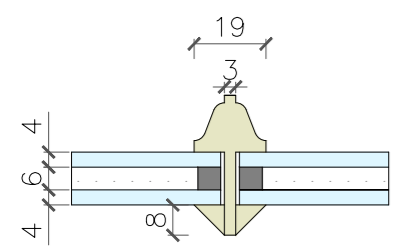

GLAZING BAR

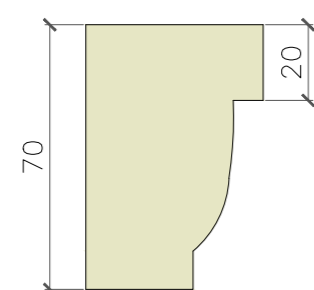

SASH HORN

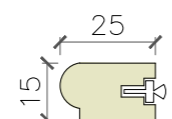

STAFF BEAD

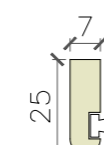

PARTING BEAD

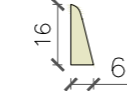

GLAZING BEAD