

PERIMETER SCREW FOR FYTOTEXTILE MODULES

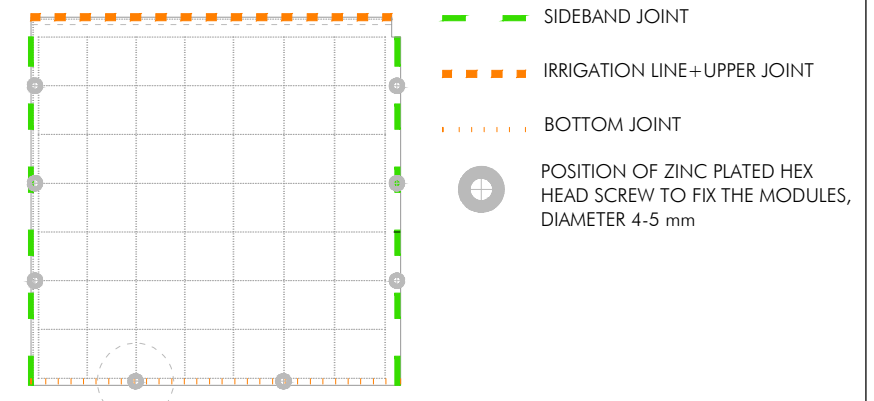

VERY IMPORTANT
SCREW ONLY ON THE BOTTOM OF THE
LIVING WALL, **NOT ON THE INTERMEDIATE**
POSITION

DETAILED VERTICAL SECTION

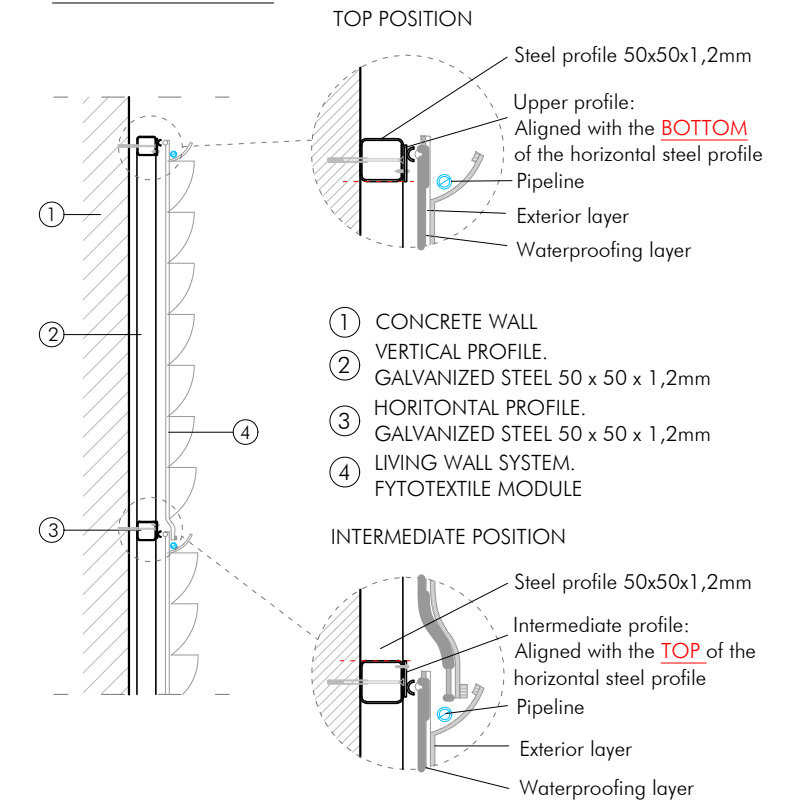

LIVING WALL SYSTEM



CONSULTOR 	PROJECT HALL SCHOOL - SCOTSCAPE
INSTALLER 	DRAWING TYPE AND OVERLAY OF MODULES
CODE INT 27004	DRAWING NUMBER 01.01 V1
	16-01-2024 S-A3 1:50