

DO NOT SCALE DRAWINGS. THE CONTRACTOR IS RESPONSIBLE FOR CHECKING DIMENSIONS & ANY DISCREPANCY IS TO BE REFERRED TO THE ARCHITECT.

ALL RAILINGS TO HAVE WELDED JOINTS. JOINTS TO BE GROUND DOWN & MADE NEAT PRIOR TO POWDERCOATED FINISH BEING APPLIED. SPECIALIST CONTRACTOR TO VERIFY SUITABILITY OF MEMBER SIZES PRIOR TO MANUFACTURE. WORKSHOP DRAWINGS TO BE SUBMITTED FOR APPROVAL PRIOR TO MANUFACTURE.

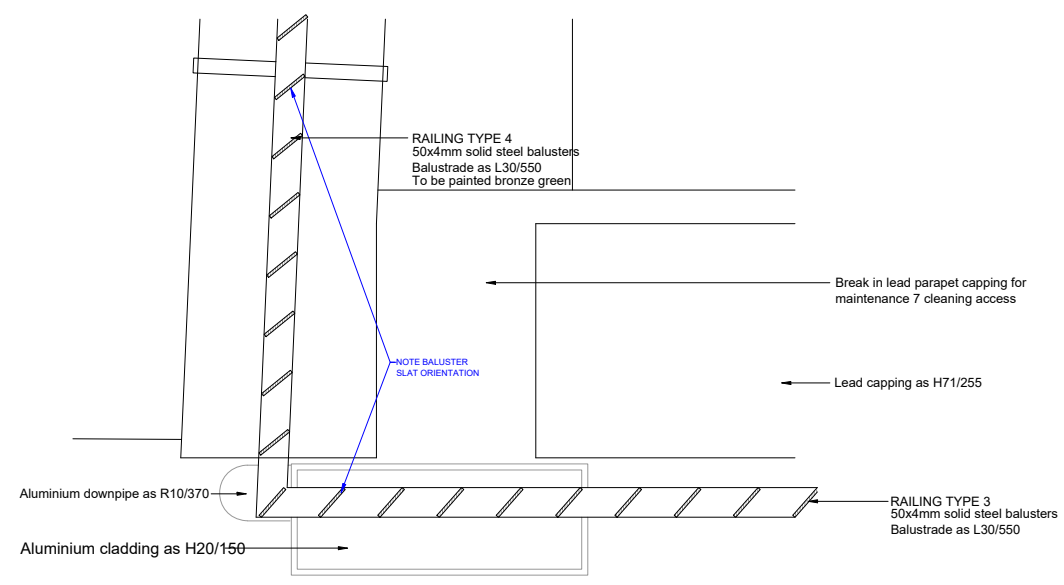

**A** RAILING TYPES 3 & 4  
CORNER PLAN DETAIL Scale 1:5  
DET-40

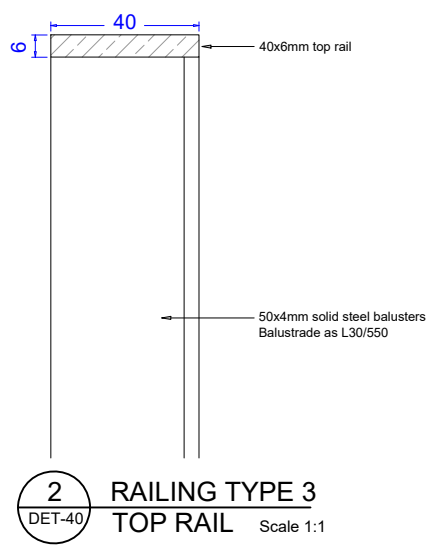

**2** RAILING TYPE 3  
TOP RAIL Scale 1:1  
DET-40

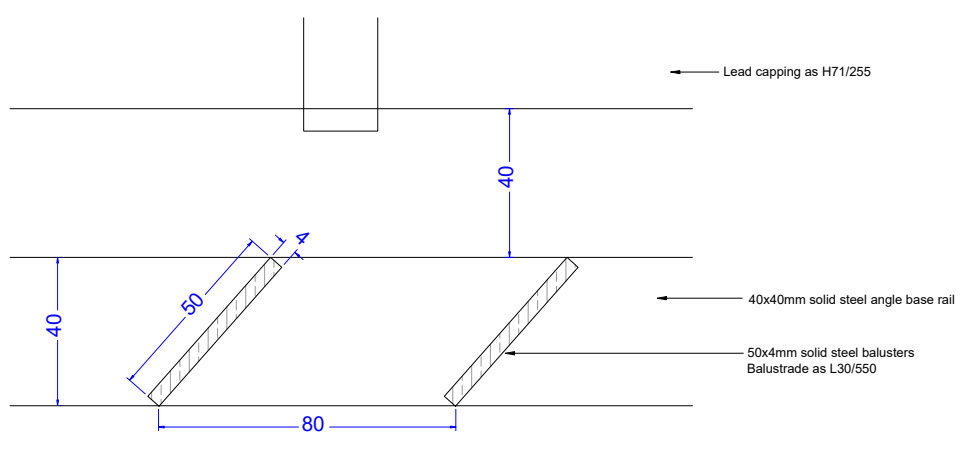

**1** RAILING TYPE 3  
BALUSTER PLAN Scale 1:1  
DET-40

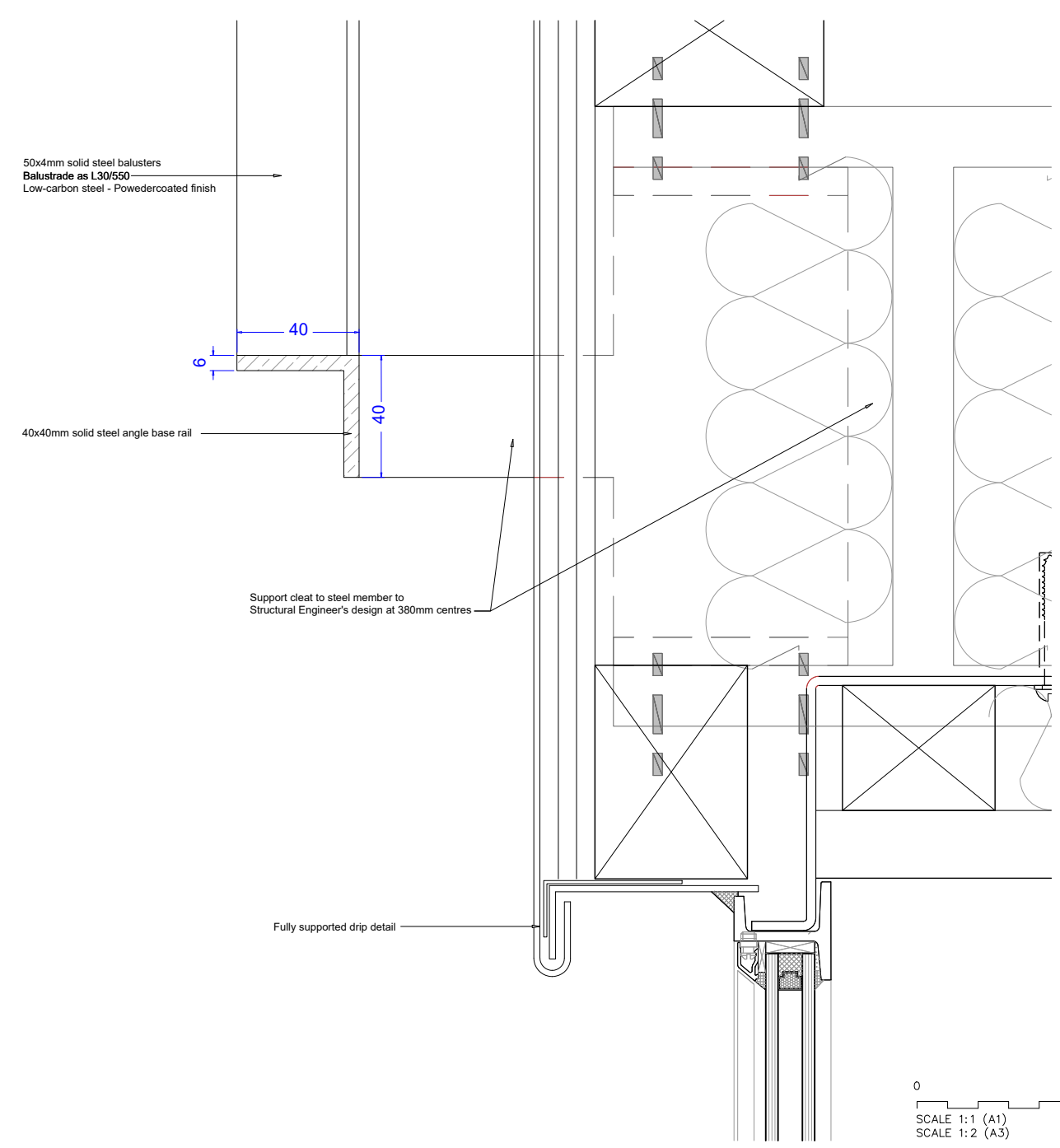

**3** RAILING TYPE 3  
BASE RAIL Scale 1:1  
DET-40

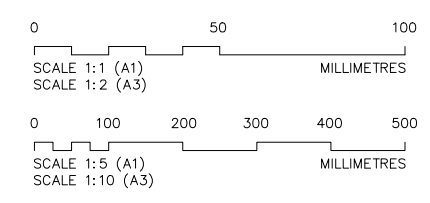

P1	PLANNING	December 23
REV.	AMENDMENT	DATE

**THOMAS FORD & PARTNERS**  
CHARTERED ARCHITECTS SURVEYORS

177 KIRKDALE  
SYDENHAM • LONDON • SE26 4QH  
TEL 020 8659 3250 • FAX 020 8659 3146  
EMAIL tfp@thomasford.co.uk

PROJECT  
41 DOUGHTY STREET  
RENOVATION  
CAMDEN

TITLE  
RAILING TYPE 3 - SHEET 2

DRAWN	DATE	SCALES	CHECKED
Sed	Jul 22	1:5/1@A1	
PROJECT REF.	DRG. No.	REV	
381401	DET-40	P1	