



SJ Stephens Associates

ARBORICULTURAL, LANDSCAPE &
MANAGEMENT CONSULTANTS

Savernake Barn
Stokke Common
Great Bedwyn
Marlborough
Wiltshire SN8 3LL
Tel: 01672 871 862
www.sjstephens.co.uk
e: info@sjstephens.co.uk

Arboricultural Impact Assessment

- Tree Survey
- Tree Protection Plan
- Arboricultural Method Statement

For:-

Air Source Heat Pump
Installation

At:-

58a Reddington Road
London
NW3 7RS

On behalf of:-

Gwen McDougal
58a Reddington Road
London
NW3 7RS

Prepared by:

Simon Stephens MA Oxon, Dip
Arb(RFS), MArborA, C Env. MICFor
Email: simon@sjstephens.co.uk

Survey Date: 18th April 2023
Report Date: 1st February 2024
Project no: 2084

CONTENTS

- 1 BACKGROUND
- 2 SURVEY DETAILS AND SCOPE
- 3 SURVEY LIMITATIONS
- 4 LEGAL PROTECTION OF TREES
- 5 ARBORICULTURAL METHOD STATEMENT
- 6 ARBORICULTURAL IMPACT ASSESSMENT
- 7 REFERENCES

Appendices

- A Tree Protection Plan: drawing no: 2084-02revA
- B Tree Schedule
- C BS 5837:2012 - Trees in relation to design, demolition and construction, Table 1
- D Tree Protection Fencing Detail
- E Proposed Site Plan

1 BACKGROUND

- 1.1 This Arboricultural Impact Assessment has been instructed by TAG Architects, on behalf of the owner to specify tree protection measures and assess the arboricultural impact of installing air source heat pumps in the garden along with the necessary pipework.
- 1.2 Trees were surveyed, with findings shown in the Tree Schedule in Appendix B and plotted on the Tree Protection Plan in Appendix A. This also shows tree protection measures, which are specified in the Arboricultural Method Statement in section 5 below. The arboricultural impact is assessed in section 6, which assumes that these measures are followed.
- 1.3 The tree survey was undertaken, and this report has been prepared, by Simon Stephens MA Oxon, Dip Arb (RFS), MArborA, C Env, MICFor a Registered Consultant with the Arboricultural Association, with over 20 years relevant experience.
- 1.4 This survey and report have been prepared in accordance with the recommendations of BS 5837:2012, Trees in relation to design, demolition and construction - Recommendations.
- 1.5 Documentation supplied:
 - Topographical Survey
 - TAG Architects, Proposed Site Plan: drawing no PO1C

2 SURVEY DETAILS AND SCOPE

- 2.1 The site survey included trees and shrubs, which could be affected by the proposals, with a stem diameter over 75mm at 1.5m height, as shown located on the Tree Protection Plan, included as Appendix A.
- 2.2 Tree inspection took place from ground level with the use of binoculars, sounding hammer and metal probe using the Visual Tree Assessment method (Mattheck & Breloer 1994). The presence and condition of bark and stem wounds, cavities, decay, fungal fruiting bodies and any structural defects that could increase the risk of structural failure were noted.
- 2.3 Tree diameters were measured using a girthing tape and tree heights were measured using a hypsometer. Where use of a tape was restricted by site factors, diameters were estimated, with the diameter recorded in the tree schedule as eg “est 300”.
- 2.4 At the time of the survey, the weather was fine, but with no restrictions to visibility. Broadleaf trees were not in leaf. There were no limitations to access around the trees within the site.
- 2.5 Tree details are shown on the Tree Protection Plan included as Appendix A. Tree locations have been taken from the topographical survey provided. Where not included on the topographical survey, they have been determined by measuring distances from features shown on the plan, using a laser measuring device. The following information was recorded for each tree, and is shown in the Tree Schedule included as Appendix B:
- **Number:** an identity number for each tree, prefixed with a “T”, which cross references locations shown on the plan with the schedule in Appendix B. Where a number of trees are located close together and are similar in character and management requirements, they have been treated as a Group under a single number, prefixed with a “G”.
 - **Species:** common name.
 - **Tree height:** approximate height in metres.
 - **Stem diameter:** diameter in millimetres, taken at 1.5m above ground. Where there are a number of stems, stem diameters are recorded in the condition column.
 - **Branch spread:** approximate spread in metres to N,S,E and W of the trunk. The approximate branch spread is drawn on the plan.
 - **Canopy clearance:** approximate height of the canopy above ground. Where a significant, low lateral branch is present, its height and direction of growth is included in the Condition column.
 - **Age class:** Young, Semi-mature, Early mature, Mature, Over-mature, Veteran.
 - **Condition:** features that affect the safe useful life expectancy and amenity of the tree, including the presence of decay or any physical defect.
 - **Management Recommendations:** recommendations to ensure the health and safety of the tree, within the future development.
 - **Estimated Remaining Contribution:** <10 years, 5-15 years, 10-20 years, 15-30 years, 20-40 years, >40 years.

- **Category grading:** tree classification taken from BS 5837:2012, Trees in relation to design, demolition and construction (see Appendix C for details), as follows:
 - Category U: Unsuitable for retention, trees with less than 10 years life expectancy, normally recommended for removal (Red)
 - Category A: high quality trees, able to make a substantial contribution for at least 40 years, normally retained unless there is an over-riding reason for removal and appropriate mitigation. (Green)
 - Category B: moderate quality trees, able to make a significant contribution for at least 20 years, normally retained. (Blue)
 - Category B/C: an intermediate category between categories B and C (not specifically described in BS5837). Trees, which should be retained wherever possible, providing retention does not unreasonably constrain the layout. (Blue)
 - Category C: low quality, in adequate condition to remain for at least 10 years, or young trees <150mm stem diameter. Trees which can be removed to allow the desired layout or new planting. (Grey)

For category A, B and C trees, a subcategory has been allocated, providing information on the reasons for selection of a specific category, as follows:

- Subcategory 1: mainly arboricultural values.
 - Subcategory 2: mainly landscape values.
 - Subcategory 3: mainly cultural values, including conservation.
- Trees have been classified irrespective of the possible proximity to future construction. The BS 5837 category is colour coded, as indicated above, on the plan included as Appendix A.
 - **Protection Distance:** the protection distance in metres required to provide the Root Protection Area recommended in BS 5837, assuming a circular area centred on the tree.
 - **Root Protection Area (RPA):** the area in m², as recommended in BS 5837, to provide sufficient rooting area to ensure tree survival and which, in most situations, should be fenced off to prevent root damage from construction activities.

3 SURVEY LIMITATIONS

- 3.1 No internal decay devices, or other invasive tools to assess tree condition, were used.
- 3.2 No soil excavation or root inspection was carried out.
- 3.3 This survey has not considered the effect that trees or vegetation may have on the structural integrity of future building through subsidence or heave.

- 3.4 The tree survey has been undertaken for planning purposes. Although any obvious structural defects have been noted, a Tree Hazard Assessment has not been carried out. Mature trees close to highly populated areas or public highways should normally be checked for safety annually, by a suitably qualified person.

4 LEGAL PROTECTION OF TREES

- 4.1 Since the site is covered by a Conservation Area, six weeks notification must be given to the Local Planning Authority of any intended tree surgery works, to allow them the option of placing a Tree Preservation Order.
- 4.2 Once planning permission has been granted, provided the application clearly shows any trees to be removed or pruned, this overrides protection provided by Tree Preservation Orders or Conservation Areas, provided the work is necessary to implement the approved development. If not essential, a separate tree work application will need to be submitted for trees protected by a Tree Preservation Order.

5 ARBORICULTURAL METHOD STATEMENT

5.1 Site Overview

- 5.1.1 The proposal is for the installation of air source heat pumps in the garden along with the necessary concrete bases and pipework. The proposed site plan is included as Appendix E and has been added to the survey drawing, along with tree details, to create the Tree Protection Plan attached as Appendix A.
- 5.1.2 There is a fine veteran oak, T2, and a mature beech, T8, which are of high landscape and environmental value together with a range of other trees including a yew, a tulip tree and a Scots pine.

5.2 Tree Work

- 5.2.1 No tree work is proposed.

5.3 Root Protection Areas

- 5.3.1 Root Protection Areas are shown for all trees in the tree schedule included as Appendix B. They are also shown for all retained trees, as circular areas centred on the trunk, on the Tree Protection Plan included as Appendix A. Where there are physical obstructions to root growth the Root Protection Area should be shown as an equivalent area that is more likely to reflect actual root growth. The Root Protection Area shows the area around a tree in which all

construction activity must normally be excluded, unless appropriate protection measures are implemented.

5.4 Tree Protection Fencing

5.4.1 Tree Protection Fencing must be erected where shown on the Tree Protection Plan, included as Appendix A. This will provide full protection of the Root Protection Areas of all retained trees within the site, other than for:

- areas hatched in blue on the Tree Protection Plan, where No-Dig Construction must be used, as described in section 5.5 below, to protect underlying roots.
- areas shaded cyan on the Tree Protection Plan, indicating Ground Protection Areas, where roots must be protected, as described in section 5.6 below.
- areas cross hatched red on the Tree Protection Plan, where there will be excavation at the edge of Root Protection Areas, but where hand excavation must be used, as described in section 5.7, to minimise potential root damage.

5.4.2 Tree Protection Fencing must be from weldmesh panels, at least 2m high, securely fixed, with wire or scaffold clamps, to a rigid framework. This framework must be constructed from scaffold tubes with vertical tubes, at a maximum interval of 3m and driven into the ground at least 0.6m. The structure must be well braced to resist impacts, constructed as per Figure 2 of BS5837:2012, which is reproduced in Appendix D. Alternatively, weldmesh panels can be supported on blocks, providing the blocks are pinned to the ground with road pins, or similar, and the panels are braced, as per Figure 3 of BS5837:2012, which is also reproduced in Appendix D.

5.4.3 Tree Protection Fencing must be maintained and retained for the duration of the works, or until such time as agreed in writing with the Local Planning Authority.

5.4.4 Weatherproof notices must be fixed to the Tree Protection Fencing, and maintained, stating:-

TREE PROTECTION AREA
KEEP OUT
TREES ENCLOSED BY THIS FENCE ARE PROTECTED BY PLANNING CONDITIONS
AND CONSERVATION AREA STATUS
CONTRAVENTION MAY LEAD TO CRIMINAL PROSECUTION
THE FOLLOWING MUST BE OBSERVED BY ALL PERSONS:

- The Protection Fence must not be moved
- No person or machine must enter the area
- No materials or spoil must be deposited
 - No excavation must be permitted

ANY INCURSION INTO THE PROTECTED AREA MUST BE WITH THE WRITTEN
PERMISSION OF THE LOCAL PLANNING AUTHORITY

5.5 No-Dig Construction Areas

- 5.5.1 The No-Dig areas, shown hatched blue on the Tree Protection Plan included as Appendix A, must be constructed without excavation apart from the removal of turf/organic matter, which must be carried out by hand. Excavators, dumpers and other site traffic must not be allowed to track on the No-Dig areas until roots are protected by the No-Dig surfacing or ground protection.
- 5.5.2 The proposed concrete slabs for the air source heat pumps must be built on top of existing levels without excavation. Engineering details must include a cellular confinement system filled with clean stone, which will prevent soil compaction and allow gaseous diffusion to and from underlying roots. A typical section is shown on the Tree Protection Plan. As well as being fit for purpose, the design and methodology must protect tree roots, by following the following construction methodology:-
- topsoil/turf can be removed carefully by hand to a maximum of 75mm, but less if roots are found nearer the surface.
 - following leveling with soil or sand, a permeable, non-woven geotextile membrane, must be laid.
 - pressure treated timber edging boards, supported by driven stakes must be used.
 - a suitable cellular confinement system must then be laid to manufacturers instructions. Products that might be considered include Geoweb, supplied by Greenfix (www.greenfix.co.uk) or Cellweb, supplied by Geosynthetics Ltd (www.geosyn.co.uk).
 - the cellular confinement system must be filled with clean (no fines), washed angular, 20/40mm, stone to provide load support, while allowing air and moisture to permeate to the root zone. The depth of the cellular confinement system must be confirmed with the suppliers as being adequate to protect the ground during pile driving operations.
 - a further non-permeable, geotextile membrane, or heavy-duty polythene must then be laid before the reinforced concrete base is laid.
 - removed turf/topsoil can be used to grade surrounding ground levels.
- 5.5.3 Site traffic, including pedestrians, must not be allowed on the No-Dig areas unless roots are protected by existing hard surfacing, new No-Dig surfacing or unless suitable ground protection panels are laid. Either Trakmats (supplied by the Marwood Group, www.marwoodgroup.co.uk), Groundtrax panels (see www.groundtrax.com), Ground-Guards, as supplied by Greentek (www.greentek.org.uk), or a similar approved product, must be used, laid on top of a compressible layer of sand or woodchips, laid onto a geotextile. If access is only required for pedestrians, 25mm plywood or side butting scaffold boards can be laid, on top of a compressible layer of sand or woodchips, laid onto a geotextile.

5.6 Ground Protection Areas

- 5.6.1 The Ground Protection Areas shown shaded cyan on the Tree Protection Plan, can be used for general site use, provided ground protection is installed to protect tree roots. Trakmats, as supplied by either the Marwood Group, (www.marwoodgroup.co.uk) or Ground-Guards, (www.ground-guards.co.uk) or a similar approved product, must be used, laid on a

compressible layer of sand or woodchips, laid onto a geotextile, with adjacent panels held together with connectors.

- 5.6.2 Ground protection must be laid before any construction starts on site and must be maintained in good condition until all construction operations have been completed. Ground protection must be fit for purpose and be replaced with an alternative product if panels start to move or any sign of ground compaction is seen.

5.7 Hand Dig Area

- 5.7.1 Services to the ASHP units will be installed in a hand dug trench, where indicated cross-hatched red on the Tree Protection Plan. The trench must be hand dug, retaining all roots greater than 25mm diameter and as many smaller roots as possible. Either hand tools or an air spade can be used. On completion the trench must be inspected by the arboricultural consultant.
- 5.7.2 The services must then be threaded between any roots, before backfilling the trench with the excavated soil. If the location of roots makes this impossible, the retained arboricultural consultant must inspect and advise. The trench must be left open for as short a time as possible, with any exposed roots covered with hessian to prevent desiccation or frosting.

5.8 General measures

- 5.8.1 No construction activity whatsoever, including routing of underground services, storage of materials or on-site parking, must be allowed within Root Protection Areas, other than that specifically described above.
- 5.8.2 No mixing or storage of cement, concrete, oil, fuel, bitumen or other chemicals must be permitted within 10m of the trunk of any retained trees, nor in any position where the slope of the ground could lead to contamination of the Root Protection Area.
- 5.8.3 Fires must not be lit in a position where their flames could extend to within 10m of foliage, branches or trunk.
- 5.8.4 Landscape works carried out within Root Protection Areas must be undertaken with great care so as not to damage shallow roots. Tractor mounted rotovators or other heavy mechanical cultivation must not be used within the Root Protection Areas.
- 5.8.5 If any tree shown for retention is removed, uprooted or destroyed, another tree must be planted in the same location, at a size and species to be agreed in writing with the Local Planning Authority.

5.8.6 A copy of this report and the Tree Protection Plan must be kept on site and must be fully understood by the Site Agent.

5.9 Arboricultural Supervision

5.9.1 A qualified Arboricultural Consultant must be retained during the period of construction to carry out the following:

- to liaise with the contractor, prior to construction or ground work starting on site, to ensure this Arboricultural Method Statement is fully understood and can be complied with in full. If any revisions are required, a revised Arboricultural Method Statement must be approved by the Local Planning Authority, prior to construction or demolition starting on site.
- to inspect the hand dig trench before services are threaded below/between roots and the trench is back filled.
- to carry out monthly site visits during the period that works related to installation of the heat pumps are ongoing.
- as necessary, to advise on any issues at the request of the local planning authority, the developer, architect or contractor.

The details of all site visits must be recorded using a site visit proforma, with copies circulated to the contractor, developer and the local authority Tree Officer within 3 working days of the visit.

6 ARBORICULTURAL IMPACT ASSESSMENT

6.1 No tree work is proposed.

6.2 Protection measures have been specified to protect the Root Protection Areas of all retained trees.

6.3 Provided the recommendations in this report are followed, the arboricultural impact of these proposals on existing trees is considered acceptable.

7 REFERENCES

- *BS5837:2012 Trees in relation to design, demolition and construction – Recommendations.*
- *BS3998:2010 Tree Work. Recommendations.*
- *NJUG 10: Guidelines for the planning, installation and maintenance of Utility Services in proximity to trees. (Published by the National Joint Utilities Group) Issue 2:16th November 2007.*
- *Common sense risk management of trees (FCMS024). Published by the National Tree Safety Group (www.ntsgroup.org.uk)*
- *The use of Cellular Confinement systems near Trees: a guide to good practice Arboricultural Association Guidance Note 12.*

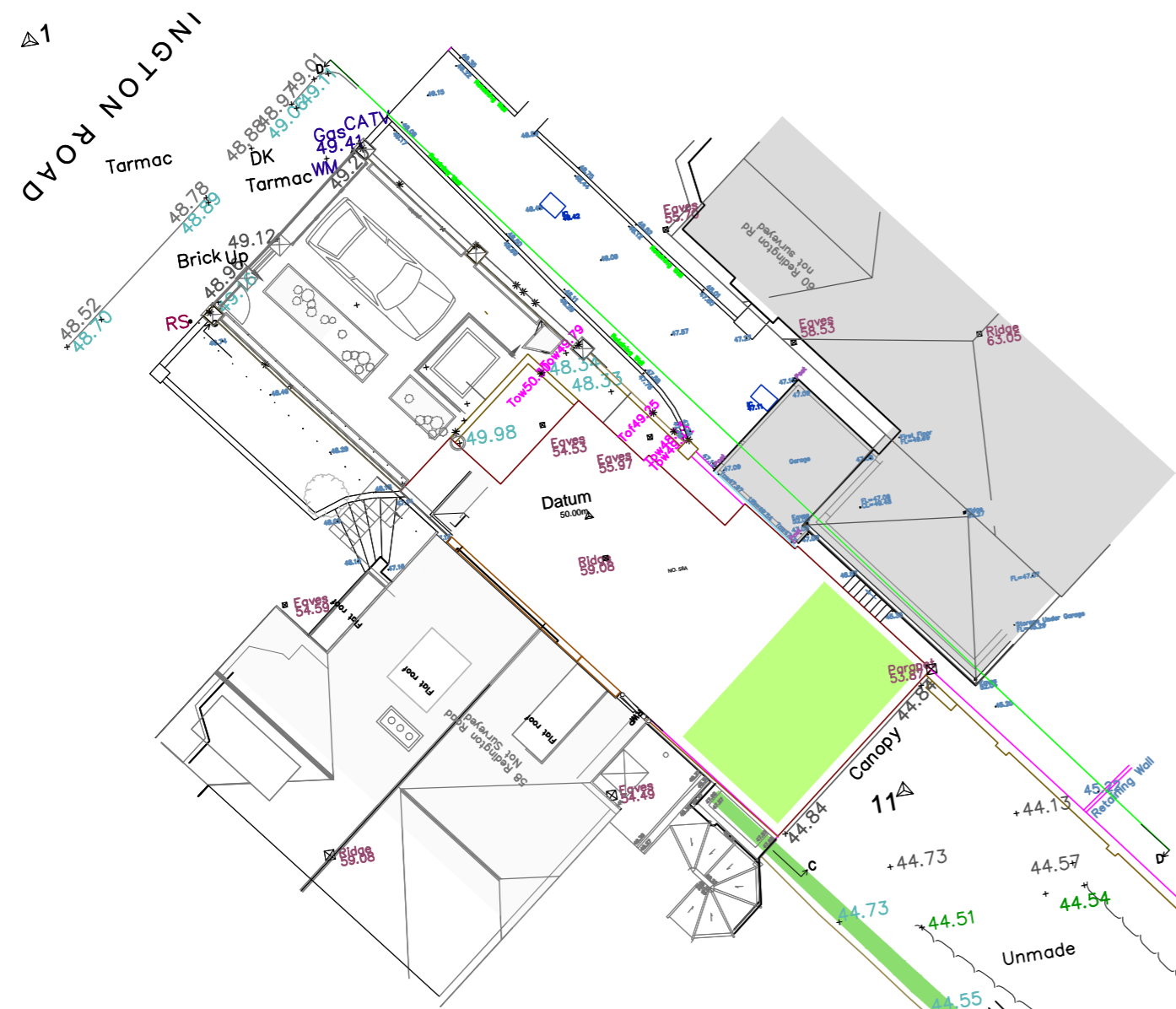

BS 5837: TREE CATEGORY GUIDE

- Category U:** Unsuitable for retention, trees with less than 10 years life expectancy.
- Category A:** high quality trees, able to make a substantial contribution for at least 40 years, normally retained unless there is an over-riding reason for removal and appropriate mitigation.
- Category B:** moderate quality trees, able to make a significant contribution for at least 20 years, normally retained.
- Category B/C:** an intermediate category between categories B and C (not specifically described in BS5837). Trees, which should be retained wherever possible, providing retention does not significantly constrain the layout.
- Category C:** low quality, in adequate condition to remain for at least 10 years, or young trees <150mm stem diameter. Trees which can be removed to allow the desired layout or new planting.

APPENDIX A

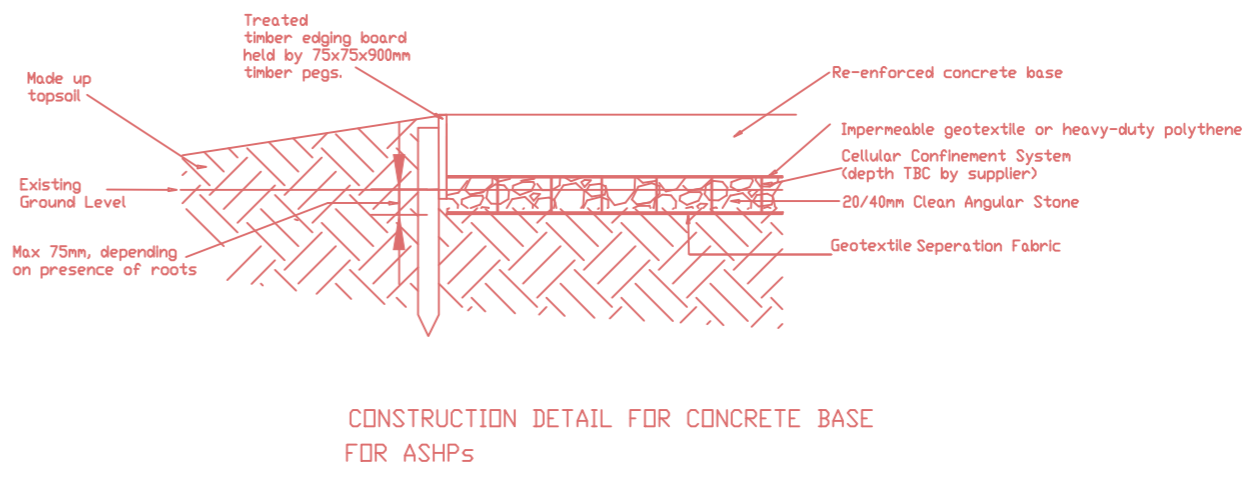
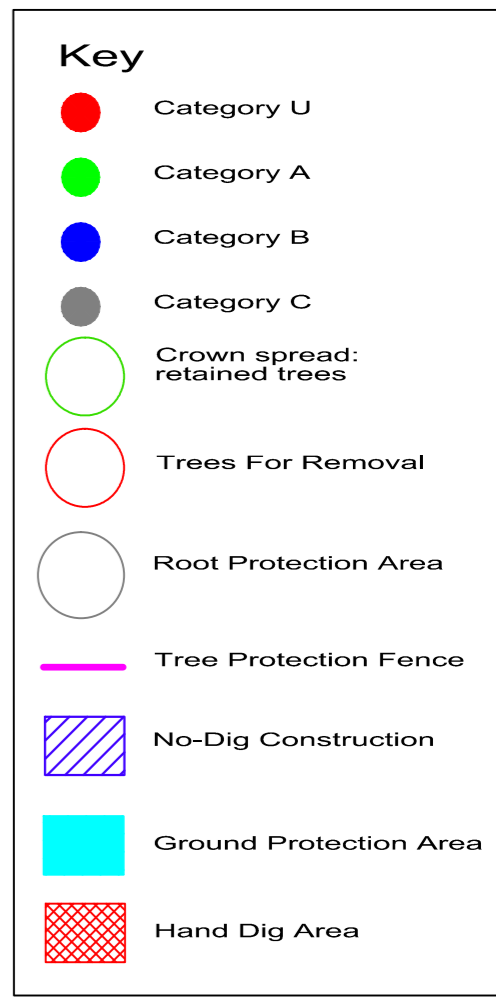

Services trench 300 x 1000mm deep for supply cables for ASHPs, formed along the side of the garden path and covered flush with soil.

Acoustic enclosures housing ASHPs.

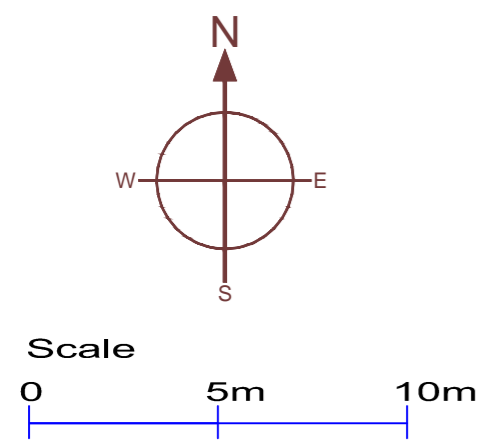
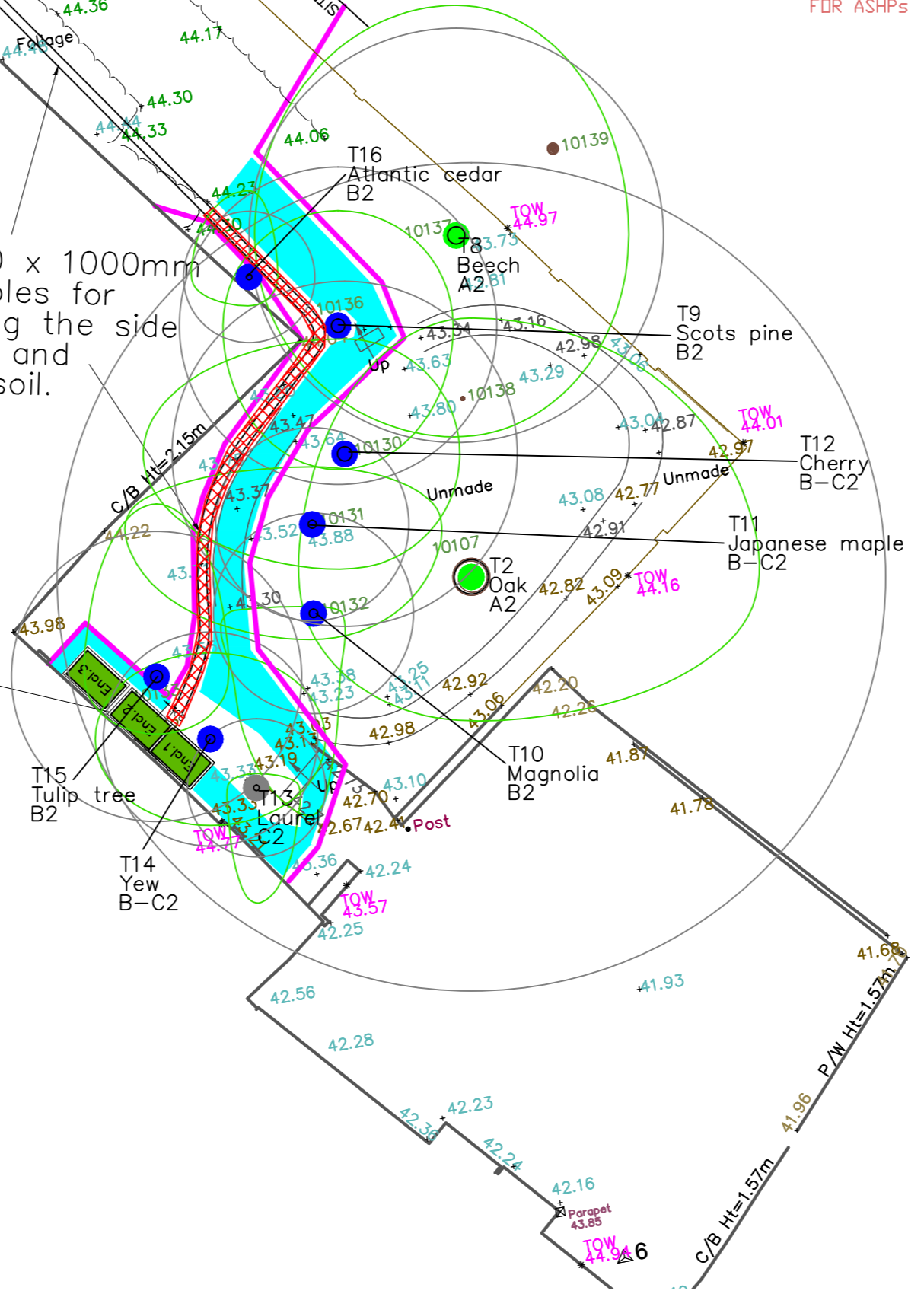

SJ Stephens Associates
 Savernake Barn, Stokke Common
 Great Bedwyn
 Marlborough
 Wiltshire SN8 3LL
 01672 871862
 www.sjstephens.co.uk

JOB TITLE 58a REDINGTON ROAD	
DRAWING TITLE TREE PROTECTION PLAN - ASHP HEAT PUMPS	
DRAWING NUMBER 2084-02	REV A
REVISIONS	
SCALE 1:200 at A2	DATE FEB 24
DRAWN BY sjss	

Tree/ Group No.	Species	Height (m)	Stem Diam. at 1.5m (mm)	Branch Spread (m)				Canopy Cleara- nce (m)	Age Class	Observations	Management Recommendations	Estimated Remaining Contribution (years)	BS 5837 Category Grading	Protect- ion Distnce (m)	Root Protect. Area (m2)
				N	S	E	W								
T2	Oak	15	est 1200	9	5	10	6	2.5	Veteran	Fine veteran tree. Occasional dead branches providing good deadwood habitat. Canopy reduced in past.	Must maintain low epicormic growth, which could provide future canopy.	>40	A2	15.0	707
T8	Beech	19	600	8	7	6	7	1.8	Mature	High amenity value		>40	A2	5.8	104
T9	Scots pine	17	460	4	5	4	4	8	Mature	High amenity value		20-40	B2	4.6	65
T10	Magnolia	10.5	290	0	7	1	3	2.4	Mature	Acute lean to south. Dead branch to north. Reasonable overall vigour.		20-40	B2	3.5	38
T11	Japanese maple	5	280	2	4	4.5	6.5	0.6	Early mature	Twin stems from 0.6m -190 and 210mm.		15-30	B-C2	3.4	35
T12	Cherry	11	500	4	4	4	7	3.5	Mature	3 stems from 0.8m - average 290mm. Occasional dead branchers. Moderate vigour. Ornamental variety.		10-20	B-C2	6.0	113
T13	Laurel	6	200	0.5	4	1.5	1	0.8	Early mature	Leaning to south.		15-30	C2	2.4	18
T14	Yew	4	310	3	3	4	4	0.3	Semi Mature	Bushy form - awkward structure with 5 stems average 140mm.		>40	B-C2	3.7	43
T15	Tulip tree	16	420	6	2	2.5	2.5	8	Early mature	Leaning to north. Low branches dead.		20-40	B2	5.0	80
T16	Atlantic cedar	8.5	190	3	1	1	2	1.6	Semi Mature	Asymmetric canopy		>40	B2	2.3	16

1st February 2024

BS 5837:2012, Table 1 Cascade chart for tree quality assessment

Category and definition	Criteria (including subcategories where appropriate)			Identification on plan
Trees unsuitable for retention (see Note)				
Category U Those in such a condition that they cannot realistically be retained as living trees in the context of the current land use for longer than 10 years	<ul style="list-style-type: none"> Trees that have a serious, irremediable, structural defect, such that their early loss is expected due to collapse, including those that will become unviable after removal of other category U trees (e.g. where, for whatever reason, the loss of companion shelter cannot be mitigated by pruning) Trees that are dead or are showing signs of significant, immediate, and irreversible overall decline Trees infected with pathogens of significance to the health and/or safety of other trees nearby, or very low quality trees suppressing adjacent trees of better quality <p><i>NOTE</i> Category U trees can have existing or potential conservation value which it might be desirable to preserve; see 4.5.7.</p>			See Table 2
	1 Mainly arboricultural qualities	2 Mainly landscape qualities	3 Mainly cultural values, including conservation	
Trees to be considered for retention				
Category A Trees of high quality with an estimated remaining life expectancy of at least 40 years	Trees that are particularly good examples of their species, especially if rare or unusual; or those that are essential components of groups or formal or semi-formal arboricultural features (e.g. the dominant and/or principal trees within an avenue)	Trees, groups or woodlands of particular visual importance as arboricultural and/or landscape features	Trees, groups or woodlands of significant conservation, historical, commemorative or other value (e.g. veteran trees or wood-pasture)	See Table 2
Category B Trees of moderate quality with an estimated remaining life expectancy of at least 20 years	Trees that might be included in category A, but are downgraded because of impaired condition (e.g. presence of significant though remediable defects, including unsympathetic past management and storm damage), such that they are unlikely to be suitable for retention for beyond 40 years; or trees lacking the special quality necessary to merit the category A designation	Trees present in numbers, usually growing as groups or woodlands, such that they attract a higher collective rating than they might as individuals; or trees occurring as collectives but situated so as to make little visual contribution to the wider locality	Trees with material conservation or other cultural value	See Table 2
Category C Trees of low quality with an estimated remaining life expectancy of at least 10 years, or young trees with a stem diameter below 150 mm	Unremarkable trees of very limited merit or such impaired condition that they do not qualify in higher categories	Trees present in groups or woodlands, but without this conferring on them significantly greater collective landscape value; and/or trees offering low or only temporary/transient landscape benefits	Trees with no material conservation or other cultural value	See Table 2

Figure 2

Key

- 1 Standard scaffold poles
- 2 Heavy gauge 2 m galvanised tube and welded mesh infill panels
- 3 Panels secured to uprights and cross-members with wire ties
- 4 Ground level
- 5 Uprights driven into the ground until secure (minimum depth 0.6 m)
- 6 Standard scaffold clamps

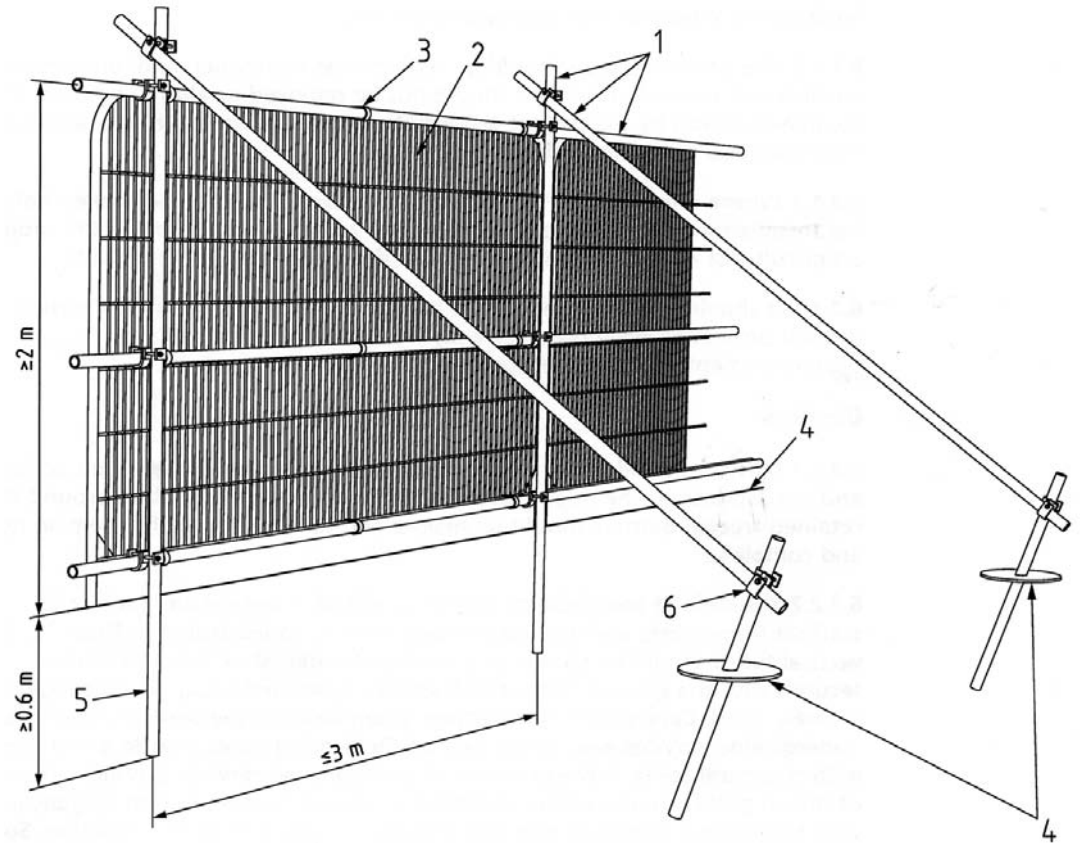

Examples of above-ground stabilising systems

Figure 3a

Stabiliser strut with base plate secured with ground pins

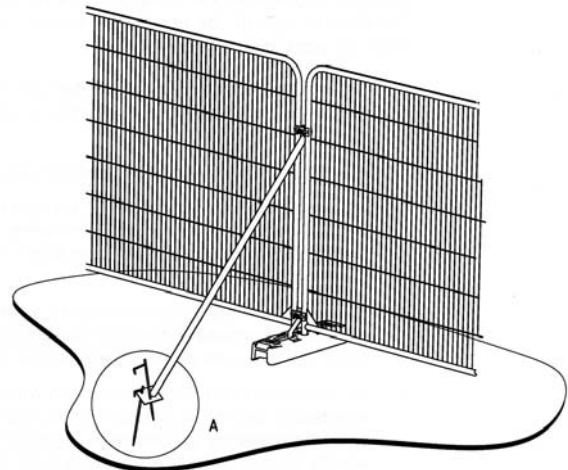
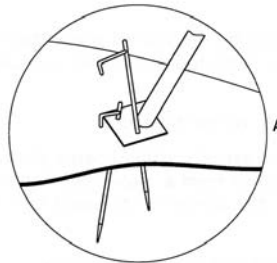
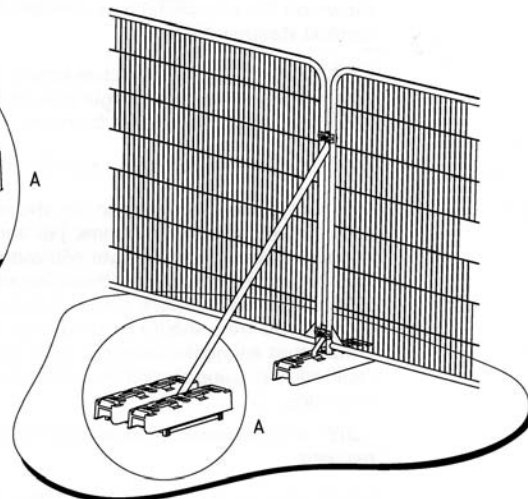
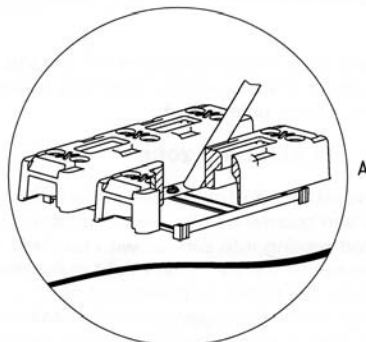
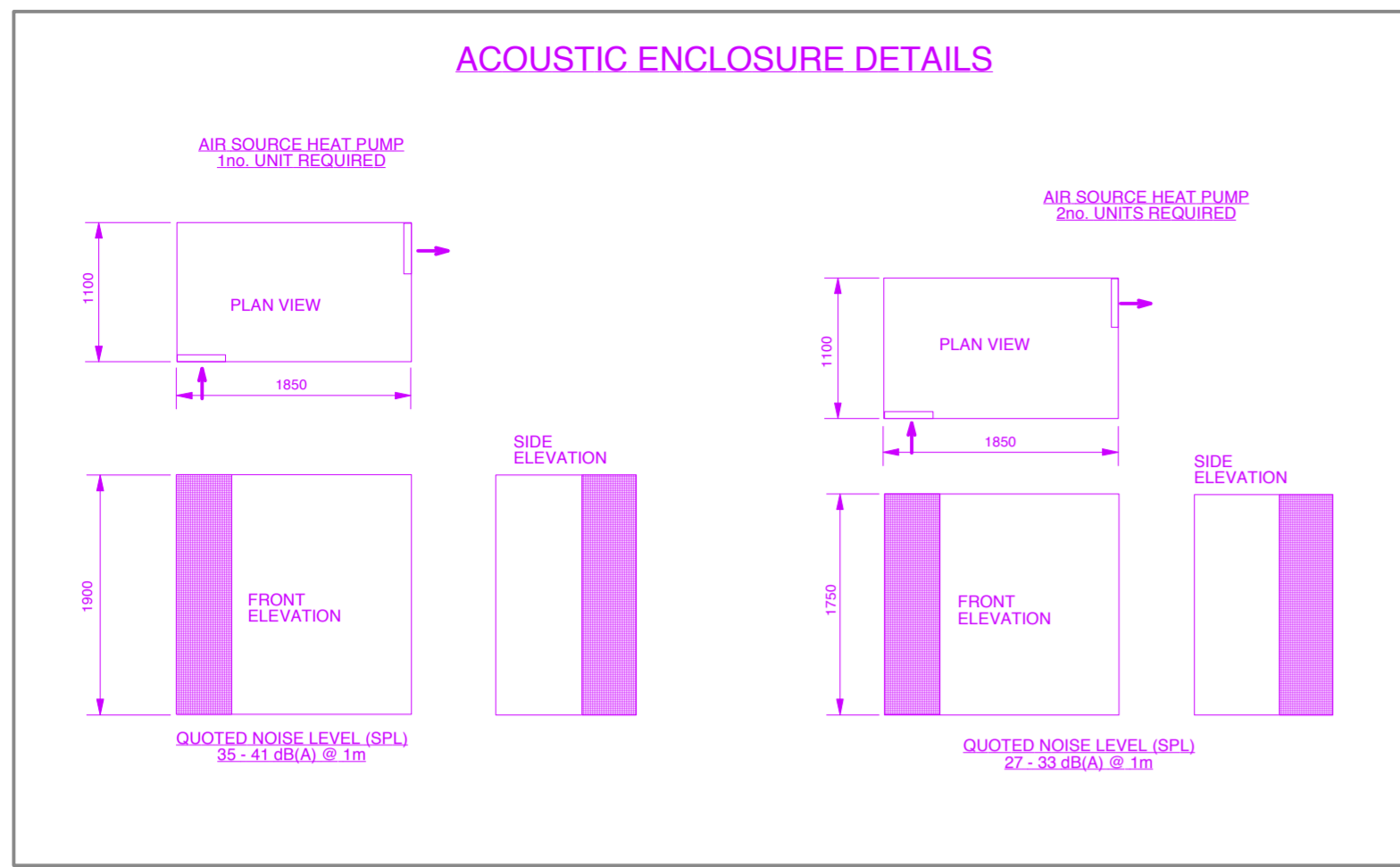

Figure 3b

Stabiliser strut mounted on block tray





NOTES RELATING TO THE GROUND WORKS:

1. This Proposal Drawing to be read in conjunction with the Arboricultural Impact Assessment (AIA) dated 24th April 2023 by SJ Stevens Associates.
2. All ground works to be carried out strictly in accordance with the Method Statement contained within the above AIA.
3. All trees and roots protection measures to be carried out in accordance with the above Method Statement.
4. Where minor excavation is required (eg. trench for cables, etc.), all to be done by hand, as noted in the above Method Statement.
5. Protective fences for the mature trees areas to be installed as shown on the Garden Plan included in the above AIA.
6. No site traffic or storage of any construction materials/tools on No-dig Areas shown on the above Garden Plan in the AIA.
7. Observe all General Measures relating to the works, as outlined in the above Method Statement.
8. Notify the Architect and/or the Arboricultural Consultant when required by the works progress, as outlined in the above Method Statement.

GENERAL NOTES:

1. In addition to the above, this Proposal Drawing to be read in conjunction with the following documents:
 - a. Design, Heritage and Planning Statement by ARAGON LAND & PLANNING.
 - b. Environmental Noise Report by NOICO dated 10th July 2020;
 - c. Acoustic Enclosure Sample 2055/5335;
 - d. Site Survey Drawing S01A by TAG ARCHITECTS;
 - e. Location Plan Drawing by TAG ARCHITECTS.

