

WIN(A)

QUANTITY: 21

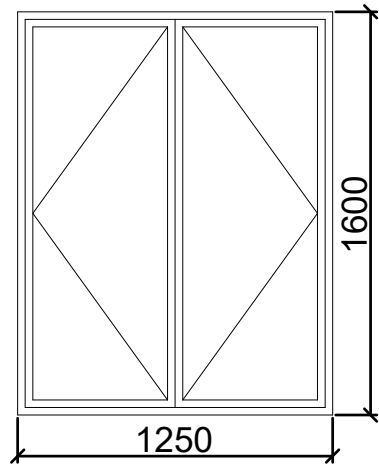

DR(B)

QUANTITY: 14

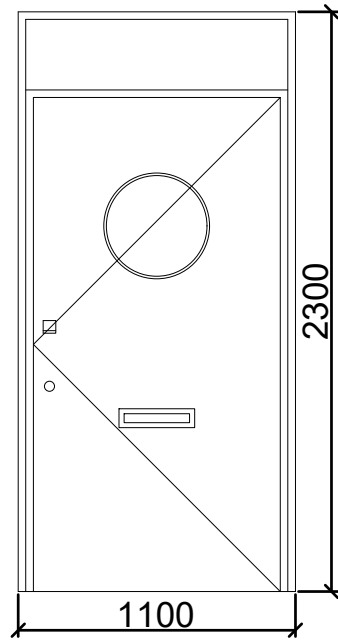

DR(C)

QUANTITY: 2

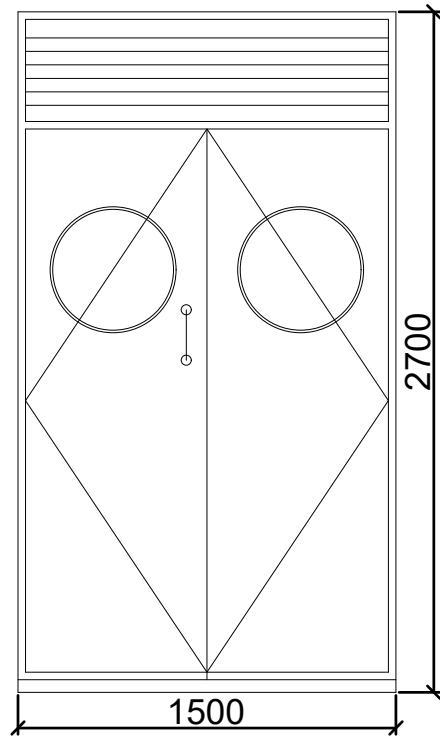

DR(D)

QUANTITY: 1

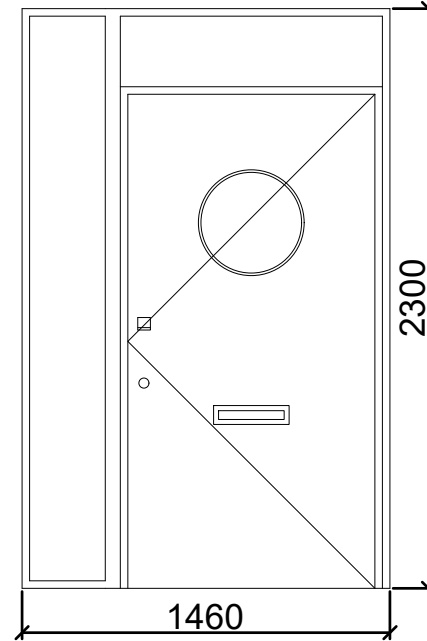

WIN(E)

QUANTITY: 3

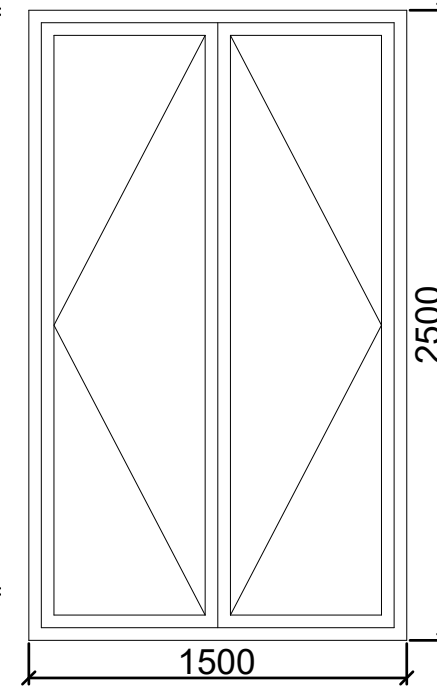

WIN(F)

QUANTITY: 15

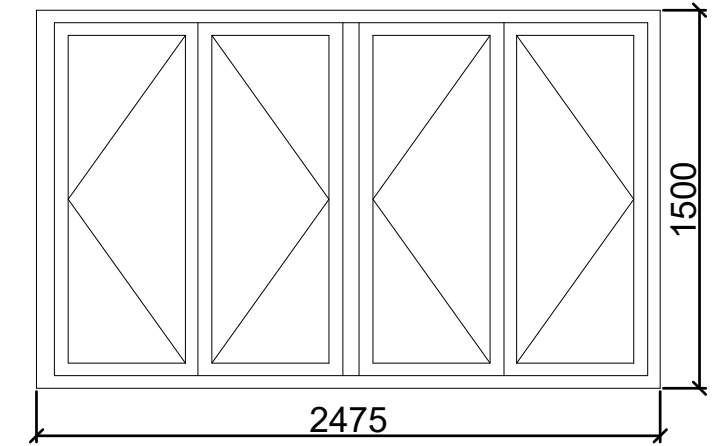

DR(G)

QUANTITY: 2

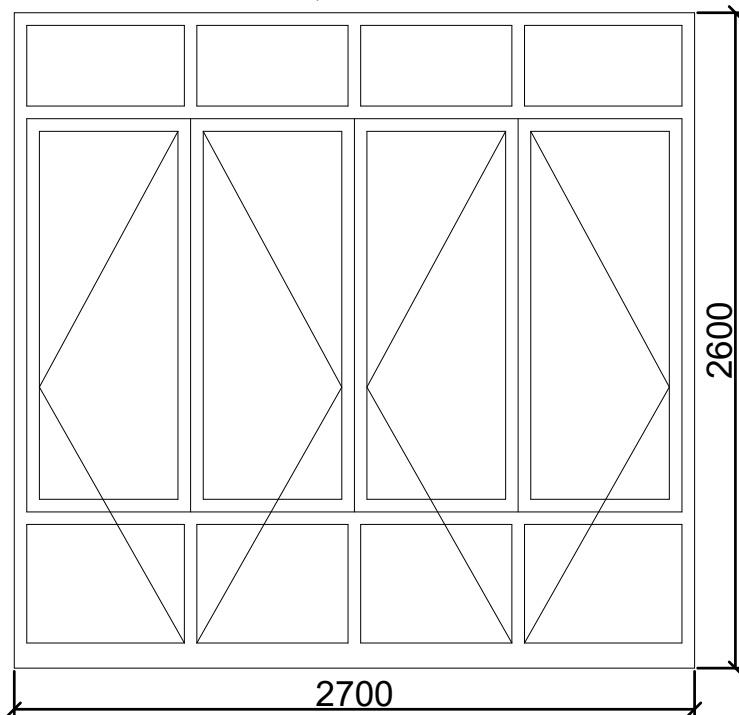

DR(H)

QUANTITY: 5

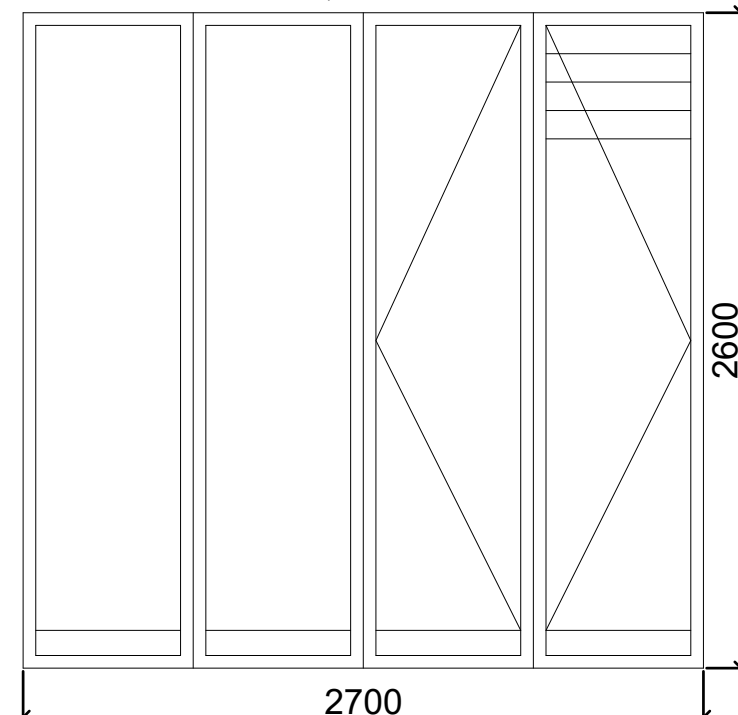

DR(I)

QUANTITY: 1

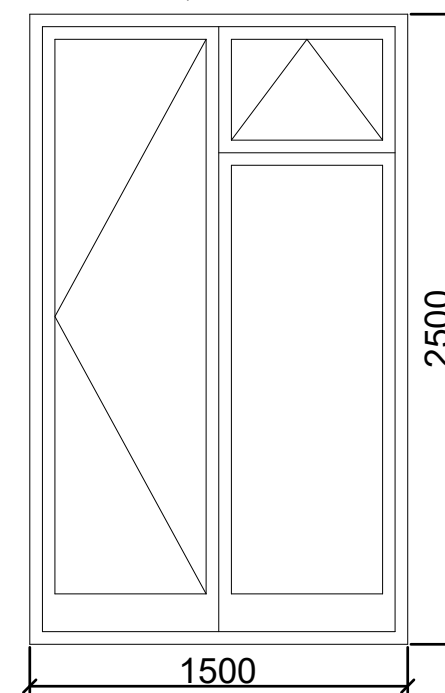

DR(J)

QUANTITY: 1

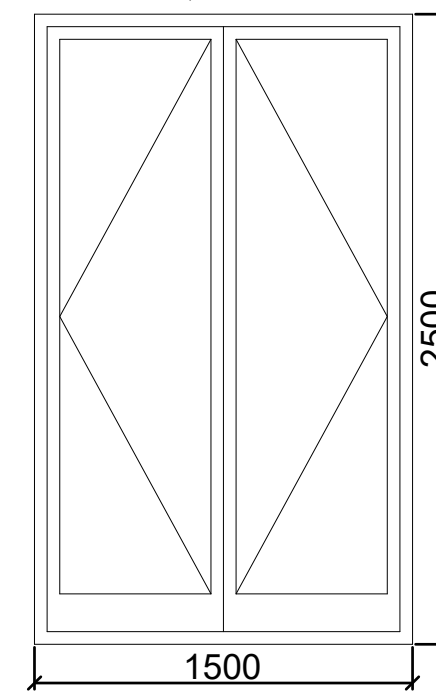

WIN(K)

QUANTITY: 14

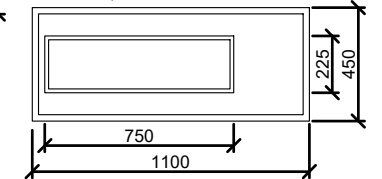

WIN(L)

QUANTITY: 1

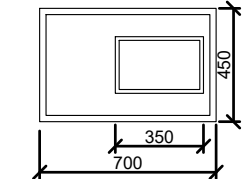

EXISTING DOOR & WINDOW SCHEDULE:

1:30

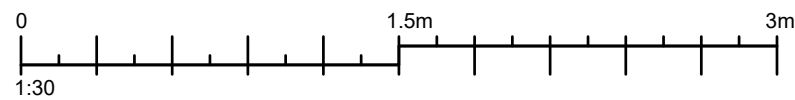

The contractor is responsible to ensure that no products are to be utilised that do not comply with relevant British and/or European Standards and/or Codes of Practice, COSH Regulations, Construction Regulations, or which are known or suspected at the time of product selection and/or construction to be deleterious to health and safety or to the durability of the work or not in accordance with good building practices.

The contractor is responsible for checking dimensions, tolerances, levels and references. This drawing is to be read in conjunction with all relevant consultants or specialists drawings. Any discrepancy is to be notified to Baily Garner LLP and rectified before proceeding with the works on site or shop drawings.

Where an item is covered by drawings to different scales, the larger scale drawing is to be worked to.

Do not scale drawings. Figured dimensions to be worked to in all cases.

This drawing and the copyrights and patents therein are the property of Baily Garner LLP and may not be used or reproduced without consent or attribution.

A3

CLIENT:
London Borough of Camden

ADDRESS:
77-105 Solent Road
London
NW6 1TY

SCALE:
1:30
JOB NO.
34656

PROJECT:
Roof and Window Replacement
Works

TITLE:
Existing Window and Door
Schedule
PURPOSE OF ISSUE:
Planning

DATE:
12/09/2023
DRAWING No.
P 11
REVISION



146-148 ELTHAM HILL
LONDON SE9 5DY
t. 020 8294 1000
f. 020 8294 1320
e. general@bailygarner.co.uk