





HOLMES ROAD

METERED PARKING BAYS

Nos 61-63

REVISIONS

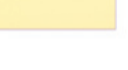
Rev.	Date	By

-  STUDENTS RECEPTION ENTRANCE
-  EXISTING STUDENT ACCOMMODATION
-  CLASS E OFFICE SPACE
-  B8 USE
-  VERTICAL CIRCULATION

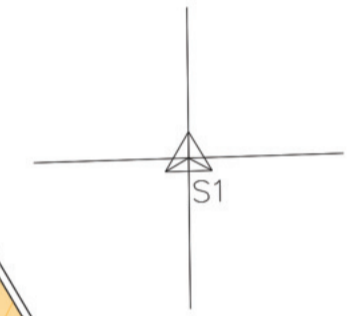

SCALE 1:100 at A1

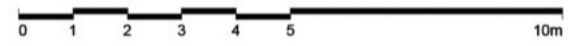

PLANNING APPLICATION

ALL DIMENSIONS TO BE CHECKED ON SITE  
 WORK TO FIGURED DIMENSIONS ONLY  
 REPORT DISCREPANCIES TO THE ARCHITECT  
 AT ONCE BEFORE PROCEEDING

Contemporary Design Solutions



46 Great Marlborough Street  
 London  
 W1F 7JW  
 Telephone: 020 7464 9000 Fax: 020 7464 4944

Client

65 HOLMES ROAD LTD

Project Title  
 ADDITION OF 8 STUDENT STUDIO UNITS  
 OVER CLASS-E OFFICE SPACE  
 65 HOLMES ROAD  
 LONDON NW5 3AN

Drawing Title

EXISTING GROUND FLOOR PLAN

Scale	1:100@A1	NTS@A3	Date	OCTOBER 2022
Drawn	EA	Checked	CT	
Drawing No.	220900(SO)100		Rev.	C

CAD plot date:

