

ELEVATION A-A

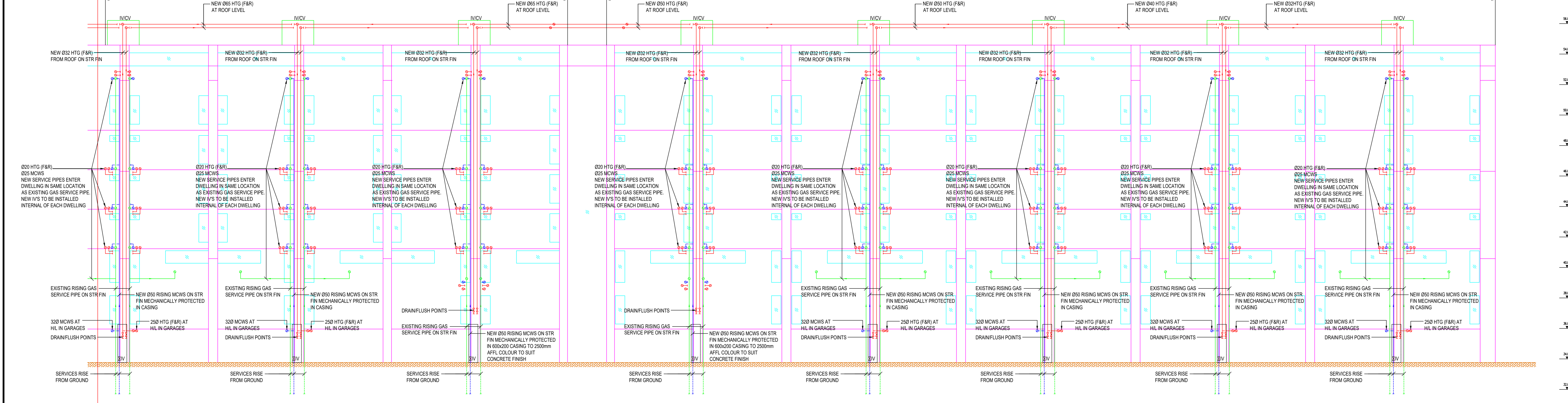

ELEVATION A-A

NOTES
1. FOR STANDARD DRAWING NOTES & LEGEND PLEASE REFER TO DRAWING NO. 3547-RW-M-020

REV	AMENDMENT	DRN	CHK	DATE
D	AMENDED TO LB COMMENTS	NS	DMX	16.03.20
C	NOTES ADDED	NS	DM	22.01.20
B	A2 AND A3 ENTRIES AMENDED	NS	DM	16.12.19

Client
Camden
ARGYLE STREET
LONDON
WC1H 8NJ

BYA BUTLER & YOUNG ASSOCIATES
Mechanical and Electrical Consulting Engineers
1st Floor, 54-62 Station Road East, Oxley, Surrey RH8 0PG
Telephone 01883 717172 Fax 01883 717174
Website www.bya.co.uk Email enquiries@bya.co.uk

Project
ALEXANDRA ROAD ESTATE
(ROWLEY WAY)

Drawing Title
PROPOSED REPLACEMENT HTG & DOM WATER SERVICES PIPE ROUTE TO EXTERNAL ELEVATION OF DWELLINGS (A1-A5)

Drawing No.
3547-RW-M-020

Dwg Sheet
A0

Drawn
NS

Checked
JS

Date
NOV 23

Scale
1:100

Rev
-

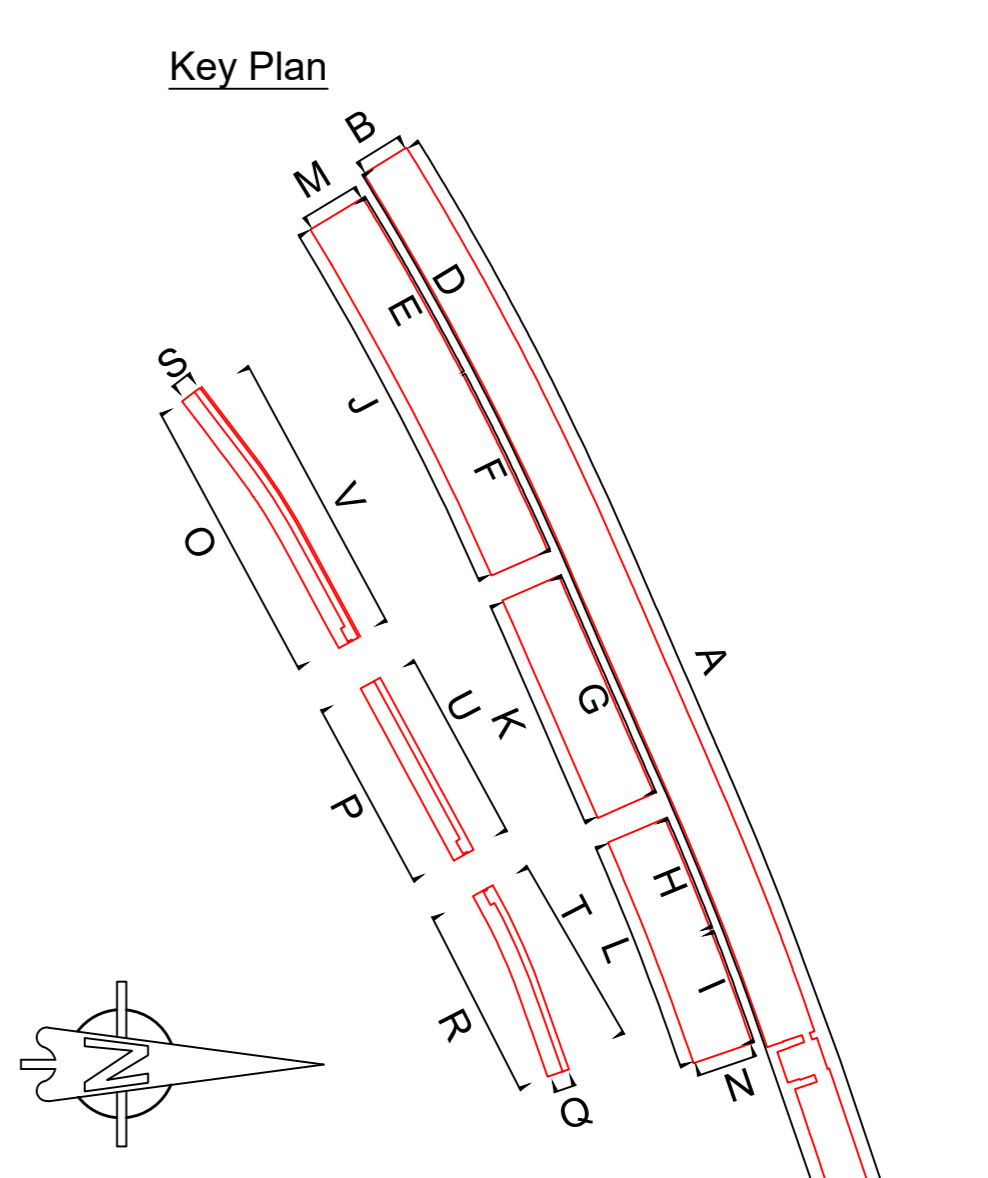

NOTES
1. ALL PIPEWORK FULLY INSULATED AND WEATHER PROTECTED WITH P.B. AND STUCCO ALUMINIUM CLADDING.

DRAWING LEGEND

	EXISTING GAS SERVICE PIPE
	NEW MAINS WATER PIPE
	NEW HEATING FLOW & RETURN PIPE

PLANNING DRAWING