



MR-ECO-COOL-V.

MRXBOXAB-ECO5-AE(OH)CV Cooling Module

Installation Manual



1.0 SAFETY INFORMATION

- The provision of the electrical supply and the connection of the unit to the mains must be carried out by a qualified electrician. Ensure that the mains supply (Voltage, Frequency and Phase) complies with the rating label.
- Isolate from power supply before removing any covers. During installation / maintenance ensure all covers are fitted before switching on the mains supply.
- All-pole disconnection from the mains as shown in the wiring diagram must be incorporated within the fixed wiring and shall have a minimum contact separation of 3mm in accordance with latest edition of the wiring regulations.
- This unit must be earthed.
- Ducting must be securely fixed with screws to the spigot to prevent access to live parts.
- If the supply cord is damaged, it must be replaced by its service agent or similarly qualified persons in order to avoid a hazard.
- When installing the unit, take care not to damage electrical or other hidden components – do not drill the unit casing.
- Precautions must be taken to avoid the back-flow of gases into the room from the open flue of gas or other fuel-burning appliances.
- The unit must be installed indoors, and away from direct sources of frost, heat and water spray or moisture generation. Ambient temperature range -5 to 40 °C.
- The cooling unit is an electro-mechanical device that contains and uses R134a refrigerant. Refrigerant weight, 0.4kg (Maximum).
- This appliance should not be used by children or persons with reduced physical, sensory or mental capabilities or lack of experience and knowledge, unless they have been given supervision or instruction concerning the safe use of the appliance by a person responsible for their safety. Children shall not play with the appliance. Cleaning and user maintenance shall not be carried out by children. This unit contains live electrical components, moving parts and refrigerant under pressure. Always site out of reach of children and protect from vandalism and accidental damage.

- Keep the unit upright during installation and level the unit in its final position. Once in final position, leave unit for a minimum of 4 hours before activation.
- Ensure that the airflow through the unit does not fall below 216 m³/h (60 l/s) during operation.
- Lifting point to be used for lifting the cooling module ONLY. It must not be used to lift the Cooling Module plus MVHR.
- Do not damage the pipes of the refrigerant circuit.
- Do not use the unit if damaged, contact after sales.
- In the event of gases escaping from damaged pipework, avoid contact with eyes.

1.1 Symbols



GENERAL WARNING

Signifies a general warning regarding hazard specified by supplementary information.



ELECTRIC SHOCK

This unit must be completely electrically isolated before any panels are removed. Check mains supply and control connections.



COMPRESSED GAS

Liquefied Gas (R134a): H280: Contains gas under pressure; may explode if heated.



REFER TO INSTRUCTION MANUAL

Read and understand the installation and maintenance manual before installing, operating or maintaining this product.

1.2 Important Information

This manual contains important information on the safe and appropriate assembly, transport, commissioning, operation, maintenance, disassembly and simple troubleshooting of the product.

While the product has been manufactured according to the accepted rules of current technology, there is still a danger of personal injury or damage to equipment if the following general safety instructions and the warnings contained in these instructions are not complied with.

- **Read these instructions completely and thoroughly before working with the product.**
- **Keep these instructions in a location where they are accessible to all users at all times.**
- **Always include the operating instructions when you pass the product on to third parties.**

1.3 Personal Protective Equipment

The following minimum Personal Protective Equipment (PPE) is recommended when interacting with Nuaire product:

- **Protective Steel Toed Shoes** - when handling heavy objects.
- **Full Finger Gloves (Marigold PU800 or equivalent)** - when handling sheet metal components.
- **Semi Fingerless Gloves (Marigold PU3000 3DO or equivalent)** - when conducting light work on the unit requiring tactile dexterity.
- **Safety Glasses** - when conducting any cleaning/cutting operation or exchanging filters.
- **Reusable Half Mask Respirators** - when replacing filters which have been in contact with normal room or environmental air.

Nuaire would always recommend a site specific risk assessment by a competent person to determine if any additional PPE is required.

2.0 HANDLING

Offloading and positioning of the equipment is the responsibility of the purchaser. Items should only be lifted by competent personnel following appropriate risk assessment.

Cooling Module Weighs 65kg. Appropriate manual handling assessments must be conducted before work can commence.

Combined weight of MRXBOXAB-ECO5-AE(OH)CV and Cooling module = 121 kg. Lifting of assembled Cooling Module + MVHR should be carried out with genie-lift or similar with assembly being supported from below.

The cooling module is supplied with a lifting point and a lifting eyelet. This is for the lifting the cooling module ONLY and should NOT be used to lift the assembled Cooling Module + MVHR.

Once the Cooling Module has been positioned and secured in place with the side and top brackets, replace the lifting eyelet with the supplied plug to ensure the unit is sealed.

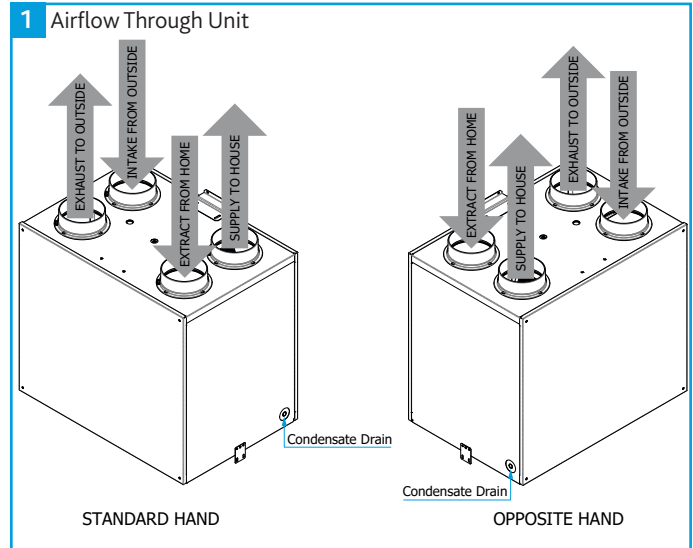

3.0 DIMENSIONS

2 Fully Assembled Dimensions

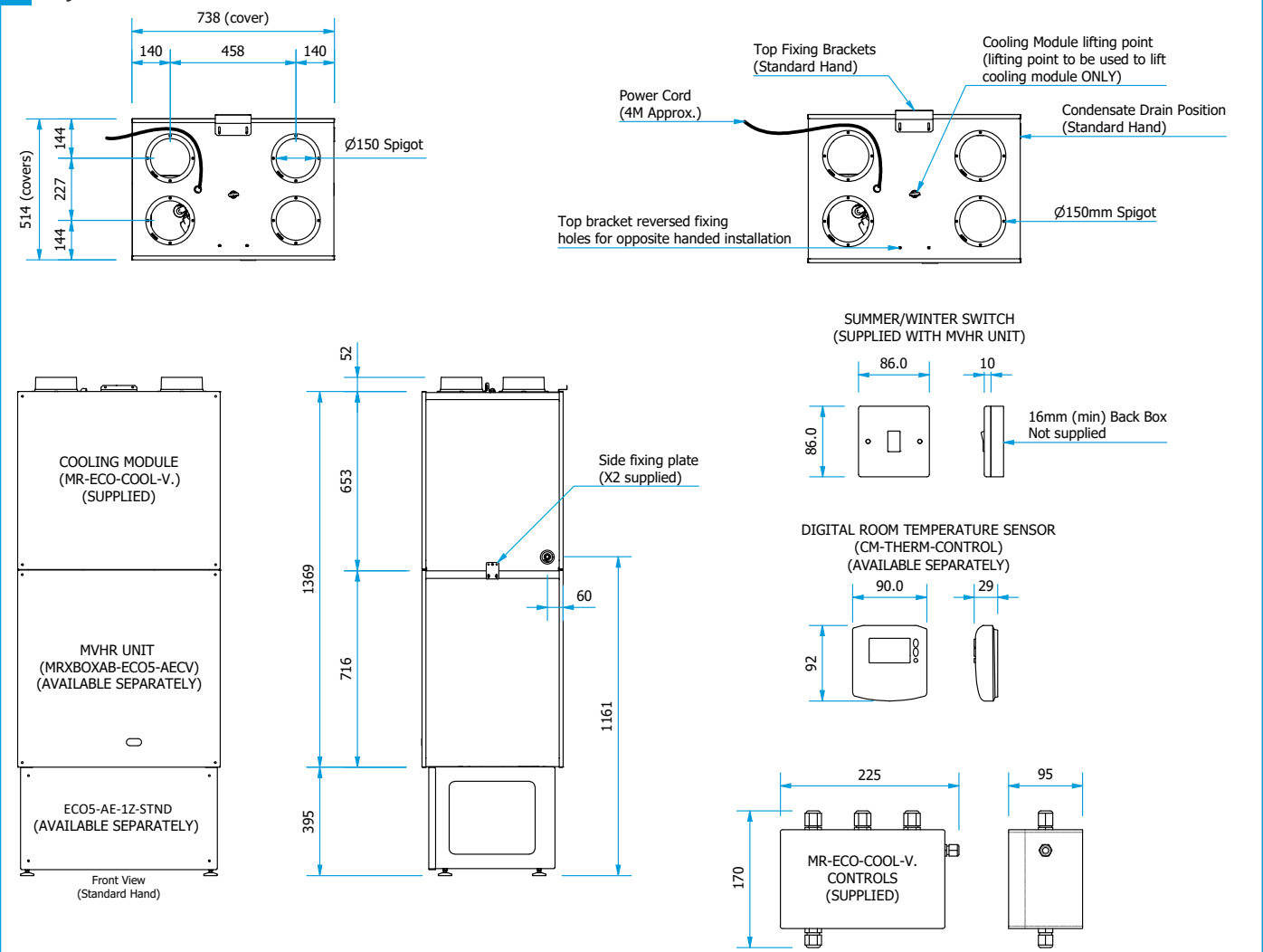

3 Mounting Bracket Dimensions

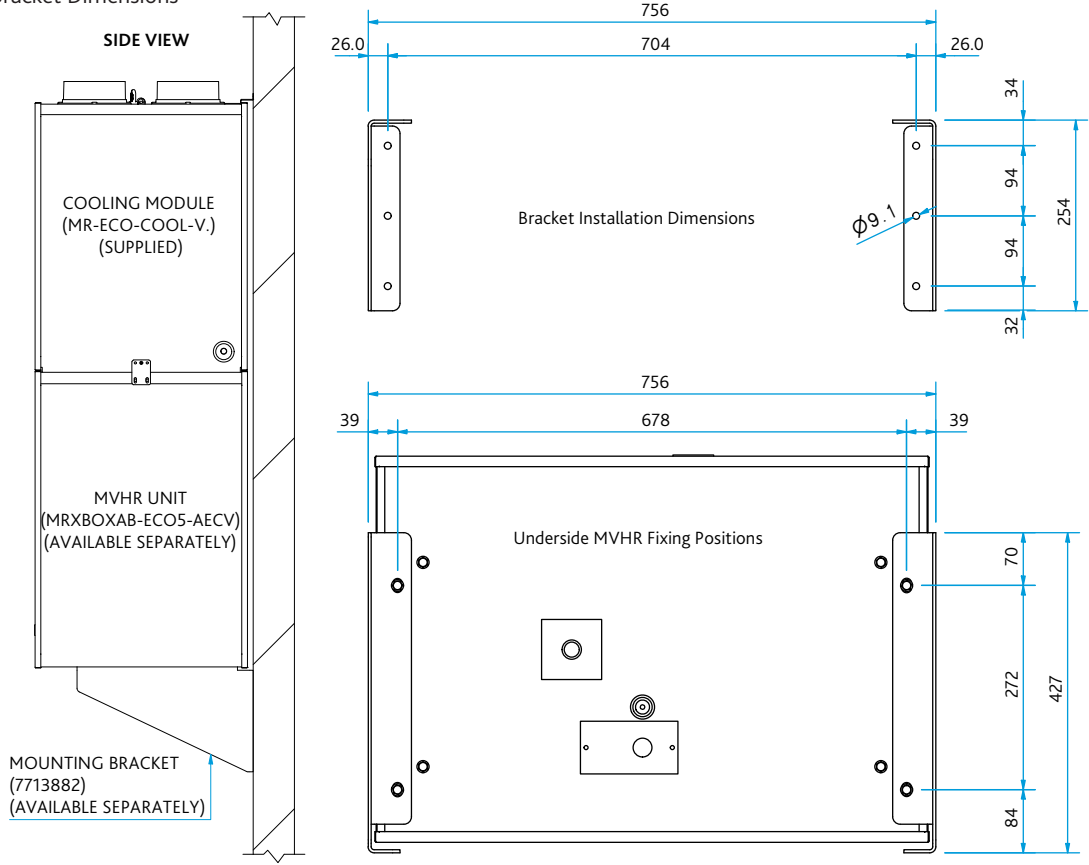

4 System Schematic

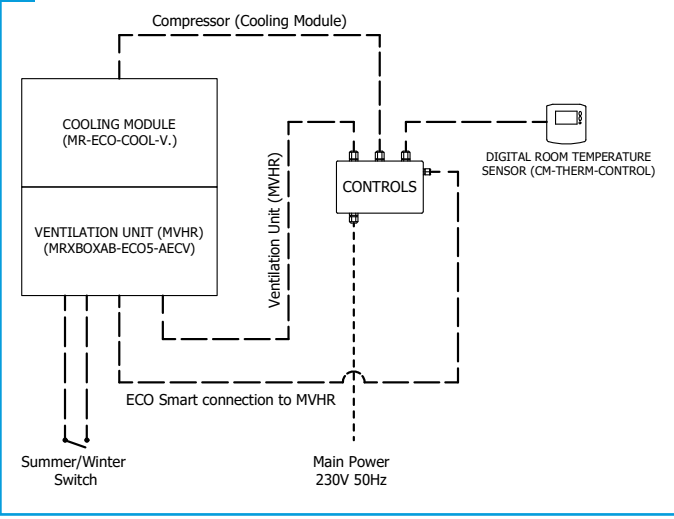

4.1 General Installation

Installation must be carried out by competent personnel in accordance with the appropriate authority and conforming to all statutory governing regulations. All mains wiring must be in accordance with the current I.E.E. Regulations, or the appropriate standards. Ensure that the mains supply (Voltage, Frequency and Phase) complies with the rating label.

ADF 2010 DVCG: "Ensure the final location of equipment offers sufficient space to allow access for maintenance. The fan unit [including cooling module] should be installed to allow sufficient space for end of life replacement of the whole unit or key mechanical/electrical components. This should be achievable without the need to remove fixed structures or significant lengths of connected ductwork." In addition to the space requirement the total weight of the fan unit and cooling module products should be considered to allow the use of mechanical lifting equipment required to safely remove and replace the product.

The unit and its controls must be installed indoors, and away from direct sources of frost, heat and water spray or moisture generation. Ambient temperature range -5 to 40°C.

This unit must be earthed.

When installing the unit, take care not to damage electrical or other hidden components – **do not drill the unit casing.**

This units contains pressurised components.

The cooling unit is an electro-mechanical device that contains and uses R134a refrigerant.

This unit contains live electrical components, moving parts and refrigerant under pressure. Always site out of reach of children and protect from vandalism and accidental damage.

Keep the unit horizontal during installation and level the unit in its final position. Once in final position, leave unit for a minimum of 4 hours before activation.

4.0 INSTALLATION

The Cooling Module (MR-ECO-COOL-V.) has been designed for use with the MRXBOXAB-ECO5-AE(OH)CV and 7713807 control only.

Isolate power supply before commencing work. Ensure the Nuair controls are electrically isolated from the mains supply.

Recommend mounting method uses the ECO5-AE-1Z-STND. Alternatively angled brackets are available (Part Number: 7713882). However, it is the responsibility of the installer to ensure the mounting surface for the brackets will adequately support the combined weight of both MVHR and Cooling module (Combined Weight = 121kg).

Airflows of less than 60 l/s may cause the in-built thermal overload protection to activate to protect the unit. Ensure airflows are balanced and commissioned in accordance with the original design criteria.

The Cooling module **MUST not be run without the specified minimum airflow. This can result in the compressor overheating and may invalidate the warranty.**

Typical installation is Floor Mounted using (ECO5-AE-1Z-STND).

4.2 Unit Installation

5 Unit Access

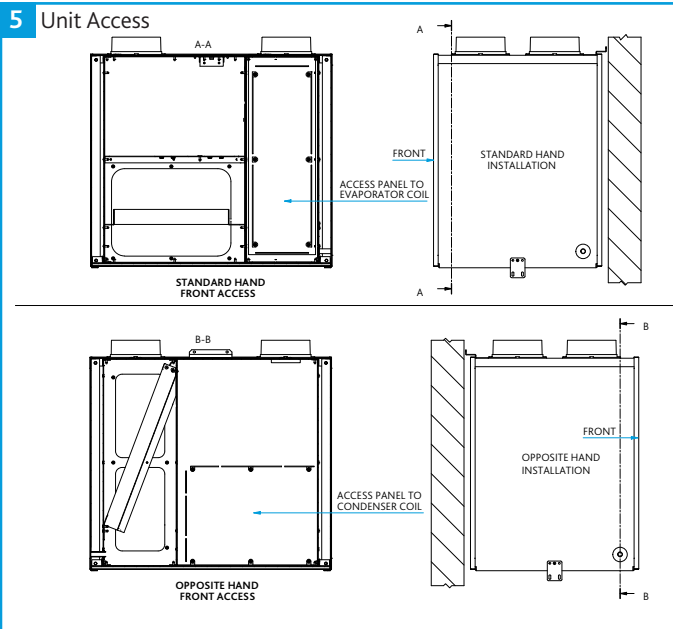

The transit bolts must be removed from the MRXBOXAB-ECO5-AE(OH)CV before placing the Cooling Module on top of the MVHR unit.

Where the MRXBOXAB-ECO5-AECV and MR-ECO-COOL-V. are assembled prior to transport to site, such as in a packaged utility cupboard, the installer must ensure that the combined assembly is secured and transported in the upright position.

Following the MRXBOXAB-ECO5-AE(OH)CV being levelled and installed on an ECO5-AE-1Z-STND, the supplied gaskets must be installed as shown in Figure 6. Remove the backing paper of the foam gaskets and whilst aligned with the holes of the MVHR unit fit each gasket adhesive side down.

Lift the cooling module (section) above the MVHR unit and lower into place. **Do not drag the unit over the foam gaskets as this may damage foam gaskets.**

Once in position secure the side brackets with the fixings supplied (fitted to the units) and secure the top of the unit to a suitable surface with the adjustable top bracket supplied (Figure 6).

6 Foam Gasket Installation

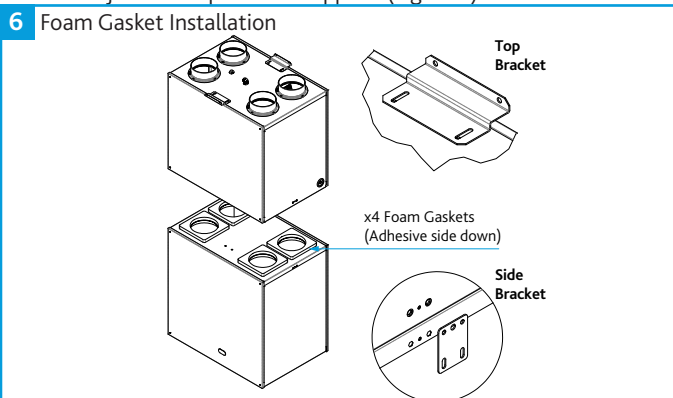

4.2.1 Opposite Handed Units

The Cooling Module can be installed on opposite handed MVHR units by rotating the module 180°. In doing this the drain, fly lead and access to coils will be flipped to the opposite side. The drain position will be located towards the front at the bottom of the unit.

4.3 Condensate Drain Installation

The unit provides an external 15mm Ø condensate drain pipe fitted flush to the outer case to minimise its foot print. Conventional push on plumbing connections, connect to the drain (MAX Outer Diameter of fitting: 37mm).

Ensure the cooling module is installed level.

If the condensate pipe is fitted in an unheated space the pipe should be in insulated to prevent freezing. Ensure the cooling module has its own dry trap separate to the MVHR.

7 "T" Piece CONTRAP & MVHR Drain Connection

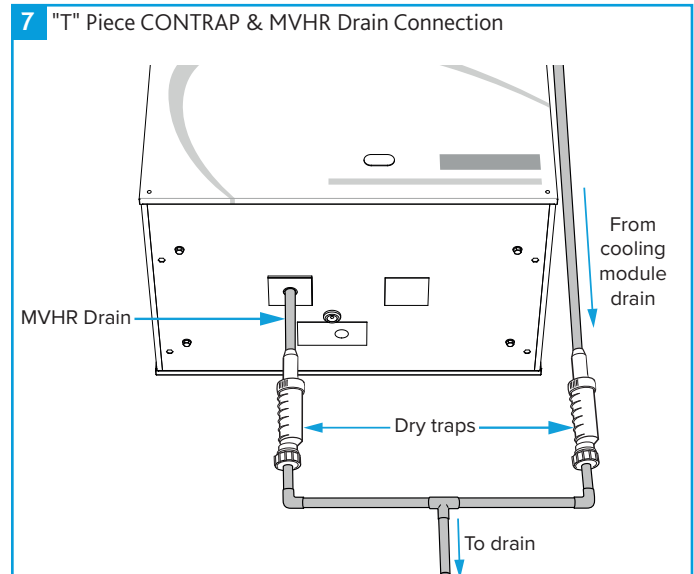

When using a "T" Piece to connect the CONTRAP drainage and the MVHR drain pipework the MVHR drain must always be fitted before the "T" Piece to prevent condensate from feeding back into the MVHR system.

4.3.1 Standard Hand Installation

The drain is positioned at the rear bottom corner on the right-hand side panel on a standard hand unit.

4.3.2 Opposite Hand Installation

The unit is rotated 180°, positioning of the drain towards the front, at the bottom corner on the left-hand side panel.

8 Condensate Pipe Connection

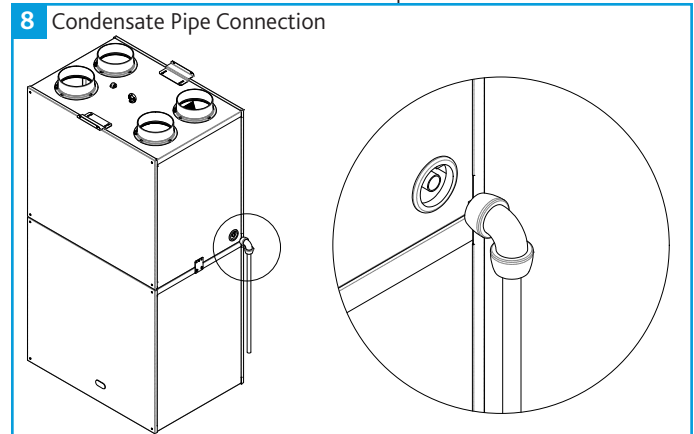

5.0 DUCTING

Before commencing ducting installation reference should be made to building regulations document "Domestic ventilation compliance guide". This document supports ADF2010 and details installation, testing and commissioning of all ventilation systems.

It is recommended that rigid ducting must be used it all times. Fresh-air Intake and stale air Exhaust ducts will carry cold air in winter. Supply air duct will carry cold air when Cooling Module is operating. Therefore Intake, Exhaust and supply ducts will be at risk of condensation forming on external surfaces and should all be thermally insulated.

Any duct component including ancillaries such as carbon filters must be insulated if they are carrying colder air produced by the cooling module. Flexible connections should be avoided. Nuair Ductmaster thermal ducting should be used on Intake, Exhaust and Supply duct runs. If flexible connections cannot be avoided, FLD1150 Insulated Flexible Duct should be used.

Ducting must be installed in such a way that resistance to airflow is minimised. Bends should be kept to a minimum.

Ducting joints must be sealed with suitable duct sealant and needs to be taped. Ducting shall be adequately and reliably fixed.

Ducting to cooling module must be securely fixed with screws to the spigots to prevent access to live parts.

6.0 SUPPLY TEMPERATURES

Supply air temperature is critical to ensure good cooling distribution.

There is a possibility of condensation forming on grilles or valves at low airflows. If this occurs the airflow should be increased.

7.0 ELECTRICAL INSTALLATION

Electrical Details
Voltage: 230V 1ph 50Hz
Running Current: 3.5 A
This unit must be earthed.

7.1 Wiring Diagrams

7.2 Unit

9 Unit Wiring Diagram

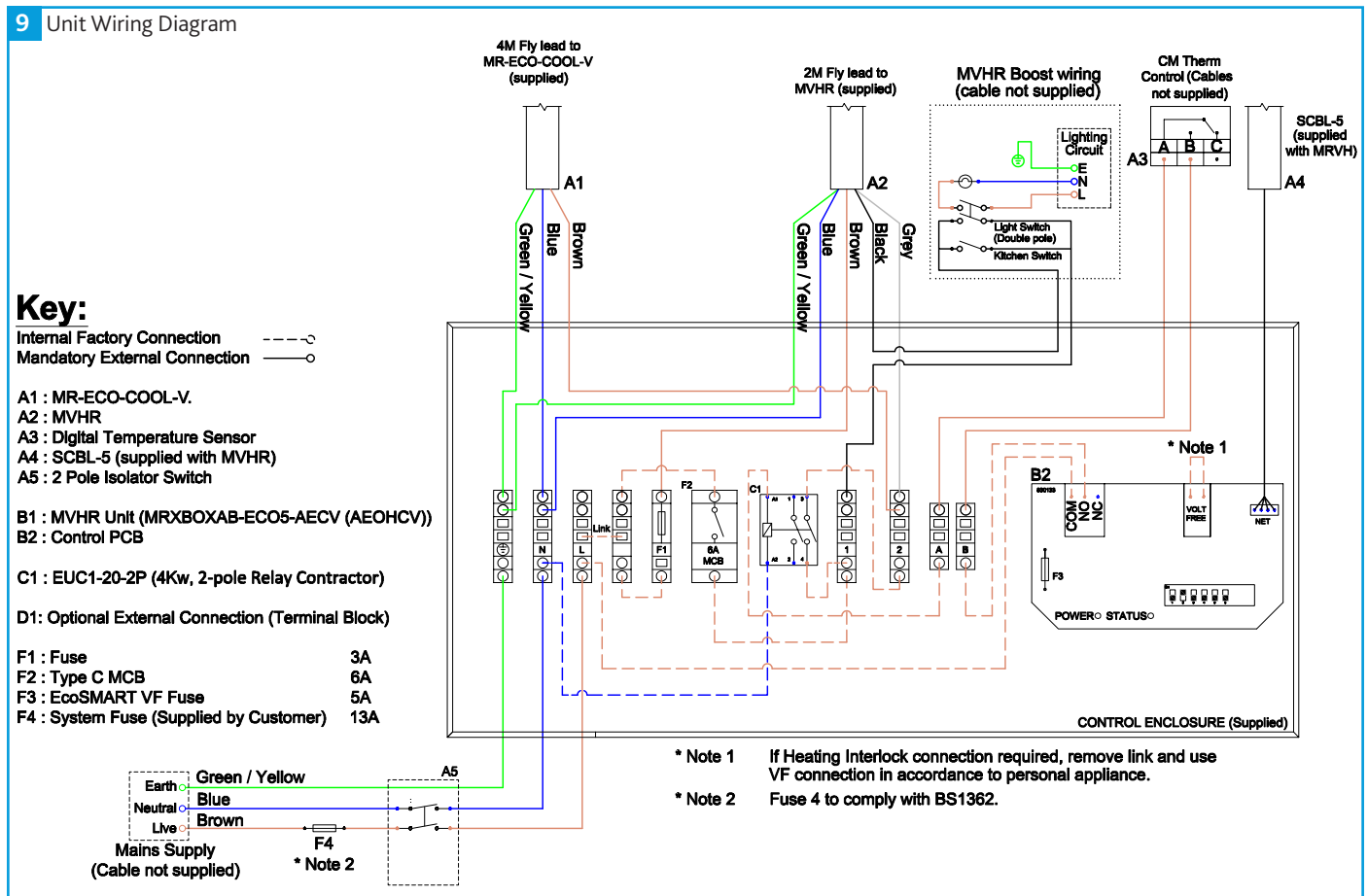

7.2.1 Summer / Winter Switch (Supplied with MVHR)

10 Wiring Diagram - Summer / Winter Switch

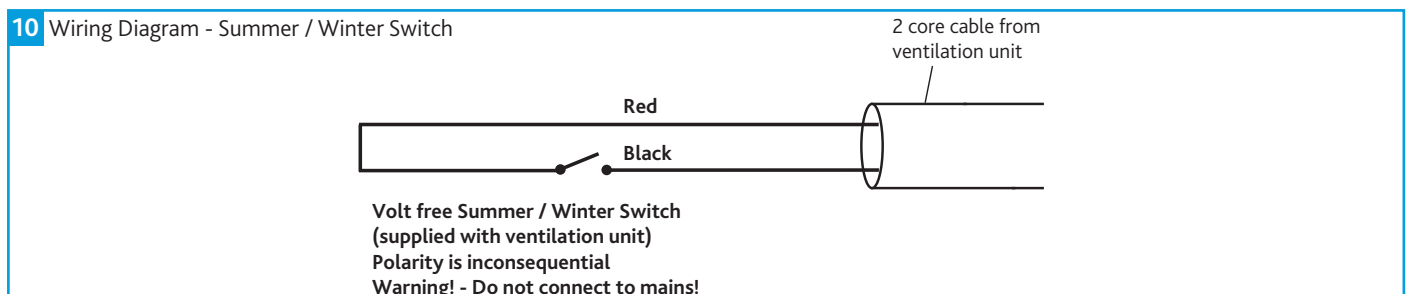

8.0 CONTROLS / DESCRIPTION OF OPERATION

- MVHR will run continuously at Background/Whole dwelling duty (Speed 1) unless it receives a 230v signal to Switched-Live input connections SL1 or SL2.
- Cooling module will be enabled to run and MVHR enabled to speed 3 by a 230v Switched live from wall mounted temperature sensor CM-THERM-CONTROL (supplied).
- The wall mounted temperature sensor will control the cooling module and MVHR unit. On reaching the set point (user defined) the Cooling Module will operate and the MVHR will increase to speed 3. For energy efficient operation, the set point should be adjusted to 23 deg C. Note that the wall mounted temperature sensor also features an ECO mode which is pre-set to 23°C (not adjustable) and can be set to operate between 1 and 24 hours by the user. **Switching the wall mounted temperature sensor (CM-THERM-CONTROL) off will disable the cooling module.**
- It is recommended that, if possible, the cooling unit be interlocked with the heating system to prevent triggering when heat is being called for. Figure 9 shows connection to a heating system which is normally closed via a link. This can be replaced by a suitable VOLT FREE connection to the heating device.
- Summer/Winter switch (Supplied with MVHR). Should be set to summer mode when cooling is expected to run.
- Summer mode can be selected year round to attempt to mitigate overheating caused by solar gains but must be selected when cooling is expected to run (summer months).
- Winter mode ensures the MVHR will recover heat at all times.
- **For further details, see MRXBOXAB-ECO5-AE(OH)CV installation manual (671861).**

9.0 COMMISSIONING

To ensure the cooling module operates correctly and prevent the thermal overload protection from tripping, there must be a minimum airflow of 216 m³/h (60 l/s).

It is recommended the ventilation unit is set to speed 3 on supply and extract, potentiometers are set to maximum (fully clockwise).

To commission the MVHR unit providing the air flow through the cooling module, please refer to MRXBOXAB-ECO5-AE(OH)CV installation manual (Document number 671861).

10.0 MAINTENANCE

Isolate before commencing work, make sure that the unit, switched live and Nuaire control are electrically isolated from the mains supply and switched live supply.

It is important that maintenance checks are recorded and that the schedule is always adhered to. In all cases, the previous report should be referred to.

10.1 Access

Access to both Coils for cleaning can be gained by removing the front cover of the outer case and the inner covers of the Cooling Module.

Depending on the orientation of the unit (standard or opposite hand) access will be given to one of the two coils. To access the second coil an internal access panels must be removed.

The compressor requires no maintenance.

10.2 Annual Maintenance - Evaporator and Condenser Coils

- Inspect all coils for signs of damage or dirt. Loose dirt may be removed by using a soft brush, taking care not to brush the dirt into the coil, blocking the fins. Damaged fins should be combed out using a coil comb.
- If the coil is excessively dirty check that MVHR filters are still in place.
- MVHR Filters are to be inspected every 6 months and replaced every 12 months (or sooner if required).
- If the coil is excessively dirty, use a proprietary cleaning agent, e.g. HYDRO-COIL or MULTISOLVE.
- Inspect the condensate drain tray and clean as required.
- Check all electrical connections for tightness.
- Switch on the power to the unit. Check the operation of the mechanical cooling system.
- Check that all the panels are in place and that the unit is in a clean condition.
- In the event the cooling module is not operating initially inspect the MCB in the controls.

10.2.1 Refrigeration Circuit Components

All repair and replacement work on refrigeration components must be carried out by a fully qualified refrigeration engineer, trained in maintenance and refrigeration recovery, and with a sound knowledge of all relevant safety regulations pertaining to the job.

All refrigerant in the unit must be reclaimed and disposed of safely.

11.0 WARRANTY

The warranty starts from the day of delivery and includes parts only.

This warranty is void if the equipment is modified without authorisation, is incorrectly applied, misused, disassembled, or not installed, commissioned and maintained in accordance with the details contained in this manual and general good practice. **Only genuine Nuaire parts and filters may be used to maintain the unit. Failure to maintain the unit as recommended will invalidate the warranty.**

The product warranty applies to the UK mainland and in accordance with Clause 14 of our Conditions of Sale. Customers purchasing from outside of the UK should contact Nuaire International Sales office for further details.

12.0 END-OF-LIFE AND RECYCLING

Where possible Nuaire use components which can be largely recycled when the product reaches its end-of-life:

- Fans, motors, controls, actuators, cabling and other electrical components can be segregated into WEEE recycling streams.
- Sheet metal parts, aluminium extrusion, heating/cooling coils and other metallic items can be segregated and fully recycled.
- EPP, plastic ducting, nylon corner pieces, plastic heat exchangers, packaging material and other plastic components can be segregated into mixed plastic and widely recycled.
- Cardboard packaging, wood, used filters and other paper components can be largely recycled or fully processed in energy from waste centres.
- Remaining Items can be further segregated and processed in accordance with the zero waste hierarchy. Please call After Sales Support for further information on items not listed above.

Ensure that Nuaire product is made safe from any electrical / water / refrigerant supplies before dismantling commences. This work should only be undertaken by a qualified person in accordance with local authority regulations and guidelines, taking into account all site based risks.

13.0 AFTER SALES ENQUIRIES

For technical assistance or further product information, including spare parts and replacement components, please contact the After Sales Department. Before calling please establish the serial number of the unit (**this information will be available on the unit label**).

Telephone 02920 858 400
aftersales@nuaire.co.uk

Technical or commercial considerations may, from time to time, make it necessary to alter the design, performance and dimensions of equipment and the right is reserved to make such changes without prior notice.