

2.0 Photographic Survey

| 2.11 Stair Core 2: Third Floor

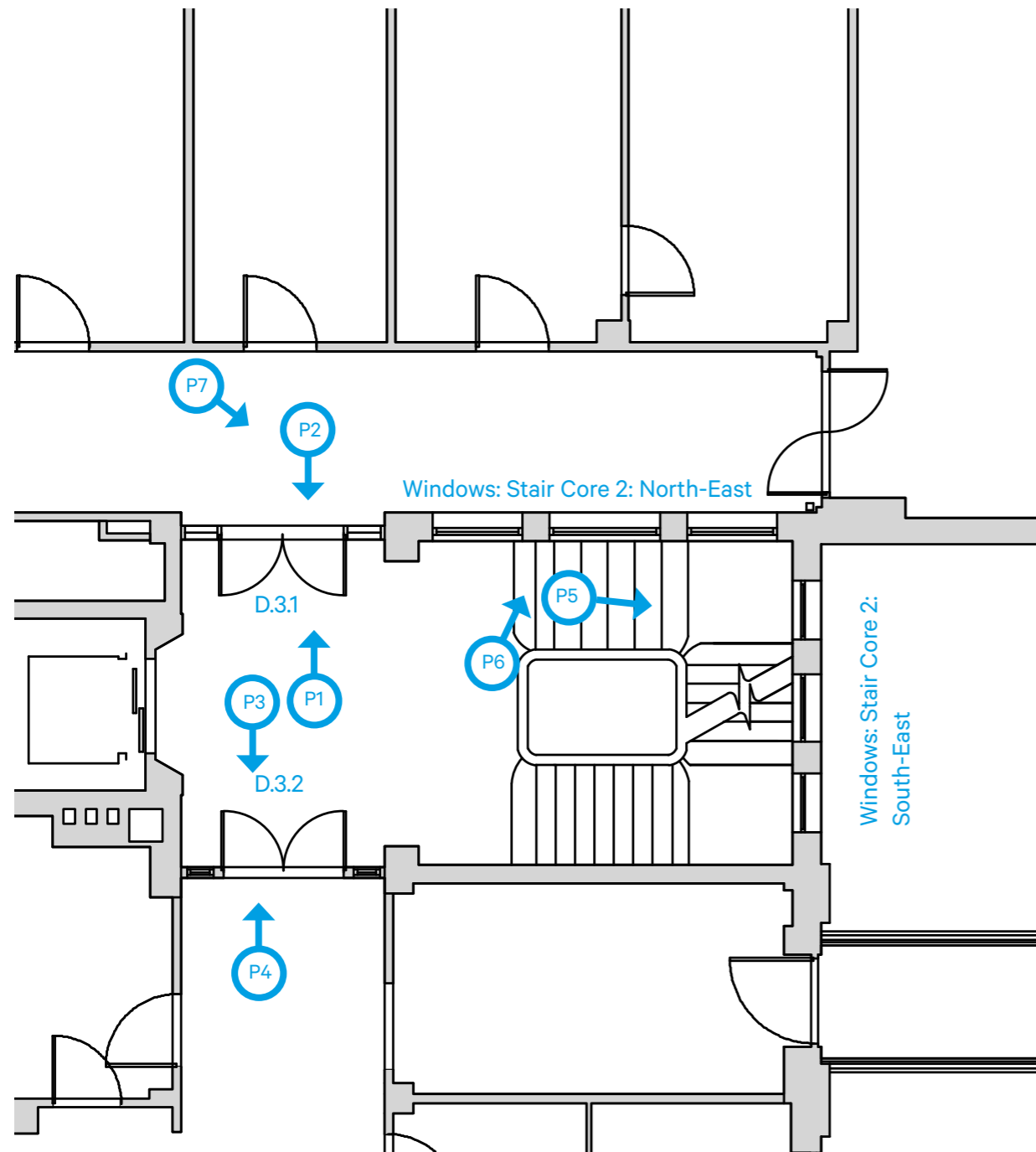

Plan of Stair Core 2: Third Floor

2.0 Photographic Survey

| 2.11 Stair Core 2: Third Floor



Photograph P1: Existing Door D.3.1 (Stair Core Side)



Photograph P2 Existing Door D.3.1 (Corridor Side)



Photograph P3: Existing Door D.3.2 (Stair Core Side)



Photograph P4: Existing Door D.3.2 (Corridor Side)

2.0 Photographic Survey

| 2.11 Stair Core 2: Third Floor



Photograph P5: Stair Core 2 South-East Elevation: Existing Windows Above Third Floor

2.0 Photographic Survey

| 2.11 Stair Core 2: Third Floor



Photograph P6: Stair Core 2 North-East Elevation: Existing Windows at Third Floor (Stair Core Side)



Photograph P7: Stair Core 2 North-East Elevation: Existing Windows at Third Floor (Corridor Side)

2.0 Photographic Survey

| 2.12 Stair Core 3: Lower Ground Floor

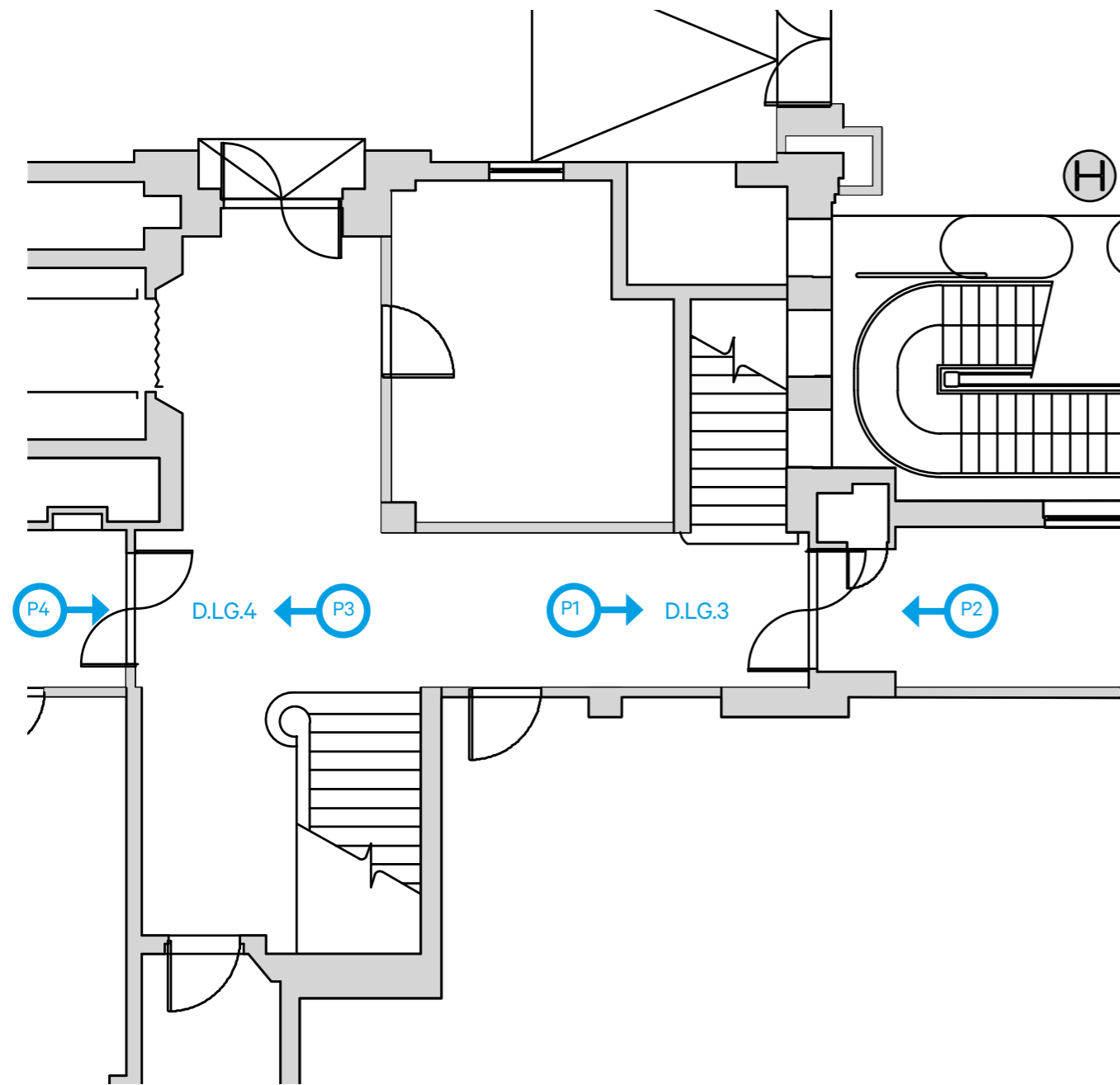

Plan of Stair Core 3: Lower Ground Floor

2.0 Photographic Survey

| 2.12 Stair Core 3: Lower Ground Floor



Photograph P1: Existing Door D.LG.3 (Stair Core Side)



Photograph P2 Existing Door D.LG.3 (Corridor Side)



Photograph P3: Existing Door D.LG.4 (Stair Core Side)



Photograph P4: Existing Door D.LG.4 (Corridor Side)

2.0 Photographic Survey

| 2.13 Stair Core 3: Ground Floor

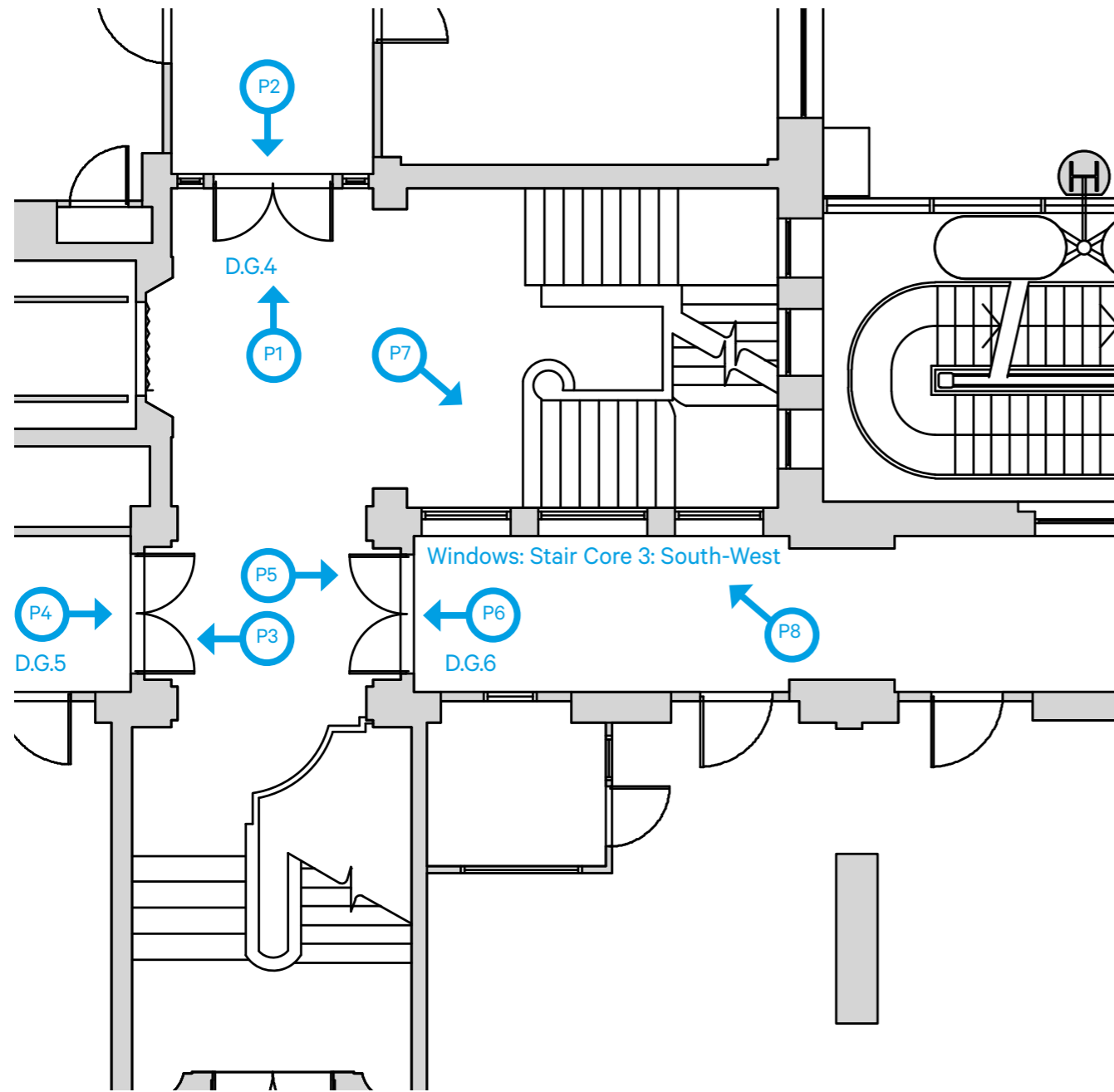

Plan of Stair Core 3: Ground Floor

2.0 Photographic Survey

| 2.13 Stair Core 3: Ground Floor



Photograph P1: Existing Door D.G.4 (Stair Core Side)



Photograph P2: Existing Door D.G.4 (Corridor Side)

2.0 Photographic Survey

| 2.13 Stair Core 3: Ground Floor



Photograph P3: Existing Door D.G.5 (Stair Core Side)



Photograph P4 Existing Door D.G.5 (Corridor Side)



Photograph P5: Existing Door D.G.6 (Stair Core Side)

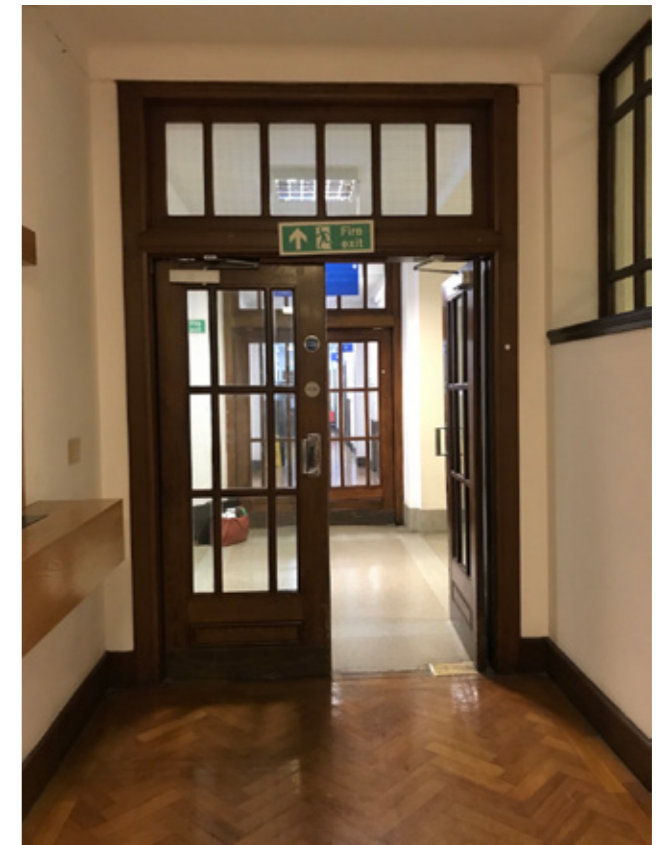

Photograph P6: Existing Door D.G.6 (Corridor Side)

2.0 Photographic Survey

| 2.13 Stair Core 3: Ground Floor



Photograph P7: Stair Core 3 South-West Elevation: Existing Windows at Ground Floor (Stair Core Side)



Photograph P8: Stair Core 3 South-West Elevation: Existing Windows at Ground Floor (Corridor Side)

2.0 Photographic Survey

| 2.14 Stair Core 3: First Floor

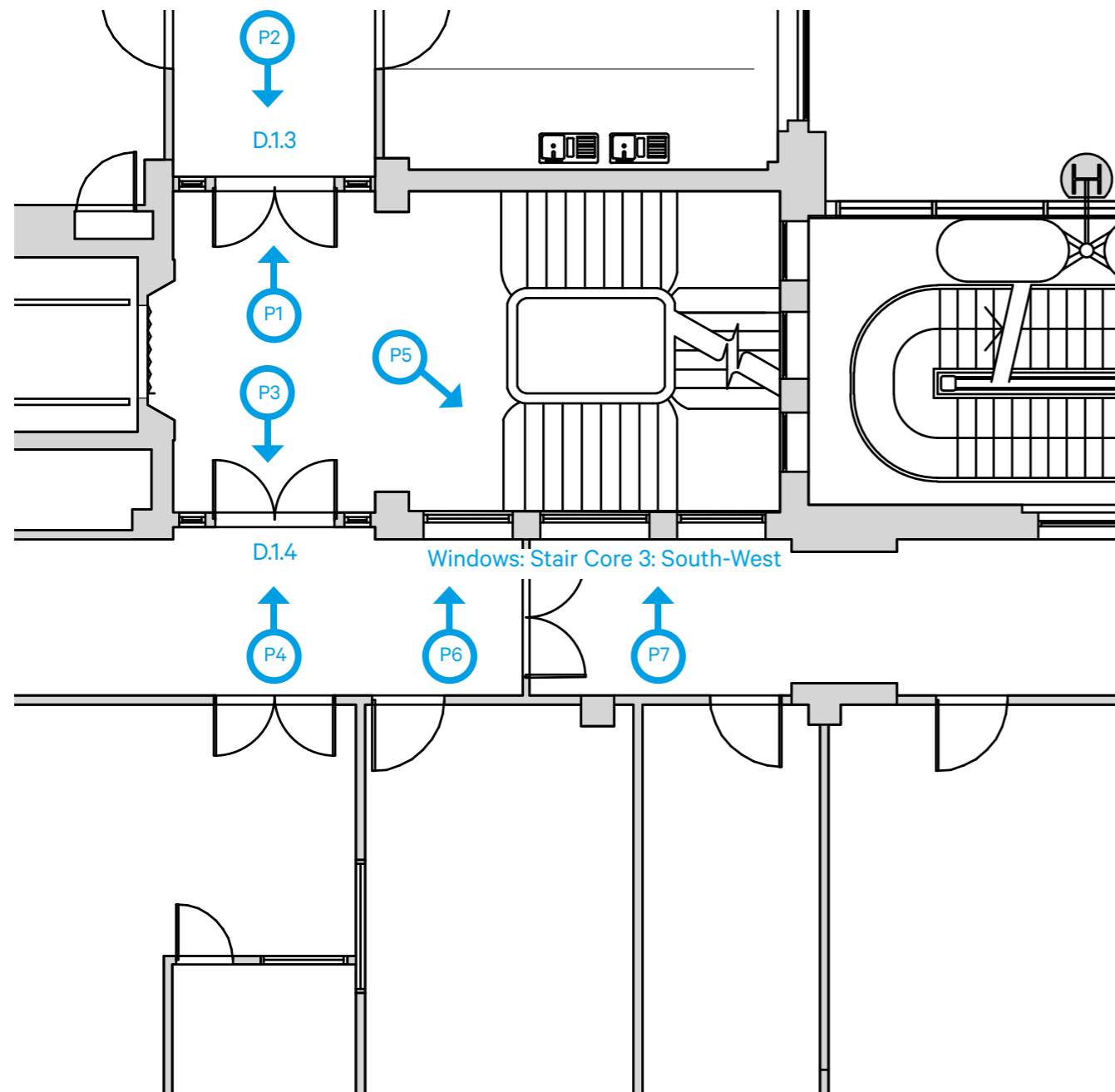

Plan of Stair Core 3: First Floor

2.0 Photographic Survey

| 2.14 Stair Core 3: First Floor



Photograph P1: Existing Door D.1.3 (Stair Core Side)



Photograph P2: Existing Door D.1.3 (Corridor Side)



Photograph P3: Existing Door D.1.4 (Stair Core Side)



Photograph P4: Existing Door D.1.4 (Corridor Side)

2.0 Photographic Survey

| 2.14 Stair Core 3: First Floor



Photograph P5: Stair Core 3 South-West Elevation: Existing Windows at First Floor (Stair Core Side)

2.0 Photographic Survey

| 2.14 Stair Core 3: First Floor



Photograph P6: Stair Core 3 South-West Elevation: Existing Windows at First Floor (Corridor Side)



Photograph P7: Stair Core 3 South-West Elevation: Existing Windows at First Floor (Corridor Side)

2.0 Photographic Survey

| 2.15 Stair Core 3: Third Floor

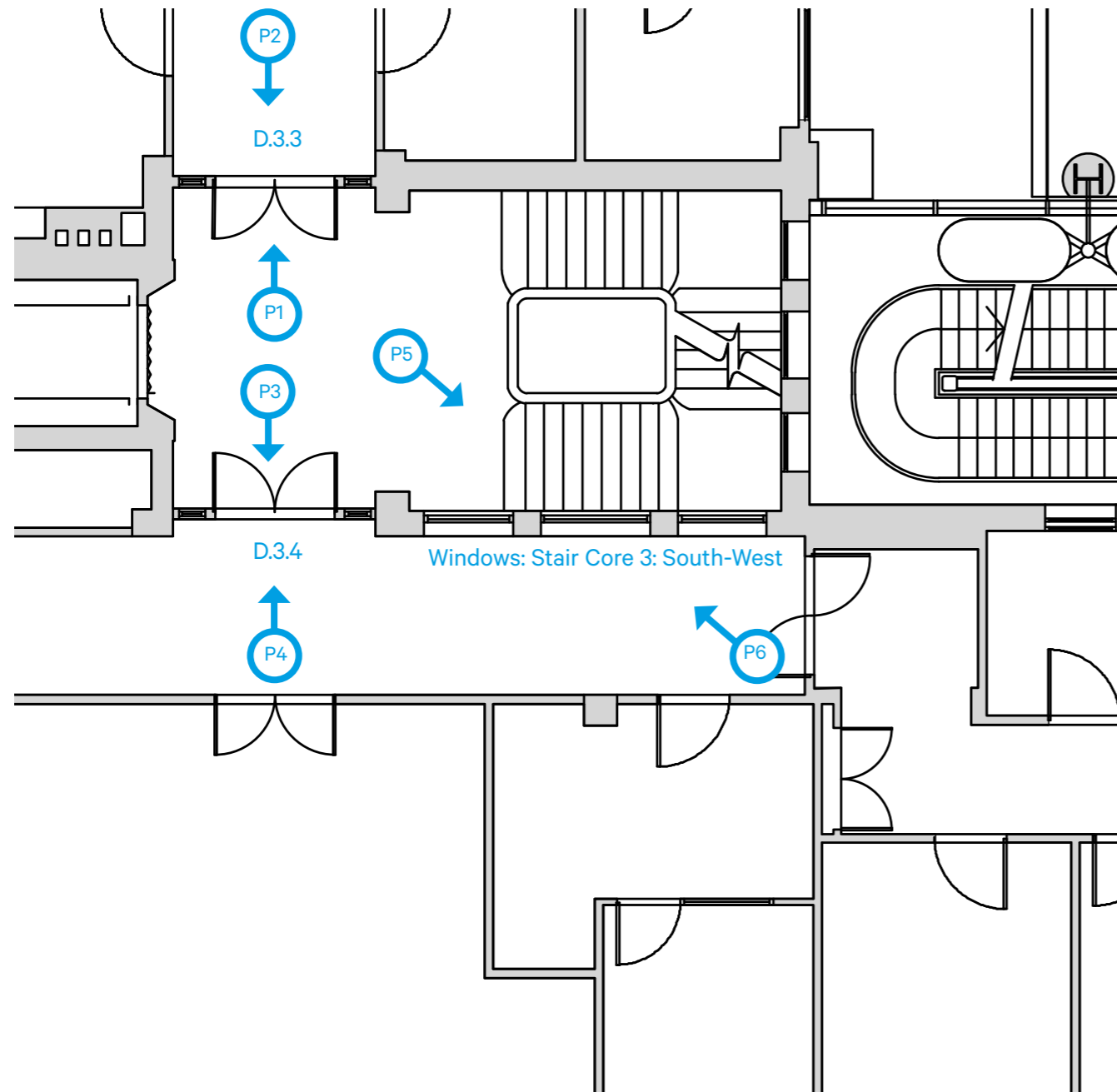

Plan of Stair Core 3: Third Floor

2.0 Photographic Survey

| 2.15 Stair Core 3: Third Floor



Photograph P1: Existing Door D.3.3 (Stair Core Side)



Photograph P2: Existing Door D.3.3 (Corridor Side)



Photograph P3: Existing Door D.3.4 (Stair Core Side)



Photograph P4: Existing Door D.3.4 (Corridor Side)

2.0 Photographic Survey

| 2.15 Stair Core 3: Third Floor



Photograph P5: Stair Core 3 South-West Elevation: Existing Windows at Third Floor (Corridor Side)



Photograph P6: Stair Core 3 South-West Elevation: Existing Windows at Third Floor (Corridor Side)

2.0 Photographic Survey

| 2.16 Ground Floor Circulation Corridors

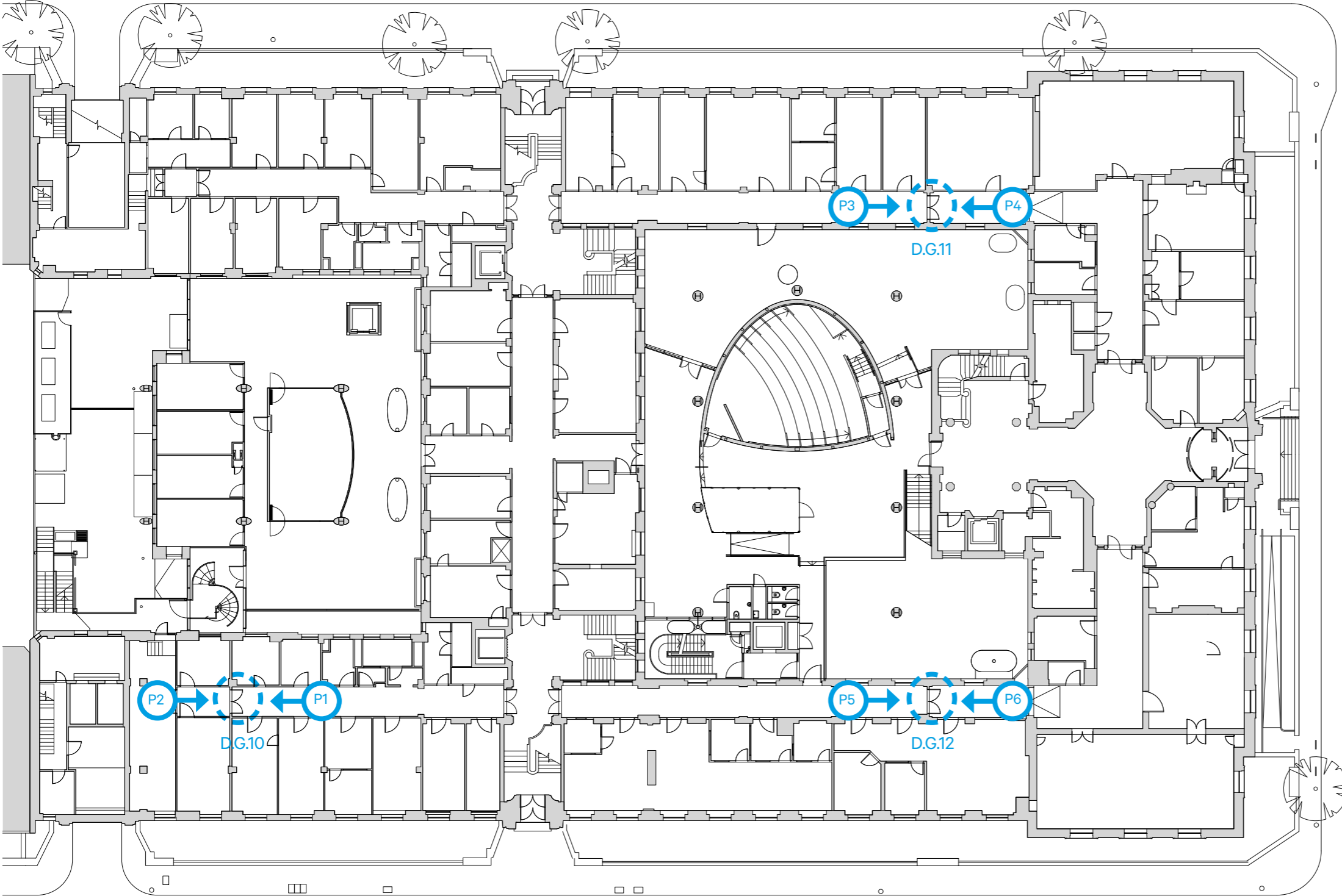

Existing Ground Floor Layout

2.0 Photographic Survey

| 2.16 Ground Floor Circulation Corridors



Photograph P1: Existing Door D.G.10



Photograph P2: Existing Door D.G.10

2.0 Photographic Survey

| 2.16 Ground Floor Circulation Corridors



Photograph P3: Existing Door D.G.11



Photograph P4: Existing Door D.G.11

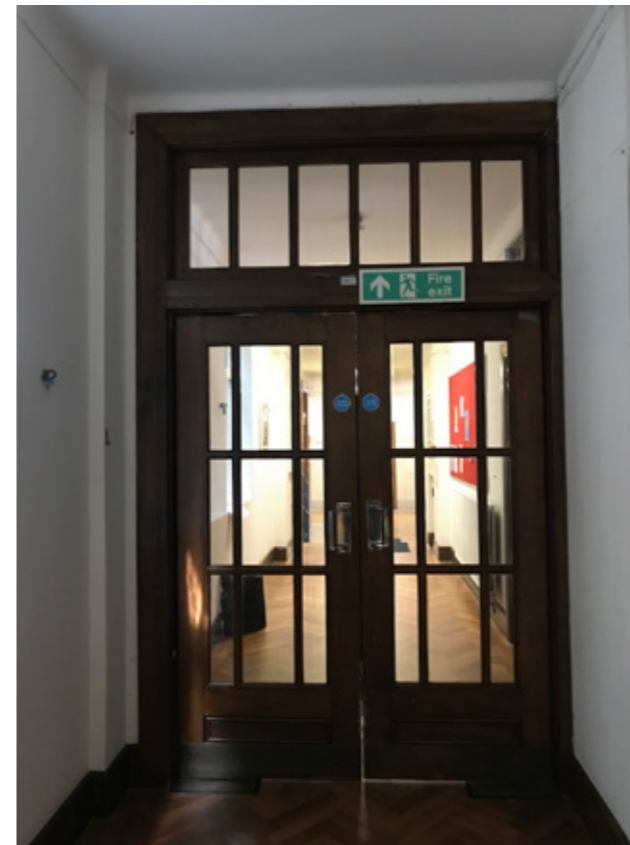

Photograph P5: Existing Door D.G.12



Photograph P6: Existing Door D.G.12

2.0 Photographic Survey

| 2.17 First Floor Circulation Corridors

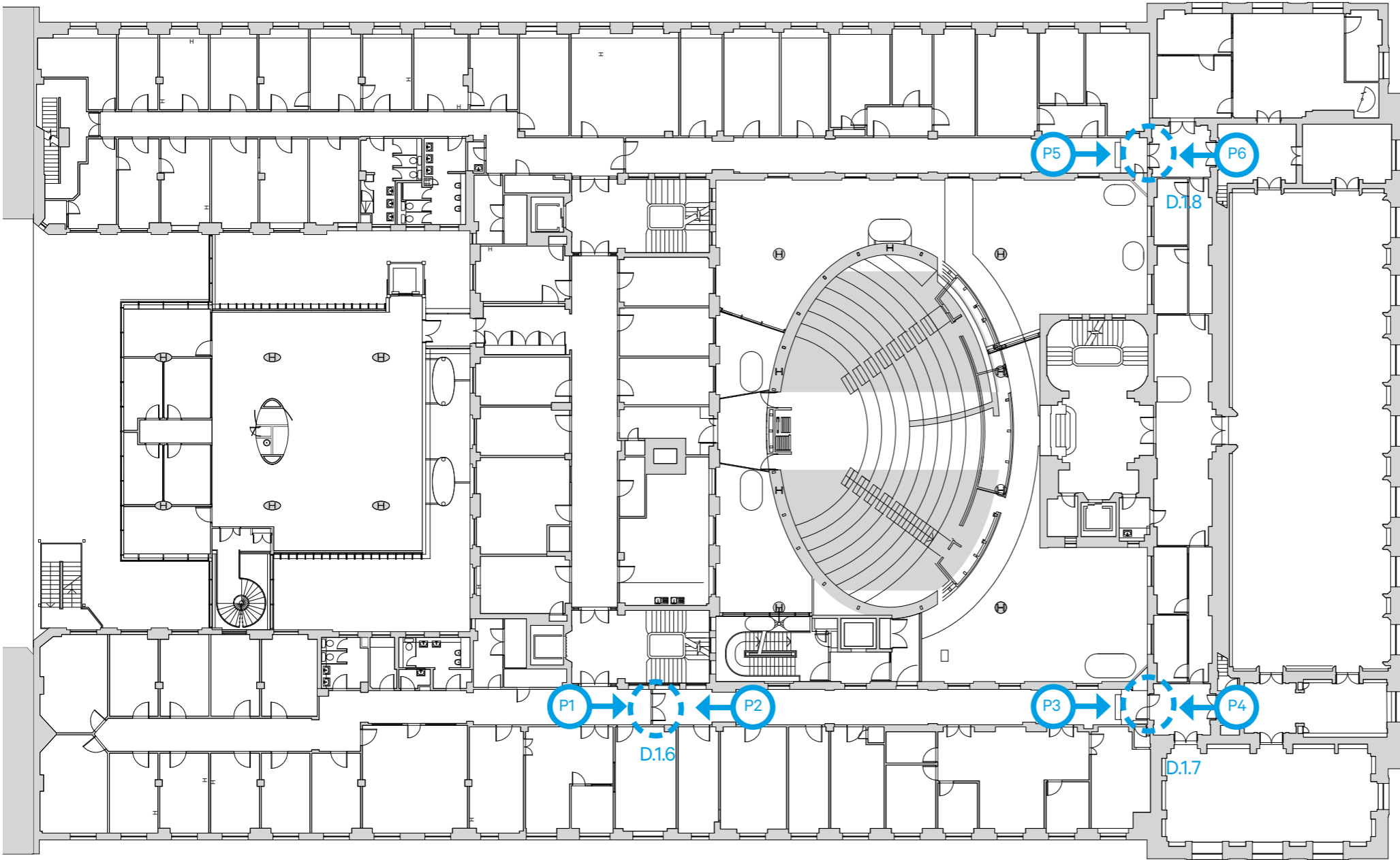

Existing First Floor Layout

2.0 Photographic Survey

| 2.17 First Floor Circulation Corridors



Photograph P1: Existing Door D.16



Photograph P2: Existing Door D.16

2.0 Photographic Survey

| 2.17 First Floor Circulation Corridors



Photograph P3: Existing Door D.17
(Corridor Side)



Photograph P4: Existing Door D.17 (Library
Lobby Side)



Photograph P5: Existing Door D.18
(Corridor Side)



Photograph P6: Existing Door D.18 (Library
Lobby Side)

2.0 Photographic Survey

| 2.18 Second Floor Circulation Corridors

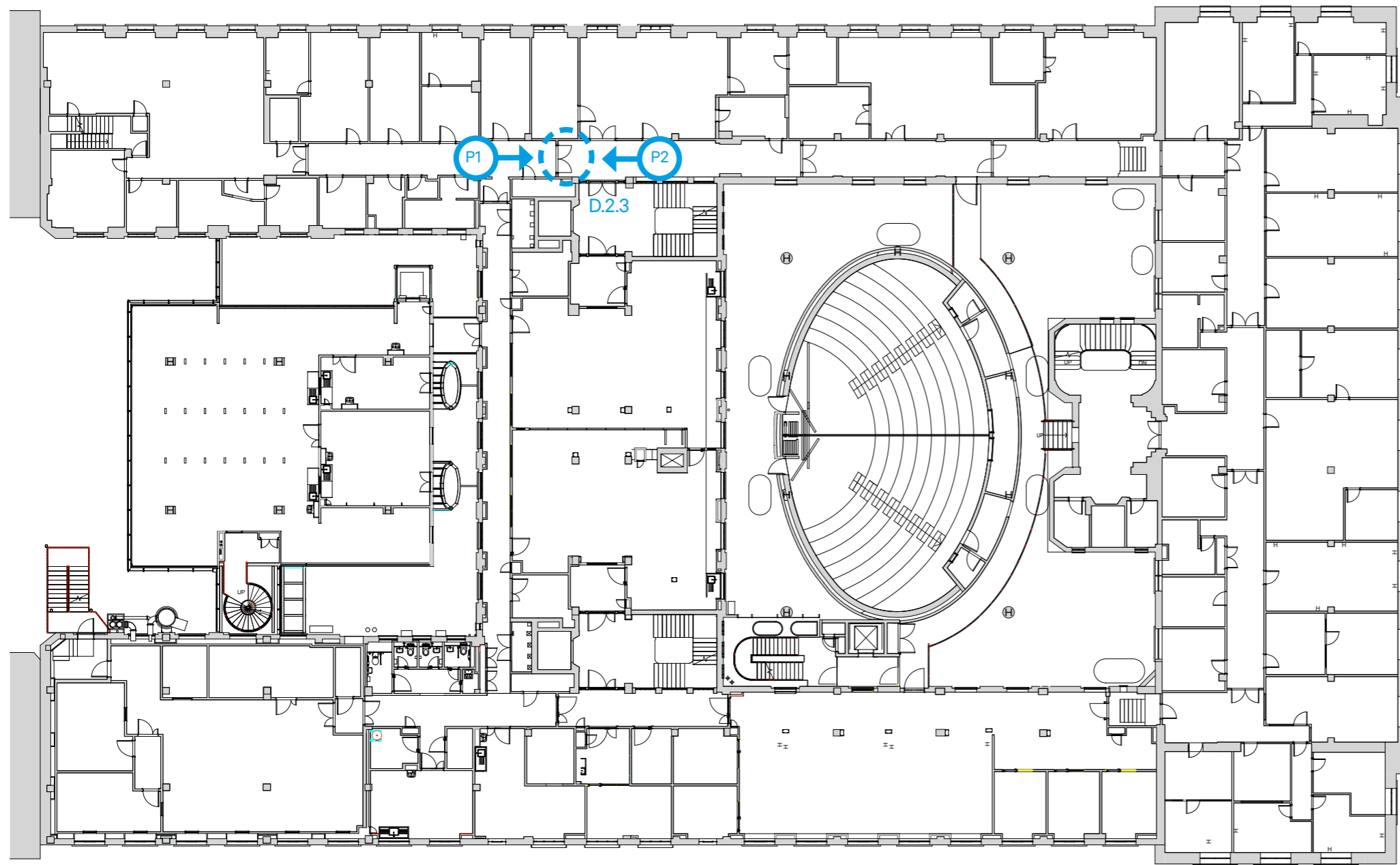

Existing Second Floor Layout

2.0 Photographic Survey

| 2.18 Second Floor Circulation Corridors



Photograph P1: Existing Door D.2.3

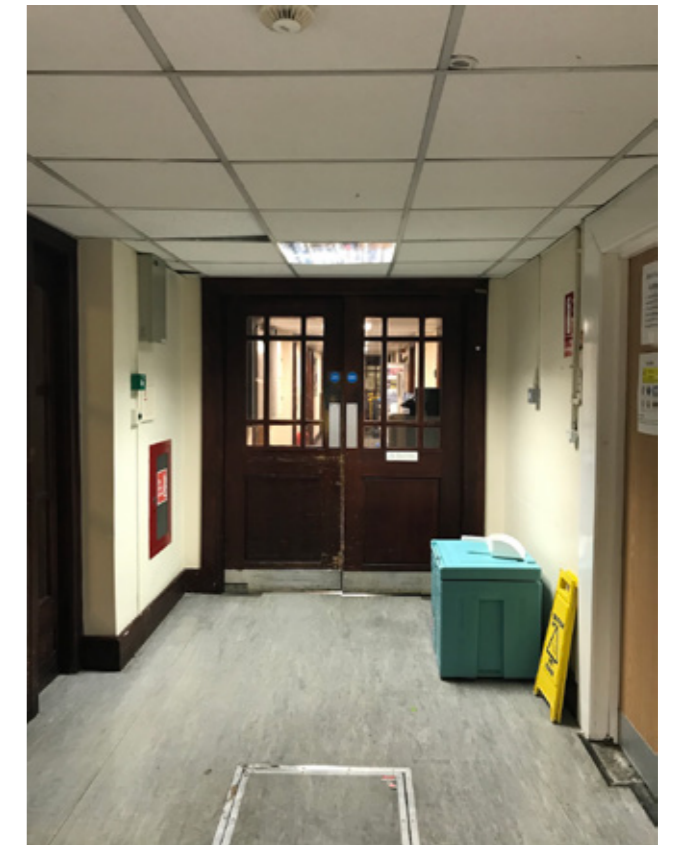

Photograph P2: Existing Door D.2.3

2.0 Photographic Survey

| 2.19 Third Floor Circulation Corridors

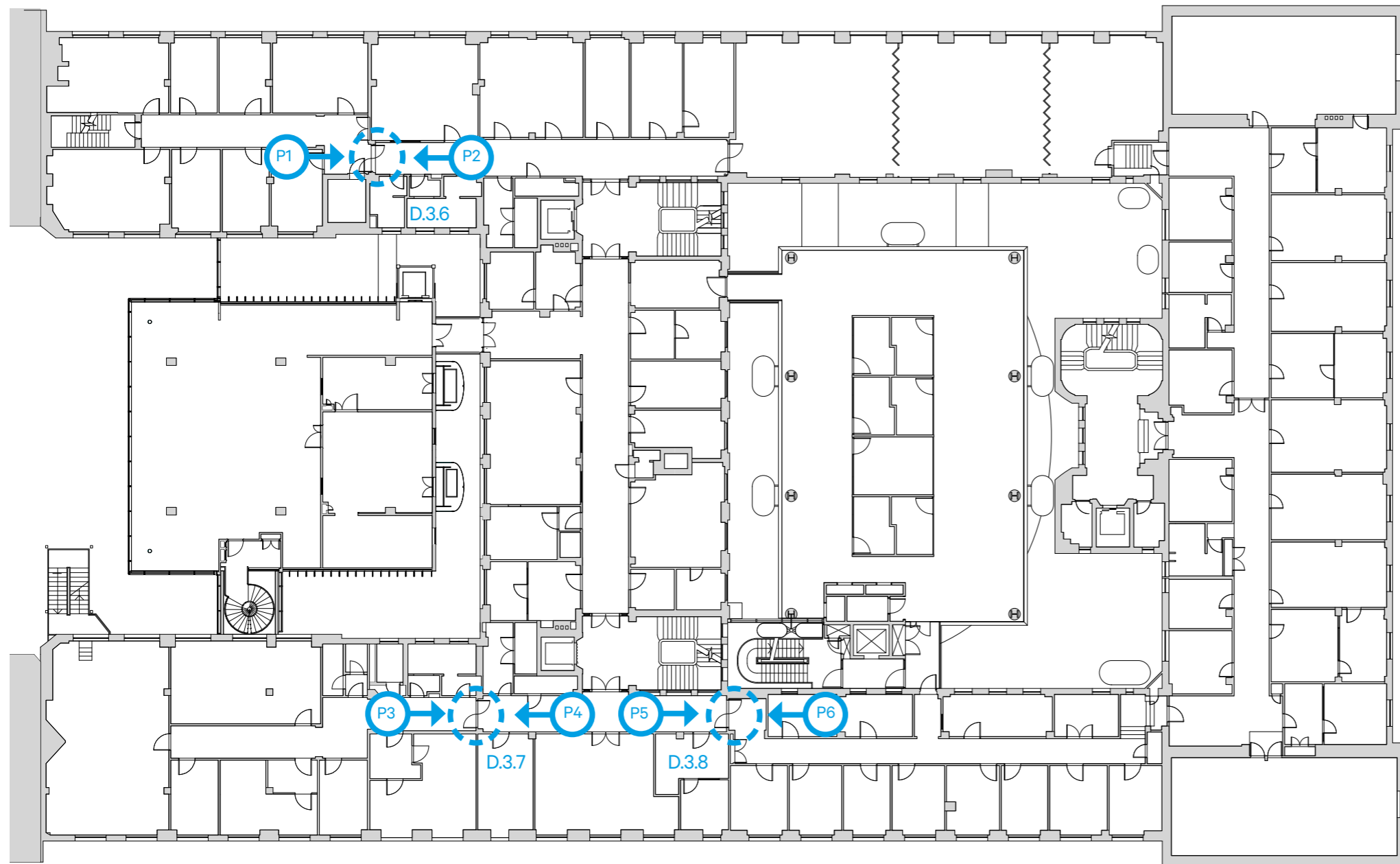

Existing Third Floor Layout

2.0 Photographic Survey

| 2.19 Third Floor Circulation Corridors



Photograph P1: Existing Door D.3.6



Photograph P2: Existing Door D.3.6

2.0 Photographic Survey

| 2.19 Third Floor Circulation Corridors



Photograph P3: Existing Door D.3.7



Photograph P4: Existing Door D.3.7



Photograph P5: Existing Door D.3.8



Photograph P6: Existing Door D.3.8

