

Written dimensions to be taken in preference to scaled dimensions. The Contractor is responsible for checking all dimensions before work starts.

All work is to be carried out to the requirements, and to the satisfaction of the Local Authority. These drawings are for planning purposes only.

Any discrepancies to be brought to the attention of 4D Planning Consultants immediately.

Description

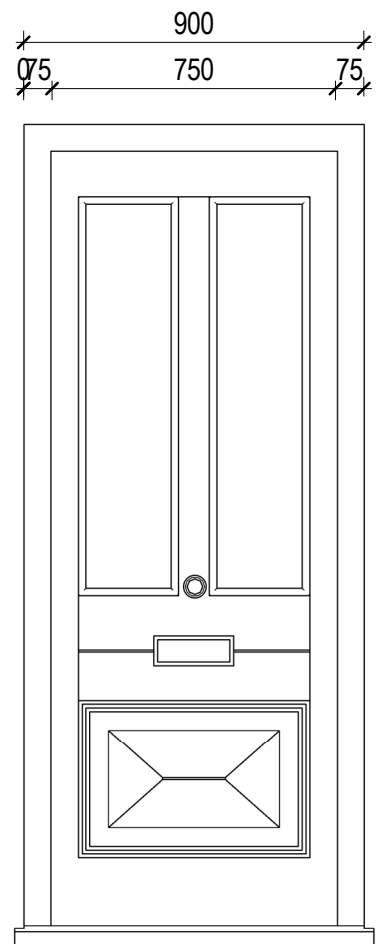
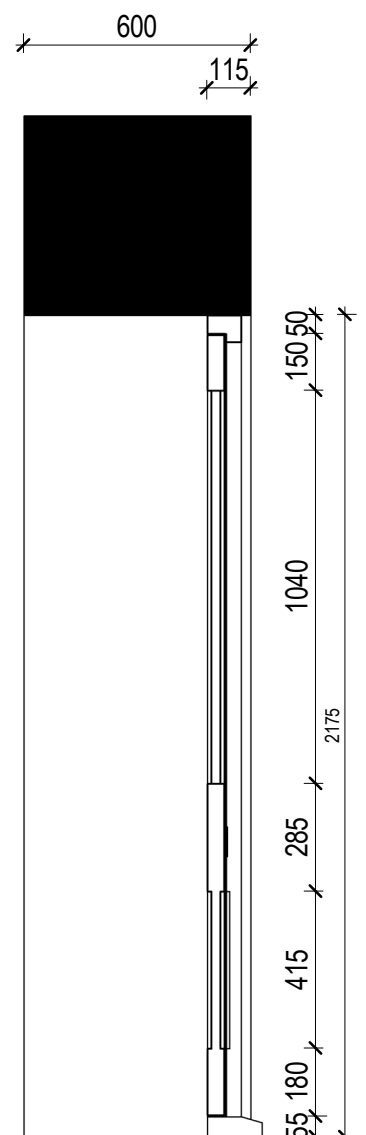
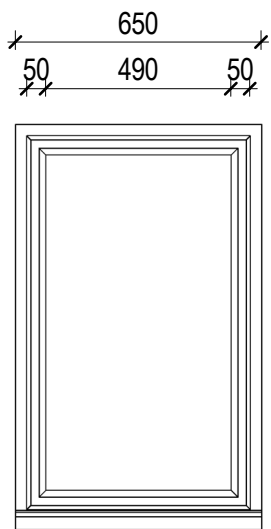
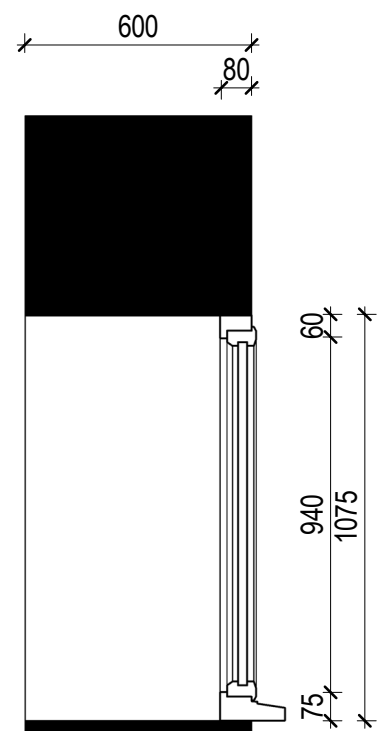

EXISTING WINDOW

1 : 20

PROPOSED DOOR

1 : 20



Rev	Date	Description	by	chk

4D PLANNING™
Chartered Town Planners & Architectural Technicians

Architecture | Town Planning

T: 0203 1500 183 www.GetMePlanning.com

www.GetMePlanning.com

Client
Jonathan and Christin Putnam

Project
Flat 2 Moreton House, Holly Walk, NW3 6RA

Title
WINDOW/ DOOR DETAIL

Date: 24.07.2023	Rev: REV B
Scale:	23.11.2023
Drawing No.4D-416 E/P 04	
Drawn by : MAX	