

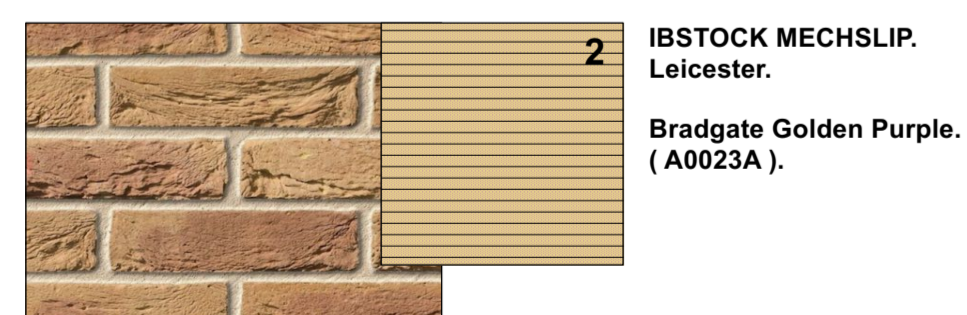

4 - NORTH WEST ELEVATION.

WALL TYPE MATERIALS AND REFERENCES :

BRICK SLIPS:



PPC ALUMINIUM PANELS: Interpon D2525.

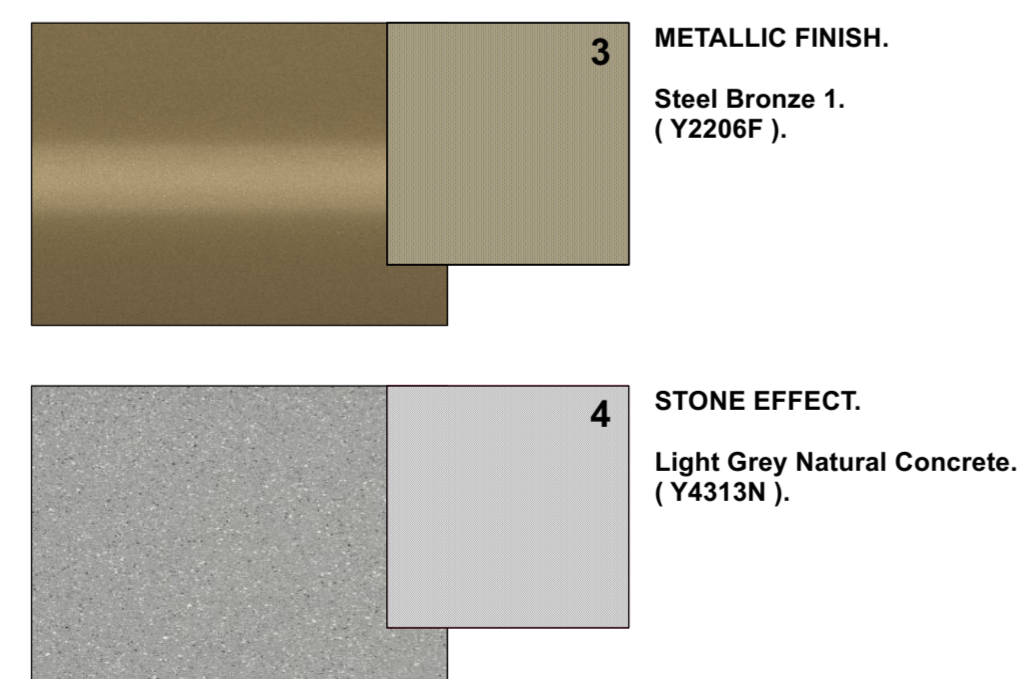

RENDER:

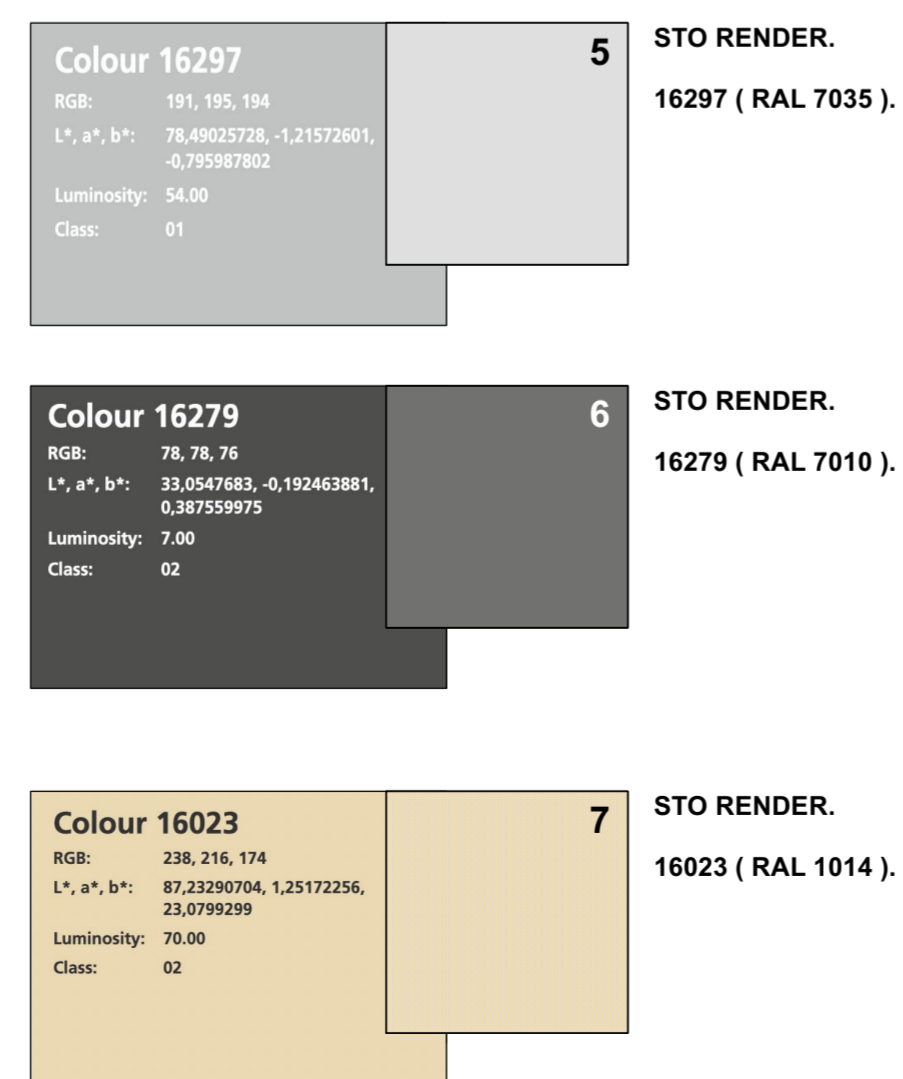

MASONRY.

A: Existing brickwork retained in place - Cavity stop sock installed at top of cavity.

BRICK SLIPS laid in Stretcher bond, with natural mortar.

2: Ibstock - Leicester - Bradgate Golden Purple - A0023A.

PPC ALUMINIUM PANELS - Interpon D2525 - Face fixed.

3: Metallic Finish - Steel Bronze 1 - Y2206F.

4: Stone Effect - Light Grey Natural Concrete - Y4313N.

STO RENDER.

5: 16297 (RAL 7035).

6: 16279 (RAL 7010).

7: 16023 (RAL 1014).

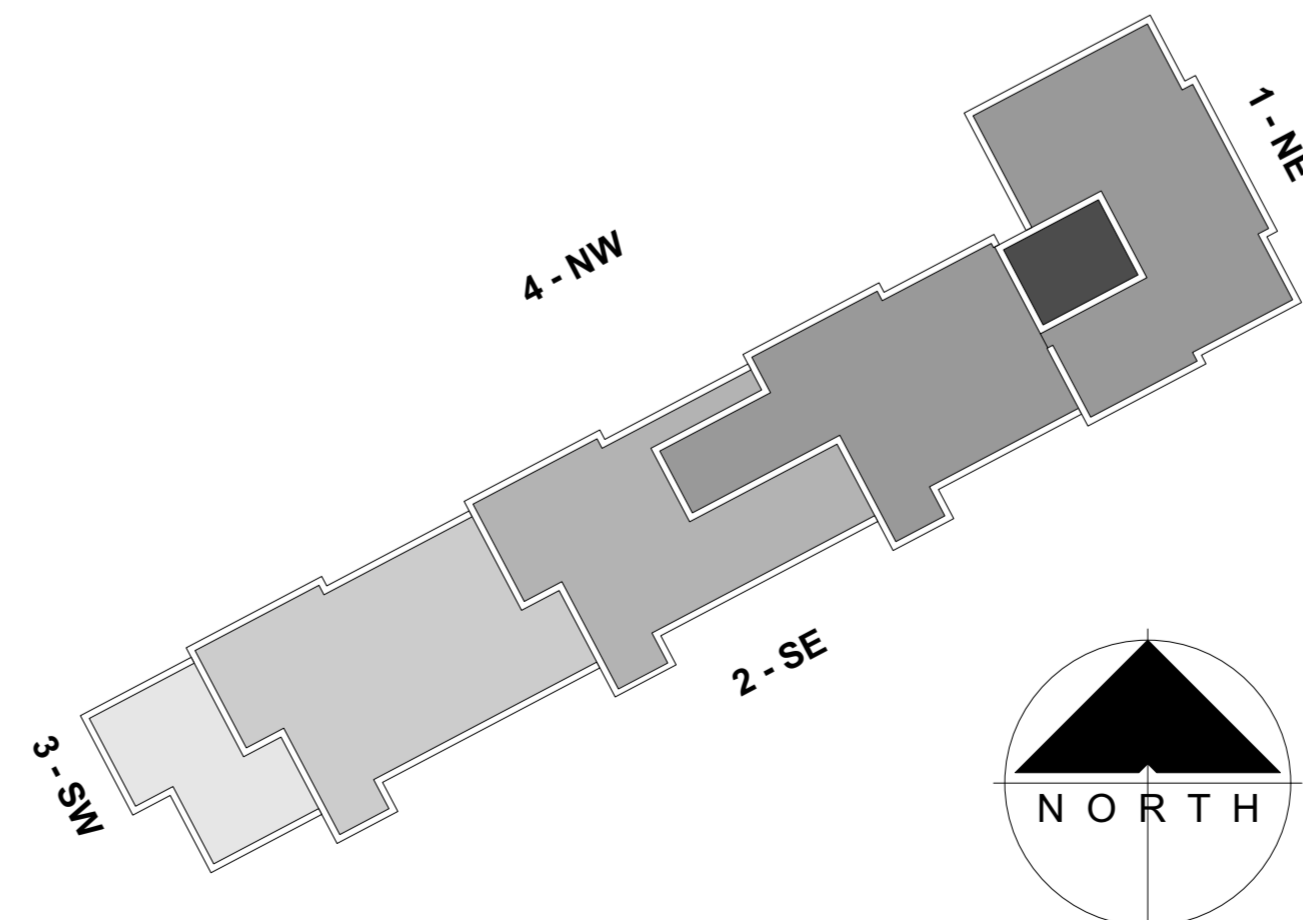

KEY PLAN.

Rev	Date	Description	By	Chk

AXIOM ARCHITECTS
 1 Brooklands Yard Southover High Street Lewes East Sussex BN7 1HU
 Tel. 01273 479434 www.axiomarchitects.co.uk

Client
M. CLARKE.

Project
 UNITE STUDENTS - BEAUMONT COURT
 1-45 COLLEGE GROVE NW
 LONDON, NW1 0RW.

Drawing
PROPOSED NORTH WEST ELEVATION.

External wall finishes.

Scale	Status	Date	Drawn	Checked
1:100 @ A1	PLANNING	21.11.23	lap	

Drawing No. **Revision**

5977-P108