



Ruby Hotel

18 Vine Hill & 15-29 Eyre
Street Hill, Clerkenwell

Waste Management Plan
prepared on behalf of Ruby
Hotels

September 2023

MILESTONE
TRANSPORT PLANNING

18 Vine Hill & 15-29 Eyre Street Hill, Clerkenwell

Project No: MTP Ref: 22-164

Document Reference No:

Document Title: Waste Management Plan

Date: September 2023

Client Name: Ruby Hotels

Project Manager: Toby Gosden

Author: Joe Holton

Produced By: [Milestone Transport Planning Limited](#)

7 Ancells Court, Rye Close, Fleet, Hampshire, GU51 2UY- Tel: 01483 397888
Gateshead IBC, Mulgrave Terrace, Gateshead, Tyne & Wear, NE8 1AN - Tel: 0191 3387220

Email: mail@milestonetp.co.uk

Web: www.milestonetp.co.uk

Document history and status

| Revision | Date | Description | Prepared By | Checked By | Authorised By |
|----------|------------|------------------------------------|-------------|------------|---------------|
| - | 12/10/2022 | First draft | J. Holton | T. Gosden | T. Gosden |
| A | 10/11/2022 | Revised to reflect client comments | J. Holton | T. Gosden | T. Gosden |
| B | 11/05/2023 | Revised to reflect LBC comments | J. Holton | T. Gosden | T. Gosden |
| C | 19/05/2023 | Revised to reflect client comments | J. Holton | T. Gosden | T. Gosden |
| D | 02/06/2023 | Revised to reflect client comments | J. Holton | T. Gosden | T. Gosden |
| E | 15/09/2023 | Revised to reflect client comments | J. Holton | T. Gosden | T. Gosden |

CONTENTS

| | | |
|----|---|----|
| 1. | Introduction | 1 |
| 2. | Commercial Waste Management | 3 |
| | Predicted Commercial Waste Generation | 3 |
| | Commercial Waste Storage Arrangements | 3 |
| | Commercial Waste Collection Arrangements | 5 |
| 3. | Residential Waste Management..... | 7 |
| | Predicted Residential Waste Generation..... | 7 |
| | Residential Waste Storage Arrangements | 7 |
| | Residential Waste Collection Arrangements | 8 |
| | Household Reuse & Recycling Centre (HRRC)..... | 9 |
| 4. | Summary & Conclusions | 10 |

Tables

| | | |
|-----------|---|---|
| Table 4.1 | Predicted Residential Waste by Type | 7 |
|-----------|---|---|

Appendices

| | |
|------------|--|
| Appendix 1 | Waste Collection Vehicle Swept Path Analysis |
|------------|--|

1. Introduction

- 1.1 This Waste Management Plan (WMP) has been prepared on behalf of Ruby Hotels (herein after referred to as the 'Applicant') in accordance with an approved planning application (Reference: 2020/0984/P) for the redevelopment of the site at 18 Vine Hill and 15-29 Eyre Street Hill, to deliver a new hotel, affordable housing units and reconfiguring existing office space.
- 1.2 Planning Condition 29 refers to the requirement to develop a waste management plan to ensure that sufficient provision for the storage and collection of waste at the site is made in accordance with Camden Local Plan policies.

"Prior to occupation of the relevant use, details of the location, design and method of waste storage and removal including recycling materials, shall be submitted to and approved by the local planning authority in writing. The facility as approved shall be provided prior to the first occupation of any of the permitted uses and permanently retained thereafter".

- 1.3 The approved description of the proposed development is as below:

"Variation of condition 2 (Approved Plans) of planning permission 2018/6016/P dated 02/01/2020 (for erection of an 8 storey building comprising a 153 bed hotel with ancillary ground floor restaurant/cafe facilities and 9 flats, excavation works to enlarge the lower ground floor level and create a lift pith, following demolition of the existing rear annex and garages at 18 Vine Hill, together with refurbishment of 18 Vine Hill and the erection of a 3 storey extension to provide additional office accommodation, landscaping and other associated works), namely alterations to the hotel to reduce height of building by 900mm, amend pre-cast concrete panels to glass reinforced concrete panels, reconfigure PV panels on roof, and revise ventilation strategy for hotel rooms on Eyre Street Hill; alterations to the office building to relocate plant to 2nd floor external terrace with installation of associated plant enclosure, alter back of house layout, increase number of WCs and form new fire escape from stair core".

- 1.4 The location of the site in the context of the local area is indicated in Figure 1.

Figure 1 Site Location

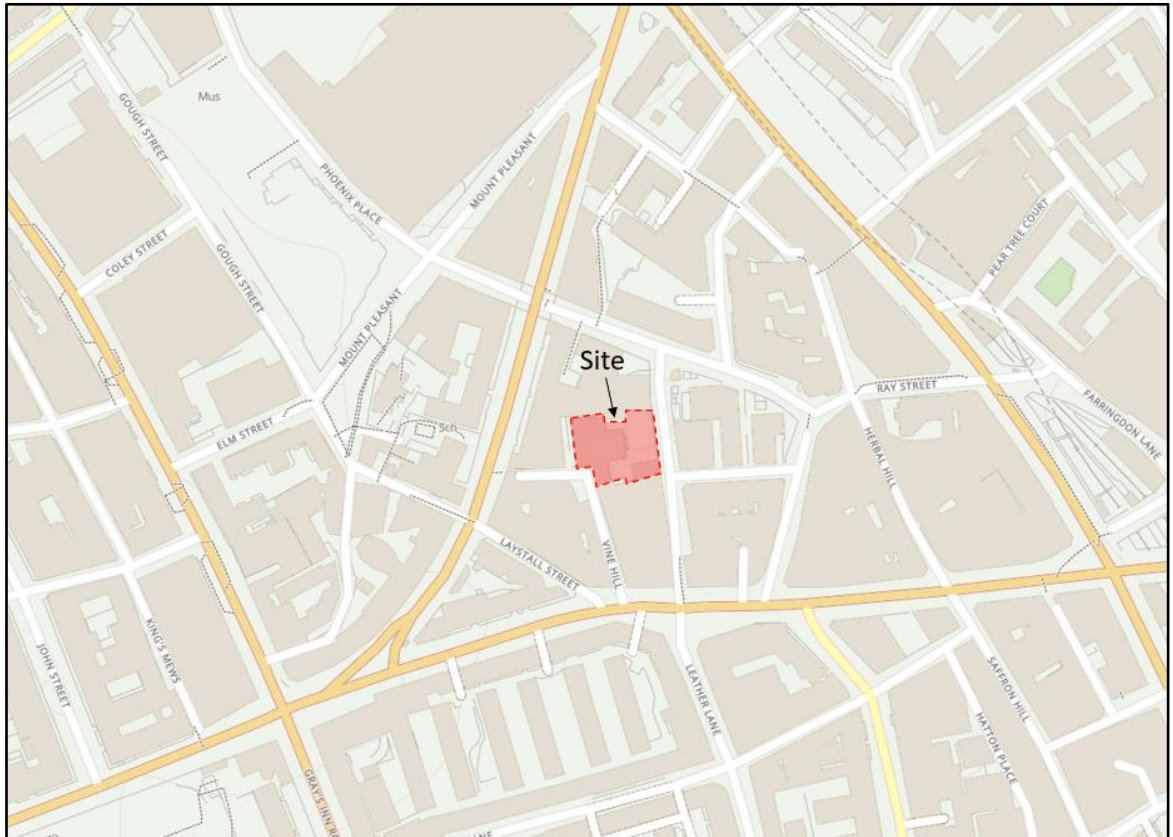

- 1.5 This WMP has been prepared to specifically consider the potential impacts that may arise from waste generated by the hotel, office and residential elements of the proposed development as well as the measures to be implemented, in accordance with policy, for the separation, storage and collection of the waste generated.
- 1.6 On this basis, the following sections of the WMP will consider:
- The strategy to be adopted by the end users for the separation, storage and collection of waste generated by the commercial development (Section 2).
 - The strategy to be adopted for the separation, storage and collection of waste generated by the residential development (Section 3).
 - Section 4 summarises and concludes the report’s findings.

2. Commercial Waste Management

Predicted Commercial Waste Generation

- 2.1 The London Borough of Camden (LBC) have agreed that in relation to the generation of waste from commercial premises, reference is made to the BS 5906:2005 "*Waste management in buildings – Code of Practice*" which suggests that for office uses, allowance should be made for 50 litres of waste per employee per week.
- 2.2 Based on the Employment Densities Guide (2015), it is assumed that the proposed development has the capacity for 1 employee per 12m², typical for a HQ, admin or 'client' facing' type occupier. Applying this to the net internal areas (NIAs) provided in para. 1.4. of the WMP, the following waste generation per week is calculated for the office floorspace within the proposed development:
- Renovated office space (2,832sqm) - capacity for up to 236 employees = 11,800l waste per week
- 2.3 Additionally, the proposed development involves 153 hotel rooms. When evaluating the "*Waste management in buildings – Code of Practice*", and assessing a comparable hotel in the area, a typical hotel room generates 150l of waste per week. With this information, a calculation can be completed as follows:
- Renovated hotel space (153 rooms) x 150l = 22,950l waste per week
- 2.4 When combining the predicted waste generated by the existing office space and the proposed hotel, the total commercial waste generated per week by the development is 34,750l.

Commercial Waste Storage Arrangements

- 2.5 It is assumed that the mix of storage between landfill waste and recycling will be 50:50 reflecting the fact that office-type accommodation generally has a higher propensity to generate recyclable items such as paper that can be reclaimed. In comparison, waste produced by the proposed micro-hotel is more likely to comprise of landfill waste than recyclable waste.
- 2.6 It should be noted that confidential paper waste will be shredded and placed with regular mixed recycling.
- 2.7 Should there be any hazardous waste or waste that required additional control or servicing measures, this will be safely stored in the refuse area and disposed of according to Camden Council Hazardous Waste guidelines.
- 2.8 Should there be any bulky waste in the form of broken furniture or items surplus to requirements, it is anticipated these will be stored in hotels rooms not in use and disposed of or repurposed at an appropriate time and manner.
- 2.9 Given the scale of development, potential employee capacity and waste generated, the most efficient storage solution is the use of 1,100l capacity containers (also known as '*Eurobins*'), as per the specification illustrated in Figure 2.

2.10 The number of containers required to accommodate the waste generation of the development will be dependant upon the frequency of collections. For a development of this scale it is proposed that waste collection will be undertaken on a daily basis (5 days per week). On the basis of daily collections, the number of 1,100l capacity containers required for each part of the commercial development is outlined below:

- Office = 6 x 1,100l containers
- Hotel = 6 x 1,100l containers

Figure 2 Typical Commercial Waste Storage Container

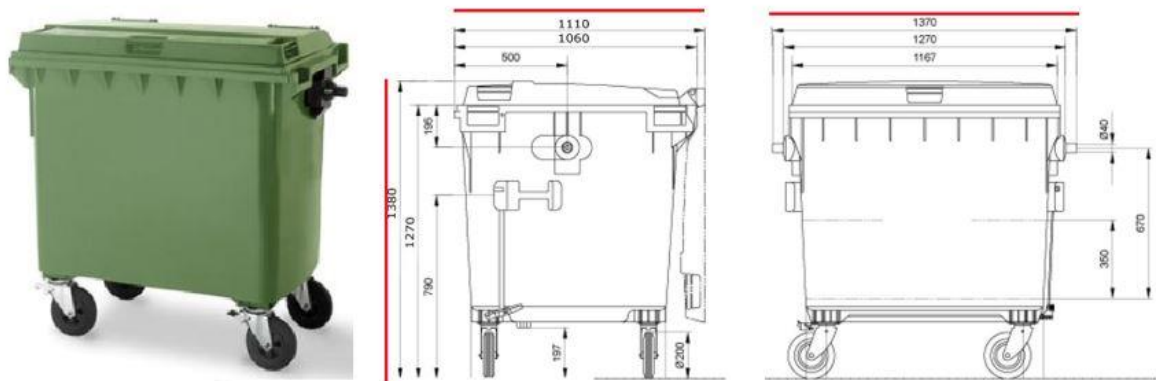

2.11 All bins are to be stored in a designated service area to the northern boundary of the site, located at street level. Access to this service area can be found via a gated entrance on the western side of Eyre Street Hill. Containers will be separated into distinguished areas for the hotel and the office space, and colours of waste storage containers will indicate the type of waste being stored (General waste, Recycling and Organic/Food waste).

2.12 The location of the service area in relation to the rest of the ground floor can be seen to the north of the site plan in Figure 3.

Figure 3 Proposed Waste Storage Arrangements



Commercial Waste Collection Arrangements

- 2.13 All waste for both commercial operations within the proposed development will be collected from the designated service area to the north of the site, accessed off the western side of Eyre Street Hill. A dropped kerb is provided from the gate to the roadway. Refuse collection operators will be provided with fob access to the refuse store within the building.

- 2.14 All refuse vehicles will be carrying out the collection of waste on-street and will not be entering the site with the refuse vehicle. Given the nature of the road being one-way and of significant width, it has been deemed appropriate for a refuse vehicle to stop in the carriageway for a short time in order to remove waste stored on the site. It should be noted that the refuse vehicle will not be required to reverse. Waste collection operatives will be informed by the Building Management team of the pre-defined access / egress routing to / from the site, as illustrated in Figure 4.

Figure 4 Commercial Waste Collection Pre-Defined Access / Egress Routes



- 2.15 Access to the servicing area will be through a gated access point on Eyre Street Hill. This will either be opened by staff from the building, or an access agreement can be made with more regular users of the servicing area, such as daily refuse collectors.
- 2.16 Upon entry, refuse vehicle staff and operators would collect the waste containers and move them out of the service area, onto the street where the waiting refuse vehicle can empty them. Staff from the building management team would be required to assist with this due to the waste storage containers being located more than 10metres from the designated collection point.
- 2.17 As noted previously within this section of the WMP, it is anticipated that daily waste collections would be required based upon the volume of waste generated and the number of waste containers provided. Dwell time for waste collection vehicles on the site is expected to be no more than 15 minutes on any given day.

3. Residential Waste Management

Predicted Residential Waste Generation

3.1 With reference to the Technical Waste Planning Guidance adopted by LBC, the weekly generation of waste from the residential element of the proposed development is calculated based on no. units x 120L general waste, no. units x 140L mixed recycling and no. units x 23L food waste. On this basis, Table 4.1 summarises the anticipated weekly waste generation from the residential element of the proposed development per week, broken down by type.

Table 4.1 Predicted Residential Waste by Type

| Waste Type | Volume |
|-----------------|--------|
| Landfill | 873l |
| Mixed Recycling | 1260l |
| Food | 207l |

3.2 It should be noted that the 207L of food waste is deductible from the total general waste produced, therefore producing 873L as opposed to the value of 1,080L.

Residential Waste Storage Arrangements

3.3 At present, flatted properties in Camden generally have waste collected weekly. However, existing collections on Eyre Street Hill are carried out daily. Based on this, the proposed residential units will be provided with three storage solutions for waste types, the details of which are provided below and illustrated in Figure 5. Collections will occur twice weekly.

- Landfill Waste - 660l wheeled container
- Mixed Recycling - 660l wheeled container
- Food - 660l wheeled container

3.4 LBC collect food waste on a weekly basis. Landfill waste and DMR / P&C are collected on an alternate weekly basis.

Figure 5 Typical Residential Waste Storage Containers



- 3.5 As noted previously, the containers are distinguished by the use of different colours and each zone for storage will be clearly signed.
- 3.6 The residential building waste storage area can be found in the service yard, opposite to the waste storage containers used by the 153 room hotel. These waste storage containers are located within 10metres of the designated access point.
- 3.7 The residential building waste storage area is within the vicinity of a lift that services the residential units, providing step-free access to the waste storage area for all users and residential units.

Residential Waste Collection Arrangements

- 3.8 Similarly to commercial waste on the site, the access door to the service area is located on the western side of Eyre Street Hill. The waste collection vehicle will load from Eyre Street Hill, utilising the full carriageway width to allow other road users to pass whilst stationary. The vehicle will remain on Eyre Street Hill and will not be entering the site at any point. A dropped kerb is provided from the gate to the roadway. Refuse collection operators will be provided with fob access to the refuse store within the building.
- 3.9 Swept path analysis of a refuse collection vehicle (10.12m (l) x 2.25m (w)), the largest vehicle anticipated to service the residential building, entering and exiting Eyre Street Hill, is included as Appendix 1 to the WMP.
- 3.10 It is anticipated that weekly waste collections would be required based upon the volume of waste generated by the residential units, the number of waste containers provided and the existing practices of other residential units on Eyre Street Hill. Dwell time for waste collection vehicles on the site is expected to be no more than 15 minutes, once a week on collection day.
- 3.11 Figure 6 illustrates the pre-defined access / egress routes for residential waste collection at the site.

Figure 6 Residential Waste Collection Pre-Defined Access / Egress Routes

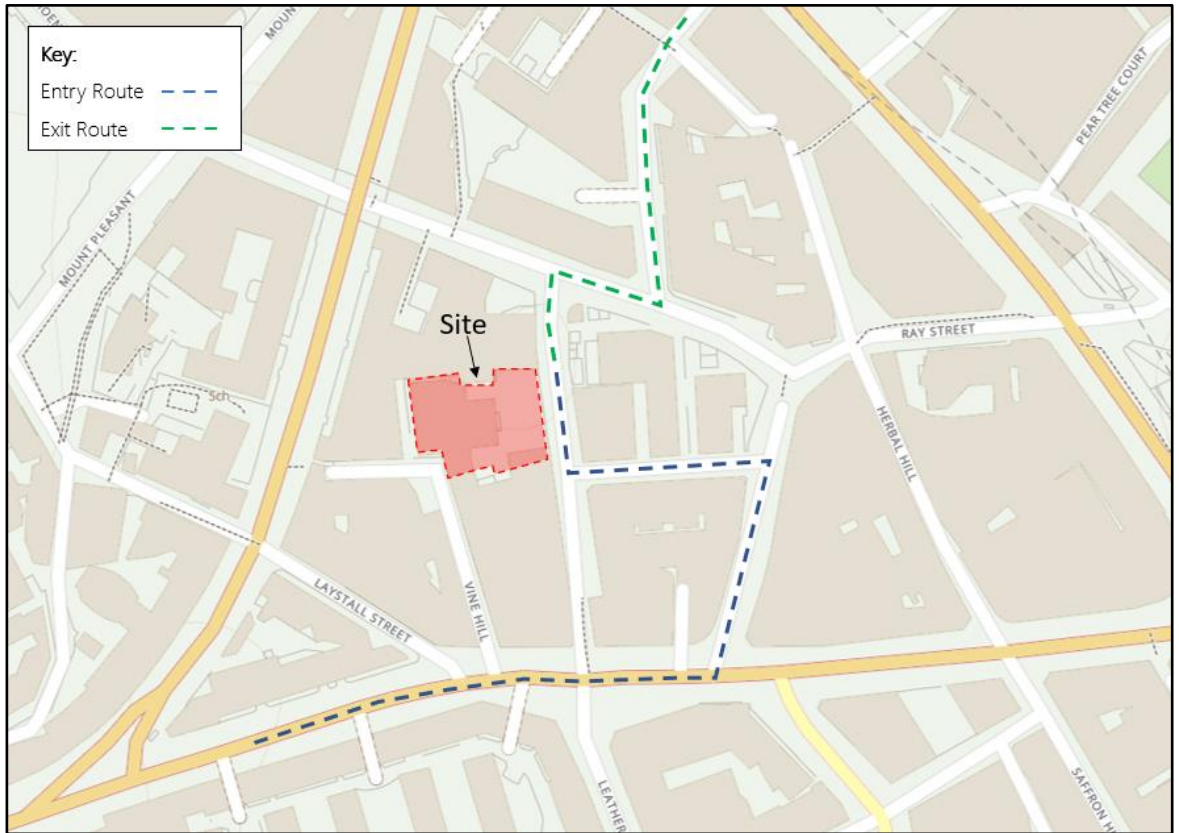

Household Reuse & Recycling Centre (HRRC)

- 3.12 The publicly accessible Regis Road Household Reuse & Recycling Centre (HRRC) is provided by LBC and is located 4.8km North-West of the development site.
- 3.13 Access to the Regis Road can be booked on the day, and up to two weeks in advance if travelling by car, bike or as a pedestrian.
- 3.14 Alternatively, the Affordable Housing Provider Estates team will also be on hand to arrange spot collection of bulky items as and when necessary.

4. Summary & Conclusions

- 4.1 This Waste Management Plan (WMP) has been prepared on behalf of Ruby Hotels in accordance with an approved planning application (Reference: 2018/6016/P) for the redevelopment of the site at 18 Vine Hill and 15-29 Eyre Street Hill, to deliver a new hotel, affordable housing units and reconfiguring existing office space.
- 4.2 The WMP has considered the potential impacts that may arise from waste generated by both the commercial and residential elements of the proposed development as well as the measures to be implemented, in accordance with national, London and LBC policy, for the separation, storage and collection of the waste generated.
- 4.3 From the results of the WMP the following can be concluded:
- The commercial office floorspace has the potential to generate up to 11,800l of waste storage generation over a typical working week, equivalent to 2,360l per day based on a 5-day week;
 - Hotel operations of the 153 rooms has the potential to generate up to 22,950l of waste per week, equivalent to 3,279l per day;
 - Both landfill waste and recycling waste will be stored in separate 1,100l wheeled storage containers (or 'Eurobins') that generates a total requirement for a minimum of 12 wheeled storage containers (6 for office use, 6 for hotel use);
 - All waste for both the office space and hotel space of the development will be collected from the on-street delivery / collection zone outside of the site on Eyre Street Hill;
 - Waste generated from the office space will be wheeled across the service area by the Building Management team in advance of the pre-determined daily collection time;
 - Commercial waste collection will occur on a daily basis (5 days per week) and based on the volume of waste and number of containers provided, it is anticipated that the waste collection vehicle will be on-site for no more than 15 minutes per day;
 - The service yard is designed to accommodate all waste containers required by the site. The waste collection vehicle will not enter the site at any time, but will use the carriageway when loading;
 - Waste collection operatives will be informed by the Building Management team of the pre-defined access and egress routes in advance;
 - The residential element of the development proposals is predicted to generate a total of 2,340l of waste over a weekly period split into landfill waste, mixed recycling and food waste, based on the size of unit and number of bedrooms proposed;
 - By the volume of waste generated by type, the residential development requires the provision of 3 x 660L storage containers for landfill waste, recycling and food waste;
 - The residential development will be provided with step-free access to the waste storage area in the service yard through the use of a lift, servicing all residential units;
 - An external door from the waste storage area in the service yard will lead, via a level access to Eyre Street Hill, which is designed to accommodate the swept path and loadings of a waste collection vehicle;

- The waste collection vehicle will load from the Eyre Street Hill carriageway in its widest section to enable other road users to pass whilst stationary;
- Waste collection for the residential element of the development proposals will be collected on a twice weekly basis for all waste, landfill, mixed recycling and food waste;
- Based on the volume of waste and number of containers provided, it is anticipated that the waste collection vehicle will be on-site for no more than 15 minutes;
- Waste collection operatives will be informed by the Building Management team of the pre-defined access and egress routes in prior to waste collection;
- Refuse collection operators will be provided with fob access to the refuse store within the building;
- Residents are able to access the Regis Road Household Reuse and Recycling Centre (HRRC) to dispose of additional waste, albeit with certain restrictions imposed on what can / cannot be disposed of at the facility. The Regis Road HRRC is 4.8kms from the site.
- The Estates team will also arrange spot collection of bulky items for residents if necessary.

Appendix 1

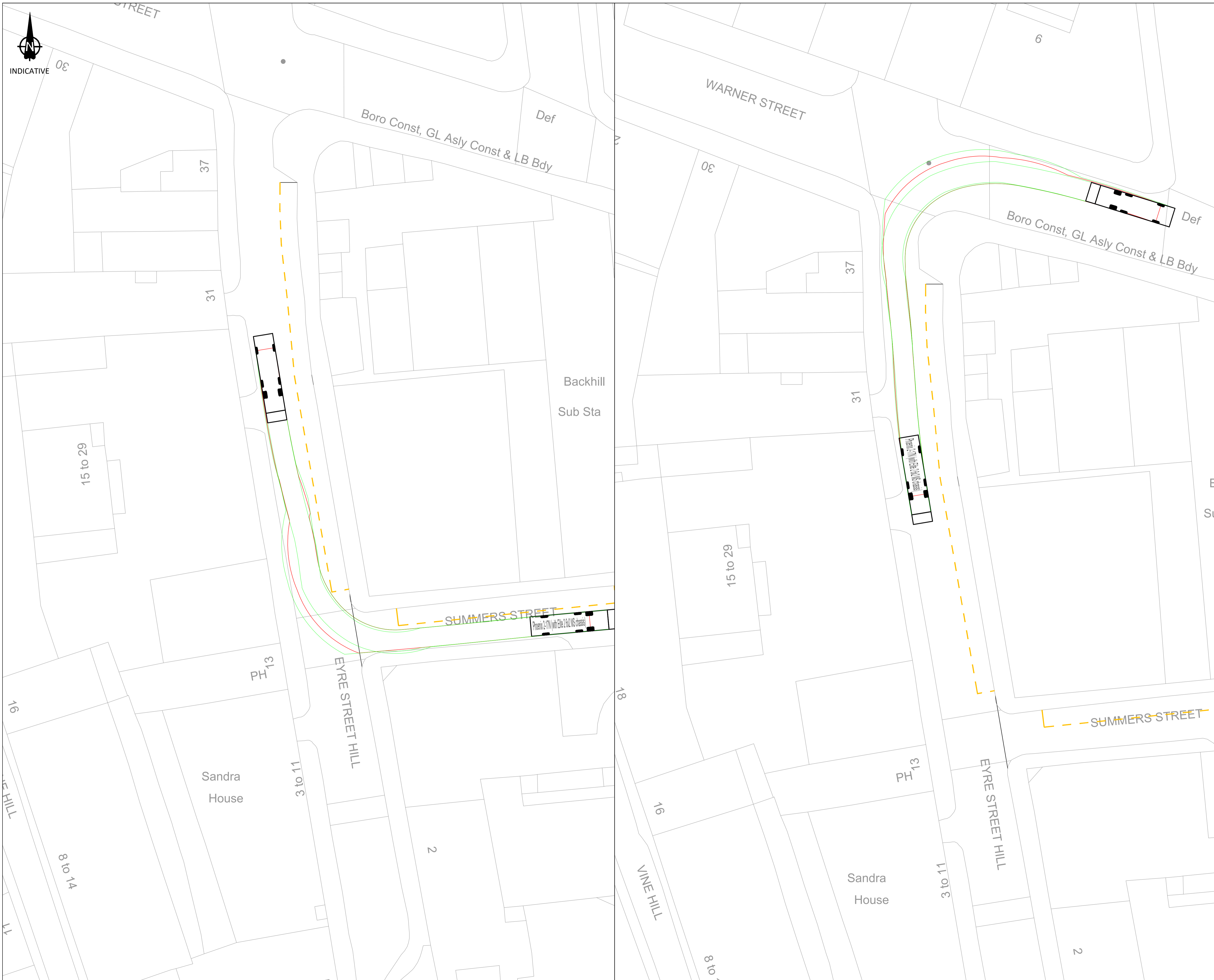

- Notes**
1. Do not scale from this drawing. All dimensions shown are in metres unless noted otherwise.
 2. This drawing has been based upon Ordnance survey information produced by others and Milestone Transport Planning cannot be held responsible for any discrepancies which may arise because of it.

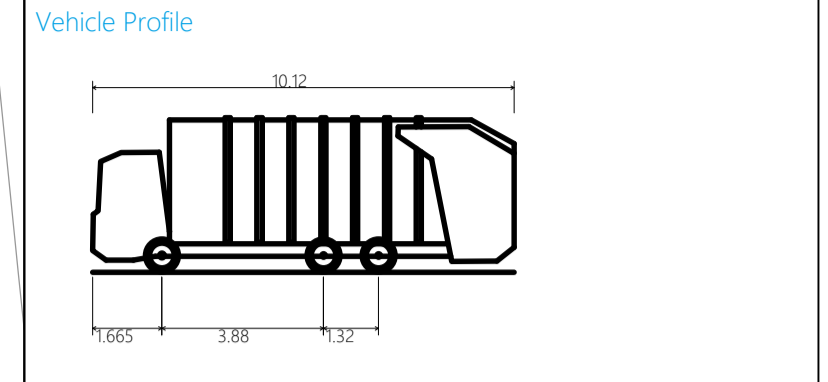

Phoenix 2-17N (with Elite 2 6x2 MS chassis)

| | |
|-----------------------------|---------|
| Overall Length | 10.120m |
| Overall Width | 2.250m |
| Overall Body Height | 3.707m |
| Min Body Ground Clearance | 0.250m |
| Track Width | 2.250m |
| Lock to lock time | 4.00s |
| Kerb to Kerb Turning Radius | 11.550m |

Ordnance Survey Licence number: 100057360

Drawing Revisions

| Rev: | Drn: | Date: | Details: | Chk: |
|------|------|------------|-------------|------|
| - | JH | 14/10/2022 | First issue | TG |

Client
Ruby Hotels

Project
Ruby Hotel, Vine Hill / Eyre Street Hill

Title
Swept Path Analysis of Refuse Vehicle

MILESTONE
TRANSPORT PLANNING

Abbey House, 282 Farnborough Rd, Farnborough, Hants GU14 7NA
Tel: 01483 397888
Gateshead IBC, Mulgrave Terrace, Gateshead, NE8 1AN
Tel: 0191 338 7220
web: www.milestonetp.co.uk

Drawing Number: 22164-TK01
Scale: 1:200 @ A1
Revision: