



Mona Relief

A robust irrigation unit that delivers water straight to the roots of the tree. Installed with a perforated pipe that surrounds the tree's rootball, the Mona Relief system is a cost effective solution for preventing drought with newly planted tree. Available with optional Aria Vented Inlet - allows water to be filled through the cap whilst preventing debris from blocking the pipe.

Features

- 35mm irrigation pipe
- Quick and simple to install
- Discreet and unobstructive

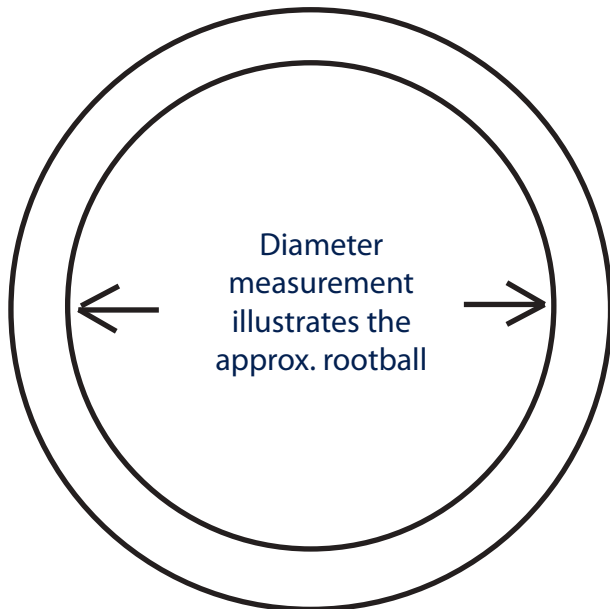

Model	Diameter of Irrigation Ring	Application Type
MR1	400mm	Small trees and specimen shrubs
MR2	560mm	Standard and select standard trees, check rootball diameter to match your irrigation kit
MR3	800mm	Standard and select standard trees, check rootball diameter to match your irrigation kit
MR4	1300mm	Standard and select standard trees, check rootball diameter to match your irrigation kit

Green-tech endeavour to ensure that the information given on this technical data sheet is accurate, but accept no liability for its use or its suitability for particular application.

Rabbit Hill Business Park, Great North Road, Arkendale, Knaresborough HG5 0FF

T: 01423 332100 E: sales@green-tech.co.uk W: www.green-tech.co.uk Facebook: @greentechuk Twitter: @greentechltd

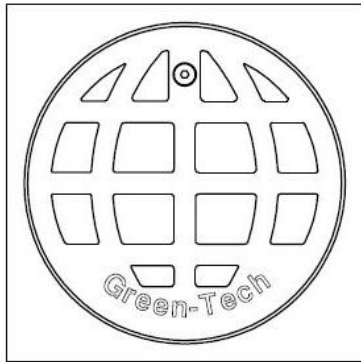

PLAN

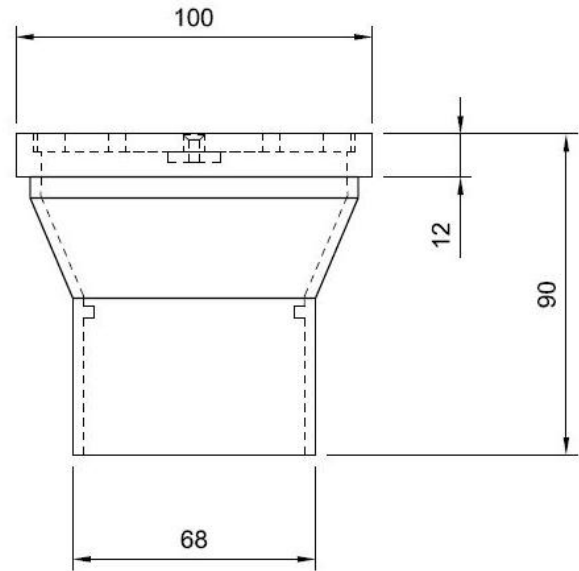

ELEVATION

Application

1. Place tree root ball in hole as with normal planting instructions.
2. Measure the circumference of the root ball and cut the Mona Relief pipe to the required size. Connect both ends of the pipe to the Mona Relief T junction. The Mona Relief is most efficient when positioned within the top third of the rootball.
3. Insert the Mona Relief feeding pipe with cap into the T junction.
4. Back fill the area covering the Mona Relief ring and feeding pipe evenly, ensuring it remains level at all times.
5. Leave space for the cap and feeding pipe to protrude from the ground, this prevents blockages of soil, stones and mulches.

Specification

It is recommended that when an urban tree is planted a tree irrigation system is put in place to ensure the tree receives the best start. By proactively installing a system that will irrigate at the root ball, the tree's roots instantly receive the much needed water to aid growth.

All Mona Relief inlets are available with varying irrigation pipe sizes, dependant on the root ball size.